

There's always a solution in steel.

AISC Live Webinars

Thank you for joining our live webinar today.
We will begin shortly. Please stand by.

Thank you.

Need Help?

Call ReadyTalk Support: 800.843.9166



AISC Live Webinars

Today's audio will be broadcast through the internet.

Alternatively, to hear the audio through the phone, dial:

(888) 632-5004

Passcode: 542543



AISC Live Webinars

Today's live webinar will begin shortly. Please stand by.

As a reminder, all lines have been muted. Please type any questions or comments through the Chat feature on the left portion of your screen.

Today's audio will be broadcast through the internet.
Alternatively, to hear the audio through the phone, dial:

(888) 632-5004

Passcode: 542543



AISC Live Webinars

AISC is a Registered Provider with The American Institute of Architects Continuing Education Systems (AIA/CES). Credit(s) earned on completion of this program will be reported to AIA/CES for AIA members. Certificates of Completion for both AIA members and non-AIA members are available upon request.

This program is registered with AIA/CES for continuing professional education. As such, it does not include content that may be deemed or construed to be an approval or endorsement by the AIA of any material of construction or any method or manner of handling, using, distributing, or dealing in any material or product.

Questions related to specific materials, methods, and services will be addressed at the conclusion of this presentation.



AISC Live Webinars

Copyright Materials

This presentation is protected by US and International Copyright laws. Reproduction, distribution, display and use of the presentation without written permission of AISC is prohibited.

© The American Institute of Steel Construction 2017

The information presented herein is based on recognized engineering principles and is for general information only. While it is believed to be accurate, this information should not be applied to any specific application without competent professional examination and verification by a licensed professional engineer. Anyone making use of this information assumes all liability arising from such use.



Course Description

Top 10 Changes in the 8th Edition AASHTO LRFD Steel Specifications December 13, 2017

This webinar will present and explain the background of the Top 10 most significant changes to the steel specifications that appear in the new 8th Edition AASHTO LRFD Bridge Design Specification and will review the anticipated effect of each of these changes.

Changes include:

- Simplified bolted splice design
- Skewed and curved I-girder bridge fit and framing arrangements
- Recommended details to avoid constraint-induced fatigue
- Revisions to bolt resistance calculations
- And more!



Learning Objectives

- Identify 10 of the most significant steel-specification changes to appear in the new AASHTO 8th Edition LRFD Bridge Design Specification.
- Identify the intent of the specification changes
- Identify the anticipated effect of the specification changes
- Locate additional resources that aid in steel bridge design



There's always a solution in steel.

Top 10 Changes in the 8th Edition AASHTO LRFD Steel Specifications



Presented by
Michael A. Grubb, P.E.
M.A. Grubb & Associates, LLC
Wexford, Pennsylvania



AASHTO T-14 Technical Committee for Structural Steel Design

2016 AASHTO SCOBS Meeting – Minneapolis, MN



23 T-14 Agenda Items balloted and approved

Revisions appear in the 8th Edition *LRFD Bridge Design Specifications* (November 2017)



10. Increase in Maximum Shear Connector Spacing

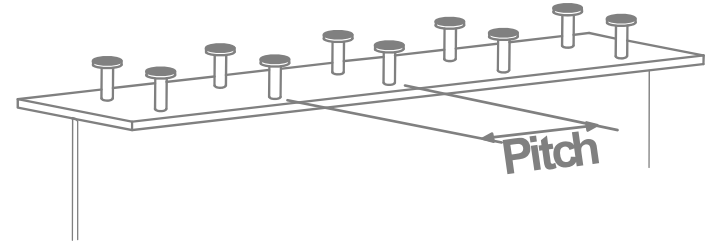

Description of Specification Revisions:

- Increased maximum shear connector spacing (pitch) from 24.0 inches to 48.0 inches. However, only for web depths > 24.0 inches.
- Added more descriptive commentary related to the old and new limits, and added three new references to Article 6.17.

Anticipated Effect:

- Nothing to the detriment in terms of design. For ABC, precast deck panel construction should be less burdensome, and interferences in the field should be reduced.



9. Global Displacement Amplification of Narrow I-Girder Systems

Description of Specification Revisions:

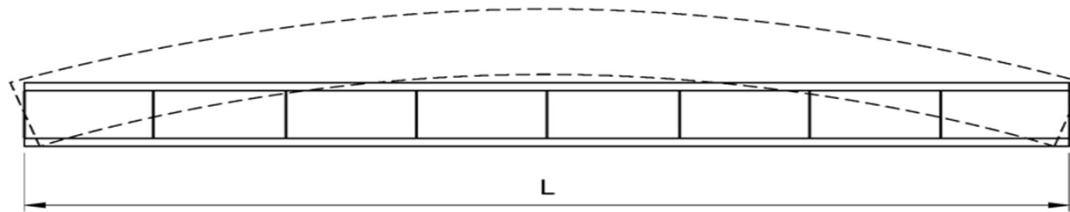

- Eigenvalue buckling & large displacement analyses were recently conducted at the University of Texas.
- Eq. 6.10.3.4.2-1 is revised to include a system moment-gradient modifier, C_{bs} , as follows:

$$M_{gs} = C_{bs} \frac{\pi^2 w_g E}{L^2} \sqrt{I_{eff} I_x}$$

$$C_{bs} = \begin{aligned} &= 1.1 \text{ for simply-supported units} \\ &= 2.0 \text{ for continuous-span units} \end{aligned}$$



9. Global Displacement Amplification of Narrow I-Girder Systems

- Compare the buckling capacity, M_{gs} , with the sum of the largest total factored girder moments within the span (rather than the sum of the largest total factored *positive* girder moments).
- The limit on the sum of the largest moments within the span is raised from 50% to 70% of M_{gs} .
- Narrow *curved* I-girder units should be analyzed using a global second-order load-deflection analysis. Alternatively, add lateral bracing adjacent to supports of the span, or brace unit to other units or with external bracing (Article C6.10.3.4.2).

Anticipated Effect:

- Larger elastic global lateral-torsional buckling resistances should result for narrow straight 2- and 3-girder systems in their noncomposite condition during the deck placement.



8. Introduction of the Unified Effective Width Approach

Description of Specification Revisions:

- Introduces the unified effective width approach for the calculation of the nominal compressive resistance of members with slender element cross-sections (Articles 6.9.4.1 & 6.9.4.2).
 - Adopted in the 2016 AISC Specification and the 2016 AISI *North American Specification for the Design of Cold-Formed Steel Structural Members*.
 - Accounts for the effect of potential local buckling of slender elements, supported along one or two longitudinal edges, on the overall column-buckling resistance of the member.

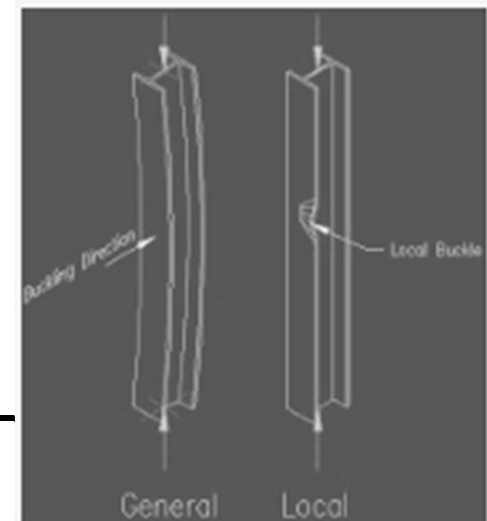

13



8. Introduction of the Unified Effective Width Approach

- Replaces the previous Q-factor approach to handle compression members with slender elements – originally adopted in the 1969 AISC and AISI Specifications.
- Table 6.9.4.2.1-1 is revised to replace the “plate-buckling coefficients”, k , with corresponding width-to-thickness ratio limits, λ_r .

6.9.4.2.1-1—Plate Buckling Coefficients and Width of Plates for Axial Compression Element Width-to-Thickness Ratio Limits and Element Widths for Axial Compression

Plates Supported along One Longitudinal Edge (Unstiffened Elements)	λ_r	b
Flanges of Rolled I-, Tee, and Channel Sections; Plates Projecting from Rolled I-Sections; and Outstanding Legs of Double Angles in Continuous Contact	0.56	<ul style="list-style-type: none"> • Half-flange width of rolled I- and tee sections
	$0.56 \sqrt{\frac{E}{F_y}}$	<ul style="list-style-type: none"> • Full-flange width of channel sections • Distance between free edge and first line of bolts or welds in plates

- Reference to the terms “unstiffened elements” and “stiffened elements” is removed in the specification and commentary.



8. Introduction of the Unified Effective Width Approach

- The nominal compressive resistance, P_n , is obtained by multiplying F_{cr} based on the gross cross-sectional area by an effective area, A_{eff} .
- A_{eff} is generally computed as the summation of effective areas of the cross-section based on reduced effective widths, b_e , for each slender element in the cross-section (Article 6.9.4.2.2a).

$$b_e = b \left(1 - c_1 \sqrt{\frac{F_{el}}{F_{cr}}} \right) \sqrt{\frac{F_{el}}{F_{cr}}} \quad (6.9.4.2.2a-2)$$

in which:

c_1 = effective width imperfection adjustment factor determined from Table 6.9.4.2.2a-1

c_2 = effective width imperfection adjustment factor determined from Table 6.9.4.2.2a-1
 $= \frac{(1 - \sqrt{1 - 4c_1}) / (2c_1)}{}$ (6.9.4.2.2a-3)

F_{el} = elastic local buckling stress (ksi)

$$= \left(c_2 \frac{\lambda_y}{(b/t)} \right)^2 F_y \quad (6.9.4.2.2a-4)$$

- For circular tubes and round HSS, A_{eff} is computed directly from equations (Article 6.9.4.2.2b).



8. Introduction of the Unified Effective Width Approach

Anticipated Effect:

- More streamlined approach that applies to slender plate elements supported along one or two longitudinal edges.
- Assists with the future implementation of new LRFD Design Specifications for noncomposite steel box sections under development.



7. Recommended Details to Avoid Conditions Susceptible to Constraint-Induced Fracture

Description of Specification Revisions:

- New definitions are added to Article 6.2 for a:
 - ‘Transverse Connection Plate’
 - ‘Lateral Connection Plate’



7. Recommended Details to Avoid Conditions Susceptible to Constraint-Induced Fracture

- Two new tables are added to Article 6.6.1.2.4 providing recommended details to avoid conditions susceptible to constraint-induced fracture in regions subject to a net tensile stress under Strength I.

➤ Table 6.6.1.2.4-1:

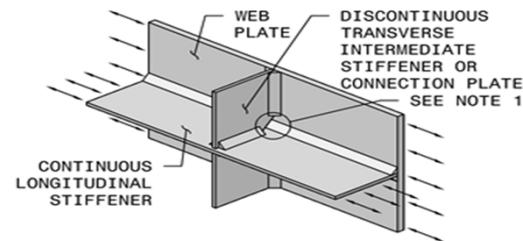

➤ Table 6.6.1.2.4-2:

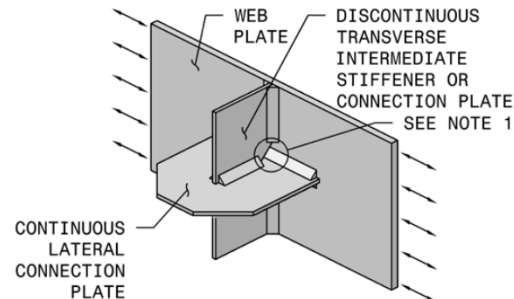

7. Recommended Details to Avoid Conditions Susceptible to Constraint-Induced Fracture

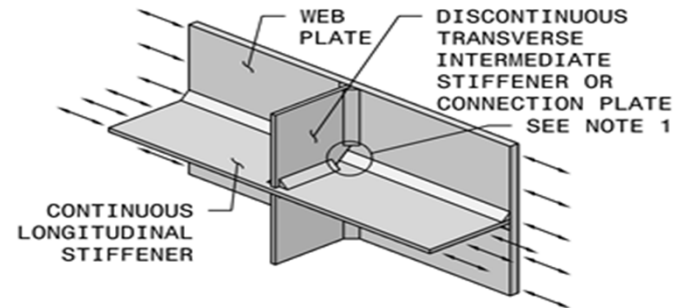

Note 1: If a gap is specified between the weld toes, the recommended minimum distance between the weld toes is $\frac{3}{4}$ in., but shall not be less than $\frac{1}{2}$ in. Larger gaps are also acceptable.

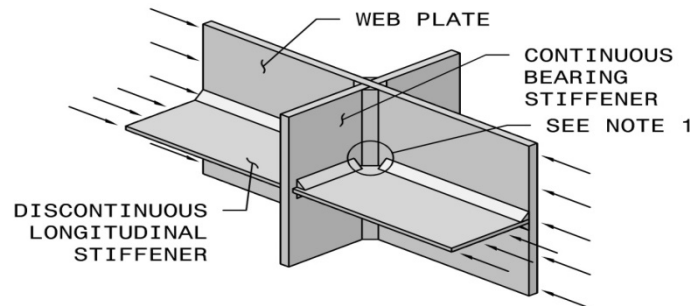

7. Recommended Details to Avoid Conditions Susceptible to Constraint-Induced Fracture

Anticipated Effect:

- Improved details at intersections of longitudinal stiffeners & lateral connection plates with vertical stiffeners should help avoid conditions susceptible to constraint-induced fracture.
- Continuous longitudinal stiffeners will be less susceptible to load-induced fatigue concerns & will perform as intended to control web bend-buckling.

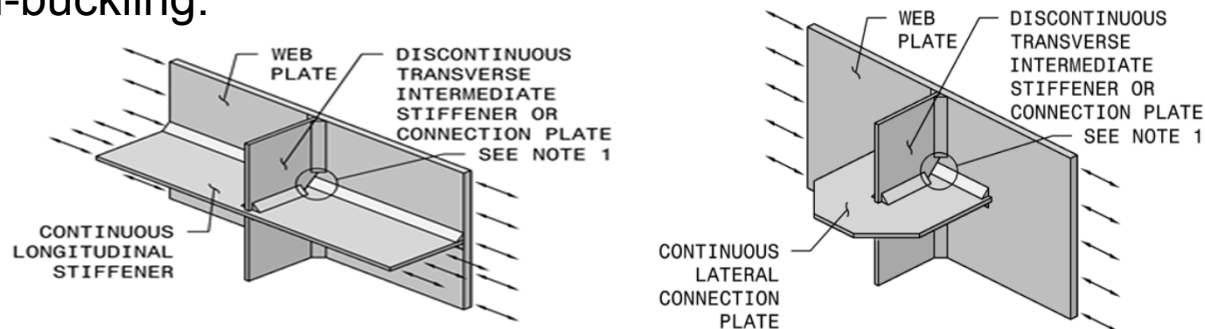

6. Increase in the Fatigue Load Factors

Description of Specification Revisions:

- The Fatigue I load factor is changed from 1.50 to 1.75 and the Fatigue II load factor is changed from 0.75 to 0.80. The commentary is revised accordingly to explain the changes.

Fatigue I— <i>LL, IM & CE</i> only	—	1.50 <u>1.75</u>	—
Fatigue II— <i>LL, IM & CE</i> only	—	0.75 <u>0.80</u>	—



6. Increase in the Fatigue Load Factors

- The values in Table 6.6.1.2.3-2 and Equation C6.6.1.2.3-1 are changed to accommodate the revised load factors.

Table 6.6.1.2.3-2—75-yr $(ADTT)_{SL}$ Equivalent to Infinite Life

Detail Category	75-yr $(ADTT)_{SL}$ Equivalent to Infinite Life (trucks per day)
A	530 <u>690</u>
B	860 <u>1120</u>
B'	1035 <u>1350</u>
C	1290 <u>1680</u>
C'	745 <u>975</u>
D	1875 <u>2450</u>
E	3530 <u>4615</u>
E'	6485 <u>8485</u>

$$\begin{aligned}
 \cancel{75_Year(ADTT)_{SL}} &= \frac{A}{\left[\frac{(\Delta F)_{TH}}{2}\right]^3 (365)(75)(n)} \\
 75_Year(ADTT)_{SL} &= \frac{A}{\left[\frac{0.80(\Delta F)_{TH}}{1.75}\right]^3 (365)(75)(n)} \quad (C6.6.1.2.3-1)
 \end{aligned}$$



6. Increase in the Fatigue Load Factors

- Table 6.6.1.2.5-2 is revised to remove the increase in number of stress cycles per truck passage for spans ≤ 40 feet.

Table 6.6.1.2.5-2—Cycles per Truck Passage, n

Longitudinal Members	Span Length	
	>40.0 ft	≤ 40.0 ft
Simple Span Girders	1.0	2.0
Continuous Girders		
1) near interior support	1.5	2.0
2) elsewhere	1.0	2.0
Cantilever Girders	5.0	

Anticipated Effect:

- Slight increase in weight of continuous-span girders due to increase in bottom-flange size in positive moment regions.
- Some additional shear connectors will likely be required.



5. Introduction of the ASTM F3125 Standard for High-Strength Bolts

Description of Specification Revisions:

- A new Article 6.4.3.1 on “High-Strength Fasteners” has been created, which introduces the new ASTM F3125 standard for high-strength bolts.
- Existing articles on nuts and washers are streamlined and refer to the F3125 standard.
- The previous article on “Load Indicator Devices” is re-named to “Direct Tension Indicators (DTIs)”.
- A new Article 6.4.3.2 has been created on “Low-Strength Steel Bolts” (ASTM A307 bolts).
- A new Article 6.4.3.3 has been created on “Fasteners for Structural Anchorage”.
 - ASTM F1554 only; nuts ASTM A563 or A194 Grade 2H
 - The term “anchor bolts” is changed to “anchor rods”.



Combined Structural Bolt Specification

ASTM

F3125-15a Standard Specification for High Strength Structural Bolts, Steel and Alloy Steel, Heat Treated, 120 ksi (830 MPa) and 150 ksi (1040 MPa) Minimum Tensile Strength, Inch and Metric Dimensions

Slides courtesy of:

Chad Larson

President - LeJeune Bolt Company

Producer Vice Chair - ASTM F16 Fastener Committee

Chair - ASTM Subcommittee F16.02 on Steel Bolts, Nuts, Rivets and Washers



25



What is F3125?



Structural Bolt Grades



Specify as an "ASTM F3125 Grade A325 bolt"



Structural Bolt Types



5. Introduction of the ASTM F3125 Standard for High-Strength Bolts

Anticipated Effect:

- Allows the use of a single specification for high-strength bolts.
- Allows for greater consistency in the specification, provision, and testing of all types of high-strength bolts.
- Single higher strength level for Grade A325 and F1852 bolts over 1 inch in diameter may make larger diameter bolts more attractive for design.



4. Revisions to the Bolt Resistance Calculations

Description of Specification Revisions:

- The built-in joint length reduction factor in lap splice tension connections is increased from 0.80 to 0.90.
- The limiting connection length for the above is decreased from 50.0 in. to 38.0 in.
- The bolt shear-to-tensile strength ratio is increased from 0.60 to 0.625.
- Result: an increase in the nominal shear resistance of high-strength bolts at the strength limit state (Article 6.13.2.7):

$$\begin{array}{l} \cancel{R_n = 0.48 A_b F_{ub} N_s} \quad R_n = 0.56 A_b F_{ub} N_s \quad (X) \\ \cancel{R_n = 0.38 A_b F_{ub} N_s} \quad R_n = 0.45 A_b F_{ub} N_s \quad (N) \end{array}$$

- For lap splice tension connections greater than 38.0 in. in length, the reduction factor is 0.75. Multiply R_n by 0.83 (or 0.75/0.90).



4. Revisions to the Bolt Resistance Calculations

- Shear resistance equation for anchor rods implicitly assumes threads are included in the shear plane since thread length is not limited.
- ASTM A 307 Grade C is eliminated.
- Joint length factor of 0.90 is not applied to anchor rods.
- Result (Article 6.13.2.12):

$$\cancel{R_n = 0.48 A_b F_{ub} N_s} \quad R_n = 0.50 A_b F_{ub} N_s \quad (N)$$

- The maximum hole size in Table 6.13.2.4.2-1 for bolts greater than or equal to 1" in diameter is increased to the nominal diameter of the bolt plus 1/8".
 - Eliminates the need to field ream holes to fit large-diameter hot forged bolts, which have a longitudinal forging seam that interferes with holes 1/16" larger than the bolt diameter.



4. Revisions to the Bolt Resistance Calculations

- The values of the surface condition factor, K_s , in Table 6.13.2.8-3 used in calculating the nominal slip resistance of a high-strength bolt in a slip-critical connection are revised as follows:

For Class A surface conditions	0.33 <u>0.30</u>
For Class B surface conditions	0.50
For Class C surface conditions	0.33 <u>0.30</u>
For Class D surface conditions	<u>0.45</u>

- The requirement to roughen hot-dip galvanized surfaces after galvanizing by hand-wire brushing has been removed.
- Unsealed thermal-sprayed pure zinc or 85/15 zinc aluminum coatings ($t_{\text{coating}} \leq 16$ mils) are classified as Class B surfaces.
- Sealed thermal-spray coatings are not included – must be qualified by test.



4. Revisions to the Bolt Resistance Calculations

Anticipated Effect:

- In general, fewer bolts will be required in high-strength bolted connections to satisfy the shear resistance provisions at the strength limit state.
- The introduction of a Class D surface condition is not anticipated to have a significant effect on the overall number of bolts and permits more coating options.
- The reduction in K_s for Class A and Class C surface conditions from 0.33 to 0.30 may potentially lead to a small increase in the number of bolts for these surface conditions since the smaller coefficient may lead to slip controlling the number of bolts (vs. strength).



3. Skewed and Curved I-Girder Bridge Fit & Framing Arrangements

- NCHRP Project 12-79: “Guidelines for Analysis Methods and Construction Engineering of Curved and Skewed Steel Girder Bridges”
- NCHRP Project 20-07, Task 355: “Guidelines for Reliable Fit-Up of Steel I-Girder Bridges”



Description of Specification Revisions:

- Introduces 9 new definitions in Article 6.2.
- States more explicitly issues to be considered in analysis for phased construction or staged deck placement when establishing girder cambers (Article 6.7.2).



3. Skewed and Curved I-Girder Bridge Fit & Framing Arrangements

- The contract documents should state the fit condition for which the cross-frames or diaphragms are to be detailed for the following I-girder bridges (Article 6.7.2):
 - Straight bridges where one or more support lines are skewed more than 20 degrees from normal;
 - Horizontally curved bridges where one or more support lines are skewed more than 20 degrees from normal and with an L/R in all spans less than or equal to 0.03; and
 - Horizontally curved bridges with or without skewed supports and with a maximum L/R greater than 0.03.

L = span length bearing to bearing along the centerline of the bridge
 R = radius of the centerline of the bridge cross-section



3. Skewed and Curved I-Girder Bridge Fit & Framing Arrangements

Fit Condition – deflected girder geometry associated with a targeted dead load condition for which the cross-frames are detailed to connect to the girders.

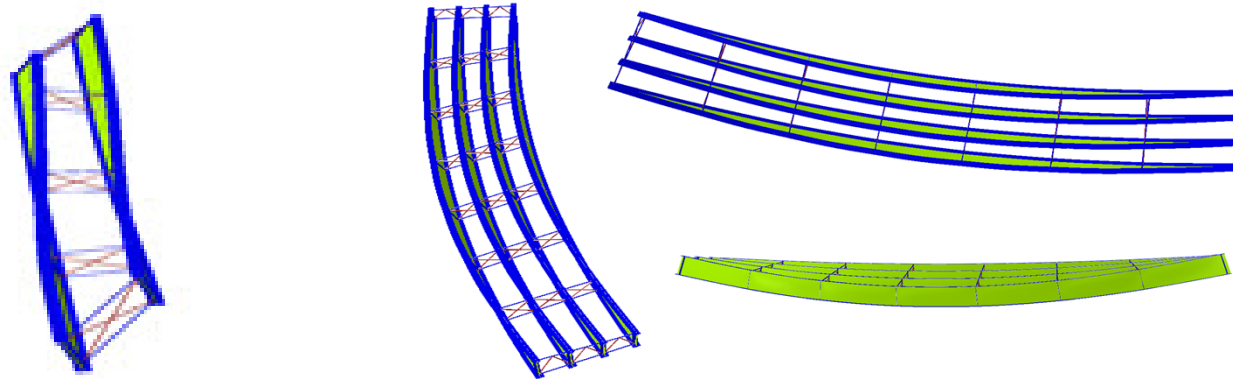

3. Skewed and Curved I-Girder Bridge Fit & Framing Arrangements

Loading Condition Fit	Construction Stage Fit	Description
No-Load Fit (NLF)	Fully-Cambered Fit	The cross-frames are detailed to fit to the girders in their fabricated, plumb, fully-cambered position under zero dead load.
Steel Dead Load Fit (SDLF)	Erected Fit	The cross-frames are detailed to fit to the girders in their ideally plumb as-deflected positions under bridge steel dead load at the completion of the erection.
Total Dead Load Fit (TDLF)	Final Fit	The cross-frames are detailed to fit to the girders in their ideally plumb as-deflected positions under the bridge total dead load.



3. Skewed and Curved I-Girder Bridge Fit & Framing Arrangements

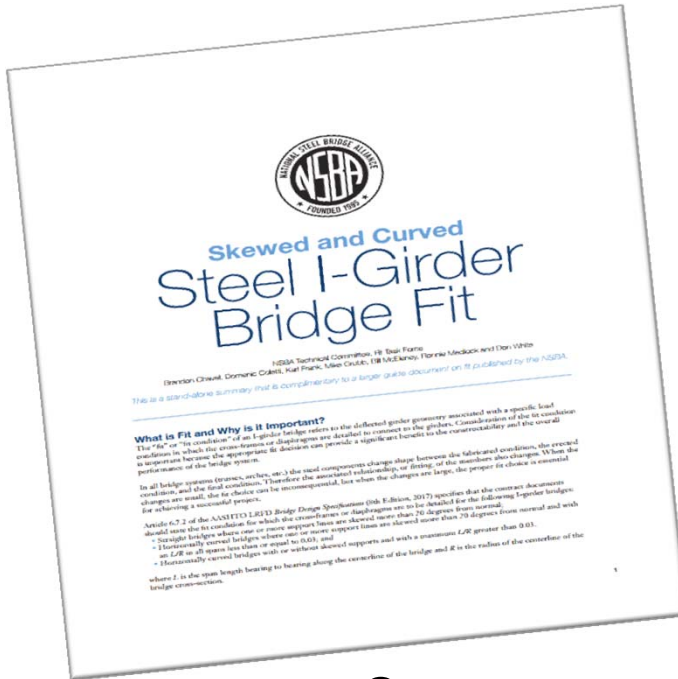

Summary



Full Document



3. Skewed and Curved I-Girder Bridge Fit & Framing Arrangements

The screenshot shows the website for the National Steel Bridge Alliance (NSBA). The navigation menu includes AISC, CERTIFICATION, MEMBERSHIP, MODERN STEEL, BRIDGES, WHY STEEL, NASCC, and a search bar. The main header features the NSBA logo and the text "NATIONAL STEEL BRIDGE ALLIANCE". Below the header, there is a breadcrumb trail: BRIDGES > PUBLICATIONS > TECHNICAL RESOURCES. On the left, a sidebar titled "IN THIS SECTION" lists: AASHTO-NSBA Collaboration, Steel Bridge Design Handbook, Modern Steel Construction Articles, and Technical Resources (highlighted with a red box). The main content area is titled "Technical Resources" and lists several documents. The document "Skewed and Curved Steel I-Girder Bridge Fit (Full Document)" is highlighted with a red box. The list includes:

- AISC/PCI Quality Systems White Paper
- A Primer on Weathering Steel
- Advances in High Performance Steels for Highway Bridges
- Bolted Field Splices for Steel Bridge Flexural Members - Overview and Design Examples
 - Release Version 1.02
 - This document address the updates to the splice connection incorporated into the 8th Edition AASHTO LRFD Specification. Complete with 3 examples, the document guides an engineer through how to design a bolted splice connection from start to finish. Utilize the document in conjunction with the updated NSBA Splice for a complete splice design.
- Edge/Corner Primer of Steel Members and its Effect on Zinc Rich Primer Performance
- I-287 Viaducts Over the Saw Mill River and Bronx Parkways
- Reducing Time for Steel Bridge Construction
- Skewed and Curved Steel I-Girder Bridge Fit (Standalone Summary)
 - The standalone summary is a 6 page overview that introduces the concept of "fit condition", why specifying fit is important, and provides recommendations as to which fit condition is best based upon bridge geometry.
- Skewed and Curved Steel I-Girder Bridge Fit (Full Document)
 - The full document addresses the research that was performed in making the recommendations for fit conditions.
- Steel Bridge Construction: Myths & Realities (AISI D432-07)
- Short Span Steel Bridge Alliance Standards
- Mid-Atlantic States Structural Committee for Economic Fabrication (SCEF) Standards
- TxDOT Preferred Practices for Steel Bridge Design Fabrication and Erection



www.steelbridges.org



3. Skewed and Curved I-Girder Bridge Fit & Framing Arrangements

Recommended Fit Conditions for Straight I-Girder Bridges
(including Curved I-Girder Bridges with L/R in all spans ≤ 0.03)

Square Bridges and Skewed Bridges up to 20 deg Skew			
	Recommended	Acceptable	Avoid
Any span length	Any		None
Skewed Bridges with Skew > 20 deg and $I_s \leq 0.30$ +/-			
	Recommended	Acceptable	Avoid
Any span length	TDLF or SDLF		NLF
Skewed Bridges with Skew > 20 deg and $I_s > 0.30$ +/-			
	Recommended	Acceptable	Avoid
Span lengths up to 200' +/-	SDLF	TDLF	NLF
Span lengths greater than 200' +/-	SDLF		TDLF & NLF



3. Skewed and Curved I-Girder Bridge Fit & Framing Arrangements

Square Bridges and Skewed Bridges up to 20 degree +/- Skew

	Recommended	Acceptable	Avoid
Any span length	Any		None

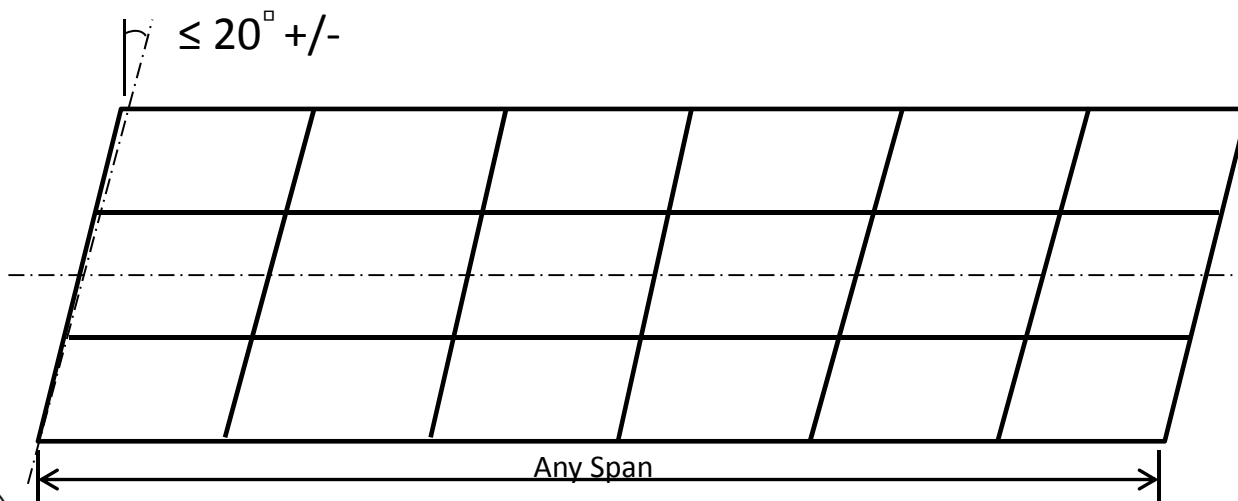

3. Skewed and Curved I-Girder Bridge Fit & Framing Arrangements

Skewed Bridges with Skew > 20 degrees +/- and $I_s \leq 0.30$ +/-

	Recommended	Acceptable	Avoid
Any span length	TDLF or SDLF		NLF

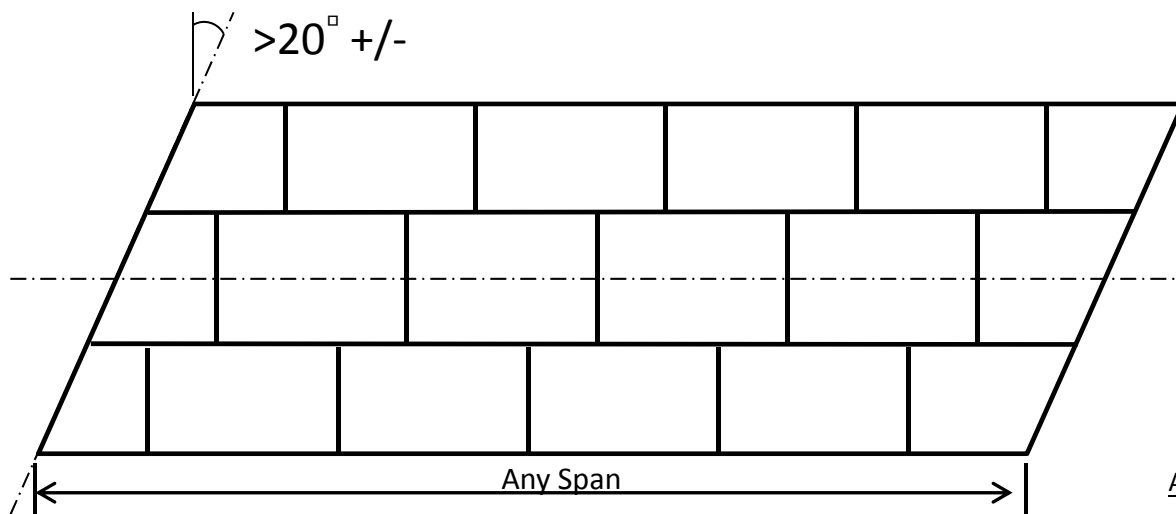

$$I_s = \frac{w_g \tan \theta}{L_s}$$

AASHTO LRFD Eq. 4.6.3.3.2-2

42



3. Skewed and Curved I-Girder Bridge Fit & Framing Arrangements

Skewed Bridges with Skew > 20 degrees +/- and $I_s > 0.30$ +/-

	Recommended	Acceptable	Avoid
Span lengths up to 200 feet +/-	SDLF	TDLF	NLF
Span lengths greater than 200 feet +/-	SDLF		TDLF & NLF

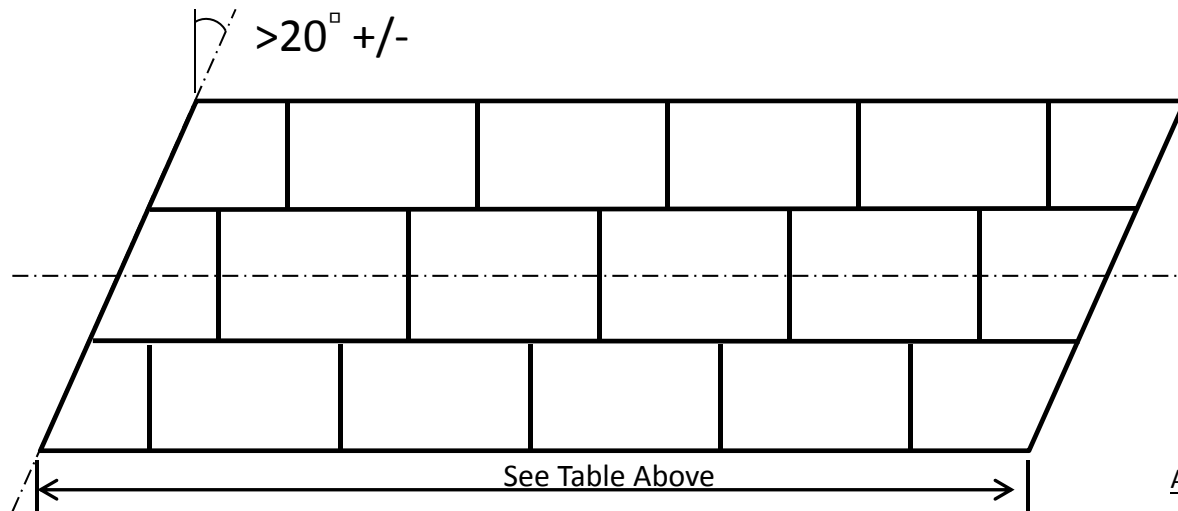

$$I_s = \frac{w_g \tan \theta}{L_s}$$

AASHTO LRFD Eq. 4.6.3.3.2-2

43



3. Skewed and Curved I-Girder Bridge Fit & Framing Arrangements

Recommended Fit Conditions for Horizontally Curved I-Girder Bridges
 $((L/R)_{MAX} > 0.03)$

Radial or Skewed Supports			
	Recommended	Acceptable	Avoid
$(L/R)_{MAX} \geq 0.2$	NLF	SDLF	TDLF
All other cases	SDLF	NLF	TDLF

- Total Dead Load Fit should not be specified for curved I-girder bridges with or without skew and with a maximum L/R greater than 0.03.
- Detail for a Steel Dead Load Fit, unless than maximum L/R is greater than or equal to 0.2.
- When $(L/R)_{MAX} \geq 0.2$, detail for No-Load Fit, unless the additive locked-in force effects from Steel Dead Load Fit detailing are considered.



3. Skewed and Curved I-Girder Bridge Fit & Framing Arrangements

- Bullet item added in Article 6.7.4.1 to emphasize importance of cross-frames in controlling torsional stresses & rotations due to eccentric deck overhang loads.
- Language added to Article C6.7.4.2 to discuss beneficial framing arrangements in skewed and curved I-girder bridges to alleviate detrimental transverse stiffness effects.
- Revision made to recommended offset of first intermediate cross-frame placed normal to the girders adjacent to a skewed support:

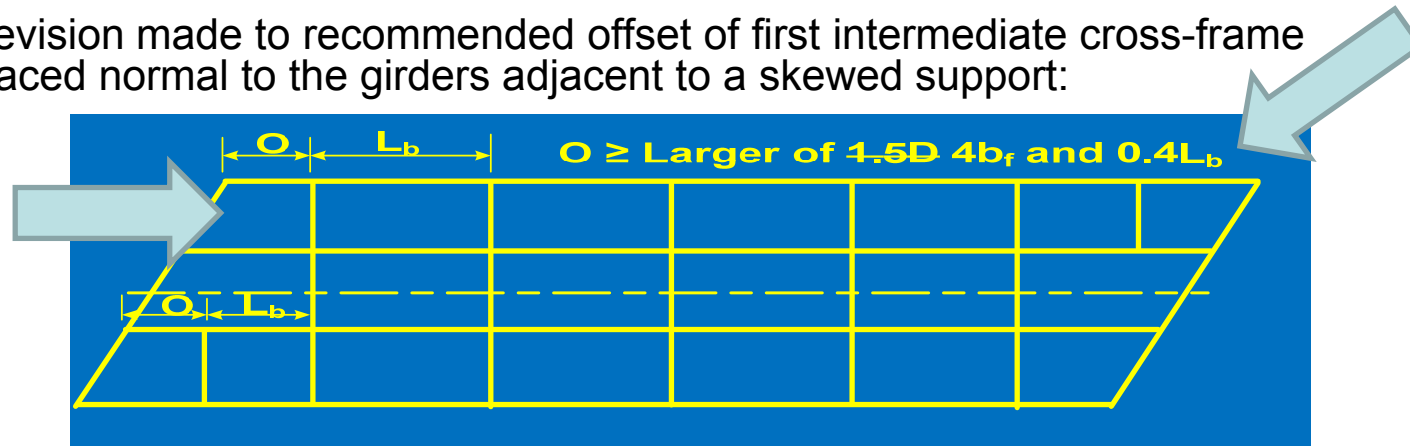

3. Skewed and Curved I-Girder Bridge Fit & Framing Arrangements

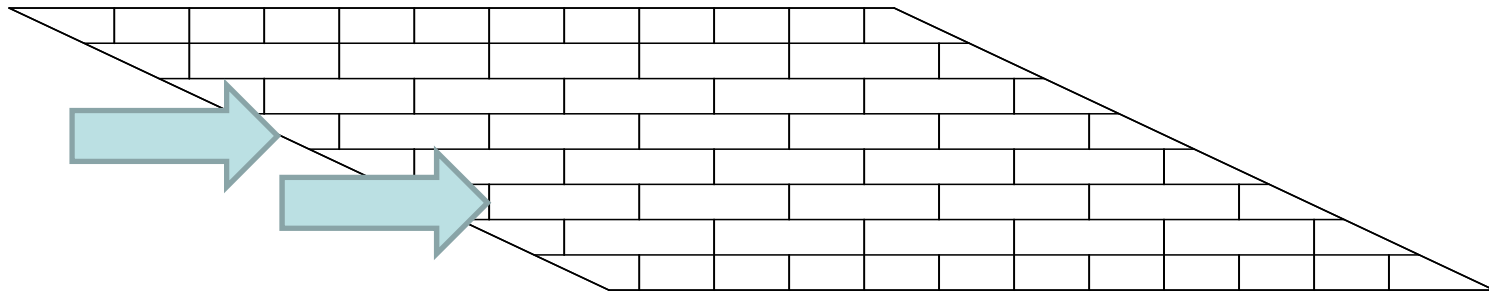

- Framing of a normal intermediate cross-frame into or near a bearing location along a skewed support line is strongly discouraged unless the cross-frame diagonals are omitted.
- At skewed interior piers & abutments, place cross-frames along the skewed bearing line, and locate intermediate cross-frames greater than or equal to the recommended minimum offset from the bearing lines.
- For curved I-girder bridges, provide contiguous intermediate cross-frame lines within the span in combination with the recommended offset at skewed bearing lines.



3. Skewed and Curved Girder Bridge Fit & Framing Arrangements

Anticipated Effect:

- Stronger understanding of the implications of dead load camber and cross-frame detailing methods for skewed and curved bridges.
- Safer and more consistent practices to reduce the possibility of construction delays and claims.
- Use of a Total Dead Load Fit discouraged for curved I-girder bridges with a maximum L/R greater than 0.03.
- Stronger understanding of the implications of various framing arrangements for skewed and curved I-girder bridges.
- Greater avoidance of detrimental transverse stiffness effects in sharply skewed bridge spans.
- Achieve design economies by reducing the number of cross-frames and avoiding the large transverse stiffness load paths.



2. Primary vs. Secondary Members, Charpy Requirements, FCMs & SRMs

Description of Specification Revisions:

~~*Fracture-Critical Member (FCM)*—Component in tension whose failure is expected to result in the collapse of the bridge or the inability of the bridge to perform its function. A steel primary member or portion thereof subject to tension whose failure would probably cause a portion of or the entire bridge to collapse.~~

~~*Primary Member*—A member designed to carry the internal forces determined from an analysis. A steel member or component that transmits gravity loads through a necessary as-designed load path. These members are therefore subjected to more stringent fabrication and testing requirements; considered synonymous with the term “main member”.~~

~~*Secondary Member*—A member in which stress is not normally evaluated in the analysis. A steel member or component that does not transmit gravity loads through a necessary as-designed load path.~~



2. Primary vs. Secondary Members, Charpy Requirements, FCMs & SRMs

– A new Article 6.6.2.1 entitled ‘Member or Component Designations & Charpy V-Notch Testing Requirements’ is introduced.

- A new Table 6.6.2.1-1 is provided designating various members or components as primary or secondary.
- Primary members subject to a net tensile stress under Strength I are to be designated on the contract plans.
- Charpy V-notch testing is required for primary members subject to a net tensile stress under Strength I, *except for diaphragm and cross-frame members and mechanically fastened or welded cross-frame gusset plates in horizontally curved bridges.*

Member or Component Description	Member or Component Designation
Girders, beams, stringers, floorbeams, bent caps, bulkheads, and straddle beams	Primary
Truss chords, diagonals, verticals, and portal and sway bracing members	Primary
Arch ribs and built-up or welded tie girders	Primary
Rigid frames	Primary
Gusset plates and splice plates in trusses, arch ribs, tie girders, and rigid frames	Primary
Splice plates and cover plates in girders, beams, stringers, floorbeams, bent caps, and straddle beams	Primary
Bracing members supporting arch ribs	Primary
Permanent bottom-flange lateral bracing members and mechanically fastened or welded bottom-flange lateral connection plates in straight and horizontally curved bridges	Primary
Diaphragm, cross-frame, and top-flange lateral bracing members, struts, and mechanically fastened or welded cross-frame gusset plates and top-flange lateral connection plates in straight and horizontally curved bridges	Secondary
Diaphragm and cross-frame members, and mechanically fastened or welded cross-frame gusset plates and bearing stiffeners at supports in bridges located in Seismic Zones 3 or 4	Primary
Bearings, filler plates, sole plates, and masonry plates	Secondary
Mechanically fastened or welded longitudinal web and flange stiffeners	Primary
Mechanically fastened or welded transverse intermediate web stiffeners, transverse flange stiffeners, bearing stiffeners, and vertical and lateral connection plates	Secondary

49



2. Primary vs. Secondary Members, Charpy Requirements, FCMs & SRMs

- A new Article 6.6.2.2 entitled ‘Fracture-Critical Members (FCMs)’ is introduced.
 - Contains all existing requirements related to FCMs.
 - *Primary* members that are FCMs are to be designated on the contract plans.
 - Members not subject to a net tensile stress under Strength I are not to be designated as FCMs.

System Redundant Member (SRM)—A steel primary member or portion thereof subject to tension for which the redundancy is not known by engineering judgment, but which is demonstrated to have redundancy through a refined analysis. SRMs must be identified and designated as such by the Engineer on the contract plans, and designated in the contract documents to be fabricated according to Clause 12 of the *AASHTO/AWS D1.5M/D1.5 Bridge Welding Code*. An SRM need not be subject to the hands-on in-service inspection protocol for a FCM as described in 23 CFR 650.



2. Primary vs. Secondary Members, Charpy Requirements, FCMs & SRMs

Anticipated Effect:

- Enhanced communication between the Engineer and the Fabricator in identifying primary & secondary members, and primary members and portions thereof subject to tension.
- Greater clarity is provided related to the identification of FCMs.
- Introduction of the concept of System Redundant Members (SRMs) into the specifications.
- Greater economy should result from reducing the need for more costly fabrication & testing requirements for certain members that add little or no value.



1. New Simplified Bolted Splice Design Procedure

Description of Specification Revisions:

- Removes the applicability of the 75 percent and average rules in Article 6.13.1 to the design of bolted and welded splices for flexural members.
 - Rules are applicable to connections and splices for primary members subject to axial tension or compression only.
 - Clarifies the application of the rules to primary members subjected to force effects acting in multiple directions due to combined loading.
- ***Implements a new simplified bolted splice design procedure for flexural members within Article 6.13.6.1.***



Expensive and Slow to Erect Field Splices



Expensive Tub Girder Splice



Cost-Effective Splice Design

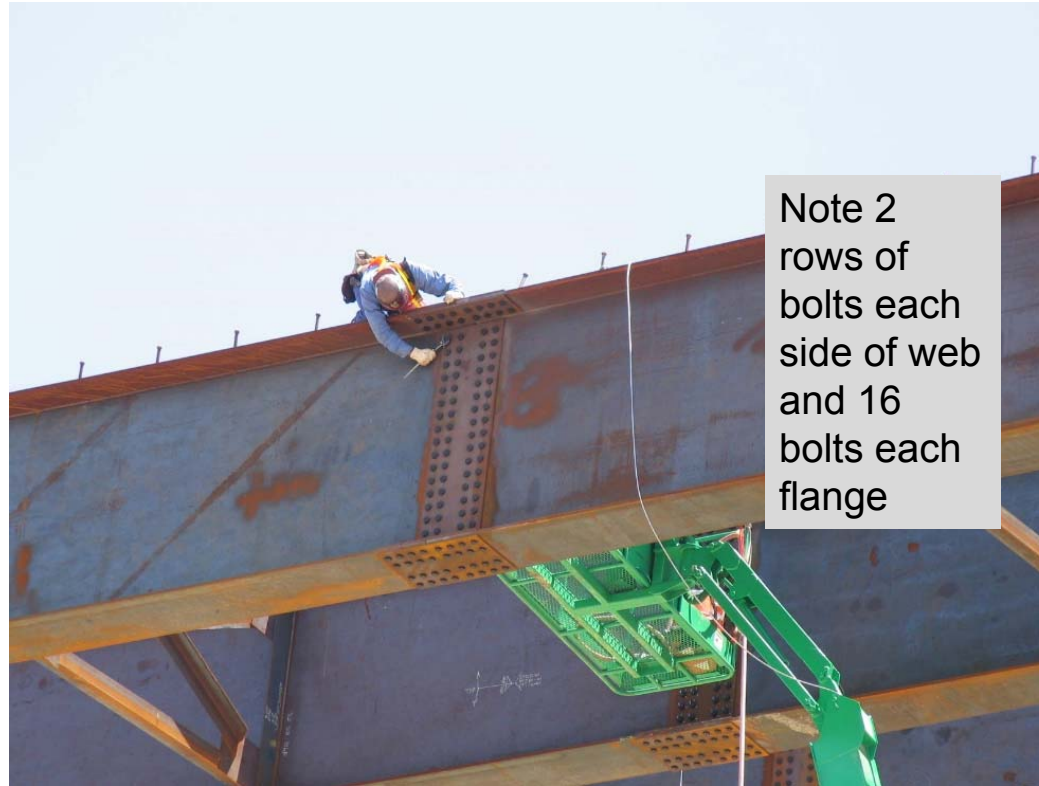

Note 2
rows of
bolts each
side of web
and 16
bolts each
flange



Design Comparisons

Girder Depth In.	Required Number of Bolts on One Side			
	Number of Top Flange Bolts	Number of Web Bolts	Number of Bottom Flange Bolts	Difference Previous vs. New Simplified
72	12	36	24	6
	16	22	28	
111	24	102	28	36
	20	70	28	
80 Tub Girder	16	34	54	-7
	20	28	63	



NSBA Splice Spreadsheet - Input

NSBA Bolted Splice Designer - Plate Girder

Design Input

	Moment (kip-ft)	Shear (kip)
Noncomposite Dead Load (DC ₁)	248.00	-82.00
Superimposed Composite Dead Load (DC ₂)	50.00	-12.00
Future Wearing Surface (DW)	52.00	-11.00
Positive Live Load plus Impact (LL ⁺ + I)	2469.00	19.00
Negative Live Load plus Impact (LL ⁻ + I)	-1754.00	-112.00
Deck Casting	1300.00	-82.00

Bolt Properties

Bolt Type	A325	
Bolt Diameter (in)	7/8	
Web Threads	Included	
Flange Threads	Excluded	
Surface Condition Factor (K _s)	B	
Hole Size Factor (K _h)	Standard	
Top Flange Rows	4	OK
Web Rows	2	OK
Bottom Flange Rows	4	OK

Girder Properties

	Left	Right
Top Flange Material	Grade 50W	HPS Grade 70W
Top Flange Thickness (in)	1	1
Top Flange Width (in)	16	18
Web Material	Grade 50W	Grade 50W
Web Thickness (in)	1/2	9/16
Web Depth (in)	69	

Concrete Deck Properties

Composite	Composite
Thickness (in)	9
Haunch (in)	0

Spacing and Clearance Values



www.steelbridges.org/NsbaSplice



NSBA Splice Spreadsheet – Flange Splice Calculations

 **NSBA Bolted Splice Designer - Plate Girder** NOTICE: DO NOT MODIFY THIS SHEET

Flange Calculations

Load Combinations - Factored Moment

Load Combination	Moment (kip-ft)						Factored (kip-ft)
	Noncomposite Dead Load (DC1)	Superimposed Composite Dead Load (DC2)	Future Wearing Surface (DW)	Positive Live Load plus Impact (LL+ I)	Negative Live Load plus Impact (LL- + I)	Deck Casting	
Deck Casting	0.00	0.00	0.00	2469.00	0.00	1.40	1,820.00
Strength I - Positive	1.25	1.25	1.50	1.75	0.00	0.00	4,771.25
Strength I - Negative	0.90	0.90	0.65	0.00	1.75	0.00	-2,767.50
Service II - Positive	1.00	1.00	1.00	1.30	0.00	0.00	3,559.70
Service II - Negative	1.00	1.00	1.00	0.00	1.30	0.00	-1,930.20

Bolt Factored Shear Resistance

Location	Bolt Type	Bolt Area (sq-in)	K_h	ϕ_s	F_u (ksi)	P_t (kip)	R_r - Single Shear (kip)	R_r - D
Flange	A325 - Excluded	0.6013	Standard	0.80	120	39.00	32.33	

Bolt Nominal Slip Resistance

Surface Condition Factor (K_s)	Hole Size Factor (K_h)	P_t (kip)	R_n - Double Shear (kip)
0.50	1.00	39.00	39.00

Strength Limit State Design

Location	F_y (ksi)	F_u (ksi)	$0.84 (F_u/F_y)$	Width (in)	Thickness (in)	Filler Plate Thickness (in)

Navigation: EULA | Input | Figures | Design Result Summary | Design Check Summary | **Flange Splice Design** | Web Splice Design



www.steelbridges.org/NsbaSplice



NSBA Splice Spreadsheet – Web Splice Calculations

 **NSBA Bolted Splice Designer - Plate Girder** NOTICE: DO NOT MODIFY THIS SHEET

Web Calculations

Load Combinations - Factored Shear

	Shear (kip)						Factored Shear (kip)
	Noncomposite Dead Load (DC1)	Superimposed Composite Dead Load (DC2)	Future Wearing Surface (DW)	Positive Live Load plus Impact (LL+ I)	Negative Live Load plus Impact (LL- + I)	Deck Casting	
Load Combination	-82.00	-12.00	-11.00	19.00	-112.00	-82.00	
Deck Casting	0.00	0.00	0.00	0.00	0.00	1.40	-114.80
Service II - Positive	1.00	1.00	1.00	1.30	0.00	0.00	-80.30
Service II - Negative	1.00	1.00	1.00	0.00	1.30	0.00	-250.60

Bolt Factored Shear Resistance

Location	Bolt Type	Bolt Area (sq-in)	K_h	ϕ_s	F_u (ksi)	P_t (kip)	R_r - Single Shear (kip)
Web	A325 - Included	0.6013	Standard	0.80	120	39.00	25.98

Bolt Nominal Slip Resistance

Faying Surface Class (K_s)	Hole Size Factor (K_h)	P_t (kip)	Slip Capacity - Double (kip)
0.50	1.00	39.00	39.00

Flange Design Results

Flange Moment Resistance Check Results

	H_w (kip)	Controlling
Positive	DNA	
Negative	DNA	

Navigation: EULA | Input | Floures | Design Result Summary | Design Check Summary | Flange Splice Design | **Web Splice Design**



www.steelbridges.org/NsbaSplice



NSBA Splice Spreadsheet – Design Result Summary

NSBA Bolted Splice Designer - Plate Girder

Design Result Summary

Cell Fill Color
 User Input Field
 Spreadsheet Status Field
 Spreadsheet Calculated Field

NOTICE: DO NOT MODIFY THIS SHEET

Bolts Arrangement

	Bolt Rows (Per Side)	Total Bolts (Per Side)
Top Flange	4	12
Web	2	26
Bottom Flange	4	24

	Gage - Bolts (in)	Edge Distance (in)	Pitch - Bolts (in)	End Distance (in)	Gage - Bolt Groups (in)	Pitch - Bolt Groups (in)
Top Flange	3	2	3	1 1/2	6	3 3/4
Web	3	2	5 1/8	1 1/2	4 3/4	DNA
Bottom Flange	4	2	3	1 1/2	6	3 3/4

Splice Plate Dimensions

	Thickness (in)	Width (in)	Length (in)
Top Flange - Outer	5/8	16	18 3/4
Top Flange - Inner (Each)	11/16	7	
Top Filler	0	0	0
Web	3/8	14 3/4	64 1/2
Web Filler	0	0	0
Bottom Flange - Inner (Each)	7/8	8	



www.steelbridges.org/NsbaSplice



NSBA Splice Spreadsheet – Design Check Summary

NSBA Bolted Splice Designer - Plate Girder

Design Check Summary

Cell Fill Color:
 Orange: User Input Field
 Green: Spreadsheet Status Field
 Yellow: Spreadsheet Status Field
 Red: Spreadsheet Status Field
 Grey: Spreadsheet Calculated Field

NOTICE: DO NOT MODIFY THIS SHEET

Design Check Status

Flange Splice

	Factored Yield Resistance Check - Tension	Net Section Fracture Check - Tension	Check $A_n \leq 0.85 A_g$ AASHTO 6.13.5.2	Block Shear Rupture Resistance
Top Flange - Outer Splice Plate	OK	OK	OK	OK
Top Flange - Inner Splice Plate	OK	OK	OK	OK
Bottom Flange - Inner Splice Plate	OK	OK	OK	OK
Bottom Flange - Outer Splice Plate	OK	OK	OK	OK

	Block Shear Rupture Resistance - Mode 1	Block Shear Rupture Resistance - Mode 2	Bearing Resistance
Top Flange - Left	OK	OK	OK
Top Flange - Right	OK	OK	
Bottom Flange - Left	OK	OK	OK
Bottom Flange - Right	OK	OK	

Splice Plate A_g Check - Top Flange	OK
Splice Plate Area A_g - Bottom Flange	OK



www.steelbridges.org/NsbaSplice



Summary



10. Increase in Maximum Shear Connector Spacing
9. Global Displacement Amplification of Narrow I-Girder Systems
8. Introduction of the Unified Effective Width Approach
7. Recommended Details to Avoid Conditions Susceptible to Constraint-Induced Fracture
6. Increase in the Fatigue Load Factors



Summary



5. Introduction of the ASTM F3125 Standard for High-Strength Bolts
4. Revisions to the Bolt Resistance Calculations
3. Skewed and Curved I-Girder Bridge Fit & Framing Arrangements
2. Primary vs. Secondary Members, Charpy Requirements, FCMs & SRMs
1. New Simplified Bolted Splice Design Procedure



Quiz Question 1

Which fit condition should be avoided for curved I-girder bridges with a maximum L/R greater than 0.03?

- a. No-Load Fit (NLF)
- b. Total Dead Load Fit (TDLF)
- c. Erected Fit
- d. Steel Dead Load Fit (SDLF)



Quiz Question 2

What is the name of the new unified standard for high-strength bolts?

- a. A709
- b. F1554
- c. F3125
- d. F1852



67



Questions?



PDH Certificates

Within 2 business days...

- You will receive an email on how to report attendance from: registration@aisc.org.
- Be on the lookout: Check your spam filter! Check your junk folder!
- Completely fill out online form. Don't forget to check the boxes next to each attendee's name!



PDH Certificates

Within 2 business days...

- Reporting site (URL will be provided in the forthcoming email).
- Username: Same as AISC website username.
- Password: Same as AISC website password.



There's always a solution in steel.

Thank You

Please give us your feedback!
Survey at conclusion of webinar.

