

AISC Live Webinars

Thank you for joining our live webinar today.
We will begin shortly. Please standby.

Basic Steel Design
Session L1: Tension Members
February 25, 2021



AISC Live Webinars

Today's live webinar will begin shortly. Please stand by.

Today's audio will be broadcast through the internet. Please be sure to turn up the volume on your speakers.

Please type any questions or comments in the Q&A window.



AISC Live Webinars

AIA Credit

AISC is a Registered Provider with The American Institute of Architects Continuing Education Systems (AIA/CES). Credit(s) earned on completion of this program will be reported to AIA/CES for AIA members. Certificates of Completion for both AIA members and non-AIA members are available upon request.

This program is registered with AIA/CES for continuing professional education. As such, it does not include content that may be deemed or construed to be an approval or endorsement by the AIA of any material of construction or any method or manner of handling, using, distributing, or dealing in any material or product.

Questions related to specific materials, methods, and services will be addressed at the conclusion of this presentation.



AISC Live Webinars

Copyright Materials

This presentation is protected by US and International Copyright laws. Reproduction, distribution, display and use of the presentation without written permission of AISC is prohibited.

© The American Institute of Steel Construction 2021

The information presented herein is based on recognized engineering principles and is for general information only. While it is believed to be accurate, this information should not be applied to any specific application without competent professional examination and verification by a licensed professional engineer. Anyone making use of this information assumes all liability arising from such use.



AISC Live Webinars

Course Description

Tension Members

This lecture will focus on the design of structural steel tension members and the associated provisions in the AISC *Specification*. The session will begin with a discussion of strength, calculating area and available strength of tension members. Emphasis will then be placed on designing tension members before discussing the concept of block shear. The session concludes with an overview of eyebars, pin connected members, truss members and braces. Several design examples will be presented.



AISC Live Webinars

Learning Objectives

- List the limit state that must be checked for the design of tension members.
- Compare the use of gross area, net area and effective net area in the design of structural steel tension members.
- List the unique design requirements for eyebars and pin connected members.
- Demonstrate the design of tension members through a design example.



Basic Steel Design: A review of the principles of steel design according to ANSI/AISC 360-16

Winter Webinar 2021
Lesson L1
Tension Members



L1.7

Lesson L1 – Tension Members

- Tension Members
 - Strength
 - Area calculations
 - Available strength
 - Design
 - Block shear
 - Eyebars and pin connected members



L1.8

Tension Members

B3.1. For LRFD, design shall be performed in accordance with:

Required Strength \leq Available Strength

$$R_u \leq \phi R_n \quad (\text{B3-1})$$

where

R_u = required strength (LRFD) defined in Chapter C

R_n = nominal strength specified in Chapter D

ϕ = resistance factor specified in Chapter D

ϕR_n = design strength = resistance factor (nominal strength)



L1.9

Tension Members

B3.2. For ASD, design shall be performed in accordance with:

Required Strength \leq Available Strength

$$R_a \leq R_n / \Omega \quad (\text{B3-2})$$

where

R_a = required strength (ASD) defined in Chapter C

R_n = nominal strength specified in Chapter D

Ω = safety factor specified in Chapter D

R_n / Ω = allowable strength = $\frac{\text{nominal strength}}{\text{safety factor}}$



L1.10

Tension Members

D2. "The design tensile strength, $\phi_t P_n$, and the allowable tensile strength, P_n / Ω_t , of tension members, shall be the lower value obtained according to the limit states of **tensile yielding** in the gross section and **tensile rupture** in the net section."



L1.11

Steel as a Material

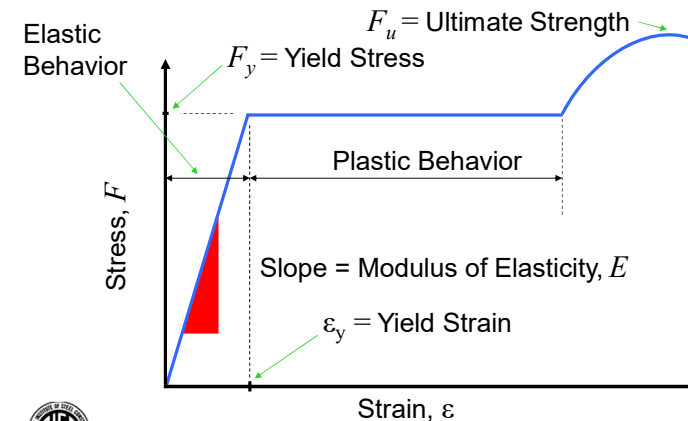

L1.12

Tension Members

- Tensile Test Specimen

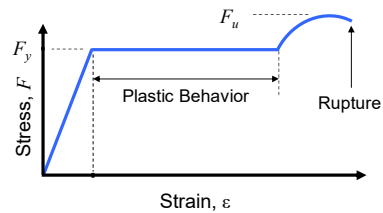

L1.13

Tension Members

Two limit states to be considered for tension

D2.(a) Nominal Strength for Yielding;

$$P_n = F_y A_g \quad (D2-1)$$

$$\phi_t = 0.90 \text{ (LRFD)} \quad \Omega_t = 1.67 \text{ (ASD)}$$



L1.14

Tension Members

Two limit states to be considered for tension

D2.(b) Nominal Strength for Rupture

$$P_n = F_u A_e \quad (D2-2)$$

$$\phi_t = 0.75 \text{ (LRFD)} \quad \Omega_t = 2.00 \text{ (ASD)}$$



L1.15

Design for Tension

- Allowable Strength (ASD), $P_a \leq \frac{P_n}{\Omega}$;

$$P_a \leq 0.6 F_y A_g$$

$$\leq 0.5 F_u A_e$$



L1.16

Tension Members

- Design Strength (LRFD), $P_u \leq \phi P_n$

$$P_u \leq 0.9F_y A_g$$

$$\leq 0.75F_u A_e$$



L1.17

Area Calculations

- Three different areas are defined for use in design of tension members.
 - Gross Area, A_g
 - Net Area, A_n
 - Effective Net Area, A_e



L1.18

B4.3a. Gross Area, A_g

- “The gross area, A_g , of a member is the total cross-sectional area.”

$A_g = A$

Table 1-7
Angles
Properties

Shape	k	Wt. lb/ft	Area, A in. ²	Axis X-X						Flexura Prop.	
				I in. ⁴	S in. ³	r in.	\bar{y} in.	Z in. ³	J in. ⁴	J in. ⁴	P in.
L8-x8x1/8	1 1/4	56.9	16.8	98.1	17.5	2.41	2.40	31.6	1.05	7.13	32
x1	1 1/8	51.0	15.1	89.1	15.8	2.43	2.36	28.5	0.944	5.08	23
x7/8	1 1/2	45.0	13.3	79.7	14.0	2.45	2.31	25.3	0.831	3.46	16
x3/4	1 3/4	38.9	11.5	69.9	12.2	2.46	2.26	22.0	0.719	2.21	11



L1.19

B4.3b. Net Area, A_n

- Net area accounts for holes in the member
- In the simplest case it is the gross area less the area of holes, $(d_b + 1/16" + 1/16")t$
 - d_b = bolt diameter
 - t = element thickness
 - $(d_b + 1/16 \text{ in.})$ = the hole size for standard holes and bolts less than 1.0 in. in diameter
 - The other 1/16 in. is to account for damage to the element due to punching of the hole



L1.20

B4.3b. Net Area, A_n

- Net area accounts for holes in the member
- In the simplest case it is the gross area less the area of holes, $(d_b + 1/16" + 1/16")t$

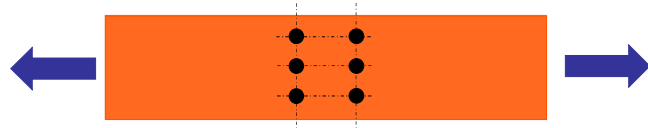

L1.21

B4.3b. Net Area, A_n

- For HSS with slots, deduct full width of the slots times the thickness



- For members without holes, $A_n = A_g$



L1.22

B4.3b. Net Area, A_n

- Look at the transverse section and determine the amount to be deducted

6 - 3/4 in. bolts $A_g = tb = 0.5(8.0) = 4.0 \text{ in.}^2$
 8 in. plate width
 1/2 in. plate thickness $A_n = 4.0 - 3\left(\frac{3}{4} + \frac{1}{16} + \frac{1}{16}\right)(0.5) = 2.69 \text{ in.}^2$

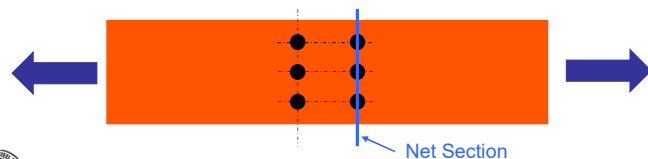

L1.23

B4.3b. Net Area, A_n

- What happens if the bolts are staggered?

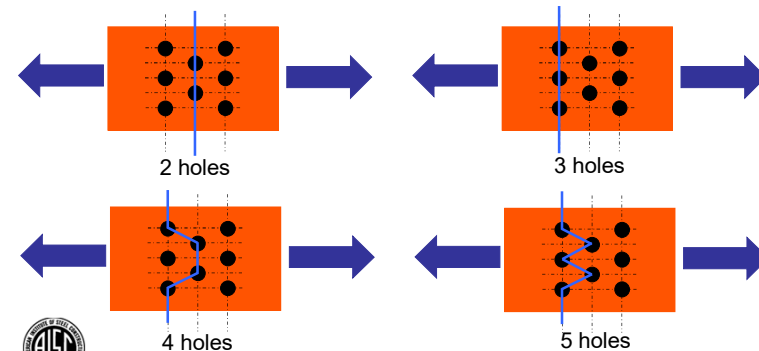

L1.24

B4.3b. Net Area, A_n

- Look at the chain (path) if we are to deduct for 4 holes.

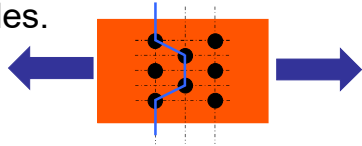

- There is more area to resist the force along the diagonals than if the holes were all in a straight line. So, after we deduct the 4 holes we must add something back.



L1.25

B4.3b. Net Area, A_n

Net width = gross plate width less the holes plus the term $s^2/4g$ for each diagonal path where s is the hole spacing and g is the gage

$$b_n = b - n \left(d_h + \frac{1}{16} \right) + \sum \frac{s^2}{4g}$$

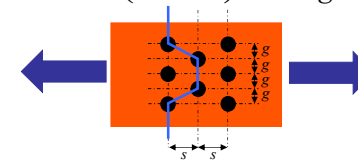

L1.26

B4.3b. Net Area, A_n

Consider a plate width of 11.0 in.
Holes for 5/8 in. bolts
Spacing of 4.0 in.
Gage of 2.0 in.

$$b_n = b - n \left(d_h + \frac{1}{16} \right) + \sum \frac{s^2}{4g}$$

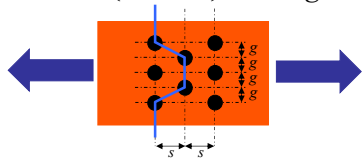

L1.27

B4.3b. Net Area, A_n

Look at the 4 possible chains

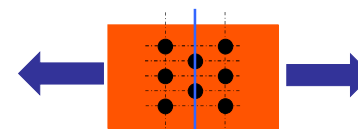

$$b_{n2} = 11.0 - 2 \left(\frac{5}{8} + \frac{1}{16} + \frac{1}{16} \right) = 11.0 - 1.5 = 9.5 \text{ in.}$$

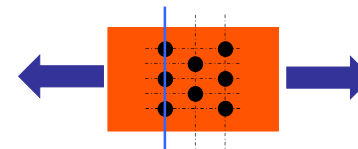

$$b_{n3} = 11.0 - 3 \left(\frac{5}{8} + \frac{1}{16} + \frac{1}{16} \right) = 11.0 - 2.25 = 8.75 \text{ in.}$$



L1.28

B4.3b. Net Area, A_n

Look at the 4 possible chains

$$b_{n4} = 11.0 - 4\left(\frac{5}{8} + \frac{1}{16} + \frac{1}{16}\right) + 2\left(\frac{4^2}{4(2)}\right)$$

$$= 11.0 - 3.0 + 4 = 12.0 \leq 11.0$$

$$b_{n5} = 11.0 - 5\left(\frac{5}{8} + \frac{1}{16} + \frac{1}{16}\right) + 4\left(\frac{4^2}{4(2)}\right)$$

$$= 11.0 - 3.75 + 8.0 = 15.3 \leq 11.0$$

Therefore, $b_{n3} = 8.75$ in. controls

L1.29

B4.3b. Net Area, A_n

Consider what would happen if the vertical lines of bolt holes were spaced only 2.0 in. apart

$$b_{n4} = 11.0 - 4\left(\frac{5}{8} + \frac{1}{16} + \frac{1}{16}\right) + 2\left(\frac{2^2}{4(2)}\right)$$

$$= 11.0 - 3.0 + 1 = 9.0$$

Now both chains show an area reduction

$$b_{n5} = 11.0 - 5\left(\frac{5}{8} + \frac{1}{16} + \frac{1}{16}\right) + 4\left(\frac{2^2}{4(2)}\right)$$

$$= 11.0 - 3.75 + 2.0 = 9.25$$

But, $b_{n3} = 8.75$ in. still controls

L1.30

B4.3b. Net Area, A_n

But what if each vertical line only contained 2 holes. The gage is 2 in. and the spacing is 2.0 in.

$$b_{n2} = 11.0 - 2\left(\frac{5}{8} + \frac{1}{16} + \frac{1}{16}\right)$$

$$= 11.0 - 1.5 = 9.5 \text{ in.}$$

$$b_{n4} = 11.0 - 4\left(\frac{5}{8} + \frac{1}{16} + \frac{1}{16}\right) + 2\left(\frac{2^2}{4(2)}\right)$$

$$= 11.0 - 3.0 + 1 = 9.0$$

Therefore, $b_{n4} = 9.0$ in. now controls

L1.31

D3. Effective Net Area, A_e

$$A_e = A_n U \quad (D3-1)$$

- U is the shear lag factor
- It accounts for unattached elements of a tension member at a connection



L1.32

D3. Effective Net Area, A_e

$$A_e = A_n U \quad (D3-1)$$

- Account for unattached element
 - Examples: stem of T or outstanding leg of angle

l is defined here for a welded connection

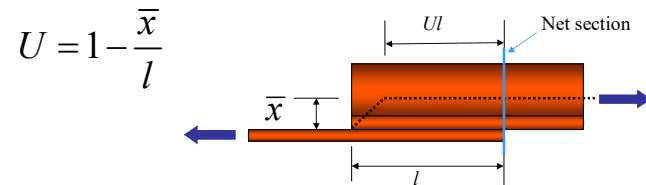

L1.33

D3. Effective Net Area, A_e

$$A_e = A_n U \quad (D3-1)$$

- Account for unattached element
 - Examples: stem of T or outstanding leg of angle

l is defined here for a bolted connection

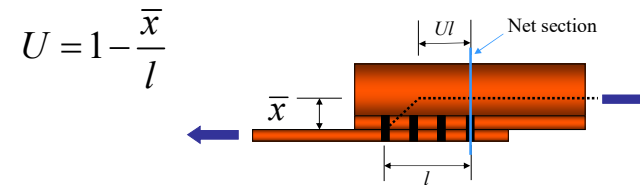

L1.34

Table D3.1

Case	Description of Element	Shear Lag Factor, U	Example
1	All tension members where the tension load is transmitted directly to each of the cross-sectional elements by fasteners or welds (except as in Cases 4, 5 and 6).	$U = 1.0$	—
2	All tension members, except HSS, where the tension load is transmitted to some but not all of the cross-sectional elements by fasteners or by longitudinal welds in combination with transverse welds. Alternatively, Case 7 is permitted for W, M, S and HP shapes. (For angles, Case 8 is permitted to be used.)	$U = 1 - \frac{\bar{x}}{l}$	
3	All tension members where the tension load is transmitted only by transverse welds to some but not all of the cross-sectional elements.	$U = 1.0$ and $A_n =$ area of the directly connected elements	—



L1.35

Table D3.1 continued

4 ^(a)	Plates, angles, channels with welds at heels, tees, and W-shapes with connected elements, where the tension load is transmitted by longitudinal welds only. See Case 2 for definition of \bar{x} .	$U = \frac{3l^2}{3l^2 + w^2} \left(1 - \frac{\bar{x}}{l}\right)$	
5	Round HSS with a single concentric gusset plate through slots in the HSS.	$l \geq 1.3D, U = 1.0$ $D \leq l < 1.3D, U = 1 - \frac{\bar{x}}{l}$ $\bar{x} = \frac{D}{\pi}$	
6	Rectangular HSS, with a single concentric gusset plate	$l \geq H, U = 1 - \frac{\bar{x}}{l}$ $\bar{x} = \frac{B^2 + 2BH}{4(B+H)}$	
	with two side gusset plates	$l \geq H, U = 1 - \frac{\bar{x}}{l}$ $\bar{x} = \frac{B^2}{4(B+H)}$	



L1.36

Table D3.1 continued

			$\bar{x} = (e + r)$	
7	W, M, S- or HP- shapes, or tees cut from these shapes. (If U is calculated per Case 2, the larger value is permitted to be used.)	with flange connected with three or more fasteners per line in the direction of loading	$b_f \geq \frac{2}{3}d, U = 0.90$ $b_f < \frac{2}{3}d, U = 0.85$	—
		with web connected with four or more fasteners per line in the direction of loading	$U = 0.70$	—
8	Single and double angles. (If U is calculated per Case 2, the larger value is permitted to be used.)	with four or more fasteners per line in the direction of loading	$U = 0.80$	—
		with three fasteners per line in the direction of loading (with fewer than three fasteners per line in the direction of loading, use Case 2)	$U = 0.60$	—

b = overall width of rectangular HSS member, measured 90° to the plane of the connection, in. (mm); D = outside diameter of round HSS, in. (mm); H = overall height of rectangular HSS member, measured in the plane of the connection, in. (mm); d = depth of section, in. (mm), for tees, d = depth of the section from which the tee was cut, in. (mm); l = length of connection, in. (mm); w = width of plate, in. (mm); e = eccentricity of connection, in. (mm).
* $\bar{x} = \frac{l_1 + l_2}{2}$, where l_1 and l_2 shall not be less than 4 times the weld size.



L1.37

D3. Effective Net Area, A_e

- Lower bound, for a single bolt or when sufficient information is not available to more accurately calculate U .

“For open cross-sections such as W, M, S, C, or HP shapes, WT’s, ST’s and single and double angles; the shear lag factor, U , need not be less than the ratio of the gross area of the connected element(s) to the member gross area.”



L1.38

Example 1

- Determine the available tensile strength
 - 2 - L3 x 3 x 1/2 x 10'-0", $A_g = 5.52 \text{ in.}^2$
 - A36 ($F_y = 36 \text{ ksi}$)
 - 4 -7/8 in. A325-N bolts spaced at 3.0 in.
 - $\bar{x} = 0.929 \text{ in.}$

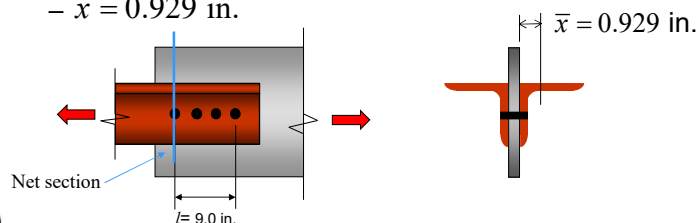

L1.39

Example 1

- Net area
 - 2 angles, one hole in each angle

$$A_n = A_g - 2 \text{ holes}$$

$$= 5.52 - 2[(7/8 + 1/8)(1/2)] = 4.52 \text{ in.}^2$$



L1.40

Example 1

- Shear lag factor

– Case 2 $U = 1 - \frac{\bar{x}}{l} = 1 - \frac{0.929}{9} = 0.90$ ★

– Case 8 $U = 0.8$

– Minimum U
 $U = \frac{3(0.5)}{2.76} = 0.543$



L1.41

Example 1

- Effective net area

$$A_e = A_n U \quad (D3-1)$$

$$= 4.52(0.90) = 4.07 \text{ in.}^2$$



L1.42

Example 1

- Yielding

$$P_n = (F_y A_g) \quad (D2-1)$$

$$= (36)(5.52) = 199 \text{ kips}$$

- Rupture

$$P_n = (F_u A_e) \quad (D2-2)$$

$$= (58)(4.07) = 236 \text{ kips}$$



L1.43

Example 1

- ASD

- Yielding

$$\frac{P_n}{\Omega} = \frac{199}{1.67} = 119 \text{ kips}$$

- Rupture

$$\frac{P_n}{\Omega} = \frac{236}{2.00} = 118 \text{ kips} \quad \star$$

Bolt limit states: 130 kips



L1.44

Example 1

- LRFD
 - Yielding

$$\phi_t P_n = 0.90(199) = 179 \text{ kips}$$

- Rupture

$$\phi_t P_n = 0.75(236) = 177 \text{ kips} \quad \star$$

Bolt limit states: 195 kips

The same limit state controls for ASD and LRFD



L1.45

Example 1

Yielding

For ASD
 $2(59.5) = 119 \text{ kips}$

For LRFD
 $2(89.4) = 179 \text{ kips}$

Just as we have determined

Table 5-2 (continued)
Available Strength in Axial Tension
Angles

$F_y = 36 \text{ ksi}$
 $F_u = 58 \text{ ksi}$

L3/2-L2/2

Shape	Gross Area, A_g		Yielding		Rupture		
	in. ²	in. ²	kips		kips		
			$P_u/1.2$	$\phi_t P_n$	$P_u/1.2$	$\phi_t P_n$	
L3/2x3x1/2			ASD	LRFD	ASD	LRFD	
	x7/8	3.02	2.27	65.1	97.8	65.8	98.7
	x7/8	2.67	2.00	57.6	86.5	58.0	87.0
	x3/4	2.32	1.74	50.0	75.2	50.5	75.7
	x3/8	1.95	1.46	42.0	63.2	42.3	63.5
x1/4	1.58	1.19	34.1	51.2	34.5	51.8	
L3/2x2 1/2x1/2	x7/8	2.77	2.08	59.7	89.7	60.3	90.5
	x3/4	2.12	1.59	45.7	68.7	46.1	69.2
	x3/8	1.79	1.34	38.6	58.0	38.9	58.3
	x1/4	1.45	1.09	31.3	47.0	31.6	47.4
	L3x3x1/2	2.76	2.07	59.5	89.4	60.0	90.0
x7/8	2.43	1.82	52.4	78.7	52.8	79.2	
x3/4	2.11	1.58	45.5	68.4	45.8	68.7	
x3/8	1.78	1.34	38.4	57.7	38.9	58.3	
x1/4	1.44	1.08	31.0	46.7	31.3	47.0	
x3/8	1.09	0.818	23.5	35.3	23.7	35.6	



L1.46

Example 1

Note that
 $A_e = 0.75A_g$

Rupture

$$\frac{A_e}{A_g} = \frac{4.07}{5.52} = 0.737$$

For ASD

$$2 \left(\frac{0.737}{0.75} \right) (60.0) = 118 \text{ kips}$$

For LRFD

$$2 \left(\frac{0.737}{0.75} \right) (90.0) = 177 \text{ kips}$$

Table 5-2 (continued)
Available Strength in Axial Tension
Angles

$F_y = 36 \text{ ksi}$
 $F_u = 58 \text{ ksi}$

L3/2-L2/2

Shape	Gross Area, A_g		Yielding		Rupture		
	in. ²	in. ²	kips		kips		
			$P_u/1.2$	$\phi_t P_n$	$P_u/1.2$	$\phi_t P_n$	
L3/2x3x1/2			ASD	LRFD	ASD	LRFD	
	x7/8	3.02	2.27	65.1	97.8	65.8	98.7
	x7/8	2.67	2.00	57.6	86.5	58.0	87.0
	x3/4	2.32	1.74	50.0	75.2	50.5	75.7
	x3/8	1.95	1.46	42.0	63.2	42.3	63.5
x1/4	1.58	1.19	34.1	51.2	34.5	51.8	
L3/2x2 1/2x1/2	x7/8	2.77	2.08	59.7	89.7	60.3	90.5
	x3/4	2.12	1.59	45.7	68.7	46.1	69.2
	x3/8	1.79	1.34	38.6	58.0	38.9	58.3
	x1/4	1.45	1.09	31.3	47.0	31.6	47.4
	L3x3x1/2	2.76	2.07	59.5	89.4	60.0	90.0
x7/8	2.43	1.82	52.4	78.7	52.8	79.2	
x3/4	2.11	1.58	45.5	68.4	45.8	68.7	
x3/8	1.78	1.34	38.4	57.7	38.9	58.3	
x1/4	1.44	1.08	31.0	46.7	31.3	47.0	
x3/8	1.09	0.818	23.5	35.3	23.7	35.6	



L1.47

Example 2

Example 1 with only one bolt as in a kicker

- 2 - L3 x 3 x 1/2 x 10'-0", $A_g = 5.52 \text{ in.}^2$
- A36 ($F_y = 36 \text{ ksi}$)
- 1 -7/8 in. A325-N bolt
- $\bar{x} = 0.929 \text{ in.}$

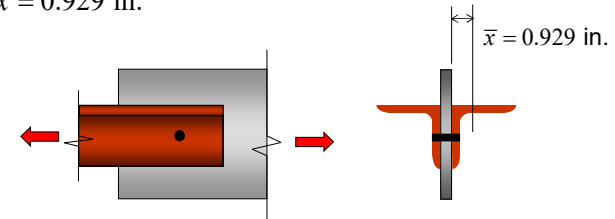

L1.48

Example 2

- Net area (Same as Example 1)
 - 2 angles, one hole in each angle

$$\begin{aligned}A_n &= A_g - 2 \text{ holes} \\ &= 5.52 - 2[(7/8 + 1/8)(1/2)] = 4.52 \text{ in.}^2\end{aligned}$$



L1.49

Example 2

- Shear lag factor
 - Minimum U is the only applicable criteria

$$U = \frac{3(0.5)}{2.76} = 0.543$$



L1.50

Example 2

- Effective net area

$$\begin{aligned}A_e &= A_n U \\ &= 4.52(0.543) = 2.45 \text{ in.}^2\end{aligned}$$

$$\frac{A_e}{A_g} = \frac{2.45}{5.52} = 0.444$$



L1.51

Example 2

- Yielding (Same as Example 1)

$$\begin{aligned}P_n &= F_y A_g && \text{(D2-1)} \\ &= (36)(5.52) = 199 \text{ kips}\end{aligned}$$

- Rupture

$$\begin{aligned}P_n &= F_u A_e && \text{(D2-2)} \\ &= (58)(2.45) = 142 \text{ kips}\end{aligned}$$



L1.52

Example 2

- ASD

- Yielding

$$\frac{P_n}{\Omega} = \frac{199}{1.67} = 119 \text{ kips}$$

- Rupture

$$\frac{P_n}{\Omega} = \frac{142}{2.00} = 71.0 \text{ kips} \star$$

Was 118 kips in Example 1.
Single bolt shear = 32.5 kips



L1.53

Example 2

- LRFD

- Yielding

$$\phi_t P_n = 0.90(199) = 179 \text{ kips}$$

- Rupture

$$\phi_t P_n = 0.75(142) = 107 \text{ kips} \star$$

The same limit state controls for ASD and LRFD

Was 177 kips in Example 1.
Single bolt shear = 48.7 kips



L1.54

Example 3

- Determine the available strength of the W10x19, A992 tension member spliced at the web as shown with 3/4 in. A325N bolts.

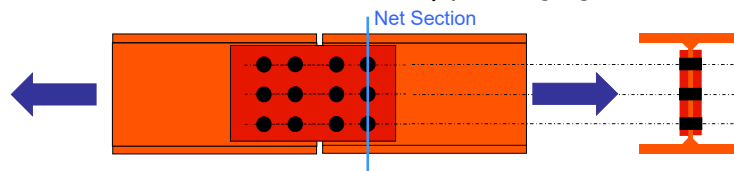

At the net section we are going to deduct for three bolt holes to get the net area. To get the effective net area we must account for the fact that the flanges are not connected



L1.55

Example 3

- Shear Lag Factor for a W attached only at web

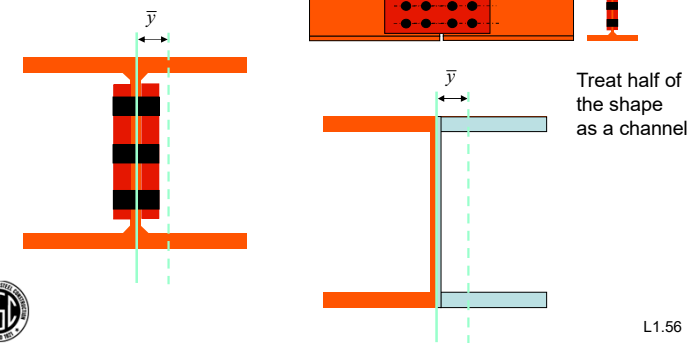

Treat half of the shape as a channel



L1.56

Example 3

- W10x19

$$A_g = 5.62 \text{ in.}^2$$

$$d = 10.2 \text{ in.}$$

$$t_w = 0.25 \text{ in.}$$

$$b_f = 4.02 \text{ in.}$$

$$t_f = 0.395 \text{ in.}$$

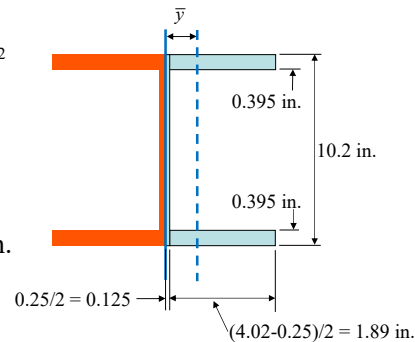

L1.57

Example 3

- W10x19

$$A_{\text{Channel}} = 2(1.89(0.395)) + 10.2(0.125)$$

$$= 2(0.747) + 1.28$$

$$= 2.77 \text{ in.}^2$$

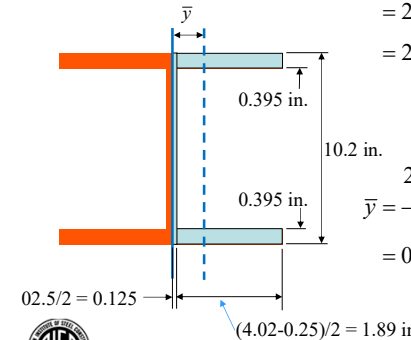

$$\bar{y} = \frac{2(0.747)\left(0.125 + \frac{1.89}{2}\right) + 1.28\left(\frac{0.125}{2}\right)}{2.77}$$

$$= 0.606 \text{ in.}$$



L1.58

Example 3

- W10x19

– Gross area given $A_g = 5.62 \text{ in.}^2$

– Net area

$$A_n = 5.62 - 3\left(\frac{3}{4} + \frac{1}{16} + \frac{1}{16}\right)(0.25) = 4.96 \text{ in.}^2$$

– Effective net area $U = 1 - \frac{\bar{x}}{l} = 1 - \frac{0.606}{3.0} = 0.80$

$$A_e = UA_n = 0.8(4.96) = 3.97 \text{ in.}^2$$



L1.59

Example 3

- Yielding

$$P_n = F_y A_g \quad (\text{D2-1})$$

$$= (50)(5.62) = 281 \text{ kips}$$

- Rupture

$$P_n = F_u A_e \quad (\text{D2-2})$$

$$= (65)(3.97) = 258 \text{ kips}$$



L1.60

Example 3

- ASD
 - Yielding

$$\frac{P_n}{\Omega} = \frac{281}{1.67} = 168 \text{ kips}$$

- Rupture

$$\frac{P_n}{\Omega} = \frac{258}{2.00} = 129 \text{ kips} \star$$

Six bolts = 143 kips



L1.61

Example 3

- LRFD
 - Yielding

$$\phi_t P_n = 0.90(281) = 253 \text{ kips}$$

- Rupture

$$\phi_t P_n = 0.75(258) = 194 \text{ kips} \star$$

The same limit state controls for ASD and LRFD

Six bolts = 215 kips



L1.62

Example 3

Note that $A_e = 0.75A_g$

$$\frac{A_e}{A_g} = \frac{3.97}{5.62} = 0.706$$

Rupture

For ASD

$$\left(\frac{0.706}{0.75}\right)(137) = 129 \text{ kips}$$

For LRFD

$$\left(\frac{0.706}{0.75}\right)(206) = 194 \text{ kips}$$

Table 5-1 (continued)
Available Strength in Axial Tension
W-Shapes

Shape	Gross Area, A_g		Yielding				Rupture			
	$A_e = 0.75A_g$		kips		kips		kips		kips	
	in. ²	in. ²	ASD	LRFD	ASD	LRFD	ASD	LRFD	ASD	LRFD
W10x112	32.9	24.7	940	1400	603	1005				
x100	29.3	22.0	877	1320	715	1070				
x90	26.6	19.5	770	1170	624	951				
x77	22.7	17.0	650	1020	553	829				
x68	19.9	14.9	590	896	494	726				
x60	17.7	13.3	530	787	432	648				
x54	15.8	11.9	473	711	387	580				
x49	14.4	10.8	431	648	351	527				
W10x45	13.3	9.98	398	599	324	487				
x39	11.5	8.63	344	518	290	421				
x33	9.71	7.28	291	437	237	353				
W10x30	8.84	6.63	265	398	215	323				
x26	7.61	5.71	229	342	186	279				
x22	6.49	4.87	194	292	158	237				
W10x19	5.62	4.22	169	251	137	206				
x17	4.99	3.74	149	225	122	182				
x15	4.41	3.31	132	198	108	161				
x12	3.54	2.66	106	159	86.5	130				



L1.63

Manual Tables

- Note that when $A_e = 0.75A_g$, rupture controls for A992 and yield for A36.

Table 5-1 (continued)
Available Strength in Axial Tension
W-Shapes

Shape	Gross Area, A_g		Yielding				Rupture			
	$A_e = 0.75A_g$		kips		kips		kips		kips	
	in. ²	in. ²	ASD	LRFD	ASD	LRFD	ASD	LRFD	ASD	LRFD
W10x112	32.9	24.7	905	1400	601	1000				
x100	29.3	22.0	837	1301	715	1070				
x90	26.6	19.5	770	1170	624	951				
x77	22.7	17.0	680	1020	553	829				
x68	19.9	14.9	606	908	494	726				
x60	17.7	13.3	539	797	432	648				
x54	15.8	11.9	473	711	387	580				
x49	14.4	10.8	431	648	351	527				
W10x45	13.3	9.98	398	599	324	487				
x39	11.5	8.63	344	518	290	421				
x33	9.71	7.28	291	437	237	353				
W10x30	8.84	6.63	265	398	215	323				
x26	7.61	5.71	229	342	186	279				
x22	6.49	4.87	194	292	158	237				
W10x19	5.62	4.22	169	251	137	206				
x17	4.99	3.74	149	225	122	182				
x15	4.41	3.31	132	198	108	161				
x12	3.54	2.66	106	159	86.5	130				



L1.64

Table 5-2 (continued)
Available Strength in Axial Tension
Angles

Shape	Gross Area, A_g		Yielding				Rupture			
	$A_e = 0.75A_g$		kips		kips		kips		kips	
	in. ²	in. ²	ASD	LRFD	ASD	LRFD	ASD	LRFD	ASD	LRFD
L3/2x3x1/2	3.02	2.27	65.1	97.8	60.8	90.7				
x1/2	2.87	2.08	62.6	93.9	58.0	87.0				
x3/4	2.32	1.74	50.0	75.2	50.5	75.7				
x1	1.98	1.46	42.0	63.2	42.3	63.5				
x1 1/4	1.58	1.19	34.1	51.2	34.5	51.8				
L3/2x2 1/2x1/2	2.77	2.08	59.7	89.7	60.3	90.5				
x1/2	2.12	1.59	45.7	68.7	46.1	68.2				
x3/4	1.79	1.34	38.6	58.0	38.9	58.3				
x1	1.45	1.09	31.3	47.0	31.6	47.4				
L3x3x1/2	2.76	2.07	59.5	89.4	60.0	90.0				
x1/2	2.43	1.82	52.4	79.7	52.8	79.2				



Example 4

- Design a diagonal tension brace as shown.

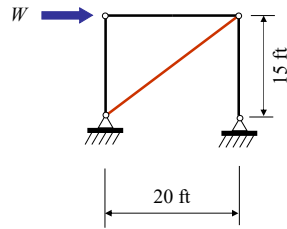

Use a single angle A36 member
Assume $\frac{3}{4}$ in. A325N bolts

From a first-order determinant analysis, brace force $P = W(25/20)$

Code specified lateral load = 50 kips

For wind load only,

LRFD: $W = 1.0(50) = 50$ kips
ASD: $W = 0.6(50) = 30$ kips



L1.65

Example 4 (LRFD)

- Design a diagonal tension brace as shown.

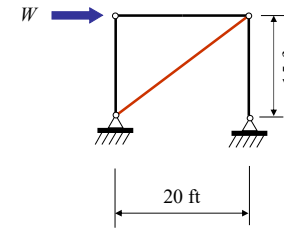

For LRFD, $W = 50$ kips
From a first-order analysis

$$P_r = 50 \left(\frac{25}{20} \right) = 62.5 \text{ kips}$$

Start with the assumption that yielding controls and determine the required area

$$A_g = \frac{P_r}{\phi F_y} = \frac{62.5}{0.9(36)} = 1.93 \text{ in.}^2$$



L1.66

Example 4 (LRFD)

- Design a diagonal tension brace as shown.

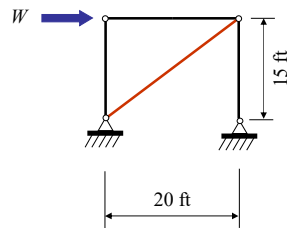

Try a 3x3x3/8 angle, $A_g = 2.11 \text{ in.}^2$

Since this area is greater than required, we know the limit state of yielding has sufficient strength.

Now consider the limit state of rupture

$$\bar{x} = 0.884 \text{ in.}$$

4 - $\frac{3}{4}$ in. A325N bolts will carry 71.6 kips. For a typical spacing of 3 in.,

$$U = 1 - \frac{\bar{x}}{l} = 1 - \frac{0.884}{9.0} = 0.902$$



L1.67

Example 4 (LRFD)

- Design a diagonal tension brace as shown.

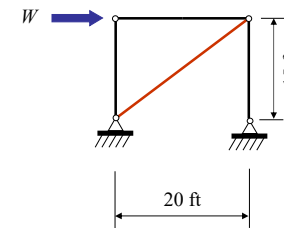

Net area

$$A_n = 2.11 - 1 \left(\frac{3}{4} + \frac{1}{16} + \frac{1}{16} \right) \left(\frac{3}{8} \right) = 1.78 \text{ in.}^2$$

Effective net area

$$A_e = U A_n = 0.902(1.78) = 1.61 \text{ in.}^2$$

Nominal rupture strength

$$P_n = F_u A_e = 58(1.61) = 93.4 \text{ kip}$$

Available rupture strength

$$\phi P_n = 0.75(93.4) = 70.1 \text{ kip}$$



L1.68

Example 4 (LRFD)

- Design a diagonal tension brace as shown.

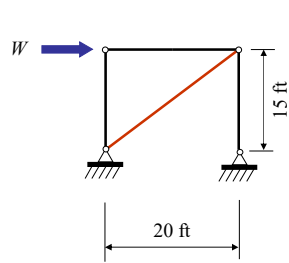

Available yield strength for LRFD
 $\phi P_n = 0.9(36)(2.11) = 68.4 > 62.5$ kips

Available rupture strength
 $\phi P_n = 0.75(93.4) = 70.1 > 62.5$ kips

A 3x3x3/8 A36 angle will work. If more than 4 bolts are required, the shear lag factor will increase so this solution is conservative. If fewer than 4 bolts are needed, the rupture limit state must be rechecked.



L1.69

Example 4 (ASD)

- Design a diagonal tension brace as shown.

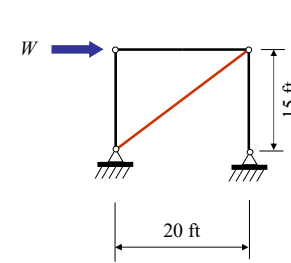

Available yield strength for ASD
 $\frac{P_n}{\Omega} = \frac{(36)(2.11)}{1.67} = 45.5 > 37.5$ kips

Available rupture strength
 $\frac{P_n}{\Omega} = \frac{93.4}{2.00} = 46.7 > 37.5$ kips

A 3x3x3/8 A36 angle will work. If more than 4 bolts are required, the shear lag factor will increase so this solution is conservative. If fewer than 4 bolts are needed, the rupture limit state must be rechecked.

$P_r = 30 \left(\frac{25}{20} \right) = 37.5$ kips



L1.70

Block Shear

J4.3. Block Shear Strength (Another connection issue)

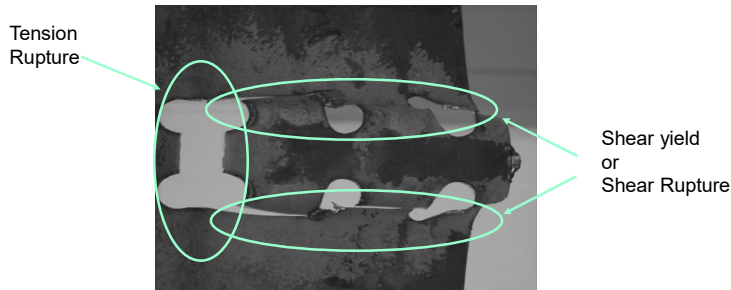

This is actually a connection issue.



L1.71

Block Shear

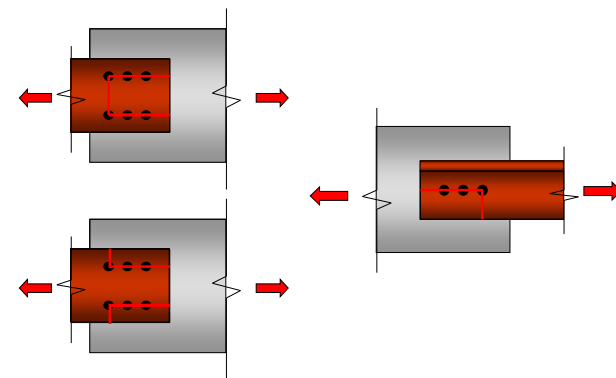

L1.72

Block Shear

- J4.3. Tear out strength based on a combination of limit states

Shear Yield + Tension Rupture

or

Shear Rupture + Tension Rupture



L1.73

Block Shear

- Compute Strength for Tensile Rupture Limit State

$$F_u A_{nt}$$

- Compute Strength for Shear Rupture and Shear Yield Limit States

$$0.6F_u A_{nv} \quad 0.6F_y A_{gv}$$



L1.74

Block Shear

- Always use tension rupture term

$$R_n = 0.6F_u A_{nv} + U_{bs} F_u A_{nt} \quad (\text{J4-5})$$

- Use shear rupture unless shear yield is less, then

$$R_n = 0.6F_y A_{gv} + U_{bs} F_u A_{nt} \quad (\text{J4-5})$$

$$\phi = 0.75 \text{ (LRFD)} \quad \Omega = 2.00 \text{ (ASD)}$$



L1.75

Block Shear Reduction Factor

- For uniform tensile stress

$$R_n = 0.6F_u A_{nv} + U_{bs} F_u A_{nt} \quad (\text{J4-5})$$

$$U_{bs} = 1.0$$

- For nonuniform tensile stress

$$U_{bs} = 0.5$$

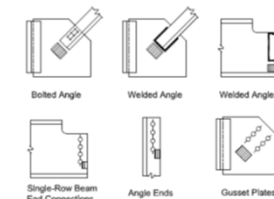

(a) Cases for which $U_{bs} = 1.0$

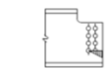

(b) Cases for which $U_{bs} = 0.5$



L1.76

Example 5

Determine the available block shear strength

From Example 1

2 - L3 x 3 x 1/2 A36

4 - 7/8 inch bolts

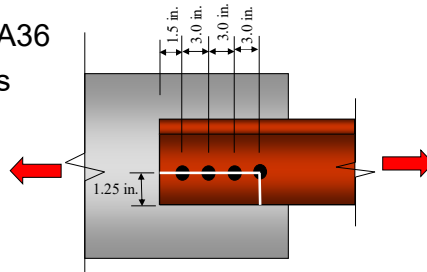

L1.77

Example 5

For one angle, shear areas

$$A_{gv} = 10.5 \left(\frac{1}{2} \right) = 5.25 \text{ in.}^2$$

$$A_{nv} = \left(10.5 - 3.5 \left(\frac{7}{8} + \frac{1}{16} + \frac{1}{16} \right) \right) \left(\frac{1}{2} \right) = 3.50 \text{ in.}^2$$

For one angle, tension area

$$A_{nt} = \left(1.25 - \frac{1}{2} \left(\frac{7}{8} + \frac{1}{16} + \frac{1}{16} \right) \right) \left(\frac{1}{2} \right) = 0.375 \text{ in.}^2$$



L1.78

Example 5

Shear rupture

$$0.6F_u A_{nv} = 0.6(58)(3.50) = 122 \text{ kips}$$

Shear Yield

$$0.6F_y A_{gv} = 0.6(36)(5.25) = 113 \text{ kips} \star$$

Tension rupture

$$F_u A_{nt} = 58(0.375) = 21.8 \text{ kips} \star$$



L1.79

Example 5

Nominal Block Shear Strength for one angle
with $U_{bs} = 1.0$

$$R_n = 0.6F_y A_{gv} + U_{bs} F_u A_{nt} \quad (\text{J4-5})$$

$$R_n = (113 + 1.0(21.8)) = 135 \text{ kips}$$



L1.80

Example 5

Allowable block shear strength for both angles (ASD)

$$\frac{R_n}{\Omega} = 2 \left(\frac{135}{2.0} \right) = 135 \text{ kips}$$



L1.81

Example 5

- Summary ASD
 - Tension on angles from Example 1

$$\frac{P_n}{\Omega} = 118 \text{ kips} \star$$

- Block shear

$$\frac{R_n}{\Omega} = 135 \text{ kips}$$

Thus, block shear does not control

Bolt limit states = 130 kips



L1.82

Example 5

Design block shear strength for both angles (LRFD)

$$\phi R_n = 2(0.75(135)) = 203 \text{ kips}$$



L1.83

Example 5

- Summary LRFD
 - Tension on angles from Example 1

$$\phi P_n = 177 \text{ kips} \star$$

- Block shear

$$\phi R_n = 203 \text{ kips}$$

Again, the same limit state controls

Bolt limit states = 195 kips



L1.84

Example 5

- The Manual includes tables, in Part 9, that may be used to check block shear.
- These tables appear to be for coped beams but may also be used for other block shear situations



L1.85

Example 5

Table 9-3a
Block Shear
Tension Rupture
Component
per inch of thickness, kips/in.

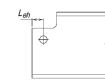

$U_{bs} = 1.0$

L_{bp} , in.	58 ksi Bolt diameter, d, in.					
	$\frac{3}{4}$		$\frac{7}{8}$		1	
	$\frac{F_u A_{nt}}{R_t}$	$\phi F_u A_{nt}$	$\frac{F_u A_{nt}}{R_t}$	$\phi F_u A_{nt}$	$\frac{F_u A_{nt}}{R_t}$	$\phi F_u A_{nt}$
1	ASD 16.3	LRFD 24.5	ASD 14.5	LRFD 21.8	ASD 12.7	LRFD 19.0
1½	19.9	29.9	18.1	27.2	16.3	24.5
1¾	23.6	35.3	21.8	32.6	19.9	29.9
1½	27.2	40.8	25.4	38.1	23.6	35.3
1½	30.8	46.2	29.0	43.5	27.2	40.8
1¾	34.4	51.7	32.6	48.9	30.8	46.2
1¾	38.1	57.1	36.3	54.4	34.4	51.7
1¾	41.7	62.5	39.9	59.8	38.1	57.1
2	45.3	67.9	43.5	65.2	41.7	62.5

- Using Tables
Tension rupture

ASD 21.8 kips/in.
LRFD 32.6 kips/in



L1.86

Example 5



Table 9-3b (continued)
Block Shear
Shear Yielding
Component
per inch of thickness, kips/in.

Table 9-3c (continued)
Block Shear
Shear Rupture
Component
per inch of thickness, kips/in.

L_{bp} , in.	3		4	
	ASD	LRFD	ASD	LRFD
3	182	243	192	256
1½	111	156	125	168
1¾	112	158	127	171
1½	113	170	129	174
1½	115	172	132	177
1¾	116	174	134	180
1½	117	176	136	183
2	119	178	138	186
2¼	121	182	142	191
2½	124	186	147	197
2¾	127	190	151	203
3	130	194	156	210

- Using Tables
Select the smaller value from shear yielding or rupture.

ASD 113 kips/in.
LRFD 170 kips/in.



L1.87

Example 5

- Block shear strength (ASD)

$$\frac{R_n}{\Omega} = (21.8 + 113)(0.5) = 67.4 \text{ kips for one angle.}$$

for both angles,

$$\frac{R_n}{\Omega} = 2(67.4) = 135 \text{ kips}$$

This is the same as what was previously determined



L1.88

Example 5

- Block shear strength (LRFD)

$$\phi R_n = (32.6 + 170)(0.5) = 101 \text{ kips for one angle}$$

for both angles,

$$\phi R_n = 2(101) = 202 \text{ kips}$$

This is essentially the same as what was previously determined



L1.89

Eyebars



D6 Eyebars

D6.1. Tensile Strength

- Yielding on the body of eyebar

$$P_n = F_y A_g \quad (D2-1)$$

D6.2. Dimensional Requirements

- Establish proportions so that yielding of the body is the only limit state to be checked.
- Requirements (a) through (f).



L1.90

Eyebars

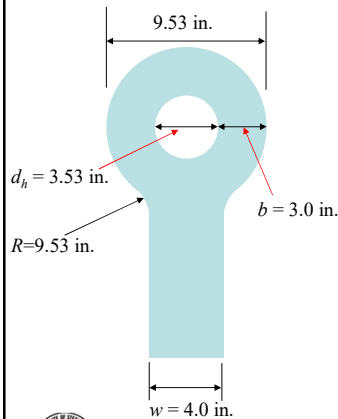

Determine the available strength of a $\frac{1}{2}$ in. by 4.0 in. eyebar with a 3.5 in. pin. First check the dimensional requirements of Section D6.2.

$$t \geq \frac{1}{2} \text{ in.} = 0.5 \text{ in.}$$

$$w \leq 8t = 8(0.5) = 4.0 \text{ in.}$$

$$d \geq \frac{7}{8} w = \frac{7}{8}(4.0) = 3.5 \text{ in.}$$

$$d_h \leq d + \frac{1}{32} \text{ in.} = 3.5 + \frac{1}{32} = 3.53 \text{ in.}$$

$$R \geq 2b + d_h = 2(3.0) + 3.53 = 9.53 \text{ in.}$$

$$\frac{2}{3} w \leq b \leq \frac{3}{4} w$$

$$\frac{2}{3}(4.0) \leq 3.0 \leq \frac{3}{4}(4.0)$$



L1.91

Eyebars

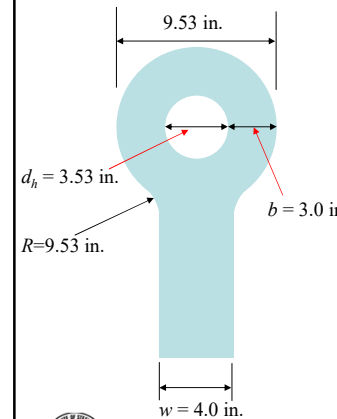

Determine the available strength of a $\frac{1}{2}$ in. by 4.0 in. eyebar with a 3.5 in. pin. First check the dimensional requirements of Section D6.2.

The dimensional criteria of Section D6.2 are satisfied.

$$P_n = 36 \left(\frac{1}{2} \right) (4.0) = 72.0 \text{ kips}$$

For LRFD

$$\phi P_n = 0.9(72.0) = 64.8 \text{ kips}$$

For ASD

$$\frac{P_n}{\Omega} = \frac{72.0}{1.67} = 43.1 \text{ kips}$$



L1.92

Pin Connected Members



D5 Pin Connected Members

D5.1. Tensile Strength

- Tensile rupture on effective net area
- Shear rupture on effective area
- Yielding on the gross section
- Bearing on the projected area of pin

D5.2. Dimensional Requirements

- Requirements (a) through (d).



L1.93

Pin Connected Members

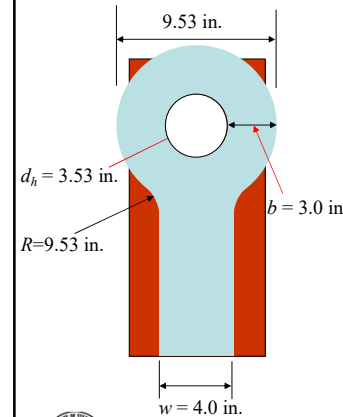

Compare a pin connected member that uses the same size pin as the eyebar just considered. Assume a 1/2 in. thick plate.

Check the dimensional requirements in Section D5.

$$d = 3.5 \text{ in.}$$

$$t = 0.5 \text{ in.}$$

$$d_h \leq d + \frac{1}{32} = 3.53 \text{ in.}$$

$$b_e = 2t + 0.63 \text{ in.} = 2(0.5) + 0.63 = 1.63 \text{ in.} \leq b$$

$$w \geq 2b_e + d = 2(1.625) + 3.5 = 6.75 \text{ in.}$$

$$a \geq 1.33b_e = 1.33(1.625) = 2.16 \text{ in.}$$



L1.94

Pin Connected Members

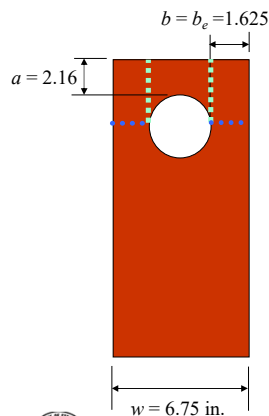

Compare a pin connected member that uses the same size pin as the eyebar just considered. Assume a 1/2 in. thick plate.

The dimensional requirements are satisfied.

- Tensile rupture limit state (Eq. D5-1)

$$P_n = F_u (2tb_e) = 58(2(0.5)(1.63)) = 94.5 \text{ kips}$$

$$\phi P_n = 0.75(94.5) = 70.9 \text{ kips}$$

- Shear rupture limit state (Eq. D5-2)

$$P_n = 0.6F_u \left(2t \left(a + \frac{d}{2} \right) \right) = 0.6(58) \left(2(0.5) \left(2.16 + \frac{3.5}{2} \right) \right) = 136 \text{ kips}$$

$$\phi P_n = 0.75(136) = 102 \text{ kips}$$



L1.95

Pin Connected Members

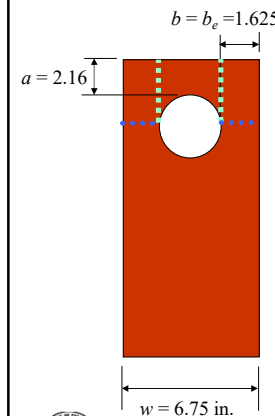

Compare a pin connected member that uses the same size pin as the eyebar just considered. Assume a 1/2 in. thick plate.

The dimensional requirements are satisfied.

- Bearing on projected area of pin (Eq. J7-1)

$$R_n = 1.8F_y A_{pb} = 1.8(36)(0.5)(3.5) = 113 \text{ kips}$$

$$\phi R_n = 0.75(113) = 85.1 \text{ kips}$$

- Yield on the gross section (Eq. D2-1)

$$R_n = F_y A_g = (36)(0.5)(6.75) = 122 \text{ kips}$$

$$\phi R_n = 0.9(122) = 110 \text{ kips}$$



L1.96

Pin Connected Members

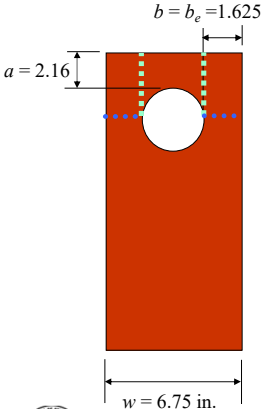

Compare a pin connected member that uses the same size pin as the eyebar just considered. Assume a 1/2 in. thick plate.

The dimensional requirements are satisfied.

Tensile rupture is the controlling limit state.

For LRFD
 $\phi R_n = 0.75(94.5) = 70.9$ kips

For ASD
 $\frac{R_n}{\Omega} = \frac{94.5}{2.00} = 47.3$ kips



L1.97

Pin Connected Members

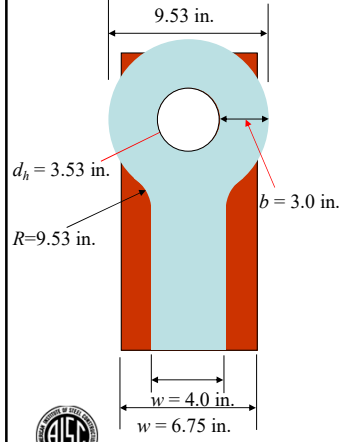

Compare the strengths of the designed eyebar and pin connected member

Eyebar (Yield)
 $\phi P_n = 0.9(72.0) = 64.8$ kips

$\frac{P_n}{\Omega} = \frac{72.0}{1.67} = 43.1$ kips

Pin Connected Member (Tensile rupture)
 $\phi R_n = 0.75(94.5) = 70.9$ kips

$\frac{R_n}{\Omega} = \frac{94.5}{2.00} = 47.3$ kips



L1.98

Summary

- Looked at the limit states for tension members
- Addressed the required area calculations
- Compared hand calculations to the use of Manual tables
- Considered block shear limit state
- Designed an eyebar and a pin connected member



L1.99

Lesson L2

- The next lesson will look at the principles of design for compression members.
- We will look primarily at the material in Chapter E of the Specification
- We will also look at Part 4 of the Manual



L1.100



Thank You

American Institute of Steel Construction
130 East Randolph St., Suite 2000
Chicago, IL 60601



L1.101

Single-Session Registrants

CEU / PDH Certificates

- You will receive an email on how to report attendance from: registration@aisc.org.
- Be on the lookout: Check your spam filter! Check your junk folder!
- Completely fill out online form. Don't forget to check the boxes next to each attendee's name!



Smarter.
Stronger.
Steel.

Single-Session Registrants

CEU / PDH Certificates

- Reporting site (URL will be provided in the forthcoming email).
- Username: Same as AISC website username.
- Password: Same as AISC website password.



Smarter.
Stronger.
Steel.

Course Package Registrants

CEU / PDH Certificates

One certificate will be issued at the conclusion of the course.



Smarter.
Stronger.
Steel.



Course Package Registrants

Attendance and PDH Certificates

- You have two options to receive credit for a given session.
 - Option 1: Watch the live session. Credit for live attendance will be displayed on the Course Resources table within two days of the session.
 - Option 2: Watch the recording and pass the associated quiz.

Videos and Quizzes

- For each session, find access within two business days after the live air date. (An email will be sent from webinars@aisc.org.)
- Quiz scores are displayed in the Course Resources table.

Distribution of Certificates

All certificates will be issued after the course is completed. Only the registrant will receive a certificate for the course.



Course Package Registrants

Course Resources

Find all your handouts, quizzes and quiz scores, recording access, and attendance information in one place!



Course Package Registrants

Course Resources

Go to www.aisc.org and sign in.

Course Package Registrants

Course Resources

Go to www.aisc.org and sign in.



Course Package Registrants

Course Resources



EDUCATION PUBLICATIONS AWARDS AND COMPETITIONS TECHNICAL RESOURCES STEEL SOLUTIONS CENTER



AISC » MY ACCOUNT » COURSE RESOURCES

Course Resources

Event	Start Date
Seismic Design of Steel	1/13/2019 12:00:00 AM
8-Session Design of Facade Attachments	5/6/2019 1:00:00 PM
NS 23.8-Session: Night School 13: Fundamentals of Connection Design	10/23/17 7:00:00 PM
NS 25.8-Session: Night School 16: Seismic Design of Steel	1/9/2018 7:00:00 PM
NS 27.8-Session: Night School 17: Design of Facade Attachments	7/18/2018 7:00:00 PM
NS 28.8-Session: Night School 18: Steel Construction: M4 To Through Out	10/15/2018 7:00:00 PM
NS 28.8-Session: Night School 19: Connection Design	2/4/2019 7:00:00 PM
NS 20.8-Session: Night School 20: Classical Methods of Structural Analysis	6/9/2018 7:00:00 PM
8-Session: Seismic Design of Steel - Concrete & Steel	7/16/2018 1:00:00 PM

Course Package Registrants

Course Resources



EDUCATION PUBLICATIONS AWARDS AND COMPETITIONS TECHNICAL RESOURCES STEEL SOLUTIONS CENTER



AISC » MY ACCOUNT » COURSE RESOURCES » DESIGN OF FACADE ATTACHMENTS » COURSE RESOURCES

Design of Facade Attachments

4-SESSION PACKAGE RESOURCES

Event	Date	Handout	Video	Quiz	Attendance
F2: Facade Fundamentals	N/A	Checklist	Video Facade AZ10375	Pass Score 100	Not
L1: Facade Attachments Part 1	May 9 2019 1:00PM EDT	Checklist	Available 05/11/2019 5:00PM EDT	Available 05/11/2019 5:00 PM EDT	Pending
L2: Facade Attachments Part 2	May 16 2019 1:00PM EDT	Checklist	Available 05/16/2019 5:00PM EDT	Available 05/16/2019 5:00 PM EDT	Pending
L3: Facade Attachments - Building Lateral Drift	May 23 2019 1:00PM EDT	Checklist	Available 05/29/2019 5:00PM EDT	Available 05/29/2019 5:00 PM EDT	Pending
Final Exam	N/A			Available 5/27/2019 5:00 PM EDT	



AISC | Thank you.

