

### AISC Live Webinars

Thank you for joining our live webinar today.  
We will begin shortly. Please standby.

Basics of Steel Railway Bridge Engineering  
June 15, 2021



### AISC Live Webinars

**Today's live webinar will begin shortly. Please stand by.**

Today's audio will be broadcast through the internet. Please be sure to turn up the volume on your speakers.

Please type any questions or comments in the Q&A window.



### AISC Live Webinars

#### AIA Credit

AISC is a Registered Provider with The American Institute of Architects Continuing Education Systems (AIA/CES). Credit(s) earned on completion of this program will be reported to AIA/CES for AIA members. Certificates of Completion for both AIA members and non-AIA members are available upon request.

This program is registered with AIA/CES for continuing professional education. As such, it does not include content that may be deemed or construed to be an approval or endorsement by the AIA of any material of construction or any method or manner of handling, using, distributing, or dealing in any material or product.

Questions related to specific materials, methods, and services will be addressed at the conclusion of this presentation.



### AISC Live Webinars

#### Copyright Materials

This presentation is protected by US and International Copyright laws. Reproduction, distribution, display and use of the presentation without written permission of AISC is prohibited.

© The American Institute of Steel Construction 2021

The information presented herein is based on recognized engineering principles and is for general information only. While it is believed to be accurate, this information should not be applied to any specific application without competent professional examination and verification by a licensed professional engineer. Anyone making use of this information assumes all liability arising from such use.



## AISC Live Webinars

---

### Course Description

Basics of Steel Railway Bridge Engineering  
June 15, 2021

This webinar will review the basics of design for steel bridges used in railway applications. Attendees will obtain a basic understanding of the behavior, AREMA Manual provisions, structural member design, and unique loading criteria associated with such bridges.



**Smarter.  
Stronger.  
Steel.**

## AISC Live Webinars

---

### Learning Objectives

- Explain why deflections tend to govern the design of steel railway bridges and how that fact can be used to initiate a design.
- List the guidelines for determining camber for steel railway bridges of various lengths.
- Describe the purpose of a fracture control plan and list several reasons why designers tend to over-specify fracture critical members.
- Identify what should be considered when specifying welds for built-up plate girders for bridges. Identify locations where complete-joint penetration groove welds are inappropriate for design.



**Smarter.  
Stronger.  
Steel.**

## Basics of Steel Railway Bridge Engineering



Robert Connor, PhD  
Jack and Kay Hockema Professor of Civil Engineering  
Purdue University



Stephen Dick, SE, PhD  
Senior Research Engineer  
Purdue University Bowen Laboratory



**Smarter.  
Stronger.  
Steel.**

## Part 1 - Basics

### Environment, Design Basics



8



### Environment, existing bridges

- A railroad bridge performs the same essential function as a highway bridge
- The inventory of steel railroad bridges is generally “old”
  - 70% are at least 80 years old
  - 50% are at least 100 years old
  - ~2% are at least 120 years old (1900)
- Still generally functional although fatigue may be an issue.
  - Not yet for deck girders.
  - Floor systems and truss floor beam hangers are susceptible to fatigue.
- Age is not an appropriate response for replacement.



9

### Environment, current loads

- **Applicable to freight rail, heavy rail commuter, standard passenger**
- Heavy train conditions  $\geq 50$  trains per day per main line track
- Train lengths – up to 10,000 feet are common
  - Increases in lengths are planned for some railroads
- Train weights – 15,000 to 20,000 tons for bulk commodity trains, passenger trains: 500 -1,000 tons
- Number of cars – unit trains: 60 – 200 cars  
manifest (mixed) trains: 100 – 200 cars



10

### Environment, current loads

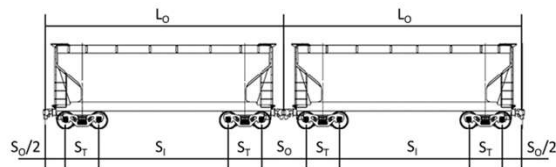

From AREMA MRE Chapter 15, Figure 15-9-11

- Gross Rail Load (GRL) - 286,000 lbs on 4 axles
- Minimum length of ~42 feet ( $L_0$ ), ~6830 plf (max)



11

### Environment, loading wheelbase

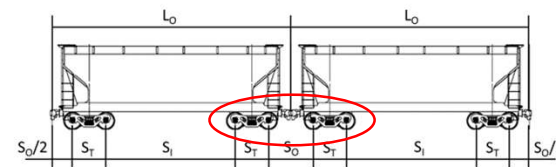

From AREMA MRE Chapter 15, Figure 15-9-11

- Minimum – two 70” trucks plus 81” coupler length, 221”, 71.5 kips per axle
- Locomotives – six-axle wheelbase, ~480”, 72.0 kips per axle



12

**Environment, clearances**

- Required to comply with clearances for trusses and through girders
- Height is in the range of 23'-0" (or higher) for double-stack container operations

Figure 28-1-2. Railway Bridges

13

**Environment, highway versus railroad**

**Highway Bridges**

- Economy of section with continuous spans
- Different measures for protection of bridge elements
  - i.e., integral abutments, salt protection measures

**Railway Bridges**

- Simple spans are simpler and faster to maintain and replace
- Reduction of maintenance and construction time “Time is money”
- Exposed elements easier to inspect – “No bridge art”
- Form follows function

14

**Environment, highway versus railroad**

**Highway Bridges**

- Designed for application of wheel loads anywhere on the deck
- Minimum inspection frequency is once every two years

**Railway Bridges**

- The load path(s) on the bridge is defined and constant
- Minimum inspection frequency is once every year

15

**Environment, bridge replacement**

- Railroads basically invented “Accelerated Bridge Construction”
- Replacement is planned around operations on existing lines
- Design requires consideration of how the bridge is replaced

16

### Environment, bridge replacement

- Potential bridge replacement by rail access only
- Remote access
- Sensitive areas



17

### Design Basics, design recommendations

American Railway Engineering and Maintenance-of-way Association (AREMA)  
Manual for Railway Engineering (MRE), 2021 Edition, updated annually.

- **Chapter 15 – Steel Structures**
- Chapter 8 – Concrete Structures and Foundations
- Chapter 7 – Timber Structures
- Chapter 9 – Seismic Design (if needed)
- Above are recommendations only, not specifications. The Owner may also supply specific details and guidelines to follow.



18

### Design Basics

#### FROM THE FOREWORD OF CHAPTER 15

- Standard gage track (4 feet 8.5 inches, 1435 mm)
- Length up to 400 feet
- North American freight and passenger equipment
- Speeds of 80 mph for freight trains and 90 mph for passenger trains\*
- Focus on freight rail, heavy rail commuter, and standard passenger\*



19

### Design Basics, useful lengths

#### ARTICLE 1.2.3 TYPES OF BRIDGES

- **Beam Span:** up to ~70 feet with modern beam sizes
- **Deck girder:**
  - Two or three girders per track:  $L \leq 150$  feet
  - Four or more girders per track:  $L \leq 200$  feet
- **Through girder:**  $L \leq 150$  feet
- **Through or deck truss:**  $L > 150$  feet
- Limit for girder length is available width of plate for the web (longitudinal splicing of webs not usually done)



20

### Design Basics, types of decks

**Walkways:** Usually required today. Not shown in these drawings. Details available from the Owner. Designs also need to consider inspection; both access and safety.

**Open decks:** Generally a timber deck (timber, glu-lam, composites)

- Bridge ties are larger than standard cross ties
- Bridge ties serve as cross ties for the rails
- Reduced dead load

**Ballast decks:** Solid floor allowing use of roadway ballast for track

- Timber, concrete (composite or non-composite), steel
- Increased dead load but simpler track maintenance



21

### Design Basics, open decks

- Full Live Load Impact
- Decreased DL/Increased LL capacity for same section
- Bridge approach track quality needs to be maintained
- Welded rail expansion/contraction can cause track and deck issues (expansion joints)

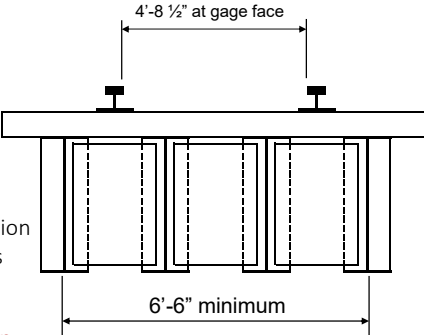

**Beam (or Girder) Span**



22

### Design Basics, ballast decks

- Reduced LL Impact (90%)
- Simpler track maintenance
- Better approach track quality
- Increased Dead Load
- Ballast depth creep
- Reduced LL capacity

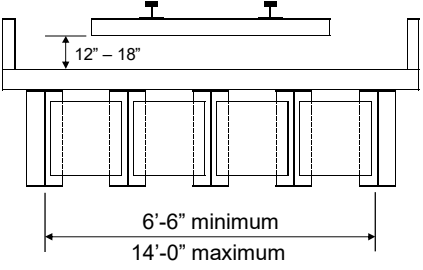

**Beam (or Girder) Span**



23

### Design Basics, ballast decks

- Concrete and steel decks are usually waterproofed
- Positive drainage required on some projects

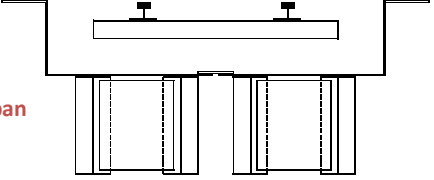

**Two-piece beam/girder span with steel deck**



24

### Design Basics, beam spans

**Multiple beam span**

- Common under multiple tracks
- Common for road underpass
- Short spans can use "S" shapes
- Common short spans
- Check deflection for short beams

25

### Design Basics, floor systems

- Four-beam open deck shown
- Typical of floor systems for stringers and floorbeams in trusses and through girders
- Independent support for each rail
- Can be open or ballast deck
- Timber concrete, or steel deck

**Short beam span or floor system for trusses and through girders**

26

### Design Basics, basic deck girders

- Standard type of railroad bridge
- 1/3 of all railroad bridges
- Still viable as a replacement
- Four girder spans also used
- Timber and concrete ballast decks for two girders

**Two-girder open deck plate girder**

27

### Design Basics, through girders

**Open and ballast deck through girder**

- Open deck on stringer-floorbeam floor system
- Knee braces at each floorbeam
- Steel plate ballast deck on a transverse floorbeam floor
- Floorbeams spaced ~3 – 4 feet apart
- Knee braces at 12' max spacing

28

### Design Basics, lateral layout

#### ARTICLE 1.2.4 SPACING OF TRUSSES, GIRDERS AND STRINGERS

- **Represents the lateral spacing of the supporting elements**
- Spacing sufficient to prevent overturning from design lateral loads
  - No less than  $L/20$  for through spans
  - No less than  $L/15$  for deck spans
- Minimum spacing of two-girder systems – 6'-6"
- Multiple girder systems: Arrange the girders to where the track load is evenly distributed (Maximum distributed deck width – 14 feet).



29

### Design Basics, deflection

#### ARTICLE 1.2.5 DEFLECTION

- **Two cases: vertical and lateral deflections**
- Component Stiffness

**Flexural members:** use the gross moment of inertia

**Truss members:**

- w/o perforated cover plates – use the gross area
- w/ perforated cover plates – use effective area
  - Effective area is the gross area minus the volume of the perforation divided by the distance center to center of the perforations



30

### Design Basics, deflection

#### Vertical Deflection

Prior to 1968, depth ratio was used; minimum depth of girder being  $1/12$  the length of the span.

After 1968, a deflection limit was more appropriate because of the introduction of various grades of steel.

**$L/640$  under Design Live Load plus full Design Impact** where  $L$  is the distance center to center of bearings for a simple span.



31

### Design Basics, deflection

#### Vertical Deflection – recommended section depth ratios

- **Two-girder (through or deck) spans –  $L/12$**
- **Four- or more girder spans –  $L/15$**
- **Trusses (through or deck) –  $L/10$**

**All beams or girders need a deflection check. Beams or girders shorter than recommended definitely need a deflection check.**

These were former recommendations replaced by  $L/640$ . They are still applicable to modern designs.



32

### Design Basics, deflection

#### Vertical deflection will control.

For bending sections, one of the first steps of design is calculating the required moment of inertia. Use that as a starting point in design.

For trusses, calculate the section sizes based upon the depth of the truss for moment of inertia.



33

### Design Basics, deflection

#### Why vertical deflection will control.

Railroad track, whether on soil embankment or bridge, is subject to federal inspection and regulation for track geometry limits, including fines under certain circumstances.

The purpose of a railroad bridge is not to support trains. The purpose of a railroad bridge is to maintain track geometry to standards while supporting trains.



34

### Design Basics, deflection

#### Lateral Deflection

Tangent track: 3/8" measured on a 62-foot chord  
Curved track: 1/4" measured on a 31-foot chord, but no more than 5/16" measured on a 62-foot chord.

Values are based on Federal Railroad Administration (FRA) track standards, representing half of the acceptable values for lateral shift of Class 5 track.

Deflection requirements are valid under all loadings except for seismic, wind on the unloaded bridge, and the stability check.



35

### Design Basics, camber

#### ARTICLE 1.2.10 CAMBER

- Girders
  - Length  $\leq$  90 feet – no camber required
  - Length  $>$  90 feet – camber to match dead load deflection
- Trusses
  - All lengths – camber to match a combination of dead load deflection and an assumed live load of 3000 plf (no impact)



36



**Design Basics. expansion**

**ARTICLE 1.2.13 PROVISION FOR EXPANSION**

- Minimum rate of 1" per 100 feet allowance
- Provision shall be made for change in length due to live load
- If  $L \geq 300'$  (truss), allowance for floor system expansion included
  - Traction Bracing (Longitudinal Load)
- Part 5, Chapter 15 includes provisions for bearing details



37

**Design Basics, design method**

**Allowable Stress Design**

- Used for design of steel railroad bridges
- Simply supported spans
- Deflection controls
- Allows simpler processing of rating and analysis for clearance loads
- All allowable stresses are shown in **Table 15-1-11 (Section 1.4)**.
- Because deflection controls, high-strength steels are not required.
- $F_y = 36$  or 50 ksi is adequate for most applications



38

**Design Basics, loads and forces**

**Loads and Forces (ARTICLE 1.3.1)**

- |                                    |                                      |
|------------------------------------|--------------------------------------|
| • Dead Load                        | • Other Lateral Forces               |
| • Live Load                        | • Longitudinal Forces                |
| • Impact Load                      | • Earthquake Forces                  |
| • Centrifugal Force – curved track | • Forces from Continuous Welded Rail |
| • Wind Forces                      | • Stability Check                    |



39

**Design Basics, loads and forces**

**Loads and Forces (ARTICLE 1.3.1) Primary concern for superstructures**

- |                                    |                                      |
|------------------------------------|--------------------------------------|
| • <u>Dead Load</u>                 | • Other Lateral Forces               |
| • <u>Live Load</u>                 | • Longitudinal Forces                |
| • <u>Impact Load</u>               | • Earthquake Forces                  |
| • Centrifugal Force – curved track | • Forces from Continuous Welded Rail |
| • Wind Forces                      | • Stability Check                    |
- For basic tangent alignment designs, these three loads will define the section



40



### Design Basics, dead load

Typical dead load values

**Steel Weight**

- Older references have formulae for steel weights
  - Dilworth, E. C.; *Steel Railway Bridges, Designs and Weights*; 1916; D. Van Nostrand Company; New York.
  - Ketchum, M. S.; *Structural Engineer's Handbook*; 1924; McGraw-Hill Book Company; New York.
  - Hool, G. A. and W. S. Kinne, ed.; *Steel and Timber Structures*; 1942; McGraw-Hill Book Company; New York.



41

### Design Basics, dead load

Typical dead load values

**Deck Weights (including rail/track)**

- Open Deck: 500 – 700 plf per track
- Timber or Steel Ballast Deck: ~2500 plf per track
- Concrete Deck Ballast Deck: 3500 – 4000 plf per track



42

### Design Basics, dead load

Typical dead load values

- Example: A 2021 Cooper E80 open deck design using a welded section will have similar gross section properties to a Cooper E40 open deck design using a riveted section with 1906 design rules.
- Reasons:
  - Higher current allowable stresses
  - Reduced design impact (rolling impact versus hammer blow impact)
  - Gross versus net section



43

### Design Basics, load and stress apportionment

Example is a longer span length

Category	Percentage
LIVE LOAD	78%
BALLAST	10%
BRIDGE STEEL	5%
WIND	4%
DECK	2%
RAIL	1%



44

### Design Basics, live load

**Cooper E80 Load**

Loads are axle loads (load per track).

45

### Design Basics, live load

**Cooper E80 Load**

- Load is shown as axle loads (load per track).
- **Table 15-1-15 (Section 1.15)** tabulates values for shear, moment, and pier/floorbeam reaction (load per rail)
- Interpolation of values from the table for design is allowable
- Load magnitudes are scalable to other levels of Cooper Load

46

### Design Basics, live load

**Alternate Load**

- Controls for short spans (50 feet or less)
- Design load wheelbase of 192" vs. 221" actual practice
- Axle loading of 400,000 lbs versus 286,000 lbs
- Alternate Load is 40% heavier than the current minimum load wheelbase and is 13% shorter.
- Useful in fatigue analysis

47

### Design Basics, load distribution

**ARTICLE 1.3.4 DISTRIBUTION OF LIVE LOAD**

The article describes the basics for distributing live load to the supporting elements. It is especially useful for deck design.

**For all longitudinal main supporting elements, no longitudinal distribution of load is assumed.** Place full concentrated loads on those elements in design.

- **OPEN DECKS:** Assumed to be timber bridge ties, and spread over 3 ties. Chapter 7, Timber Structures, has the detail on it. Bridge ties are designed as bending members.
- Check loaded flanges for **out-of-plane bending (Article 1.7.4)**

48

**Design Basics, load distribution**

**ARTICLE 1.3.4 DISTRIBUTION OF LIVE LOAD**

**OPEN DECKS** for girders/beams (deck design):

- **Longitudinal distribution**
  - Distribute over the smaller of 3 ties or 40 inches
- **Lateral distribution**
  - Load equally shared across main supporting members

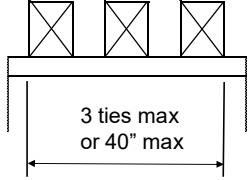

3 ties max  
or 40" max



49

**Design Basics, load distribution**

**ARTICLE 1.3.4 DISTRIBUTION OF LIVE LOAD**

- **BALLAST DECKS** for girders/beams (deck design):

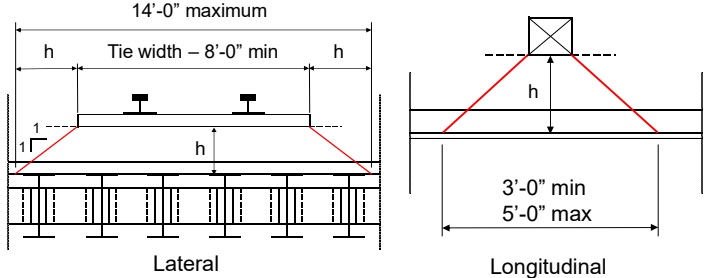

14'-0" maximum

h Tie width – 8'-0" min h

h

h

3'-0" min  
5'-0" max

Lateral

Longitudinal



50

**Design Basics, load distribution**

**ARTICLE 1.3.4 DISTRIBUTION OF LIVE LOAD**

- **TRANSVERSE STEEL FLOORBEAM** (through girders or trusses):
  - Refer to **Article 1.3.4.2.3** and follow the procedure



51

**Design Basics, live load impact**

**ARTICLE 1.3.5 IMPACT LOAD**

- **Article 1.3.4.2.4:** This clause calls for the load to be shared equally across all main structural elements, with the centroid of any element within the maximum deck width counting as a supporting element.
- The article has a second part saying that distribution of loads for other conditions shall be by a "recognized method of analysis."
- Essentially, make all the girders the same capacity. The other portion is part of the confusion on impact.



52

**Design Basics, live load impact**

**ARTICLE 1.3.5 IMPACT LOAD**

- Two basic parts; **Vertical Effect (VE)** and **Rocking Effect (RE)**
- **Total Impact = VE + RE**

**Vertical Effect**

- 1.3.5c(1) – **VE** for rolling equipment (diesel, electric, standard equipment)
- 1.3.5c(2) – **VE** for hammer blow (steam, possibly tourist railroads)
- Simple formulae based upon the length of the span





53

**Design Basics, live load impact**

**ARTICLE 1.3.5 IMPACT LOAD**

**Rocking Effect (RE)**

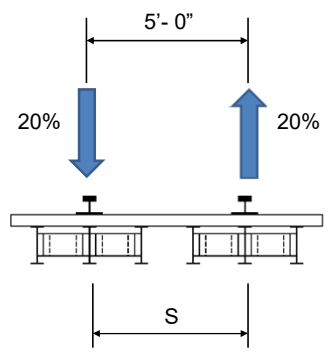
- 1.3.5d – A force couple of 20% of the wheel loads spaced at the center of the rails.
- Originally (1935) intended as strictly **100/S** where **S** was the center distance of the beam group supporting each rail



54

**Design Basics, live load impact**

**ARTICLE 1.3.5 IMPACT LOAD**

**Rocking Effect (RE)**

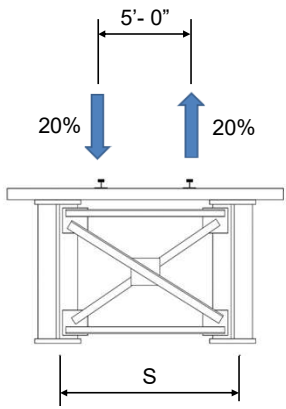
- Very useful for simple girder spans or through girders



55

**Design Basics, live load impact**

**ARTICLE 1.3.5 IMPACT LOAD**

**Rocking Effect (RE)**

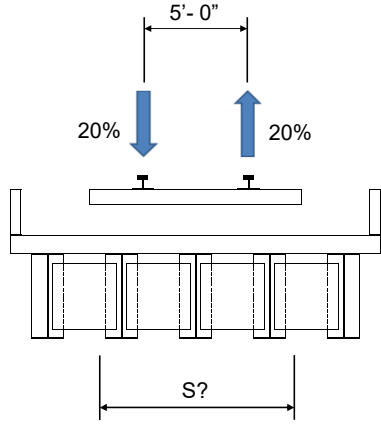
- But not so useful for other beam configurations

56

**Design Basics, live load impact**

**ARTICLE 1.3.5 IMPACT LOAD**

**Rocking Effect (RE)**

- Use the Moment of Inertia (MOI) method

$\sum d^2$

57

**Design Basics, live load impact**

**ARTICLE 1.3.5 IMPACT LOAD**

**Rocking Effect (RE)**

- Use 100/S

58

**Design Basics, live load impact**

**ARTICLE 1.3.5 IMPACT LOAD**

**Rocking Effect (RE)**

- Use MOI

59

**Design Basics, live load impact**

**ARTICLE 1.3.5 IMPACT LOAD**

- Use what fits for the situation for Rocking Effect
- Use the maximum value for all beams or girders

60



### Design Basics, lateral forces

#### Through Girder Knee Braces

- Lateral force – 2.5% of the flange force
- Some agencies take this that the 2.5% notional load as needing to be applied as live load bending moment onto the floor beam
- **NO!**
- Strictly for shear and stability of the knee brace
- The 2.5% notional force is used in various clauses of Part 1 for lateral force design only

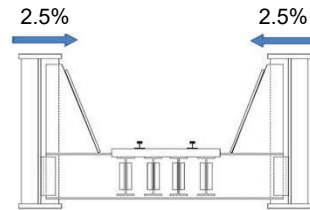

61

### Design Basics, gusset plates

#### ARTICLE 1.5.4 Thickness of Material

#### Gusset Plate Design

- Uses the Whitmore section for determining the critical section for buckling
- Figure 15-9-4 (Article 9.1.5.4b) has been modified to demonstrate the critical sections for full and partial shear plane behavior. This is not in the current manual (2022).



62

### Design Basics, longitudinal forces

#### ARTICLE 1.3.12 Longitudinal Force

- Modern locomotives create both high braking and traction forces
- Formulae for traction and braking in Article 1.3.12 reflect the maximum
- Longitudinal force is situational: acceleration, braking, and grades
- Longitudinal force levels depend upon train size and consist
- Consult **Article 9.7.3.2.8 (Tables 15-9-9 and 15-9-10)**. Comparative data is shown for different types of trains and grades providing expected levels of longitudinal force



63

### Design Basics, longitudinal forces

#### ARTICLE 1.3.12 Longitudinal Force

- Level of force transmitted through the span to the bearings is indeterminate.
- Recommend having sufficiently sized anchor bolts to resist the design longitudinal force in shear.
- Check expansion length of the span



64

### Design Basics, bearings

#### PART 5, BEARINGS

- Use as simple a bearing as possible
- Steel flat plate bearings are still acceptable for short spans
- Elastomeric and laminated elastomeric pads are also common
- POT BEARINGS NOT RECOMMENDED. Generally unsuitable for rail use
- **Table 15-5-1 (Article 5.1.1.3) Bearing Suitability Chart** is a great tool for picking the type of bearing needed for a given application



65

### Design Basics, fatigue

#### Article 1.3.13 FATIGUE

- Method is the same process as AASHTO
  - **L ≤ 100 feet: Over 2,000,000 cycles**
  - **L > 100 feet: 2,000,000 cycles**
  - Reduced Live Load Impact (**Table 15-1-7**) depending upon member type
  - **Table 15-1-8** contains the detail drawings and categories
  - **Table 15-1-9** shows the category stress ranges



66

Part 2

## Guidance on Application of D1.5 Fracture Control Plan and Weld Type Selection in Railway Bridges

Prof. Robert J. Connor  
Lyles School of Civil Engineering  
Purdue University

PURDUE  
UNIVERSITY

67

### “It’s Better”

- Universally, we all want to have the “Best” steel bridge
- However, some decisions we may think will result in improvements, don’t always add value
  - *Sometimes* these decisions can result in lower quality
- Therefore, it is good to discuss things that should not be specified unless actually warranted based on engineering
  - “*Well, I think it’s better*” is not the attitude to have

68

### Areas of Discussion

- AASHTO/AWS Fracture Control Plan (FCP)
  - Specification of FCMs
- Weld type selection
  - Fillet, vs PJP, vs CJP



69

### Prevention of Brittle Fracture

- Historically, brittle fractures are due to one of two causes
  - First
    - Welding “issues” that produced defects which grew in fatigue resulted in subsequent fractures or pure fatigue that resulted in crack development and subsequent fracture, often in combination with low toughness
  - Second
    - Details that were susceptible to brittle fracture in the absence of any fatigue cracking.
    - Commonly referred to as Constraint Induced Fracture (CIF)

70

### Prevention of Brittle Fracture

- Interesting, routine modern fabrication and design provisions have effectively eliminated fractures due to the first cause
  - i.e., non-FCMs don't fracture either
- Fracture due to CIF is prevented through proper detailing
  - Chapter 15 has adopted details that are not susceptible to CIF
  - Likely these details will be further updated to reflect improved information based on research from a recent FHWA project

71

### General Background to the Current FCP

- Developed in response to brittle fractures in non-redundant tension members in the 1970s
  - Specifically for welded non-redundant steel tension members in highway bridges
- Objective of the current FCP is to reduce the likelihood of brittle fractures occurring in non-redundant steel tension members
- However, a true FCP should consider the consequence of the fracture in conjunction with likelihood...i.e., a risk-based approach
  - In other words, "fracture control plan" should "control" the overall risk associated with a fracture

72

### Risk-based Approach to an FCP

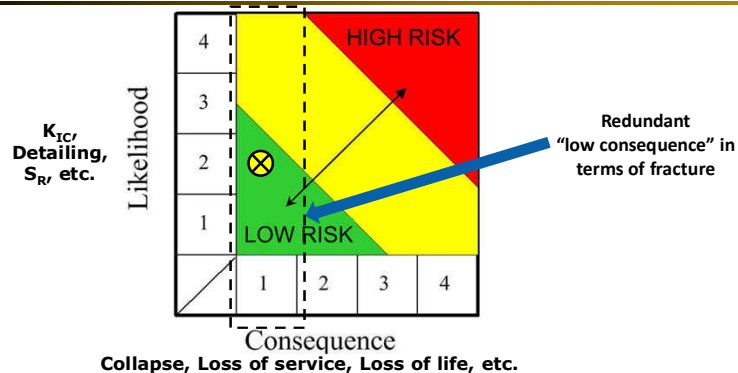

73

### General Background to the Current FCP

- How is consequence "considered" in the current FCP?
  - FCP provisions are not invoked for redundant steel tension members.
- In other words, if it is determined a member is redundant, the consequence and by extension the risk of a failure is deemed less
- Therefore, provisions are intended to decrease the likelihood of fracture when consequence of fracture is "high"
  - As in a non-redundant member

74



### General Background to the Current FCP

- As stated, the FCP was developed in the context of highway bridges
- The FCP provisions are contained in AWS D1.5 provisions
  - Specifically, Clause 12
- AREMA adopted the AWS Clause 12 FCP provisions
- Specific AREMA articles are:
  - 1.14 Fracture-Critical Members
  - 9.1.14 – Associated commentary

75

### AREMA Definition of a FCM

- The FCP shall only be applied to Fracture-Critical Members (FCMs)
- AREMA Definition (1.14.1a):

*..those tension members or tension components of members whose failure would be expected to result in collapse of the bridge*  
or  
*inability of the bridge to perform its design function*

76

### FCM Definition

- While the definition seems simple, there is considerable variability in what members engineers classify as FCMs
- The biggest reason is due the belief that the FCP will result in “better” members
  - I want a “better” bridge...so lets call it an FCM
- Lets study the AREMA definition a bit...

77

### FCM Definition

- AREMA Definition (1.14.1):
  - First part (a)...

*..those **tension members** or **tension components of members** whose failure would be expected to result in collapse of the bridge*

78



### Requirement for Tension in the FCM Definition

- Thus an FCM **must** be subjected to net tensile stresses from either axial or bending forces
- It is recognized that for brittle fracture to occur and propagate, tensile forces that exceed any compressive forces must be present in the member
  - For example, a member that carries 100 kips in dead load compression but 200 kips in live load tension would satisfy this portion of the definition since the net force is tension

79

### FCM Definition

- As another example, consider a **two-girder** simple-span plate girder

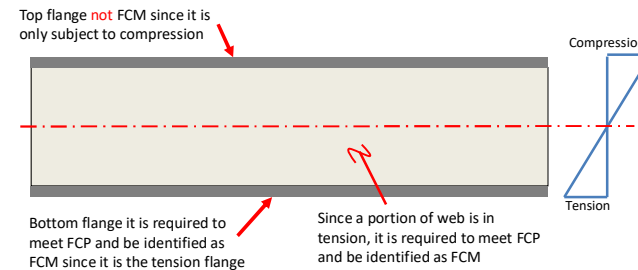

80

### FCM Definition

- AREMA Definition (1.14.1):
  - First part (b)...
    - *..those tension members or tension components of members whose failure would be expected to result in collapse of the bridge*
- Thus, the member **MUST** be non-redundant

81

### Concept of Collapse in the FCM Definition

- Members such as the lower tension chord of a truss, single or double eyebars, or pin and link hangers, are typically considered as non-redundant members, and identified as FCMs
  - It is presumed that if the member were to fail in brittle fracture, it could trigger the collapse of the bridge.
- It is these types of members that were on the minds of the individuals who developed the FCP
  - Thus, don't classify as a FCM without real engineering justification... importance or significant load is not such a reason

82

### Concept of Collapse in the FCM Definition

- In contrast however, the tension flanges in multi-girder bridges are not considered FCMs
  - It is assumed that the adjacent girders can provide a redundant load path and sufficient load capacity in the event of a fracture of any given girder
- Simply put, if there is an alternate load path, the member is redundant and should not be considered fracture critical
  - i.e., a redundant member, should not be considered fracture critical.
  - FHWA refers to these as “System Redundant Members” (SRMs)

83

### Other things to Keep in Mind Regarding FCP

- Specifying a member as an FCM adds cost
  - Estimated to be about 10-15% of total steel fabrication cost
- Very important to recognize that the FCP does not change the outcome (consequence) should a fracture occur
  - A fractured girder is still a fractured girder no matter how you identify it on the plans
- Fractures in non-FCMs are incredibly rare
  - Modern fabrication, design, material, etc. etc. etc. produce highly reliable girders
  - Take away? Non-FCMs don't fracture!

84

### “Design Function” in the FCM Definition

- AREMA Definition (1.14.1a):
  - Second part ...  
members whose failure would be expected to result in the...  
**inability of the bridge to perform its design function.**
- This is more difficult to determine and quite open to interpretation since the phrase “*inability of the bridge to perform its design function*” is vague
  - Failure of one of six girders “could” result in loss of function
    - But so could failure of a cross frame (please don't call cross frames FCMs!!!!)
  - However, with deflection or fatigue controlling design and in an ASD philosophy, major impacts to “design function” seem unlikely
  - AASHTO removed similar language since it is vague and difficult to quantify

85

### What do you Think?

- For example:
  - Assume there are 5 or 6 girders in a 75-foot span bridge supporting a single track
  - Assume the girders are spaced at 2 to 3 feet
  - Assume there are heavy cross braces or diaphragms
  - Assume composite concrete deck supporting ballasted track
- Should these girders be considered FCMs?

**NO!**

86



### AWS Guidance on Specifying the FCP

- Further, from the Commentary C-12.1 of AWS D1.5

*Fracture critical classification is not intended for "important" welds on non-bridge members or ancillary products, rather it is only intended to be for those members whose failure would be expected to result in a catastrophic collapse of the bridge.*

The take-away? The FCP is not intended for use on anything but bridges and really only relates to collapse

87

### AWS Guidance on Specifying the FCP

- From the Commentary C-12.1 of AWS D1.5

*The Fracture Control Plan should not be used indiscriminately by designers as a crutch "to be safe" and to circumvent good engineering practice.*

- Please review the article in Modern Steel Construction: "Are You Sure That's Fracture Critical" for additional guidance (January, 2015 issue)

88

### A Few Words about Weld Type Selection

- Vacation from work
  - A little is good, More is better
- Cash in your pocket
  - A little is good, More is better
- Welding
  - A little is good, More is better

yes  
 no

yes  
 no

yes  
 no

89

### CJP Welds Add Considerable Time/Cost

- Joint preparation (beveling) adds time
- CJP welds will require multi-pass welds adding time
  - May be many passes depending on plate thickness
  - Will require root back-gouging and cleaning between passes
- More rigorous procedures often required (preheat, etc.)
- Requires 100% RT/UT inspection for internal defect detection
  - Specifying CJP suggests internal defects are unacceptable
  - e.g., 100 feet of web-to-flange weld requires 100% UT inspection from both sides of web and possibly through flange
    - If top and bottom flanges specified, that's 200 feet
  - Often adds repairs in a weld (i.e., CJP vs fillet) that was not needed in the first place

90

### A Few Examples

- Railway bridge engineers seem to like to specify CJP welds for joints, often even when they are not needed for performance
- View is “they are “better”
- Should only specify when needed based on engineering (i.e., load)
  - CJP butt splice in a flange? Certainly
  - Web-to-flange weld at top flange, open deck? Maybe?
  - Web-to-flange weld at top flange, comp. conc. deck w/ ballast? No
  - Web-to-flange weld at bottom flange? No

### Fatigue Cracking Modes – Fillet Weld

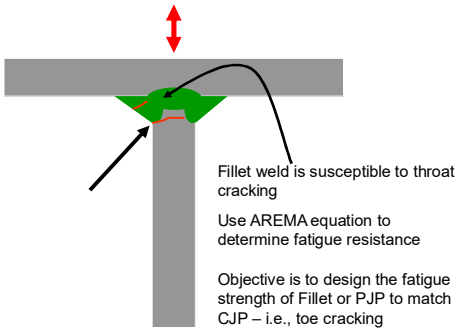

### Example of Fabrication Efforts

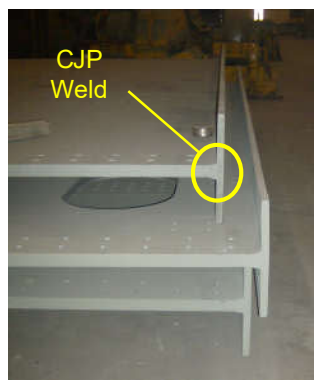

### Flange Plates Bent Prior to Placing Full Penetration Weld





### Flange Plates Flat after Placing Full Penetration Weld

95

### Summary

- Specifying requirements to make a structure “better” in the absence of engineering is simply adding cost with no benefit
  - Don't specify as a FCM for all steel components in tension
    - That was never intended when FCP/FCM concepts were developed
    - AWS D1.5 is clear that the FCP should not be specified arbitrarily
  - Don't specify CJP welds when they are not needed
    - Specifically, CJP web to flange welds should only be specified when needed in open deck systems
      - If concerned about fatigue in open deck, should still check toe cracking even if CJP is specified
    - Highly unlikely CJP ever needed when composite concrete deck is used in conjunction with ballasted track
    - Never needed in web-to-flange weld at bottom flange
      - There is no transverse (vertical) load applied

96



### Questions

PURDUE  
UNIVERSITY

97

### PDH Certificates

- Reporting site (URL will be provided in the forthcoming email).
- Username: Same as AISC website username.
- Password: Same as AISC website password.



Smarter.  
Stronger.  
Steel.





AISC | Thank you



Smarter.  
Stronger.  
Steel.



Copyright © 2021  
American Institute of Steel Construction