

## AISC Live Webinars

Thank you for joining our live webinar today.  
We will begin shortly. Please standby.

Connection Design for Moment Frames and Braced Frames  
Session 3: Introduction to Seismic Connections  
March 4, 2020



## AISC Live Webinars

**Today's live webinar will begin shortly. Please stand by.**

Today's audio will be broadcast through the internet. Please be sure to turn up the volume on your speakers.

Please type any questions or comments through the chat feature in the left portion of your screen.



## AISC Live Webinars

### AIA Credit

AISC is a Registered Provider with The American Institute of Architects Continuing Education Systems (AIA/CES). Credit(s) earned on completion of this program will be reported to AIA/CES for AIA members. Certificates of Completion for both AIA members and non-AIA members are available upon request.

This program is registered with AIA/CES for continuing professional education. As such, it does not include content that may be deemed or construed to be an approval or endorsement by the AIA of any material of construction or any method or manner of handling, using, distributing, or dealing in any material or product.

Questions related to specific materials, methods, and services will be addressed at the conclusion of this presentation.



## AISC Live Webinars

### Copyright Materials

This presentation is protected by US and International Copyright laws. Reproduction, distribution, display and use of the presentation without written permission of AISC is prohibited.

© The American Institute of Steel Construction 2020

The information presented herein is based on recognized engineering principles and is for general information only. While it is believed to be accurate, this information should not be applied to any specific application without competent professional examination and verification by a licensed professional engineer. Anyone making use of this information assumes all liability arising from such use.



## AISC Live Webinars

### Course Description

Introduction to Seismic Connections  
March 4, 2020

This session will provide an overview of seismic connections for engineers that don't typically perform seismic design. The concepts of ductile mechanisms and capacity design will be introduced. The characteristics of special and intermediate moment frame connections will be explained, and the current prequalified moment connection types will be discussed. The session will also cover the design of special concentrically braced frame connections. Brief design examples, highlighting key calculations for both moment connections and bracing connections, will be presented to demonstrate concepts.



## AISC Live Webinars

### Learning Objectives

- Describe the role of ductility in seismic design.
- Explain how to check the strong column-weak beam requirement for special moment frames.
- List the steps for the design procedure of a reduced beam section moment connection.
- Identify several unique design requirements for special concentrically braced frame connections.



## Connection Design for Moment Frames and Braced Frames

Session 3: Introduction to Seismic Connections  
March 4, 2020



Matthew Eatherton, PhD, SE  
Associate Professor, Virginia Tech  
Blacksburg, Virginia



## SCHEDULE

- February 19, 2020 Moment Connections Part I
- February 26, 2020 Moment Connections Part II
- March 4, 2020 Introduction to Seismic Connections
- March 11, 2020 Bracing Connections



# INTRODUCTION TO SEISMIC CONNECTIONS

9

## TOPICS

Introduction to Seismic Connections:

- Overview and Basics of Seismic Design
- Special Moment Frame (SMF) Connections
  - AISC 358-16
  - Reduced Beam Section (RBS)
- Special Concentrically Braced Frame (SCBF) Connections
  - Fold Lines
  - Limit States

10

## OVERVIEW AND BASICS OF SEISMIC DESIGN

**Audience**

- Intended for non-seismic experts

**Objectives**

- Introductory information
- Schematic examples provided
- Focus on aspects unique to seismic

11

## Role of Ductility

**Key Concept: Ductility**

- Ductility: The ability to deform inelastically without significant loss of strength.
- Buildings survive earthquakes through ductility.
- Buildings deform, dissipate energy, resist collapse.

12

### Material vs. Building Ductility



**Material Level Ductility:**

$$\mu_e = \frac{\epsilon_{max}}{\epsilon_y}$$

Typical structural steels:  
 $\mu_e = 100$  to  $200$

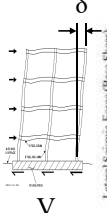

**Building Level Ductility:**

$$\mu_\delta = \frac{\delta_{max}}{\delta_y}$$

Typical:  $\mu_\delta = 1$  to  $5$

- Ductility of a building is much smaller than material ductility.
- Inelastic strains concentrate and potential for nonductile limit states.
- Try to spread inelasticity, limit deformation concentrations, delay fracture and collapse.

13

### Role of Ductility

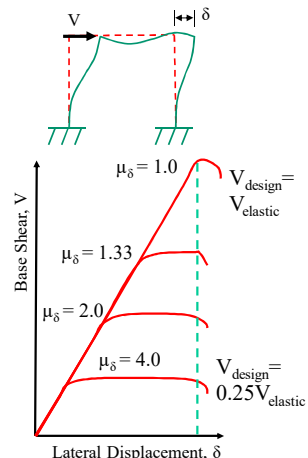

Y-axis: Base Shear,  $V$   
 X-axis: Lateral Displacement,  $\delta$

Curves shown for  $\mu_\delta = 1.0, 1.33, 2.0, 4.0$

Design shear levels:  $V_{design} = V_{elastic}$  and  $0.25V_{elastic}$

- Earthquake effects
  - Earthquakes are more like an applied displacement than an applied force.
- As System Ductility  $\uparrow$ 
  - $\downarrow$  Required Strength
  - $\downarrow$  Amount of Materials
  - $\uparrow$  Detailing and Connection Cost
  - $\uparrow$  Inspection Requirements
- Economical Buildings
  - For high seismic, highest ductility system typically wins.
  - For low seismic, not enough reduction in materials.

14

### Design Forces vs. Actual Forces

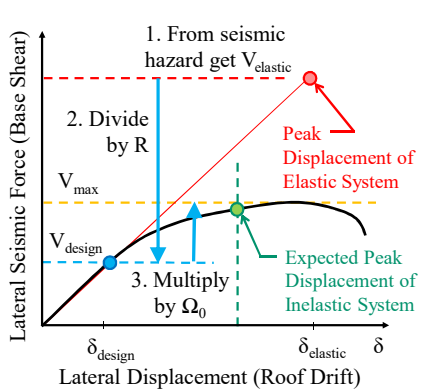

Y-axis: Lateral Seismic Force (Base Shear)  
 X-axis: Lateral Displacement (Roof Drift),  $\delta$

1. From seismic hazard get  $V_{elastic}$

2. Divide by  $R$

3. Multiply by  $\Omega_0$

Labels:  $V_{max}$ ,  $V_{design}$ ,  $\delta_{design}$ ,  $\delta_{elastic}$

Annotations: Peak Displacement of Elastic System, Expected Peak Displacement of Inelastic System

ASCE 7-16 Ch. 12 Commentary

- Design Forces
  - $R =$  Response Modification Factor
  - $V_{design} = \frac{V_{elastic}}{R}$
- Actual Forces
  - Estimate actual base shear:  $V_{max} = \Omega_0 V_{design}$
  - However, many local forces / moments don't scale with  $\Omega_0$ .
  - Use capacity design.

15

### Ductile Mechanisms

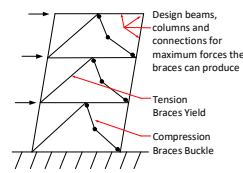

Special Concentrically Braced Frame (SCBF)

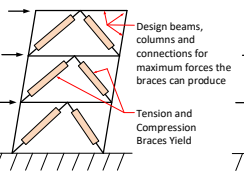

Buckling Restrained Braced Frame (BRBF)

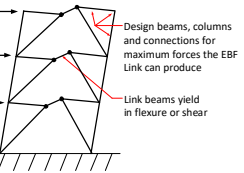

Eccentrically Braced Frame (EBF)

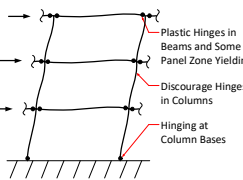

Special Moment Resisting Frame (SMRF)

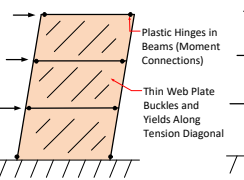

Special Plate Shear Wall (SPSW)

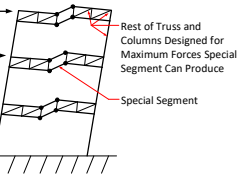

Special Truss Moment Frame (STMF)

16

### Designing Rest of Load Path

- Overstrength Factor,  $\Omega_0$ 
  - Calibrated for base shear ( $V_{max} = \Omega_0 V_{design}$ )
  - Not all forces / moments scale the same way: ( $F_{max} \neq \Omega_0 F_{design}$ )

Example: Analysis of a Chevron Frame

- Allowed for some ordinary systems.

- Capacity Design
  - Design for maximum forces the ductile mechanism can produce.
  - May need to consider different scenarios.

Compression  
Brace at Buckling Strength

Compression  
Brace Post-Buckling Strength

- Required for most systems in *Seismic Provisions*

17

### When to Use the Seismic Provisions

ASCE 7-16 Table 12.2-1 – 85 Systems Listed

Seismic Force Resisting System	Detailing Requirements	R	$\Omega_0$	$C_d$	Height Limits					
					B	C	D*	E*	F*	
<small>Structural System Limitations including Structural Height, <math>R_y</math>, <math>\Omega_0</math> Limits<sup>a</sup></small>										
<small>Seismic Design Category</small>										
<small>Seismic Force Resisting System</small>										
<small>ASCE 7 Section Where Detailing Requirements Are Specified</small>										
<small>Response Modification Coefficient, <math>R_y</math></small>										
<small>Overstrength Factor, <math>\Omega_0^b</math></small>										
<small>Deflection Amplification Factor, <math>C_d^c</math></small>										
<small>B. BUILDING FRAME SYSTEMS</small>										
<small>1. Steel eccentrically braced frames</small>										
<small>2. Steel special concentrically braced frames</small>										
<small>3. Steel ordinary concentrically braced frames</small>										
<small>H. STEEL SYSTEMS NOT SPECIFICALLY DETAILED FOR SEISMIC RESISTANCE, EXCLUDING CANTILEVER COLUMN SYSTEMS</small>										
B2. Steel special concentrically braced frames		6	2	5						All steel systems in list require AISC 341
H. Steel systems not specifically detailed for seismic resistance		3	3	3						One exception

18

### References

#### Necessary References

**AISC 341-16**  
Seismic Provisions

**AISC 358-16**  
Prequalified Connections

Free download from:  
[www.aisc.org/publications/steel-standards/](http://www.aisc.org/publications/steel-standards/)

#### Useful Reference

**Seismic Design Manual** – Contains the other two, plus tables and examples

19

### Expected Strength of Ductile Mechanism

- Expected yield stress,  $F_{y-expected} = R_y F_y$ 
  - Table A3.1 in AISC 341-16 (Excerpt)

Application	$R_y$	$R_t$
Hot-rolled structural shapes and bars:		
• ASTM A36/A36M	1.5	1.2
• ASTM A1043/A1043M Gr. 36 (250)	1.3	1.1
• ASTM A992/A992M	1.1	1.1
• ASTM A572/A572M Gr. 50 (345) or 55 (380)	1.1	1.1
• ASTM A913/A913M Gr. 50 (345), 60 (415), 65 (450), or 70 (485)	1.1	1.1
• ASTM A588/A588M	1.1	1.1
• ASTM A1043/A1043M Gr. 50 (345)	1.2	1.1
• ASTM A529 Gr. 50 (345)	1.2	1.2
• ASTM A529 Gr. 55 (380)	1.1	1.2
Hollow structural sections (HSS):		
• ASTM A500/A500M Gr. B	1.4	1.3
• ASTM A500/A500M Gr. C	1.3	1.2

20

## Role of Connections

- Role of Connections in Seismic Design
  - Ductility is intimately tied to connection detailing.
  - Based on tests.
  - Types of requirements: materials, geometry, weld detailing, surface roughness, etc.
- Focus for This Session
  - Seismic Provisions include OMF, IMF, SMF, STMF, OCCS, SCCS, OCBF, SCBF, EBF, BRBF, SPSW, Composite.
  - Focus on two common systems:
    - Special moment frames (SMF)
    - Special concentrically braced frames (SCBF)



21

## SPECIAL MOMENT FRAME (SMF) CONNECTIONS

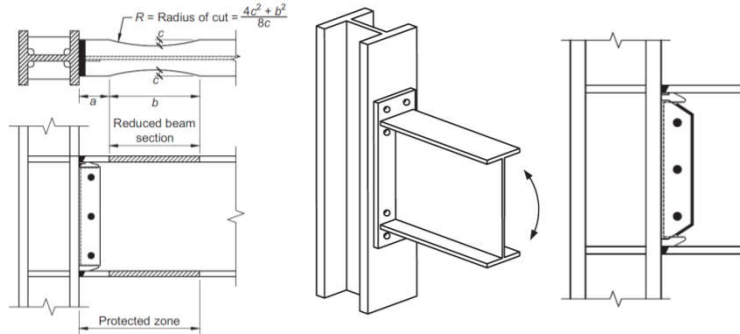

$R = \text{Radius of cut} = \frac{4c^2 + b^2}{8c}$



22

## Northridge Earthquake Fractures

- Description
  - January 17, 1994 Northridge Eq.  $M_w = 6.7$
  - Hundreds of MRF buildings had fractures (no collapses)
  - January 17, 1995 Kobe Eq.  $M_w = 6.9$  - Similar fractures
- Pre-Northridge Moment Connections
  - Fracture typically occurred at bottom flange.

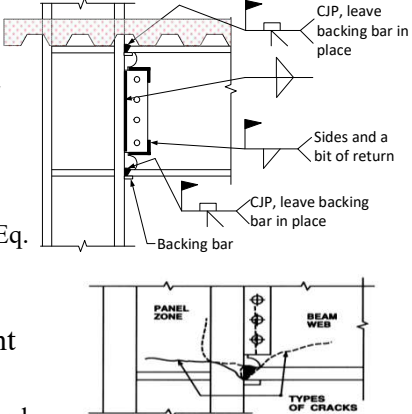



Figure 2 Some failure modes of the welded beam-to-column connection [From Popov et al. 1998]



23

## Northridge Fractures - Causes

- Contributing Factors
  1. Backing bar at bottom flange – effective crack.
  2. Weld quality poor at bottom flange root and starts / stops at middle.
  3. Composite slab shifts neutral axis up – larger strains at bottom flange.
  4. Weld access hole geometry.
  5. Weld filler material low toughness.
  6. Panel zones were weaker.
- Implications
  - SMF and IMF connections must be tested at full scale.
  - Pass qualification criteria.

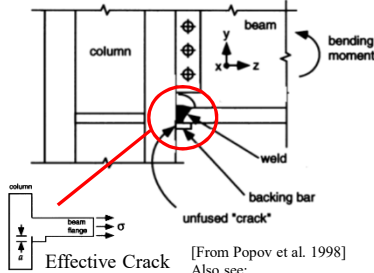

[From Popov et al. 1998] Also see: Miller 1998, FEMA 350



24

### Overview of SMF Design

Will Discuss Today

- Primary Checks
  1. Drift (ASCE 7-16)
  2. Connection capable of 0.04 rad story drift (§E3.6b/c)
  3. Highly ductile section for beams and columns (§E3.5a)
  4. Strong Column Weak Beam (Moment Ratio) (§E3.4a)
  5. Shear strength of connection (§E3.6d)
  6. Panel zone shear (§E3.6e)
  7. Continuity plates (§E3.6f)

- Additional Requirements
  1. Bracing of Beams (§E3.4b)
  2. Shared columns in orthogonal frames (§E3.3)
  3. Protected Zone (§E3.5c)
  4. Demand Critical Welds (§E3.6a)
  5. Column splices (§E3.6g)
  6. Clear span to depth ratio for beams (AISC 358)

Sections cited are in AISC 341-16



25

### Ductility and SMF Design

Ductile Mechanism is Plastic Hinging at Beam Ends

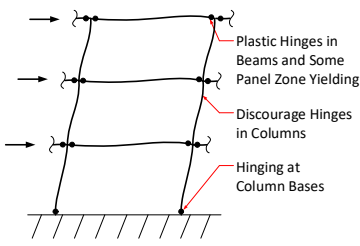

- Connection type with proven ductility (0.04 rad)
- Beams and columns capable of large rotations (highly ductile section criteria)

- Prevent story mechanisms (Strong-Column-Weak-Beam)
- Limit local column deformations that can otherwise reduce ductility (panel zone and continuity plates)
- Restrict attachments in plastic hinges (protected zone)
- High toughness weld filler metal at hinges (demand critical welds)



26

### SMF Connection Conformance

- Requirement (§E3.6b)
  1. Full-scale tests.
  2. Cyclic loading up to story drift of 0.04 rad.
  3. Must retain moment strength of 0.80  $M_p$  (nominal).
- Ways to Show Conformance
  1. Use a connection in AISC 358-16 (prequalified).
  2. Use a connection prequalified by someone else.
  3. Conduct two qualifying tests identical to your building.

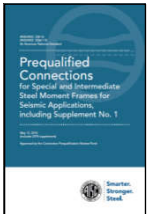

AISC 358-16  
 Ductile Limit State,  $\phi_d = 1.0$   
 Nonductile Limit State,  $\phi_n = 0.9$



Qualification Testing



27

### AISC 358-16 Prequalified Conn. 1/3

Each connection has its own limits on prequalification.

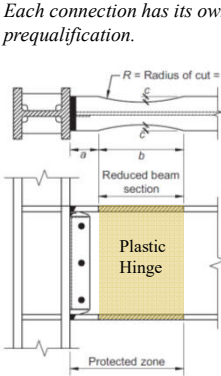

- Shifts plastic hinge away from column face.
- Protects beam-to-column welds.
- Slight reduction in stiffness.

1. Reduced Beam Section (RBS)

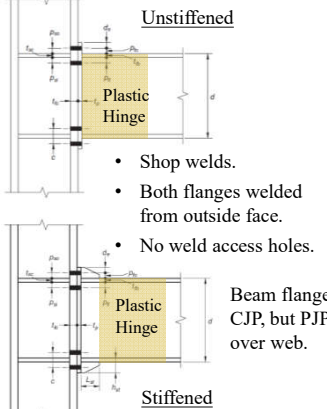

- Shop welds.
- Both flanges welded from outside face.
- No weld access holes.

2. Extended End-Plate Connections



28

### AISC 358-16 Prequalified Conn. 2/3

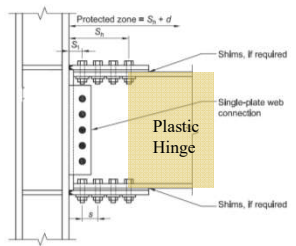

Protected zone =  $S_x + d$

Shims, if required

Single-plate web connection

Plastic Hinge

Shims, if required

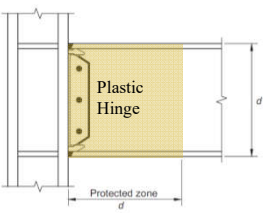

Plastic Hinge

Protected zone

$d$

- Plastic hinge shifts away from welds.
- Slip of flange plate bolts occurs.
- Flange plates shop welded to column.

3. Bolted Flange Plate

- Allows plastic hinge up to face of column.
- Special weld access hole geometry.
- Special detailing requirements for beam weld to column.

4. Welded Unreinforced Flange – Welded Web (WUF-W)

29

### AISC 358-16 Prequalified Conn. 3/3

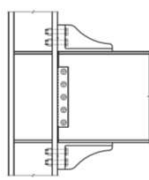

5. Kaiser Bolted Bracket

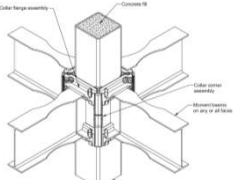

6. ConXtech® ConXL™

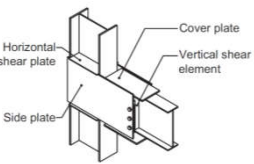

7. Side Plate®

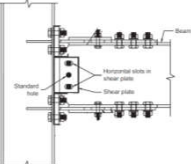

8. Simpson Strong-Tie® Strong Frame®

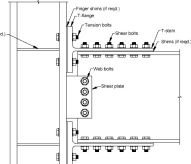

9. Double-Tee

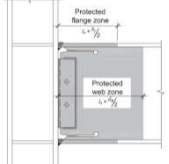

10. SlottedWeb®

30

### Highly Ductile Members

- Section Compactness (*Provisions §D1.1*)
  - Delay local buckling.
  - §E3.5a requires highly ductile section for beams and columns.
  - Also bracing requirements.

Flanges of I-Shape

$$\frac{b_f}{2t_f} \leq 0.32 \sqrt{\frac{E}{R_y F_y}}$$

Web of I-Shape

If  $C_a \leq 0.114$       If  $C_a > 0.114$

$$\frac{h}{t_w} \leq 2.57 \sqrt{\frac{E}{R_y F_y}} (1 - 1.04 C_a) \quad \frac{h}{t_w} \leq \left[ 0.88 \sqrt{\frac{E}{R_y F_y}} (2.68 - C_a) \geq 1.57 \sqrt{\frac{E}{R_y F_y}} \right]$$

$$C_a = \frac{P_u}{\phi_c P_y}$$

$$P_y = R_y F_y A_g$$

$$F_y \text{ expected} = R_y F_y$$

Table A3.1 in AISC 341-16  
 $R_y = 1.1$  for A992

Note: Presenting LRFD only, not showing ASD version of  $C_a$

31

### Highly Ductile Members - Example

- Determine if the following section is highly ductile  
 A992 W24x62 with axial force  $P_u = 100$  kips to be used as SMF Beam.

$$\frac{b_f}{2t_f} = 5.97$$

$$\frac{h}{t_w} = 50.1$$

$$A = 18.2 \text{ in}^2$$

From Table 1-1  
in the Manual.

– Check Flanges:

$$0.32 \sqrt{\frac{E}{R_y F_y}} = 0.32 \sqrt{\frac{29,000 \text{ ksi}}{(1.1)(50 \text{ ksi})}} = 7.35$$

$$\left[ \frac{b_f}{2t_f} = 5.97 \right] \leq \left[ 0.32 \sqrt{\frac{E}{R_y F_y}} = 7.35 \right]$$

Flanges satisfy highly ductile limit.

32



### Highly Ductile Members - Example

– Check Web: A992 W24x62 with  $P_u = 100$  kips

$$C_a = \frac{P_u}{\phi_c P_y} = \frac{P_u}{\phi_c R_y F_y A_g} = \frac{100 \text{ kips}}{0.9(1.1)(50 \text{ ksi})(18.2 \text{ in}^2)} = 0.111$$

Since  $C_a \leq 0.114$

$$2.57 \sqrt{\frac{E}{R_y F_y}} (1 - 1.04 C_a) = 2.57 \sqrt{\frac{29,000 \text{ ksi}}{(1.1)(50 \text{ ksi})}} [1 - 1.04(0.111)] = 52.2$$

$$\left[ \frac{h}{t_w} = 50.1 \right] \leq 52.2 \quad \text{Web satisfies highly ductile limit.}$$

**Section satisfied highly ductile compactness criteria**

– Table 1-3 or Table 4-2 in AISC Seismic Design Manual shows this also.





33

### Strong-Column-Weak-Beam (SCWB)

- **Moment Ratio (Provisions §E3.4a)**
  - Project the beam and column moments to center of connection.
  - Sum of column moments should be greater.  $\frac{\sum M_{pc}^*}{\sum M_{pb}^*} > 1.0$
  - Force the beam plastic hinges to occur at multiple levels.

$S_h$  is distance to plastic hinge. See AISC 358.

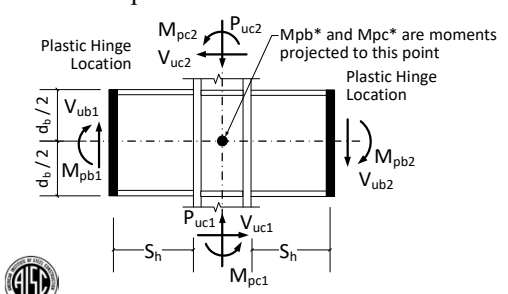
- $S_h = a + b/2$  for RBS.
- $S_h = \min\{d/2, 3b_{bf}\}$  for Unstiff End Plate.
- $S_h = \text{end of stiffener in Stiffened End Plate.}$
- $S_h = 0$  for WUF-W.

34

### Strong-Column-Weak-Beam (SCWB)

- **Beam Moment**  $C_{pr}$  accounts for strain-hardening.

$$M_{pr} = C_{pr} R_y F_y Z_e$$

Eqn. (2.4-1)

$$C_{pr} = \frac{F_y + F_u}{2F_y} \leq 1.2 \quad \text{Typical unless otherwise specified in AISC 358.}$$

$C_{pr} = 1.4$  for WUF-W

$Z_e = \text{effective plastic section modulus}$

$V_{ub} = \text{Shear due to plastic hinging} + \text{Shear due to gravity loads}$

$$V_{ub} = \frac{2M_{pr}}{L_h} + V_{u \text{ gravity}}$$

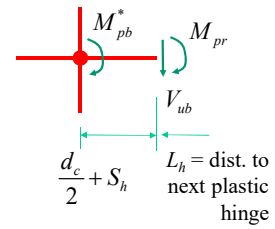
$$M_{pb}^* = M_{pr} + V_{ub} \left( \frac{d_c}{2} + S_h \right)$$

$L_h = \text{dist. to next plastic hinge}$

*Note: Presenting LRFD only, neglecting  $\alpha_s$  term for ASD*



35

### Strong-Column-Weak-Beam (SCWB)

- **Column Moment**
  - Does not use expected yield stress,  $R_y F_y$ .
  - Does not use strain hardening factor,  $C_{pr}$ .
  - Can neglect additional moment due to column shear,  $V_c d_b / 2$

$$M_{pc} = Z_c \left( F_{yc} - \frac{P_{uc}}{A_g} \right)$$

$$M_{pc}^* = M_{pc}$$

- **Moment Ratio**
  - Sum for all beams and columns framing into joint.  $\frac{\sum M_{pc}^*}{\sum M_{pb}^*} > 1.0$



36

### SCWB Example

- Determine if strong-column-weak-beam is satisfied
  - Beam Moment

Stiffened Extended End-Plate Connection

$$C_{pr} = \frac{F_y + F_u}{2F_y} = \frac{50 \text{ ksi} + 65 \text{ ksi}}{2(50 \text{ ksi})} = 1.15 < 1.2$$

$R_y = 1.1$  Table A3.1 for A992

$Z_x = 581 \text{ in}^3$  for W36x150

$$M_{pr} = C_{pr} R_y F_y Z_x$$

$$M_{pr} = (1.15)(1.1)(50 \text{ ksi})(581 \text{ in}^3)$$

$$M_{pr} = 36,750 \text{ k-in.}$$

37

### SCWB Example

- Determine if strong-column-weak-beam is satisfied
  - Beam Moment

$$V_{ub} = \frac{2M_{pr}}{L_h} + V_{u \text{ gravity}} = \frac{2(36,750 \text{ k-in.})}{(312 \text{ in.})} + 30 \text{ kips} = 265 \text{ kips}$$

$$M_{pb}^* = M_{pr} + V_{ub} \left( \frac{d_c}{2} + S_h \right)$$

$$M_{pb}^* = (36,750 \text{ k-in.}) + (265 \text{ kips}) \left( \frac{19.0 \text{ in.}}{2} + 14.4 \text{ in.} \right) = 43,100 \text{ k-in.}$$

$$\sum M_{pb}^* = (2 \text{ beams})(43,100 \text{ k-in.}) = 86,200 \text{ k-in.}$$

38

### SCWB Example

- Determine if strong-column-weak-beam is satisfied
  - Column Moment

$Z_x = 936 \text{ in}^3$  and  $A = 134 \text{ in}^2$  for W14x455

$$P_{uc} = P_u + 2V_{u \text{ gravity}} = 200 \text{ kips} + 2(30 \text{ kips}) = 260 \text{ kips}$$

$$M_{pc}^* = Z_c \left( F_{yc} - \frac{P_{uc}}{A_g} \right) = (936 \text{ in}^3) \left( 50 \text{ ksi} - \frac{260 \text{ kips}}{134 \text{ in}^2} \right) = 45,000 \text{ k-in.}$$

$$\sum M_{pc}^* = (2 \text{ columns})(45,000 \text{ k-in.}) = 90,000 \text{ k-in.}$$

- Moment Ratio

$$\frac{\sum M_{pc}^*}{\sum M_{pb}^*} = \frac{90,000 \text{ k-in.}}{86,200 \text{ k-in.}} = 1.04 > 1.0$$

**Strong-Column-Weak-Beam is Satisfied.**

39

### Column Panel Zone Shear

- Requirement

*Provisions*  
 §E3.6e

$$R_u \leq \phi R_n$$

$$\phi_v = 1.0$$

$$\frac{M_{f1}}{d_b - t_{bf}} + \frac{V_{uc2}}{d_b - t_{bf}} \leq \frac{M_{f2}}{d_b - t_{bf}}$$

$$\frac{M_{f1}}{d_b - t_{bf}} - \frac{V_{uc1}}{d_b - t_{bf}} \leq \frac{M_{f2}}{d_b - t_{bf}}$$

- Demand (Required Strength) Moment at Face of Column

$$M_f = M_{pr} + V_{ub} S_h$$

Column shear is always opposing beam flange forces.

Column Shear:  $V_c \cong \frac{\sum M_f}{\frac{h_{above}}{2} + \frac{h_{below}}{2}}$

40

### Column Panel Zone Shear

- Design Panel Zone Strength
  - Specification §J10.6
  - If panel zone is considered in frame stability and  $P_r \leq 0.75 P_e$

$$R_n = \underbrace{(0.6F_y)}_{\text{Plastic shear strength}} d_c t_w \underbrace{\left(1 + \frac{3b_f t_{cf}^2}{d_b d_c t_w}\right)}_{\text{Increase for column flanges}} \quad (\text{J10-11})$$

- If  $R_u \leq \phi R_n$  then done.
- If  $R_u > \phi R_n$  then add doubler plates.

- Doubler Plates §E3.6e
  - Get  $\phi R_n$  using:
 
$$t_w = t_{wc} + t_{dp}$$
  - Minimum thickness of column web or doubler plates:
 
$$t \geq \frac{d_z + w_z}{90} \quad d_z = d_b - 2t_{fb} \quad w_z = d_c - 2t_{fc}$$

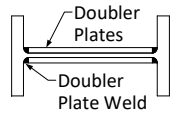

– Also detailing (§E3.6e(3))

41

### Continuity Plates (Column Web Stiffeners)

- Continuity Plates (§E3.6f)
  - Provide continuity plates if either of the following:
    - (a) Required by Section J10 of Specification using force:  $P_f = M_f / (d_b - t_{fb})$   
 reduce by 0.85 if welded web
    - (b) Column flange thickness less than  $t_{lim}$

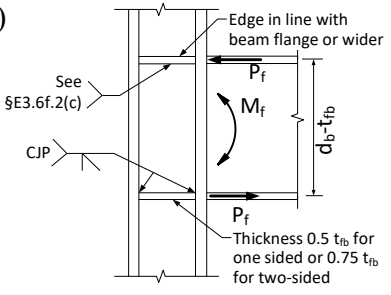

For beam welded to flange of W shape or built-up I

$$t_{lim} = \frac{b_{bf}}{6}$$

- Follow detailing in Specification J10.8 and Seismic Provisions E3.6f.2.

42

### Demand Critical Welds

- Locations (§E3.6a)
  - Welds where inelastic strains are expected.
  - Beam-to-column, column splices, column-to-base plate (with exceptions), others as specified in AISC 358.
- Requirements (§A3.4b and AWS D1.8)
  - Specify demand critical welds on drawings.
  - Filler metals must have high elongation and CVN toughness.

For E70: Elongation > 22%  
 CVN toughness > 20 ft-lb at 0° F



43

### Protected Zone

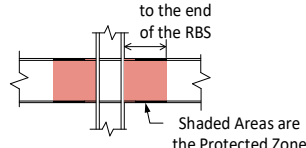
- Locations (AISC 358)
  - Where inelastic strains are expected.
  - Different for each connection (see AISC 358).
- Requirements (§I2.1)
  - No tack welds, holes, erection aids, arc gouging, thermal cutting, headed shear studs.
  - No welded, bolted, screwed, or power-actuated fasteners.
  - Exception: arc spot welds and PAF for decking attachments.

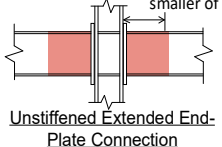

Distance equal to the smaller of d or 3b<sub>f</sub>



44

### Reduced Beam Section (RBS)



- Learning Objective
  - Understand and apply design procedure for one prequalified connection type.
- Prequalification Limits (§5.3)
  - Design to conform to limits of what has been tested.
  - Beams:
    - Maximum of W36
    - Weight  $\leq 302$  lb/ft,
    - $t_f \leq 1.75$  in.
    - Clear span to depth  $\geq 7$  (SMF)
    - W shape or equivalent built-up section
  - Columns:
    - Beam connects to column flange
    - Maximum of W36 or equivalent built-up
    - Up to 24 in. box section up section



45

### Reduced Beam Section (RBS)

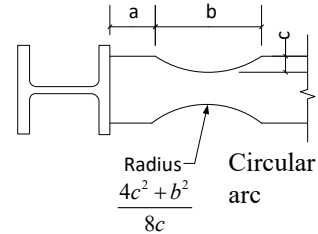
- Special Requirements
  - Allows smaller  $b_f$  in highly ductile member check (§5.3.1(6)).
  - SCWB - Calculates  $M_{pr}$  based on  $Z_{RBS}$  (§5.4(2)).
  - Use elastic drift x 1.1 for  $c = 0.25b_{bf}$ , interpolate for less (§5.8-1).
- Design Procedure (§5.8)
  - Step 1. Choose a, b, c
    - $0.5b_{bf} \leq a \leq 0.75b_{bf}$
    - $0.65d \leq b \leq 0.85d$
    - $0.1b_{bf} \leq c \leq 0.25b_{bf}$

46

### Reduced Beam Section (RBS)

- Design Procedure (§5.8)
  - Step 2. Plastic section modulus at center of RBS,  $Z_{RBS}$ 

$$Z_{RBS} = Z_x - 2ct_{bf}(d - t_{bf})$$
  - Step 3. Calculate probable maximum moment,  $M_{pr}$ 

$$M_{pr} = C_{pr}R_yF_yZ_{RBS}$$
  - Step 4. Calculate shear force at RBS,  $V_{RBS}$ 

$$V_{RBS} = \frac{2M_{pr}}{L_h} + V_{u \text{ gravity}}$$

$L_h$  = distance between plastic hinges (center of RBS's)
  - Step 5. Calculate beam moment at face of column,  $M_f$ 

$$M_f = M_{pr} + V_{RBS}S_h$$

$S_h = a + \frac{b}{2}$



47

### Reduced Beam Section (RBS)

- Design Procedure (§5.8)
  - Step 6. Calculate plastic moment strength of beam (strength at face of column neglecting access holes)
 
$$M_{pe} = R_yF_yZ_x$$
  - Step 7. Check flexural strength of beam at face of column
 
$$M_f \leq \phi_d M_{pe} \quad \phi_d = 1.0 \text{ for ductile limit states}$$
  - Step 8. Check shear strength of beam
 
$$V_u = \frac{2M_{pr}}{L_h} + V_{u \text{ gravity}}$$

Shear Strength per Specification Ch. G



48

### Reduced Beam Section (RBS)



- Design Procedure (§5.8)
  - Step 9. Beam web weld to column flange – detailing per (§5.6)
  - Step 10. Check for continuity plates, design if necessary
  - Step 11. Strong-Column-Weak-Beam requirement
  - Other. Column panel zone shear
  - Other. Detailing requirements in AISC 358



49

### Reduced Beam Section Example

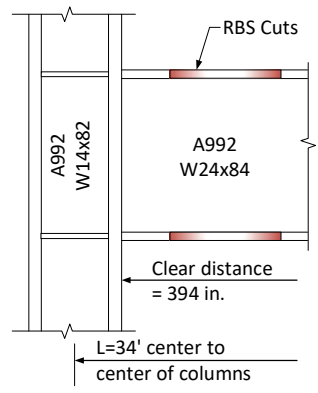
- Step 0 – Prequalification Limits (§5.3)
  - Beams are W36 or smaller, not more than 302 lb/ft, and  $t_{bf} \leq 1.75$  in. **OK**
  - Clear span / depth greater than or equal to 7 (394 in. / 24.1 in. = 16.3) **OK**
  - Sections are highly ductile **OK** (Seismic Manual Table 1-3)
  - Column is less than W36 **OK**



50

### Reduced Beam Section Example

- Step 1 – Trial Values for a, b, c
  - $b_{bf} = 9.02$  in. and  $d = 24.1$  in. for W24x84
  - $[0.5b_{bf} = 4.51 \text{ in.}] \leq a \leq [0.75b_{bf} = 6.76 \text{ in.}]$
  - $[0.65d = 15.7 \text{ in.}] \leq b \leq [0.85d = 20.5 \text{ in.}]$
  - $[0.1b_{bf} = 0.90 \text{ in.}] \leq c \leq [0.25b_{bf} = 2.25 \text{ in.}]$

Select:

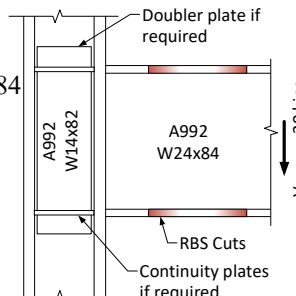
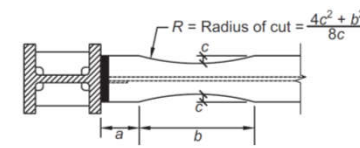

- $a = 6.00$  in.
- $b = 18.0$  in.
- $c = 2.0$  in.

51

### Reduced Beam Section Example

- Step 2 – Calculate  $Z_{RBS}$ 
  - $Z_{RBS} = Z_x - 2ct_{bf}(d - t_{bf})$
  - $Z_{RBS} = 224 \text{ in}^3 - 2(2.0 \text{ in.})(0.77 \text{ in.})(24.1 \text{ in.} - 0.77 \text{ in.}) = 152 \text{ in}^3$
- Step 3 – Calculate  $M_{pr}$ 
  - $C_{pr} = \frac{F_y + F_u}{2F_y} = \frac{50 \text{ ksi} + 65 \text{ ksi}}{2(50 \text{ ksi})} = 1.15 < 1.2$
  - $R_y = 1.1$  Table A3.1 for A992
  - $M_{pr} = C_{pr} R_y F_y Z_{RBS}$
  - $M_{pr} = (1.15)(1.1)(50 \text{ ksi})(152 \text{ in}^3)$
  - $M_{pr} = 9610 \text{ k-in.}$

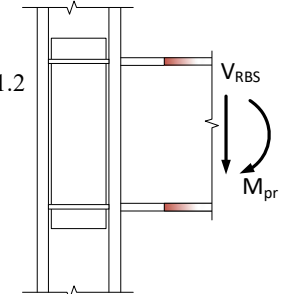
52

### Reduced Beam Section Example

- Step 4 – Shear at Center of RBS

$$S_h = a + \frac{b}{2} = 6 \text{ in.} + \frac{18 \text{ in.}}{2} = 15 \text{ in.}$$

$$L_h = L - d_c - 2S_h$$

$$L_h = 408 \text{ in.} - 14.3 \text{ in.} - 2(15 \text{ in.}) = 364 \text{ in.}$$

$$V_{RBS} = 2M_{pr} / L_h + V_{u \text{ gravity}}$$

$$V_{RBS} = \frac{2(9610 \text{ k-in.})}{364 \text{ in.}} + 30 \text{ kips} = 83 \text{ kips}$$

- Step 5 – Calculate  $M_f$

$$M_f = M_{pr} + V_{RBS} S_h$$

$$M_f = 9610 \text{ k-in.} + (83 \text{ kips})(15 \text{ in.}) = 10,860 \text{ k-in.}$$

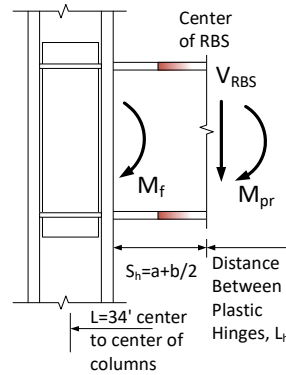

53

### Reduced Beam Section Example

- Step 6 – Calculate Moment Strength at Column Face

$$M_{pe} = R_y F_y Z_x$$

W24x84 beam

$$M_{pe} = (1.1)(50 \text{ ksi})(224 \text{ in}^3)$$

$Z_x = 224 \text{ in}^3$

$$M_{pe} = 12,320 \text{ k-in.}$$

- Step 7 – Check Moment Strength at Face

$$\phi_d M_{pe} \geq M_f \quad \phi_d = 1.0 \text{ for ductile limit states per 358}$$

$$\phi_d M_{pe} = (1.0)12,320 \text{ k-in.} = 12,320 \text{ k-in.}$$

$$[\phi_d M_{pe} = 12,320 \text{ k-in.}] \geq [M_f = 10,860 \text{ k-in.}]$$

**Beam Moment Strength at Column Face is Sufficient**



54

### Reduced Beam Section Example

- Step 8 – Check Beam Shear Strength

$$V_u = V_{RBS} = 83 \text{ kips}$$

– Difference is gravity load between RBS and column face.

– Conservatively include in both.

– Specification Chapter G

$$\frac{h}{t_w} \leq 2.24 \sqrt{\frac{E}{F_y}} \Rightarrow 45.9 \leq 53.9 \quad \text{So, } \phi_v = 1.0 \text{ and } C_{v1} = 1.0$$

$$\phi_v V_n = \phi_v 0.6 F_y A_w C_{v1} = (1.0)(0.6)(50 \text{ ksi})[(24.1 \text{ in.})(0.47 \text{ in.})](1.0)$$

$$\phi_v V_n = 340 \text{ kips} \quad \text{Eqn. (G2-1)}$$

$$[\phi_v V_n = 340 \text{ kips}] \geq [V_u = 83 \text{ kips}]$$

**Beam Shear Strength at Column Face is Sufficient**



55

### Reduced Beam Section Example

- Step 9 – Beam Web to Column Weld

– Beam web to Column Flange is CJP.

– Detailing per (§5.6) – 3/8 in. shear tab as weld backing.

- Step 10 – Continuity Plates see AISC 341 §E3.6f

– Check Specification §J10 with concentrated force,  $P_f$

$$P_f = \frac{0.85 M_f}{d - t_{bf}} = \frac{0.85(10,860 \text{ k-in.})}{24.1 \text{ in.} - 0.77 \text{ in.}} = 396 \text{ kips} \quad \text{Eqn. from AISC 341 E3.6f for welded web}$$

– Also need continuity plates if:  $t_{cf} < t_{c,lim}$   $t_{cf} = 0.855 \text{ in.}$

$$t_{c,lim} = \frac{b_{bf}}{6} = \frac{9.02 \text{ in.}}{6} = 1.50 \text{ in.} \quad t_{cf} \leq t_{c,lim} \quad \text{Continuity Plates are Required}$$

– Follow reqmnts: AISC 341 §E3.6f.2 and AISC 360 § J10.8



56

## Reduced Beam Section Example

- Step 11 – Strong-Column-Weak-Beam
  - Satisfied (not shown here - already worked an example).
- Panel Zone Shear AISC 341 §E3.6e
  - Find that 1/2 in. doubler plate required (not shown here, see example in previous session).
  - Individual layers (web and doubler) minimum thickness:
 
$$t \geq \frac{d_z + w_z}{90} = \frac{(d - 2t_{bf}) + (d_c - 2t_{cf})}{90} = 0.390 \text{ in.}$$

$$[t_{wc} = 0.51 \text{ in}] \geq 0.390 \text{ in.} \quad \text{OK} \quad \text{W14x82 column}$$

$$[t_{doubler} = 0.50 \text{ in}] \geq 0.390 \text{ in.}$$
  - Follow detailing requirements in AISC 341 §E3.6e.3.



57

## Reduced Beam Section Example

- Final Detailing AISC 358 §3.3



58

## SPECIAL CONCENTRICALLY BRACED FRAME CONNECTIONS

Back in AISC 341-16 now

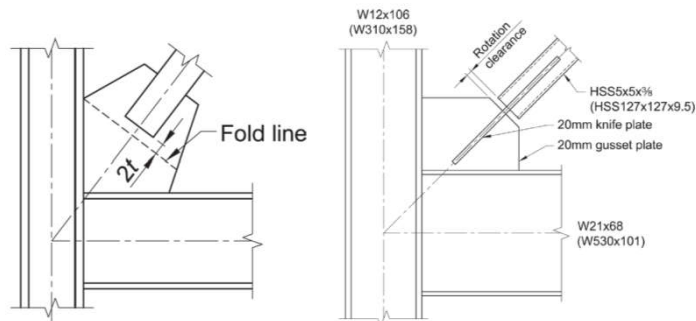

59

## Introduction to SCBF Connections

- Unique Issues for Seismic Bracing Connections
  1. Accommodating rotation in braces – either accommodate rotation or push plastic hinge into brace.
  2. Beam-to-column connections with bracing gussets – design as simple shear or as moment connection.
  3. Designing bracing connections for expected tension strength of braces.
  4. Net section area > gross section area.
  5. Demand critical welds.
  6. Protected zone.

Member requirements not listed.



60

### Accommodating Brace Rotation

- Member requirements (not covered here):
  - Braces in alternating directions – tension and compression.
  - Required strength for columns and beams: combinations of brace tension yielding, buckling strength, brace post-buckling strength.
  - Columns, beams and braces satisfy highly ductile criteria.
- Bracing Connection
  - Ductile mechanism is brace yielding and brace buckling.
  - Must accommodate brace rotation as it buckles without fracture (§F2.6c.3).

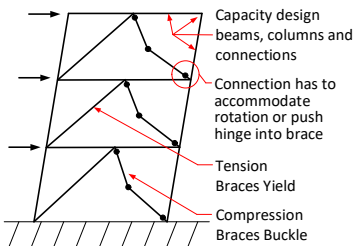

Capacity design beams, columns and connections  
 Connection has to accommodate rotation or push hinge into brace  
 Tension Braces Yield  
 Compression Braces Buckle

61

### Accommodating Brace Rotation

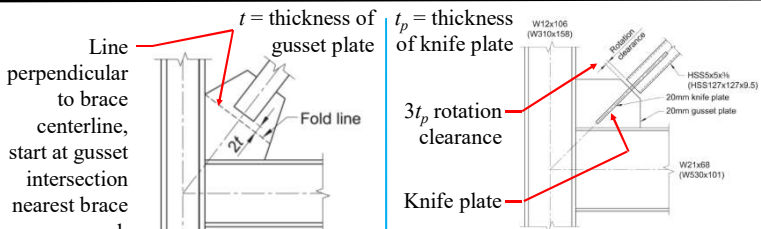

Line perpendicular to brace centerline, start at gusset intersection nearest brace end.

$t$  = thickness of gusset plate

$t_p$  = thickness of knife plate

• 2t Fold Line

- Provide a hinge zone in the gusset plate, width  $2t$ .
- Gusset plate buckling may control gusset thickness.

• Knife Plate Detail

- In-plane brace buckling.
- Provide a hinge zone in the knife plate, width  $3t_p$ .
- More compact connection.

See 3<sup>rd</sup> Ed. SDM Example 5.3.9      See 3<sup>rd</sup> Ed. SDM Example 5.3.11

62

### Accommodating Brace Rotation

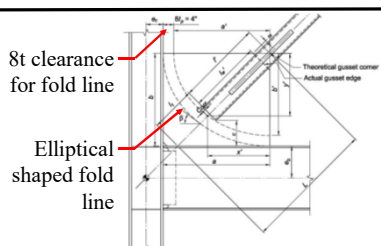

8t clearance for fold line

Elliptical shaped fold line

- Elliptical Fold Line
  - Provide an elliptical hinge zone in the gusset, width  $8t$ .
  - Generally more compact than straight  $2t$  fold line.
- Push plastic hinge into brace
  - Section §F2.6c.3(a) – design brace connection for expected brace flexural strength x 1.1.
  - $1.1R_yM_p$  of brace about the critical buckling direction.
  - Less common than accommodating rotation in gusset per §F2.6c.3(b).

See 3<sup>rd</sup> Ed. SDM Example 5.3.10

63

### Beam-to-Column Connections

- §F2.6b - Option (a)
  - Design as simple connection. Allow rotation per *Specification* §B3.4a.
  - Commentary shows three options:

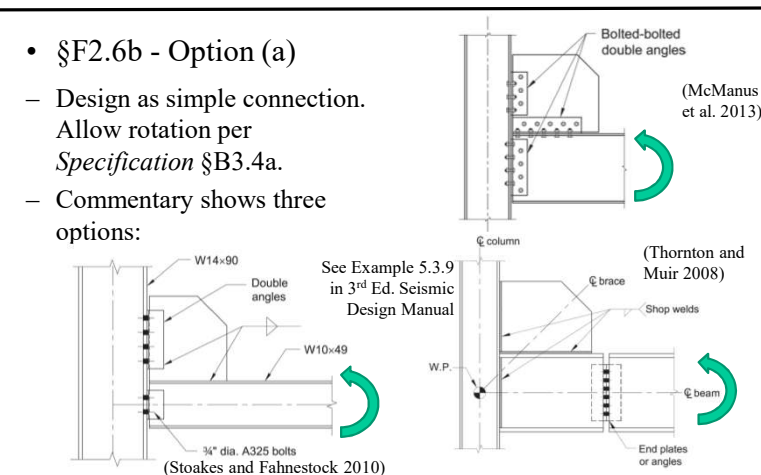

Bolted-bolted double angles (McManus et al. 2013)

Double angles (Thornton and Muir 2008)

Shop welds

End plates or angles

W14x90

W10x49

3/4" dia. A325 bolts (Stoakes and Fahnestock 2010)

See Example 5.3.9 in 3<sup>rd</sup> Ed. Seismic Design Manual

64

### Beam-to-Column Connections

- §F2.6b - Option (b)
  - Design as moment connection.
  - Design for either expected flexural strength of beam x 1.1, or 1.1 times sum of expected flexural strength of columns framing into joint.
  - Combine with demands from brace and collector.
  - See Example 5.3.11 in 3<sup>rd</sup> Ed. Seismic Design Manual.

*Example of loads associated with required moment  
 3<sup>rd</sup> Ed. SDM Ex. 5.3.11*

65

### Beam-to-Column Connections

- §F2.6b - Option (c)
  - Detail similar to WUF-W, see §E1.6b(c).
  - Welds per AISC 358 with CJP at flanges.
  - Special weld access hole detailing.
  - Beam web to column welded or single plate bolted.
  - Continuity plates per E3.6f.

66

### Connection Demands - Tension

- Required Tensile Strength §F2.6c.1
  - $T_u = R_y F_y A_g$   $A_g$  = gross area of brace
  - This load does not apply to brace net section check.
  - Can be limited by the max force that can be transferred to brace (e.g. foundation uplift) – not common and not a good design approach.
  - For standard size holes, don't need to design as slip critical. For oversized holes, design demand for slip can be limited by overstrength loads.

67

### Connection Demands - Compression

- Required Compression Strength, §F2.6c.2
  - Design connection for expected brace strength in compression (see below).
  - Does not need to exceed  $R_y F_y A_g$ .
  - Length used in buckling calculation not greater than brace end to brace end.

$$P_u = \frac{F_{cre} A_g}{0.877}$$

$F_{cre} = F_{cr}$  from Specification Ch. E, but using  $R_y F_y$  as yield

68

### Connection Demands - Flexure

- Required Flexural Strength, §F2.6c.3
  - If not detailing connection to accommodate rotation.
  - $M_u = 1.1 R_y M_p$  of brace
- Combination of Tension, Compression, and Flexure
  - Permitted to consider loads independently, no interaction.
  - See beginning of §F2.6c.

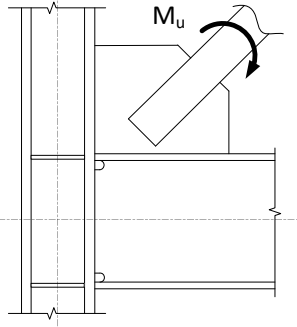



69

### Overview of Limit States

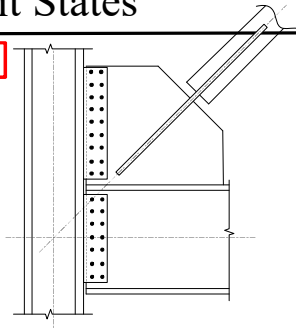
1. Brace net section fracture - Unique to SCBF
2. Brace to knife plate weld
3. Knife plate tension yielding, net section rupture, compression buckling
4. Knife plate to gusset weld
5. Gusset tension yield on Whitmore section, compression buckling
6. Gusset at bolts – tension yield, net section tension rupture, shear rupture, block shear
7. Gusset to beam weld
8. Shear transfer at single plate connections: (bolt shear, bearing and tear-out)
9. Single plates - tension yield, net section tension or shear rupture, block shear
10. Single plates to column weld
11. Beam web local yielding and crippling / stiffeners if necessary
12. Column web local yielding and crippling / stiffeners if necessary





70

### Connection Design for Actual Location of Forces

Need to consider actual location of forces applied in a connection to get correct shear and moment in the member

“Chevron Effect”  
 Not Specific to Seismic

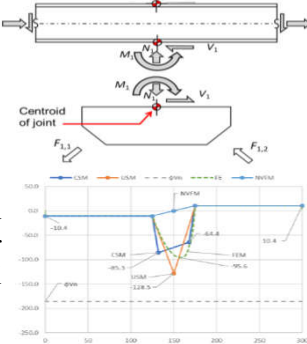
Localized beam shear [from Sabelli et al. (2020)]



References:

- Fortney, P.J. and Thornton, W.A. (2015), “The Chevron Effect – Not an Isolated Problem.” *AISC Engineering Journal*, 2015, Qtr 2.
- Example 5.3.8 in the 3rd Edition of the Seismic Design Manual
- Soon to be released paper: Sabelli, R., Saxey, B., and Arber, L., “Design for Local Web Shear at Brace Connections: Full-Height and Midspan Gussets.” *AISC Engineering Journal*.
- Sabelli, R., Saxey, B., Richards (2020) “The ‘Chevron Effect’ In Web Shear At Midspan Gussets: A Comparison of Design Methods and FEM Modeling”, 17WCEE Conference in Sendai Japan



71

### Net Section Fracture Requirement

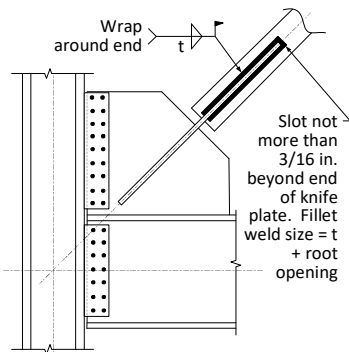
- Brace Net Area, §F2.5b.(c)
  - Brace effective net area not less than gross area.
  - For knife plate connection, slot in brace can be close to end of knife plate.
  - AWS D1.1-15 §5.21 says root opening not greater than 3/16 in. and if over 1/16 in. increase legs of fillet for root opening size.



*One approach for making net area ≥ gross area*

72

### Net Section Fracture Requirement

- Brace Net Area, §F2.5b.(c)

If using reinforcement :

- Size reinforcement so that  $UA_n > A_g$ .
- Reinforcement should have yield stress at least equal to yield stress of brace.
- Weld to develop reinforcement *expected* strength on both sides of reduced section.

73

### Demand Critical Welds

- Demand Critical Welds §F2.6a
- Groove welds at column splices.
- Welds at column-to-base plate connections (unless plastic hinging near base plate is prevented and no net uplift).
- Welds at beam-to-column connection if using §F2.6b(c) prescriptive moment connection.

74

### Protected Zone

- Protected Zone Locations §F2.5c
- Center 1/4 of brace length.
- Within  $d$  of the braced connection.
- Connection region.
- Limitations §D1.3 and §I2.1
- No tack welds, holes, erection aids, arc gouging, thermal cutting, headed shear studs.
- No welded, bolted, screwed, or power-actuated fastener attachments.

Figures C-F2.14 and C-F2.15 in AISC 341

75

### SCBF - Example

- Do the Following:
  - Calculate the gusset plate required tension and compression strength.
  - Design the gusset plate thickness and fold line dimension.
  - Check the brace net section and design reinforcement.

76

### SCBF - Example

1a. Calculate brace connection required tension strength

HSS 6.875x0.500 A500 Gr. B  
 $A_g = 9.36 \text{ in}^2$ ,  $F_y = 42 \text{ ksi}$ ,  $R_y = 1.4$  (Table A3.1)

$$P_{u-tens} = R_y F_y A_g$$

$$P_{u-tens} = 1.4(42 \text{ ksi})(9.36 \text{ in}^2)$$

$P_{u-tens} = 550 \text{ kips}$



77

### SCBF - Example

1b. Calculate brace connection required compression strength - use AISC 360 Ch. E with  $F_y = R_y F_y$

$$L_b = 144 \text{ in.}, K = 1.0, r = 2.27 \text{ in.} \quad \frac{KL_b}{r} = 63.4$$

$$\left[ \frac{KL_b}{r} = 63.4 \right] \leq \left[ 4.71 \sqrt{\frac{E}{R_y F_y}} = 4.71 \sqrt{\frac{29,000 \text{ ksi}}{1.4(42 \text{ ksi})}} = 105 \right]$$

So use Eq. E3-2 in AISC 360

$$F_e = \frac{\pi^2 E}{\left( \frac{KL_b}{r} \right)^2} = \frac{\pi^2 (29,000 \text{ ksi})}{63.4^2} = 71.2 \text{ ksi}$$

78

### SCBF - Example

1b. Calculate brace connection required compression strength - use AISC 360 Ch. E with  $F_y = R_y F_y$

$$F_{cre} = \left[ 0.658 \frac{R_y F_y}{F_e} \right] R_y F_y = \left[ 0.658 \frac{(1.4)(42 \text{ ksi})}{(71.2 \text{ ksi})} \right] (1.4)(42 \text{ ksi})$$

$$F_{cre} = 41.6 \text{ ksi}$$

$$P_{u-comp} = \min \left\{ \frac{F_{cre} A_g}{0.877}, R_y F_y A_g \right\}$$

$P_{u-comp} = 444 \text{ kips}$

$$P_{u-comp} = \min \left\{ \frac{(41.6 \text{ ksi})(9.36)}{0.877}, 550 \text{ kips} \right\} = 444 \text{ kips}$$

79

### SCBF - Example

2a. Tension Yield on Gusset Whitmore Section

Gusset plate width at end of brace is given as  $w_{pa} = 28 \text{ in.}$

Calculate Whitmore width:  $w_{pw}$

$$w_{pw} = 6.875 \text{ in.} + 2(27 \text{ in.}) \tan(30^\circ)$$

$$w_{pw} = 38.1 \text{ in.}$$

Plate width to use:

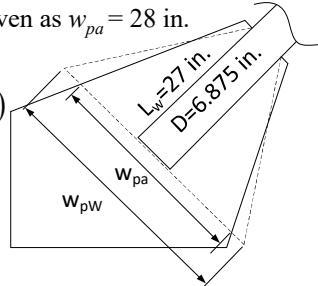
$$w_p = \min \{ w_{pa}, w_{pw} \} = 28.0 \text{ in.}$$

Try 5/8 in. gusset plate

$$\phi R_n = 0.9 F_y t_p w_p = 0.9(50 \text{ ksi})(5/8 \text{ in.})(28.0 \text{ in.}) = 788 \text{ kips}$$

$[\phi R_n = 788 \text{ kips}] \geq [P_{u-tens} = 550 \text{ kips}] \quad \text{OK}$



80

### SCBF - Example

**2b. Block Shear on Gusset**    Trying a 5/8 in. gusset

$$A_{nt} = D t_p = (6.875 \text{ in.})(5/8 \text{ in.}) = 4.30 \text{ in}^2$$

$$A_{gv} = 2L_w t_p = 2(27 \text{ in.})(5/8 \text{ in.}) = 33.8 \text{ in}^2$$

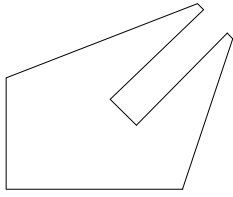
$$A_{nv} = A_{gv}$$

Because  $A_{nv} = A_{gv}$ , shear yield controls

$$\phi R_n = 0.75(0.6F_{yp}A_{gv} + U_{bs}F_{up}A_{nt})$$

$$\phi R_n = 0.75[0.6(50 \text{ ksi})(33.8 \text{ in}^2) + 1.0(65 \text{ ksi})(4.30 \text{ in}^2)]$$

$[\phi R_n = 970 \text{ kips}] \geq [P_{u-tens} = 550 \text{ kips}] \quad \text{OK}$



81

### SCBF - Example

**2c. Gusset Plate Buckling**    Trying a 5/8 in. gusset

$$r_p = \frac{t_p}{\sqrt{12}} = \frac{5/8 \text{ in.}}{\sqrt{12}} = 0.18 \text{ in.}$$

$$\left[ \frac{KL_b}{r_p} = \frac{(0.65)(17)}{(0.18)} = 61 \right] \leq 4.71 \sqrt{\frac{E}{F_y}}$$

$$F_e = \frac{\pi^2 E}{\left( \frac{KL_b}{r} \right)^2} = 76.3 \text{ ksi}$$

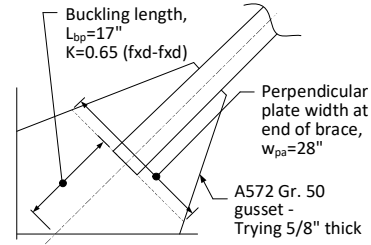
$$F_{cr} = \left[ 0.658 \frac{F_y}{F_e} \right] F_y = 38.0 \text{ ksi}$$

Buckling length,  $L_{bp}=17"$   
 $K=0.65$  (fxd-fxd)  
 Perpendicular plate width at end of brace,  $w_{ps}=28"$   
 A572 Gr. 50 gusset - Trying 5/8" thick

$$\phi P_n = 0.9 F_{cr} w_{ps} t_p = 0.9(38.0 \text{ ksi})(28 \text{ in.})(5/8 \text{ in.})$$

$[\phi R_n = 599 \text{ kips}] \geq [P_{u-comp} = 444 \text{ kips}] \quad \text{OK}$



82

### SCBF - Example

**3a. Brace Effective Net Section without Reinforcement**

HSS 6.875x0.500,  $t_{des}=0.465 \text{ in.}$     Slot 1/8 in. larger than plate

Trying a 5/8 in. gusset

$$A_{n-orig} = A_g - 2(t_p + 1/8 \text{ in.})t_{des}$$

$$A_{n-orig} = 9.36 \text{ in}^2 - 2(5/8 \text{ in.} + 1/8 \text{ in.})0.465 \text{ in.}$$

$$A_{n-orig} = 8.66 \text{ in}^2$$

*AISC 360 Table D3.1 Case 5*

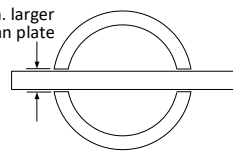

$U = 1.0$  because  $L > 1.3D$      $27.0 \text{ in.} > (1.3)(6.875 \text{ in.})$

$$A_{e-orig} = 1.0 A_{n-orig} = 8.66 \text{ in}^2 < A_g = 9.36 \text{ in}^2$$

→ Need reinforcement



83

### SCBF - Example

**3b. Brace Effective Net Section with Reinforcement**

Try 1 in. x 1 in. reinforcement,  $t_r = 1.0 \text{ in.}$   
 Can't use  $U = 1.0$  now. Calculate  $U$ :

$$\bar{x}_{ring} \cong \frac{D}{\pi} = \frac{6.875 \text{ in.}}{\pi} = 2.19 \text{ in.}$$

$$\bar{x}_{reinf} = \frac{D}{2} + \frac{t_r}{2} = 3.94 \text{ in.} \quad \text{AISC 360 Table D3.1 Case 2}$$

$$\bar{x} = \frac{\bar{x}_{ring} A_{ring} + \bar{x}_{reinf} A_{reinf}}{A_{ring} + A_{reinf}} = 2.50 \text{ in.}$$

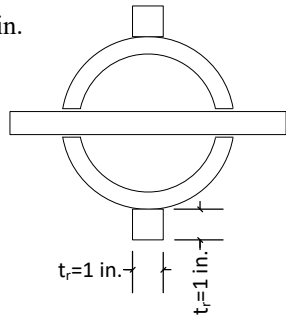
$$U = 1 - \frac{\bar{x}}{L_w} = 1 - \frac{2.50 \text{ in.}}{27.0 \text{ in.}} = 0.91$$

$t_r = 1 \text{ in.}$      $t_r = 1 \text{ in.}$

HSS6.875x0.500  
 $D = 6.875 \text{ in.}$



84



### SCBF - Example

**3b. Brace Effective Net Section with Reinforcement**

Try 1 in. x 1 in. reinforcement,  $t_r = 1.0$  in.

$$A_e = U(A_{n-orig} + 2t_r^2)$$

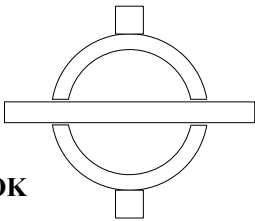
$$A_e = 0.91(8.66 \text{ in}^2 + 2(1 \text{ in.})^2) = 9.68 \text{ in}^2$$

$$[A_e = 9.68 \text{ in}^2] \geq [A_g = 9.36 \text{ in}^2] \quad \text{OK}$$



85

### SCBF - Example

**3c. Length of Reinforcement**

Expected strength of the reinforcement



$$R_{ey} = t_r^2 R_{yr} F_{yr} = (1.0 \text{ in}^2)(1.1)(50 \text{ ksi}) = 55.0 \text{ kips}$$

Try 8 in. long 3/16 in. welds

$$\phi R_n = 2L_{wr} \left( \frac{t_{wr}}{16} \right) 1.392$$

$$\phi R_n = 2(8 \text{ in.})(3 \text{ sixteenths}) 1.392$$

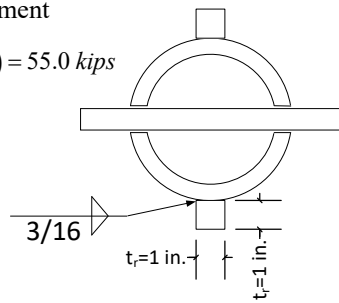
$$\phi R_n = 66.8 \text{ kips}$$

$$[\phi R_n = 66.8 \text{ kips}] \geq [R_{ey} = 55.0 \text{ kips}] \quad \text{OK}$$



86

### SCBF - Example

**Fold Line and Final Detail**

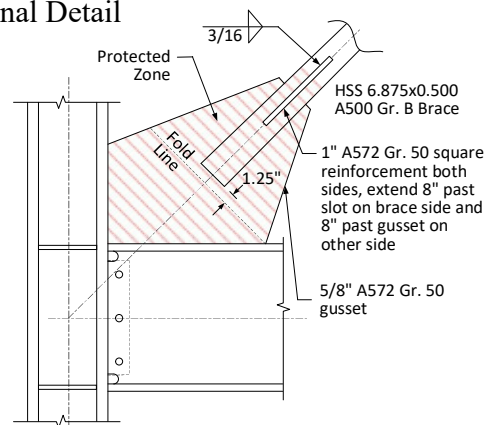
Fold Line:  
 $2t = 2(5/8 \text{ in.})$   
 $2t = 1.25 \text{ in.}$



HSS 6.875x0.500  
 A500 Gr. B Brace

1" A572 Gr. 50 square  
 reinforcement both  
 sides, extend 8" past  
 slot on brace side and  
 8" past gusset on  
 other side

5/8" A572 Gr. 50  
 gusset



87

End of Session 3  
 Thank You for  
 Attending

Next Up



88

## Next Session

---

- March 11, 2020 Bracing Connections

### TOPICS

- Light Bracing Connections
- Heavy Bracing Connections
- Uniform Force Method



89

AISC | Questions?



Smarter.  
Stronger.  
Steel.

## Single-Session Registrants

---

### CEU / PDH Certificates

- You will receive an email on how to report attendance from:  
[registration@aisc.org](mailto:registration@aisc.org).
- Be on the lookout: Check your spam filter! Check your junk folder!
- Completely fill out online form. Don't forget to check the boxes next to each attendee's name!



Smarter.  
Stronger.  
Steel.

## Single-Session Registrants

---

### CEU / PDH Certificates

- Reporting site (URL will be provided in the forthcoming email).
- Username: Same as AISC website username.
- Password: Same as AISC website password.



Smarter.  
Stronger.  
Steel.

## 4-Session Registrants

### CEU / PDH Certificates

One certificate will be issued at the conclusion of the course.



## 4-Session Registrants

### Attendance and PDH Certificates

- You have two options to receive credit for a given session.
  - Option 1: Watch the live session. Credit for live attendance will be displayed on the Course Resources table within two days of the session.
  - Option 2: Watch the recording and pass the associated quiz.

### Videos and Quizzes

- For each session, find access by the end of the day, Friday, after the live air date. (An email will be sent from [webinars@aisc.org](mailto:webinars@aisc.org).)
- Quiz scores are displayed in the Course Resources table.

### Distribution of Certificates

All certificates will be issued after the course is completed. Only the registrant will receive a certificate for the course.



## 4-Session Registrants

### Course Resources

Find all your handouts, quizzes and quiz scores, recording access, and attendance information in one place!



## 4-Session Registrants

### Course Resources

Go to [www.aisc.org](http://www.aisc.org) and sign in.

EDUCATION PUBLICATIONS STEEL SOLUTIONS CENTER AWARDS AND COMPETITIONS TECHNICAL RESOURCES

AMERICAN INSTITUTE OF STEEL CONSTRUCTION  
FOUNDED 1921

USERNAME  
Enter your username

PASSWORD  
Enter your password

Remember Me

LOGIN

Forgot Username? Forgot Password?

DON'T HAVE AN ACCOUNT?  
My AISC allows you to access Engineering Journal articles and Design Guides you have downloaded from the bookstore.

REGISTER NOW

## 4-Session Registrants

### Course Resources

Go to [www.aisc.org](http://www.aisc.org) and sign in.

**IN THIS SECTION**

- Edit Profile
- My Downloads
- My Pending Orders
- My Events
- Order History
- Course History
- Course Resources**

**MyAISC**

**MY PROFILE**  
 Update your contact and address information.  
[EDIT PROFILE](#)

**MY PURCHASED DOWNLOADS**  
 Access articles and documents that you have purchased.  
[VIEW DOWNLOADS](#)

**MY COURSE RESOURCES**  
 View online resources for Night School and Live Webinar package registrations.  
[VIEW RESOURCES](#)

## 4-Session Registrants

### Course Resources

Event	Start Date
Seismic Design of Steel	3/17/2020 12:00:00 AM
4-Session Package Design of Facade Attachments	5/9/2018 1:00:00 PM
101.20.8-Session Package Night School 20 - Fundamentals of Connection Design	2017/2017 7:00:00 PM
101.20.8-Session Package Night School 20 - Seismic Design of Steel	2/5/2018 7:00:00 PM
101.27.4-Session Package Night School 22 - Design of Facade Attachments	1/5/2018 7:00:00 PM
101.28.8-Session Package Night School 18 - Steel Construction: NF-T6 Towering Out	10/15/2018 7:00:00 PM
101.28.8-Session Package Night School 18 - Connection Design	2/4/2018 7:00:00 PM
101.27.4-Session Package Night School 20 - Classical Methods of Structural Analysis	6/3/2018 7:00:00 PM
8-Session Package Seismic Design of Steel - Connections & Details	7/10/2018 1:00:00 PM

## 4-Session Registrants

### Course Resources

**Design of Facade Attachments**

**4-SESSION PACKAGE RESOURCES**

Event	Date	Handouts	Video	Quiz	Attendance
41. Facade Fundamentals	N/A	Handouts	Video	Quiz	N/A
U1. Facade Attachments Part 1	May 9 2018 1:30PM EDT	Handouts	Available 05/11/2018 9:00PM EDT	Available 05/11/2018 9:00 PM EDT	Pending
U2. Facade Attachments Part 2	May 16 2018 1:30PM EDT	Handouts	Available 05/18/2018 9:00PM EDT	Available 05/18/2018 1:00 PM EDT	Pending
U3. Facade Attachments - Building Lateral Drifts	May 23 2018 1:30PM EDT	Handouts	Available 05/25/2018 9:00PM EDT	Available 05/25/2018 5:00 PM EDT	Pending
Total Exam	N/A			Available 5/27/2018 5:00 PM EDT	

**AISC | Thank you.**