

AISC Live Webinars

Thank you for joining our live webinar today.
We will begin shortly. Please standby.

Design of Strengthening for Existing Steel Members
December 10, 2020



AISC Live Webinars

Today's live webinar will begin shortly. Please stand by.

Today's audio will be broadcast through the internet. Please be sure to turn up the volume on your speakers.

Please type any questions or comments through the chat feature in the left portion of your screen.



AISC Live Webinars

AIA Credit

AISC is a Registered Provider with The American Institute of Architects Continuing Education Systems (AIA/CES). Credit(s) earned on completion of this program will be reported to AIA/CES for AIA members. Certificates of Completion for both AIA members and non-AIA members are available upon request.

This program is registered with AIA/CES for continuing professional education. As such, it does not include content that may be deemed or construed to be an approval or endorsement by the AIA of any material of construction or any method or manner of handling, using, distributing, or dealing in any material or product.

Questions related to specific materials, methods, and services will be addressed at the conclusion of this presentation.



AISC Live Webinars

Copyright Materials

This presentation is protected by US and International Copyright laws. Reproduction, distribution, display and use of the presentation without written permission of AISC is prohibited.

© The American Institute of Steel Construction 2020

The information presented herein is based on recognized engineering principles and is for general information only. While it is believed to be accurate, this information should not be applied to any specific application without competent professional examination and verification by a licensed professional engineer. Anyone making use of this information assumes all liability arising from such use.



AISC Live Webinars

Course Description

Design of Strengthening for Existing Steel Members
December 10, 2020

This webinar presents practical design guidelines for strengthening existing steel beams, columns, and connections. Focusing on gravity framing systems, relevant code requirements of the International Existing Building Code and the 2016 AISC *Specification for Structural Steel Buildings* will be discussed. In addition, the seminar will review reference standards such as AISC *Design Guide 15, Rehabilitation and Retrofit*, 2nd Edition that can be used to determine material strengths and section properties of older steel members. Several reinforcing schemes will be presented, including welded plate reinforcing, introduction of composite action, and post-tensioning. Considerations for welding to historic steel, including members that are loaded at the time of welding, will be discussed. Using the design procedures of the 2016 AISC *Specification*, this webinar will present detailed strengthening examples that participants can reference in their design practice.



AISC Live Webinars

Learning Objectives

- Identify motivations for strengthening existing structural steel.
- Name the relevant standards to follow when designing structural steel reinforcement.
- Explain the issues to consider when evaluating the capacity of existing steel structures.
- Describe typical steel reinforcement solutions.



Design of Strengthening for Existing Steel Members



Joseph S. Schuster
Vice President
Thornton Tomasetti
Newark, NJ

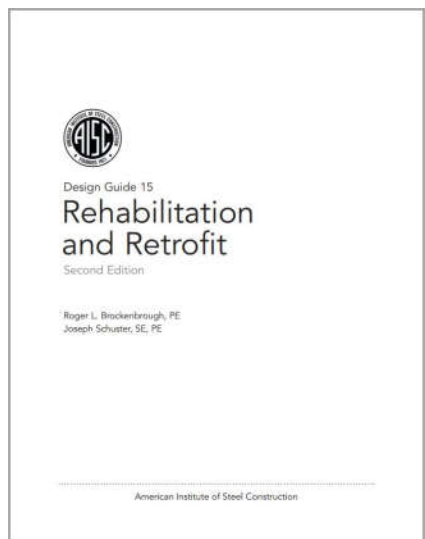
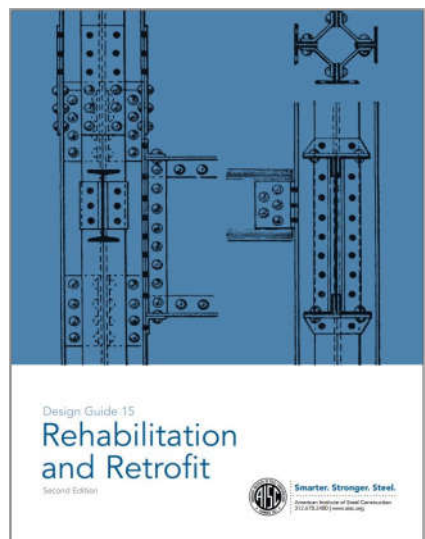

Course Agenda

- Why Strengthen?
- Code Requirements
 - IEBC
 - AISC *Specification* Appendix 5
- Evaluation of Existing Steel
 - Determining Material Properties
 - Determining Dimensional Information
- Strengthening Schemes and Design Examples
 - Beams
 - Columns
 - Connections



9

Why Strengthen?

- Change in Member Loading
 - Building expansion



Source: Workshop APD



10

Why Strengthen?

- Change in Member Loading
 - Building expansion
 - Change in occupancy (increased live loads)



50 psf



100 psf



11

Why Strengthen?

- Change in Member Loading
 - Building expansion
 - Change in occupancy (increased live load)
 - Change of finishes/equipment (increased dead load)

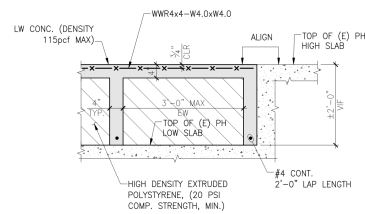

Source: "Storage Cabinet Design," thelifefriars.info



12

Why Strengthen?

- Change in Member Loading
 - Building expansion
 - Change in occupancy (increased live load)
 - Change of finishes/equipment (increased dead load)
 - Reframing (new openings, column removal)

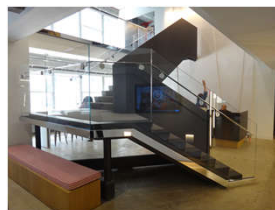
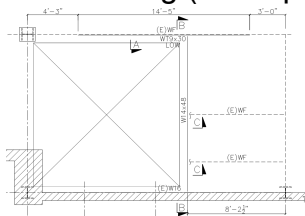

13

Why Strengthen?

- Repairs
 - Failures due to accidents (fire, impact)



14

Why Strengthen?

- Repairs
 - Failures due to accidents (fire, impact)
 - Reduction in cross section (corrosion)



Source: Federal Highway Administration, Arlington Memorial Bridge



15

Why Strengthen?

- Repairs
 - Failures due to accidents (fire, impact)
 - Reduction in cross section (corrosion)
 - Seismic retrofit
 - Not covered here. See ASCE 41 and FEMA 547.



16

Code Requirements



2016 AISC Specification Appendix 5 Evaluation of Existing Structures

5.1 GENERAL PROVISIONS

These provisions shall be applicable when the evaluation of an existing steel structure is specified for (a) verification of a specific set of design loadings or (b) determination of the available strength of a load resisting member or system. The evaluation shall be performed by [structural analysis \(Section 5.3\)](#), by [load tests \(Section 5.4\)](#), or by a combination of structural analysis and load tests, when specified in the contract documents by the engineer of record.



17

Code Requirements

General Design Procedure

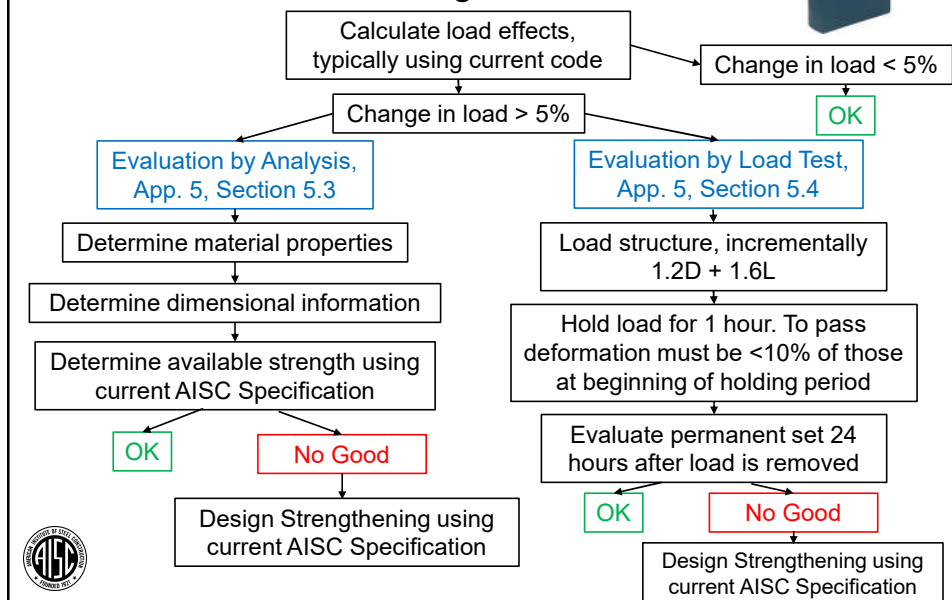

Code Requirements



2016 AISC *Specification*

Appendix 5

Evaluation of Existing Structures

Evaluation by Analysis

5.3.2 Strength Evaluation

Forces (load effects) in members and connections shall be determined by structural analysis applicable to the type of structure evaluated. The load effects shall be determined for the loads and factored **load combinations stipulated in Section B2.**

The available strength of members and connections shall be determined from applicable provisions of Chapters B through K **of this Specification.**



19

Material Properties



2016 AISC *Specification*

Appendix 5

Evaluation of Existing Structures

5.2. MATERIAL PROPERTIES

1. Determination of Required Tests

The EOR shall determine the specific tests that are required from Sections 5.2.2 through 5.2.6 and specify the locations where they are required. Where available, the use of applicable project records is permitted to reduce or eliminate the need for testing.

**ALWAYS ASK FOR ORIGINAL DRAWINGS BEFORE
PROCEEDING WITH PROBES AND TESTING.**



20



Material Properties



- **Tensile Properties, F_u and F_y**
 - AISC *Specification App. 5* Section 5.2.2
 - EOR to determine required number of tests
 - Where available, project records may be used to establish material properties
 - Test samples in accordance with ASTM A370



Material Properties



- **Tensile Properties, F_u and F_y**
 - Year of construction can be used as starting point

Table 1
ASTM and AISC History

Year	Standard	ASTM T.S. (ksi)	Y.P. (ksi)	AISC Basic Working Stress
1901	A9 Buildings	60-70	0.5 T.S.	—
1909	A9 Buildings	55-65	0.5 T.S.	—
1923	A9 Buildings	55-65	0.5 T.S.	18
1924	A9 Buildings	55-65	0.5 T.S.	18
1933	A9 Buildings	60-72	0.5 T.S. (not less than 33)	18
1936	A9 Buildings	60-72	0.5 T.S. (not less than 33)	20
1939	A7 Buildings (and Bridges)	60-72	0.5 T.S. (not less than 33)	20
1942	A7 WPB Emergency Standards			
	A7	60-72	0.5 T.S. (not less than 33)	20
1960	A36 (Supp.)	58-80	36	22
	A7	60-72	0.5 T.S. (not less than 33)	20
1963	A36	58-80	36	$0.6F_y$
	A440	varied	varied	$0.6F_y$
	A441	varied	varied	$0.6F_y$
	A242	varied	varied	$0.6F_y$
1967	A7 discontinued			
	A36	58-80	36	$0.6F_y$
1968	A572	varied	varied	$0.6F_y$
	A588	varied	varied	$0.6F_y$

$F_u = 55 \text{ ksi}, F_y = 27.5 \text{ ksi}$

$F_u = 60 \text{ ksi}, F_y = 30 \text{ ksi}$

$F_u = 58 \text{ ksi}, F_y = 36 \text{ ksi}$



Source: Gustafson, Kurt, "Evaluation of Existing Structures," *Modern Steel Construction*, Feb 2007



Material Properties



- **Chemical Composition (Weldability)**

- AISC Specification App. 5 Section 5.2.3

- Determine chemical composition (ASTM A751) and prepare welding procedure specification per AWS D1.1

- Steels with carbon equivalent less than 0.45 are generally weldable

$$CE = C + \frac{(Mn + Si)}{6} + \frac{(Cr + Mo + V)}{5} + \frac{(Ni + Cu)}{15}$$

Principle Elements	ASTM A36 Limit	Sample 1	Sample 2
Carbon	<0.26	0.18	0.19
Manganese	0.8-1.2	0.57	0.60
Silicon	0.15-0.4	0.12	0.17
Chromium	n/a	0.04	0.04
Molybdenum	n/a	0.01	0.03
Vanadium	n/a	0.00	0.00
Nickel	n/a	0.07	0.07
Copper	>0.2	0.10	0.16
Impurities			
Sulfur	<0.04	0.028	0.030
Phosphorus	<0.05	0.034	0.030
CE		0.32	0.35



23

Material Properties

- **Weldability of Historic Steels**

- A7 and A9 (1901-1963) need to be evaluated on case-by-case basis
- ASTM A7 and A9 Specification covered min. strength but no limits on carbon content
- Common weldability concerns:
 - Too much carbon: high hardenability, low ductility
 - Too much phosphorus: increased brittleness, weld cracking
 - Too much sulfur: porous welds



24

Material Properties

• Welding to Existing Steel

- Preheating Recommendations:

Carbon Equivalent	Preheat Temperature
0 to 0.45	Preheating Optional
0.45 to 0.60	200°F - 400°F, use low-hydrogen electrode

- For carbon equivalent > 0.45, perform “tab plate” trial test to confirm weldability

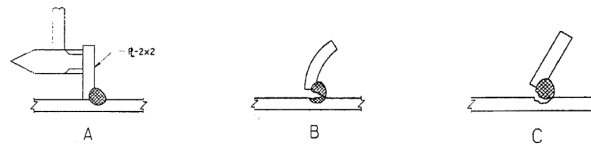

- Additional Resources:

- “Field Welding to Existing Steel Structures” (Ricker, 1988)
- AWS D1.7 *Guide for Strengthening and Repairing Existing Structures*
- AISC Design Guide 21, 2nd Edition, Section 5.4.5

25

Material Properties

• Welding to Existing Steel

- Steel begins to lose strength above 650°F
 - Consider reduced strength when welding to loaded members and provide shoring if needed
- Weld design, best practice:
 - Use fillet welds
 - Use smallest weld size adequate for loads
 - Use intermittent welds
 - Avoid overhead welding (slower deposit rate)
 - Avoid welds across stress lines



26

Material Properties



- **Bolts and Rivets**
 - AISC *Specification* **App. 5** Section 5.2.6

- Look for markings
- Acceptable assumptions:
 - Bolts: ASTM A307
 - Rivets: ASTM A502, Grade 1

A307	
A325	
A490	
A449	

- In rare cases, test in accordance with ASTM F606



27

Dimensional Data



2016 AISC *Specification* **Appendix 5** Evaluation of Existing Structures

5.3. EVALUATION BY STRUCTURAL ANALYSIS

1. Dimensional Data

All dimensions used in the evaluation, such as spans, column heights, member spacings, bracing locations, cross-section dimensions, thicknesses, and connection details, shall be determined from a field survey. Alternatively, when available, it is permitted to determine such dimensions from applicable project design or shop drawings with field verification of critical values.

**ALWAYS ASK FOR ORIGINAL DRAWINGS BEFORE
PROCEEDING WITH PROBES AND TESTING.**



28

Dimensional Data

- Use original drawings (when available)



8B17: 8 in. deep, 17 lbs/ft



29



Dimensional Data

- Determine or confirm member sizes, spans, and connection details with probes
 - Typically d , b_f , and t_f are sufficient to determine member size
 - Use tables in DG 15 to determine section properties
 - Measure slab thickness, etc. for determination of dead loads



30



Dimensional Data

* Source Reference Number is found in the following tables: Table 5-3.3a, Table 5-3.3b, Table 5-3.3c, Table 5-3.3d and Table 5-3.3e.

Designation	Source Reference Number*	Table 5-3.1. Dimensions and Properties—Steel Sections 1887-1952										Table 5-3.1 (continued). Dimensions and Properties—Steel Sections 1887-1952															
		Wt. per ft.	Area	Depth	Web Thickness	Flange Width	Average Flange Thickness	Distance	Distance	Designation	Compact Section Criteria				Stability Properties						Plate Moduli						
		lb	in. ²	in.	in.	in.	in.	in.	in.	in.	λ_{p1}	λ_{p2}	λ_{p3}	λ_{p4}	λ_{p5}	λ_{p6}	λ_{p7}	λ_{p8}	λ_{p9}	λ_{p10}	λ_{p11}	λ_{p12}	λ_{p13}	λ_{p14}	λ_{p15}	λ_{p16}	
B12	8	36.0	10.58	12.25	0.300	6.555	0.545	10.190	0.030	B12	0.01	34.0	28	2742	2389	231.8	40.0	5.18	22.7	6.8	1.40	11.1	11.1				
CB122	17	34.0	9.99	12.00	0.375	6.835	0.431	10.335	0.844	CB122	1.20	27.8	—	2470	4870	208.1	39.8	4.88	21.2	4.3	1.35	10.8	8.8				
12W6	24	32.5	9.54	12.00	0.310	6.570	0.556	10.294	0.853	12W6	1.20	23.7	88	1620	3462	208.1	39.7	4.90	17.8	5.4	1.37	10.1	11.1				
B12	3	32.0	9.41	12.00	0.335	6.205	0.462	10.102	0.940	B12	0.70	30.2	—	1644	3454	208.2	39.1	4.83	18.5	5.2	1.30	10.2	8.4				
CB12N1	19	32.0	9.42	12.12	0.275	6.535	0.480	10.335	0.892	CB12N1	0.81	37.8	88	2372	5190	247.0	40.8	5.12	22.3	6.4	1.54	10.1	10.8				
B12	9	32.0	9.42	12.12	0.275	6.530	0.480	10.190	0.960	B12	0.80	37.1	47	2472	3674	246.8	40.7	5.11	19.4	5.8	1.44	10.0	8.8				
12W6 B12	10	32.0	9.41	12.12	0.273	6.533	0.480	10.450	0.835	12W6 B12	0.81	36.3	64	2380	4431	246.8	40.7	5.12	22.6	6.3	1.40	10.0	10.0				
12W6	20	32.0	9.41	12.12	0.273	6.533	0.480	10.295	0.913	12W6	0.81	37.7	48	2323	3886	246.8	40.7	5.12	20.8	6.1	1.40	10.0	10.0				
CB121	17	32.0	9.40	12.12	0.274	6.534	0.479	10.335	0.892	CB121	0.80	37.7	48	2309	4210	246.8	40.7	5.12	22.8	6.8	1.54	10.0	10.4				
B12	7	31.5	9.36	12.12	0.270	6.505	0.480	10.190	0.960	B12	0.80	37.7	45	2460	4601	245.7	40.5	5.13	19.4	5.8	1.44	10.0	8.8				
B12	1	31.0	9.13	12.00	0.310	6.160	0.463	10.000	1.000	B12	0.88	35.3	82	2840	5291	235.2	37.5	4.87	14.7	4.8	1.27	10.0	8.0				
12W6 B12	12	31.0	9.12	12.09	0.285	6.505	0.485	10.450	0.820	12W6 B12	1.02	26.4	41	2223	3923	238.4	38.4	5.11	19.8	6.1	1.47	10.0	10.1				
12W6	22	31.0	9.12	12.09	0.285	6.505	0.485	10.295	0.899	12W6	1.02	26.8	43	2294	4729	238.4	38.4	5.11	19.8	6.1	1.47	10.0	10.1				
CB121	22	31.0	9.12	12.09	0.285	6.505	0.485	10.295	0.899	CB121	1.02	27.8	43	2467	3676	238.2	38.3	5.09	17.2	5.8	1.39	10.1	8.8				
B12	6	29.6	8.70	12.00	0.340	6.500	0.496	10.294	0.823	12W6	1.13	22.9	85	2473	4376	238.5	38.3	5.12	17.1	5.3	1.40	10.0	8.8				
12W6	24	29.6	8.70	12.00	0.340	6.500	0.496	10.294	0.823	12W6	1.13	22.9	85	2473	4376	238.5	38.3	5.12	17.1	5.3	1.40	10.0	8.8				
B12	3	28.5	8.42	12.00	0.250	6.120	0.462	10.102	0.849	B12	0.67	40.4	39	2411	4411	218.2	36.0	5.07	18.3	5.8	1.30	10.0	8.1				
B12	1	28.5	8.41	12.00	0.250	6.100	0.463	10.000	1.000	B12	0.68	40.0	40	2462	2880	218.1	36.1	5.07	14.2	4.7	1.30	10.0	7.2				
B12	5	28.5	8.40	12.00	0.250	6.205	0.460	10.140	0.920	B12	0.68	40.8	39	2340	4890	218.0	36.0	5.07	18.2	5.7	1.30	10.0	8.2				
B12	7	28.0	8.28	12.00	0.245	6.500	0.420	10.190	0.920	B12	1.14	41.6	57	2210	4632	213	35.6	5.08	18.4	5.8	1.41	10.0	8.2				

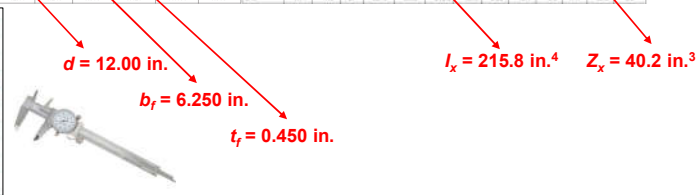
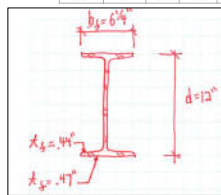

www.aisc.org/publications/historic-shape-references/

Dimensional Data

- Determine rivet shank diameter from finished head diameter
- Kidder-Parker *Architects' and Builders' Handbook*

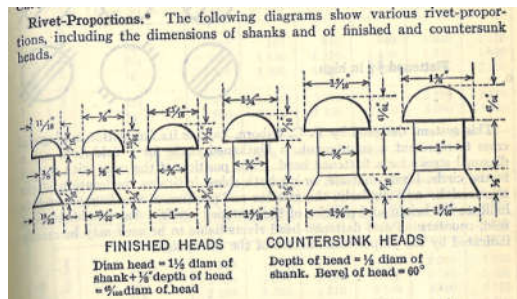
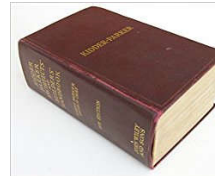

General Design Procedure

Evaluation by Structural Analysis
AISC Specification Appendix 5 Section 5.3

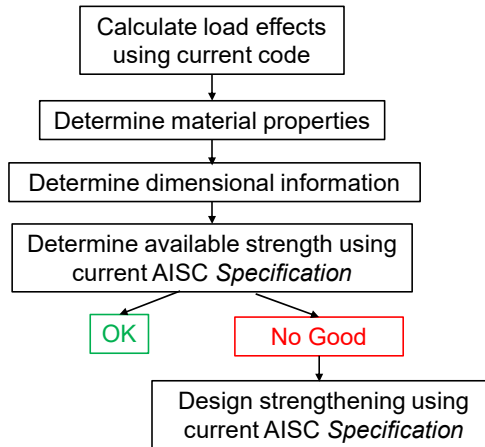

33

Beam Strengthening Example

- Loads on existing beam are increasing due to change in occupancy.
- 1965 construction, A36 steel ($F_y = 36$ ksi).
- Beam size: W12x16.5, compact for flexure, noncomposite with slab.
- Fully braced for lateral-torsional buckling.
- Evaluate and design strengthening using welded plate at bottom flange.

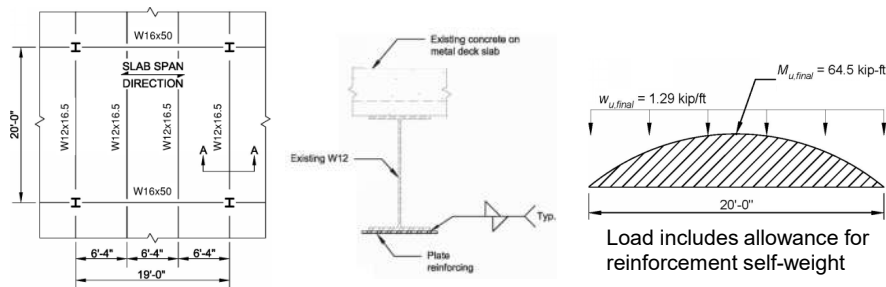

34

Beam Strengthening Example

- Evaluate existing beam to determine if strengthening is required
 - From Appendix 5, evaluate using current AISC *Specification* (not allowable stress provisions from 1965)

$$M_n = M_p = F_y Z_x \quad (\text{Spec. Eq. F2-1})$$

$$\begin{aligned} Z_{x,req} &= \frac{M_u}{\phi_b F_y} \\ &= \frac{(64.5 \text{ kip-ft})(12 \text{ in./ft})}{0.90(36 \text{ ksi})} \\ &= 23.9 \text{ in.}^3 \end{aligned}$$

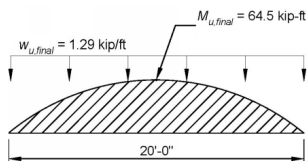

- From DG 15 Table 5-2.1, the geometric properties are:

W12x16.5					
$A = 4.87 \text{ in.}^2$	$d = 12.00 \text{ in.}$	$t_w = 0.230 \text{ in.}$	$b_f = 4.000 \text{ in.}$	$t_f = 0.269 \text{ in.}$	
$k = 13/16 \text{ in.}$	$I_x = 105 \text{ in.}^4$	$S_x = 17.6 \text{ in.}^3$	$Z_x = 20.6 \text{ in.}^3$		



35

Beam Strengthening Example

- Required flexural strength exceeds available strength by 16%
 - Need to increase plastic section modulus from $Z_x = 20.6 \text{ in.}^3$ to $Z_x = 23.9 \text{ in.}^3$
- Before proceeding with strengthening, see if reinforcing can be avoided by fine tuning analysis
 - Accurate dead loads?
 - Live load reduction?
 - Check span dimensions
 - LRFD instead of ASD
 - Consider testing to establish better material properties



36

Beam Strengthening Example

- Common welded reinforcement configurations

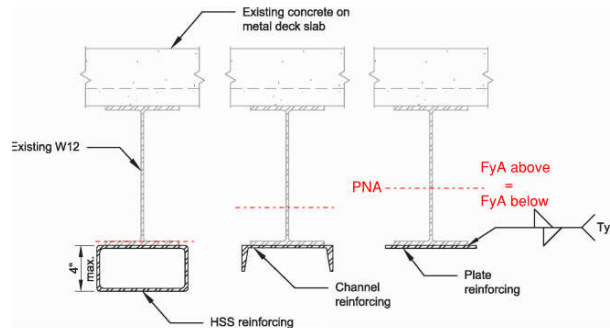

$$M_n = \sum F_y A_i d_i$$

Where d_i = distance from centroid of an element to PNA



37

Beam Strengthening Example

- Common welded reinforcement configurations

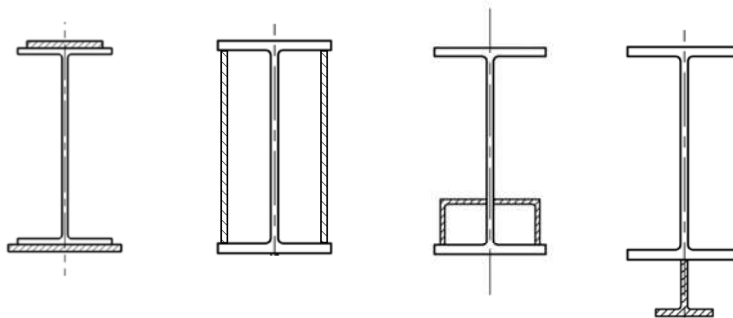

38

Beam Strengthening Example

- The problem with an “allowable stress” approach from an old code
 - Trying to limit elastic stress in existing beam results in an inefficient stress distribution

$$F_b = 0.66F_y$$

$$= 0.66(36 \text{ ksi})$$

$$= 23.8 \text{ ksi}$$

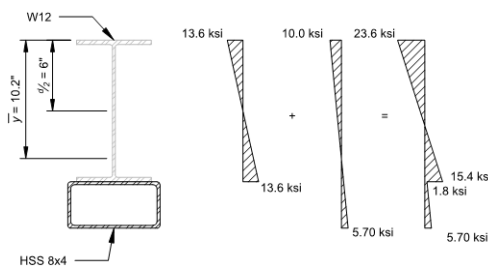

- More efficient designs can be achieved using the strength-based approach of the current AISC *Specification*
 - Ignore loading history (except for serviceability checks)
 - Rely on redistribution of stresses and plastic strength of reinforced section



39

Beam Strengthening Example

- Strength-Based Approach (2016 AISC Specification)
 - Sizing of reinforcing is iterative. Use a spreadsheet.
 - Try a 5-in.-wide by 1/4-in.-thick reinforcing plate and calculate Z_x

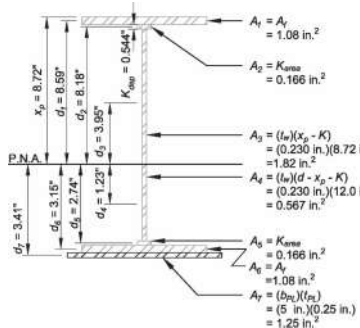

$$A_1 + A_2 + A_3 = A_4 + A_5 + A_6 + A_7$$

$$1.08 \text{ in.}^2 + 0.160 \text{ in.}^2 + 1.82 \text{ in.}^2 = 0.567 \text{ in.}^2 + 0.160 \text{ in.}^2 + 1.08 \text{ in.}^2 + 1.25 \text{ in.}^2$$

$$3.06 \text{ in.}^2 = 3.06 \text{ in.}^2 \text{ o.k.}$$

$$Z_x = \sum A_i d_i$$

$$Z_x = A_1 d_1 + A_2 d_2 + A_3 d_3 + A_4 d_4 + A_5 d_5 + A_6 d_6 + A_7 d_7$$

$$= (1.08 \text{ in.}^2)(8.59 \text{ in.}) + (0.160 \text{ in.}^2)(8.18 \text{ in.}) + (1.82 \text{ in.}^2)(3.95 \text{ in.}) + 0.567 \text{ in.}^2(1.23 \text{ in.})$$

$$+ (0.160 \text{ in.}^2)(2.74 \text{ in.}) + (1.08 \text{ in.}^2)(3.15 \text{ in.}) + (1.25 \text{ in.}^2)(3.41 \text{ in.})$$

$$= 26.6 \text{ in.}^3 > 23.9 \text{ in.}^3 \text{ o.k.}$$



40

Beam Strengthening Example

- Design Welds

- Reinforcing is required over portion of beam where the flexural demand exceeds the available strength:

$$\begin{aligned}
 M_{u,cutoff} &= \phi_b F_y Z \\
 &= \frac{0.90(36 \text{ ksi})(20.6 \text{ in.}^3)}{(12 \text{ in./ft})} \\
 &= 55.6 \text{ kip-ft}
 \end{aligned}$$

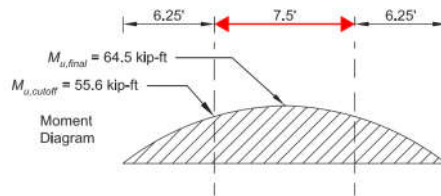

- From AISC *Specification* Section F13.3 (cover plates), the reinforcement must extend beyond the theoretical cutoff point and must be attached with slip-critical bolts or fillet welds.



41

Beam Strengthening Example

- Design Welds

- AISC *Specification* Commentary Section F13.3, end force in cover plate can be conservatively taken as the yield strength of the plate

$$\begin{aligned}
 F_{cutoff} &= F_y A_g \\
 &= (36 \text{ ksi})(5.00 \text{ in})(1/4 \text{ in.}) \\
 &= 45.0 \text{ kips}
 \end{aligned}$$

- Use two 3/16 in. fillet welds, 6 in long

$$\begin{aligned}
 l_{dev} &= \frac{F_{cutoff}}{(2 \text{ welds})(\phi R_n)} \\
 &= \frac{45.0 \text{ kips}}{(2 \text{ welds})(4.18 \text{ kip/in.})} \\
 &= 5.38 \text{ in.} \rightarrow \text{use } 6.00 \text{ in.}
 \end{aligned}$$



42

Beam Strengthening Example

- Cover Plate Terminations
 - AISC *Specification* Section F13.3

3. Cover Plates

For members with cover plates, the following provisions apply:

- (e) For welded cover plates, the welds connecting the cover plate termination to the beam or girder shall be continuous welds along both edges of the cover plate in the length a'

- (1) When there is a continuous weld equal to or larger than three-fourths of the plate thickness across the end of the plate

$$a' = w \quad (F13-5)$$

where

w = width of cover plate, in. (mm)

- (2) When there is a continuous weld smaller than three-fourths of the plate thickness across the end of the plate

$$a' = 1.5w \quad (F13-6)$$

- (3) When there is no weld across the end of the plate

$$a' = 2w \quad (F13-7)$$

- Provide 3/16" weld across end of plate to meet F13.3(e)



43

Beam Strengthening Example

- Design Welds
 - Conservatively design intermittent welds for shear flow at the cutoff point

$$\begin{aligned} v_{u,cutoff} &= \frac{V_{u,cutoff} Q}{I} \\ &= \frac{(4.85 \text{ kips})(6.09 \text{ in.}^3)}{142 \text{ in.}^4} \\ &= 0.208 \text{ kip/in.} \end{aligned}$$

$$Q = A_{PL} \left(d_{W12} - \bar{y} + \frac{t_{PL}}{2} \right)$$

$$I = I_{x,W12} + A_{W12} \left(\frac{d_{W12}}{2} - \bar{y} \right)^2 + I_{y,PL} + A_{PL} \left(d_{W12} + \frac{t_{PL}}{2} - \bar{y} \right)^2$$

- Minimum size and spacing requirements from *Specification* Section J2.2b(e) controls. Use 1 1/2 in. long intermittent welds at 12 in. on center (both sides, staggered)

$$\begin{aligned} \phi R_n &= (2 \text{ welds})(4.18 \text{ kip/in.}) \left(\frac{1.5 \text{ in.}}{12 \text{ in.}} \right) \\ &= 1.05 \text{ kip/in.} > 0.208 \text{ kip/in.} \quad \mathbf{o.k.} \end{aligned}$$



44

Beam Strengthening Example

- Final Design:

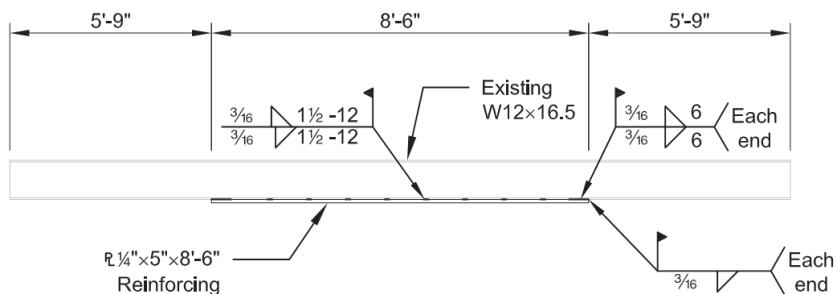

45

Beam Strengthening Example

- Other checks
 - Shear in unreinforced beam
 - Existing connection
 - Check slab, girders, columns, foundation, etc.
 - Deflection

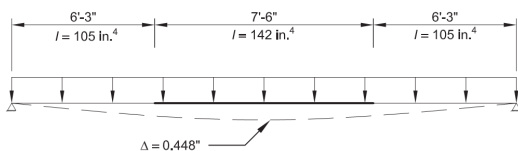
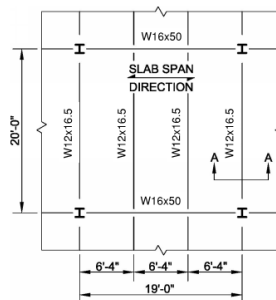

46

Beam Strengthening Example

- Serviceability check for permanent deformations
 - Consider loading history and calculate elastic stresses at top of existing beam under service-level loads

1. Calculate initial stress at time of reinforcement

$$F_b' = M_a' / S_x$$

$$= (20.0 \text{ kip-ft})(12 \text{ in./ft}) / (17.6 \text{ in.}^3)$$

$$= 13.6 \text{ ksi}$$

2. Calculate stress due to superimposed loads on reinforced section

$$F_{b,top} = \frac{(M_{a,final} - M_a')(\bar{y})}{I}$$

$$= \frac{(43.0 \text{ kip-ft} - 20.0 \text{ kip-ft})(12 \text{ in./ft})(7.25 \text{ in.})}{142 \text{ in.}^4}$$

$$= 14.1 \text{ ksi}$$

3. Calculate sum of 1 and 2

$$F_{b,top,final} = F_b' + F_{b,top}$$

$$= 13.6 \text{ ksi} + 14.1 \text{ ksi}$$

$$= 27.7 \text{ ksi}$$

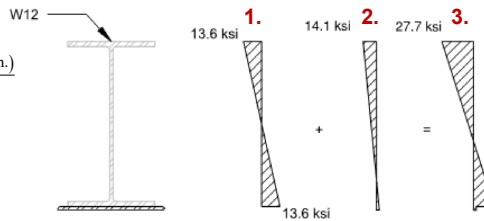

Beam Strengthening Example

- Other checks
 - For cases where elastic stress at top of existing beam is high, consider jacking out some initial stress to avoid yielding of existing beam top fiber

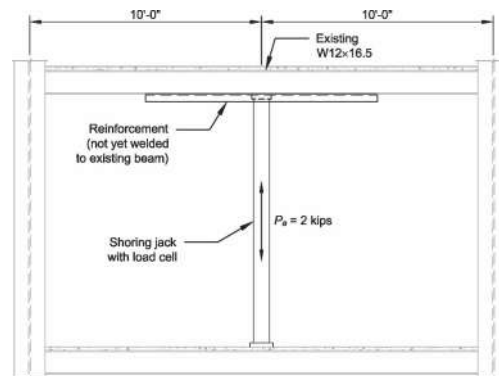

Composite Beam Strengthening

- Same basic approach
 - Locate Plastic Neutral Axis and Calculate M_n

1. Calculate internal forces and find P.N.A.

2. Find flexural strength: sum of internal forces times distance from P.N.A.

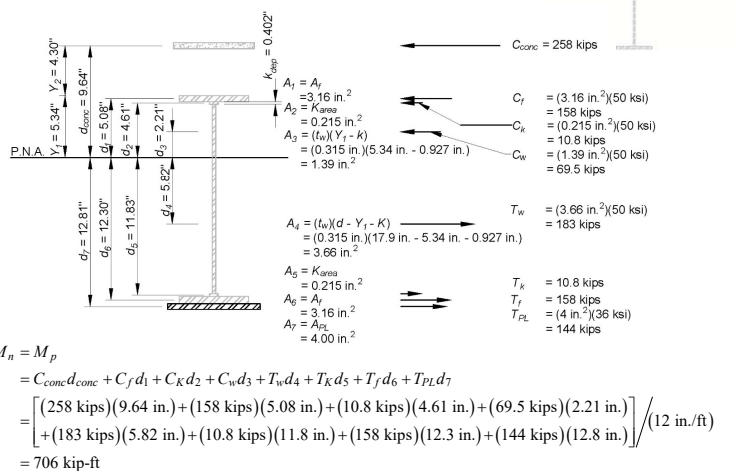

Lateral Torsional Buckling

- Use equations of AISC Specification section F4.2.

2. Lateral-Torsional Buckling

- (a) When $L_b \leq L_p$, the limit state of lateral-torsional buckling does not apply.
- (b) When $L_p < L_b \leq L_r$

$$M_n = C_b \left[R_{pc} M_{yc} - (R_{pc} M_{yc} - F_L S_{xc}) \left(\frac{L_b - L_p}{L_r - L_p} \right) \right] \leq R_{pc} M_{yc} \quad (F4-2)$$

- (c) When $L_b > L_r$

$$M_n = F_{cr} S_{xc} \leq R_{pc} M_{yc} \quad (F4-3)$$

- For members with partial-length reinforcement, refer to Kitipornchai and Trahair, "Elastic Lateral Buckling of Stepped I-Beams," 1971.

- Consider other reinforcing configurations:

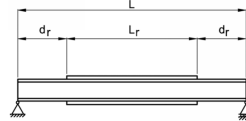
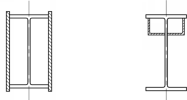

$$\beta_{LTB} = 1 + \frac{2d_r}{L} \left(\frac{M_{e0}}{M_{cr}} - 1 \right)$$



Other Beam Strengthening Schemes

- New beams between existing beams
 - Consider loading sequence
 - Consider effects on existing slab

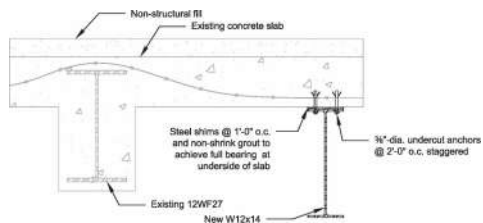
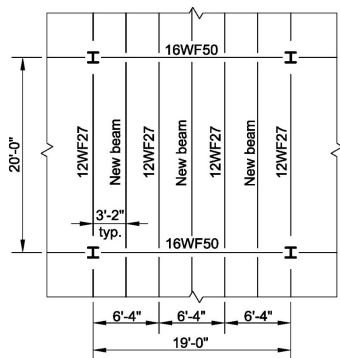

51

Other Beam Strengthening Schemes

- New girder below existing girder (not welded)
 - Can substantially reduce field welding
 - Loading sequence must be considered
 - Loads shared by relative stiffness
 - Headroom restrictions may limit feasibility

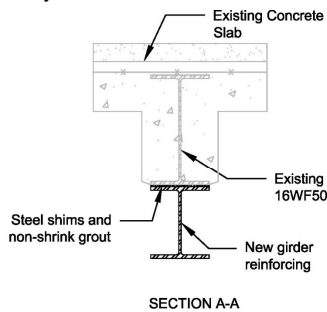
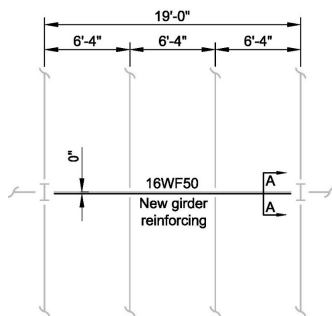

52

Other Beam Strengthening Schemes

- Add underside anchors for composite action

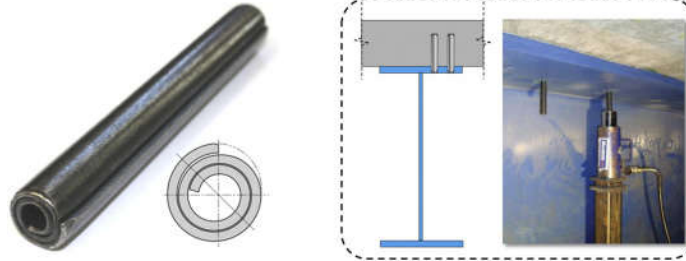

Sources:
Hallmark, Robert et al, "Strengthening Bridges with Postinstalled Coiled Spring Pin Shear Connectors: State-of-the-Art Review," *ASCE Practice Periodical on Structural Design and Construction*, February 2019.
Hallmark, Robert et al, "Post-installed shear connectors: Push-out Tests of Coiled Spring Pins vs. Headed Studs," *Journal of Constructional Steel Research*, October 2019.



55

Other Beam Strengthening Schemes

- Add post-tension cables
 - Can achieve strengthening with no increase to member depth

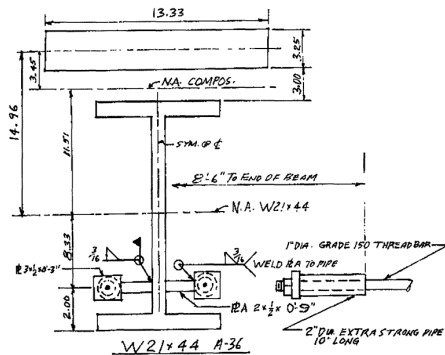

Sources:
Kocis, Peter, "Discussion, Strengthening of Existing Composite Beams Using LRFD Procedures," *Engineering Journal*, Third Quarter, 1997
Iowa DOT, "Strengthening of Steel Girder Bridge Using Post-tensioned FRP Rods/Strands"

56

Other Beam Strengthening Schemes

- Strengthen from top side
 - May be required where beam can not be accessed from below
 - Must use care not to compromise existing slab

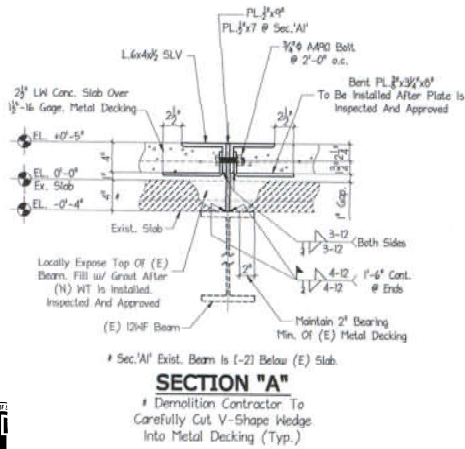

57

Column Strengthening

- Same Design Approach

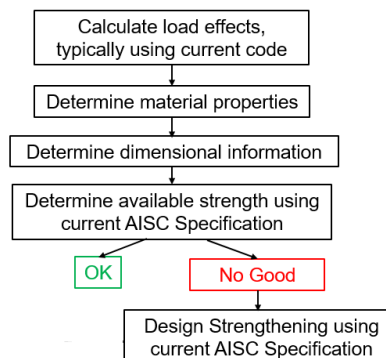

58

Column Strengthening

- Welded Plate Reinforcement
 - Symmetric reinforcement plates most common

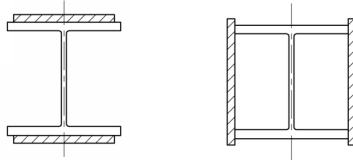

59

Column Strengthening

- Welded Plate Reinforcement
 - Avoid single sided reinforcement where possible
 - Weld distortions can introduce (or increase) secondary moments
 - See "Design of Welded Structures," Blodgett (1966) for quantifying weld distortion

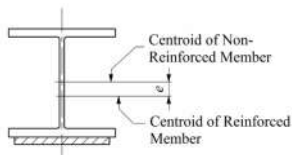

- Even for symmetric reinforcement, specify that welding sequence should limit distortion



Source:
Dowswell, Bo. "Design of Reinforcement for Steel Members," November 2013

60

Column Strengthening

- Welding to existing loaded columns

- Steel begins to lose strength at temperatures exceeding 650°F

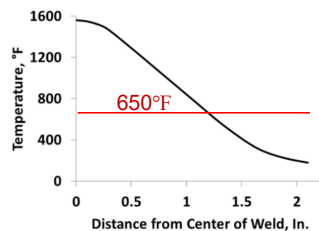

- Yield Strength Curve for Low Heat Input Weld:

$$F'_y = \alpha F_y$$

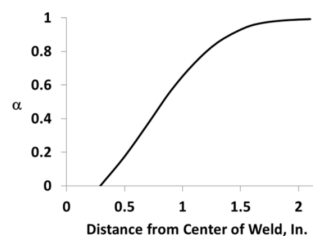

61

Column Strengthening

- Welding to existing loaded columns

- Conservatively consider inactive area (no strength) normal to arc travel

$$w_y = 1 \text{ in. for SMAW}$$

$$w_y = 2 \text{ in. for FCAW}$$

- Design welds to limit heat input

- Avoid oversizing welds
- Avoid overhead welds
- Use intermittent welding with short lengths
- Allow welds to cool between passes
- Avoid transverse welding

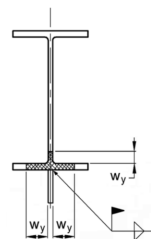

62

Column Strengthening

- Pre-Load Considerations
 - Pre-Load: Load in column at time of strengthening
 - When reinforcing is “stabilizing,” the column pre-load can be neglected.
 - “Stabilizing” if $r_r \geq 0.85r_0$
 - r_0 : Least radius of gyration of unreinforced column
 - r_r : Least radius of gyration of reinforced column
 - Finding is supported by physical tests and finite element models:
 - Tall (1989)
 - Nagaraja Rao and Tall (1963)
 - Wu and Grondin (2002)
 - For other cases, loading history must be considered



63

Column Strengthening Example

- Loads on existing column are increasing due to change in occupancy
- A7 Steel ($F_y = 33$ ksi)
- Column size: 10WF66 (compact for compression)
- Evaluate column for increased loads and design welded plate reinforcement

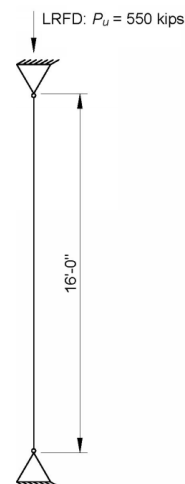

64

Column Strengthening Example

- Available strength cannot be determined from AISC *Manual* Table 4-1. Use *Specification* Section E3.

- From DG 15, Table 5-3.1, the geometric properties are:

$$\begin{array}{llllll}
 \text{10WF66} & & & & & \\
 A = 19.41 \text{ in.}^2 & d = 10.38 \text{ in.} & t_f = 0.748 \text{ in.} & I_x = 382.5 \text{ in.}^4 & r_x = 4.44 \text{ in.} & \\
 I_y = 129.2 \text{ in.}^4 & r_y = 2.58 \text{ in.} & & & &
 \end{array}$$

- Effective length:

$$\begin{aligned}
 L_c &= KL \\
 &= 1.0(16.0 \text{ ft})(12 \text{ in./ft}) \\
 &= 192 \text{ in.}
 \end{aligned}$$

- Elastic Buckling stress:

$$\begin{aligned}
 F_e &= \frac{\pi^2 E}{\left(\frac{L_c}{r}\right)^2} && (\text{Spec. Eq. E3-4}) \\
 &= \frac{\pi^2 (29,000 \text{ ksi})}{\left(\frac{192 \text{ in.}}{2.58 \text{ in.}}\right)^2} = 51.6 \text{ ksi}
 \end{aligned}$$

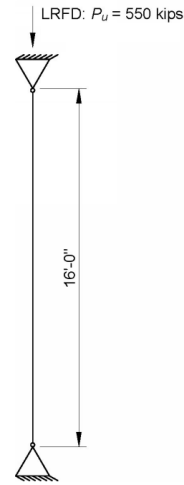

65

Column Strengthening Example

- The critical stress is:

$$\begin{aligned}
 F_{cr} &= \left(0.658^{\frac{F_y}{F_e}}\right) F_y \\
 &= \left[0.658^{0.640}\right] 33 \text{ ksi} \\
 &= 25.2 \text{ ksi}
 \end{aligned}$$

- The nominal compressive strength is:

$$\begin{aligned}
 P_n &= F_{cr} A_g \\
 &= 25.2 \text{ ksi} (19.4 \text{ in.}^2) \\
 &= 489 \text{ kips}
 \end{aligned}$$

- The available strength is:

$$\begin{aligned}
 \phi P_n &= 0.90 (489 \text{ kips}) \\
 &= 440 \text{ kips} < 550 \text{ kips} \quad \mathbf{n.g.}
 \end{aligned}$$

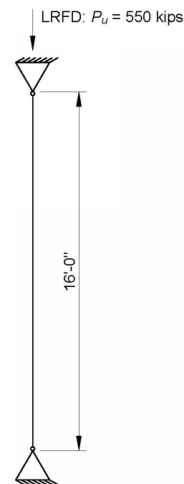

66

Column Strengthening Example

- Use a symmetrical welded plate design
- Estimate required area of reinforced section, A_0 , as:

$$A_0 \approx \frac{P_u}{\phi P_n} A$$

$$\approx \frac{550 \text{ kips}}{440 \text{ kips}} (19.4 \text{ in.}^2)$$

$$\approx 24.3 \text{ in.}^2$$

- Try two PL 3/8" x 8" reinforcing plates

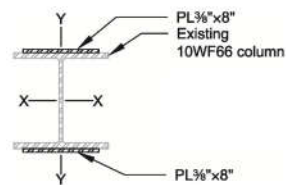

$$A_0 = A + 2A_f$$

$$= 19.4 \text{ in.}^2 + 2(3.00 \text{ in.}^2)$$

$$= 25.4 \text{ in.}^2$$

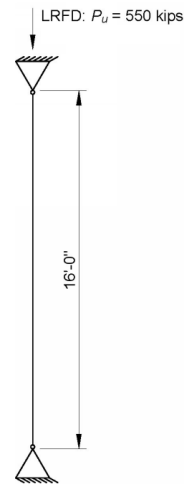

67

Column Strengthening Example

- Check that reinforcing plates are non slender per AISC *Specification* Table B4.1a, case 7, "Flange Cover Plates"

$$\frac{b}{t} = \frac{8.00 \text{ in.}}{3/8 \text{ in.}} = 21.3$$

$$\lambda_r = 1.40 \sqrt{\frac{E}{F_y}} = 1.40 \sqrt{\frac{29,000 \text{ ksi}}{36 \text{ ksi}}} = 39.7 > 21.3 \text{ o.k.}$$

- Section Properties of Reinforced Section:

$$I_o = I_y + 2(I_{xi}) = 129 \text{ in.}^4 + 2(16.0 \text{ in.}^4) = 161 \text{ in.}^4$$

$$I_{xi} = \frac{tb^3}{12} = \frac{0.375 \text{ in.}(8.00 \text{ in.})^3}{12} = 16.0 \text{ in.}^4$$

$$r_o = \sqrt{\frac{I_o}{A_0}} = \sqrt{\frac{161 \text{ in.}^4}{25.4 \text{ in.}^2}} = 2.52 \text{ in.}$$

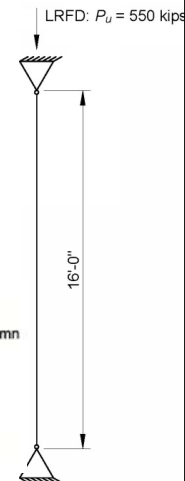
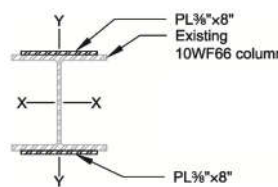

68

Column Strengthening Example

- Conservatively assume $F_y = 33$ ksi for the yield strength of the column and the reinforcing plates
- The elastic buckling stress is:

$$F_e = \frac{\pi^2 E}{\left(\frac{L_c}{r}\right)^2}$$

$$= \frac{\pi^2 (29,000 \text{ ksi})}{\left(\frac{192 \text{ in.}}{2.52 \text{ in.}}\right)^2}$$

$$= 49.3 \text{ ksi}$$

- F_y/F_e is less than 2.25, so the critical stress is:

$$F_{cr} = \left(0.658^{\frac{F_y}{F_e}}\right) F_y$$

$$= \left[(0.658)^{0.669}\right] 33 \text{ ksi}$$

$$= 24.9 \text{ ksi}$$

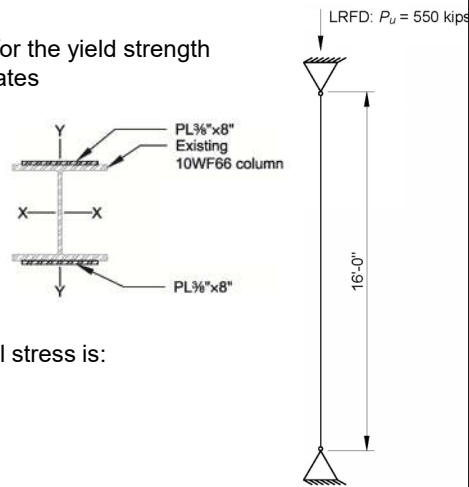

69

Column Strengthening Example

- The nominal compressive strength is:

$$P_n = F_{cr} A_g$$

$$= 24.9 \text{ ksi} (25.4 \text{ in}^2)$$

$$= 632 \text{ kips}$$

- The available strength is:

$$\phi P_n = 0.90 (632 \text{ kips})$$

$$= 569 \text{ kips} > 550 \text{ kips} \quad \text{o.k.}$$

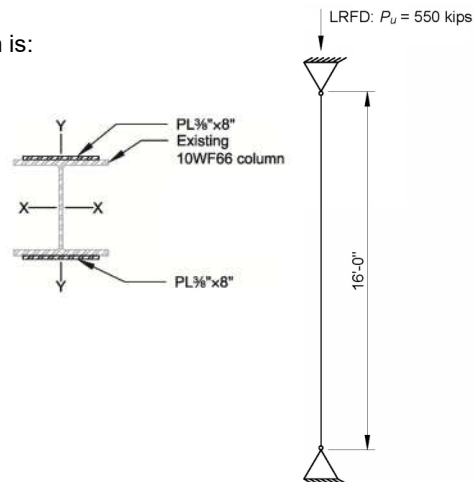

70

Column Strengthening Example

- Design welds and check prescriptive requirements of AISC *Specification* Section E6 for built-up columns.
 - From *Specification* Section E6.1, design the end welds for the yield strength of the reinforcing plates:

$$\begin{aligned}
 P_u &= F_y A_g \\
 &= 36 \text{ ksi} (3.00 \text{ in.}^2) \\
 &= 108 \text{ kips}
 \end{aligned}$$

- Using 1/4 in. fillet welds, the required weld length is:

$$\begin{aligned}
 l_{\text{weld}} &= \frac{P_u}{(2 \text{ welds})(\phi R_n)} \\
 &= \frac{108 \text{ kips}}{(2 \text{ welds})(5.57 \text{ kip/in.})} \\
 &= 9.69 \text{ in.} \rightarrow \text{use 10 in.}
 \end{aligned}$$

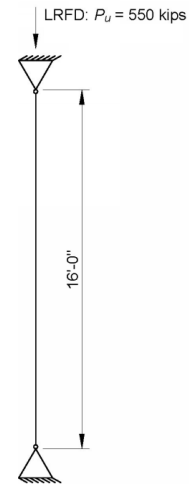

71

Column Strengthening Example

- From AISC *Specification* Section E6.1(b), a modified slenderness ratio is required when $a/r_i > 40$, where a is the distance between welds.

$$\begin{aligned}
 r_i &= \sqrt{\frac{I_{y,PL}}{A_{PL}}} & a_{\text{max}} &= 40r_i \\
 & & &= 40(0.108 \text{ in.}) \\
 & & &= 4.32 \text{ in.}
 \end{aligned}$$

- Use intermittent welds 1 1/2 in. long at 4 in. on center
- Or 2 in. long at 6 in. on center
 - 'a' can be taken as distance from end of one intermittent weld and start of the next one

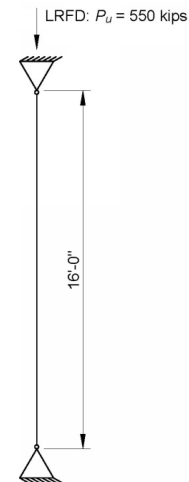

72

Column Strengthening Example

- From AISC *Specification* Section E6.2(a), the reinforcing plates must be connected at intervals, a , such that the slenderness ratio, a/r_i , does not exceed three-fourths times the governing slenderness ratio of the built-up member

$$\frac{a}{r_i} = \frac{4.00 \text{ in.}}{0.108 \text{ in.}} = 37.0 \quad \frac{3}{4} \left(\frac{L_c}{r_o} \right) = 0.75 \left(\frac{192 \text{ in.}}{2.52 \text{ in.}} \right) = 57.1 > 37.0 \text{ o.k.}$$

- From AISC *Specification* Section E6.2(b), the maximum spacing of intermittent welds shall not exceed the plate thickness times $0.75\sqrt{E/F_y}$, nor 12 in.

$$t \left(0.75 \sqrt{\frac{E}{F_y}} \right) = 0.375 \text{ in.} \left(0.75 \sqrt{\frac{29,000 \text{ ksi}}{36 \text{ ksi}}} \right) = 7.98 \text{ in.} > 4.00 \text{ in. o.k.}$$

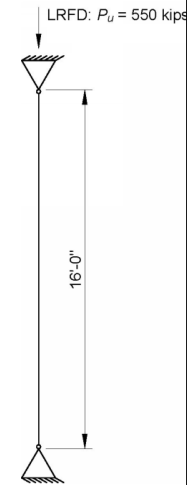

73

Column Strengthening Example

- Final Design:

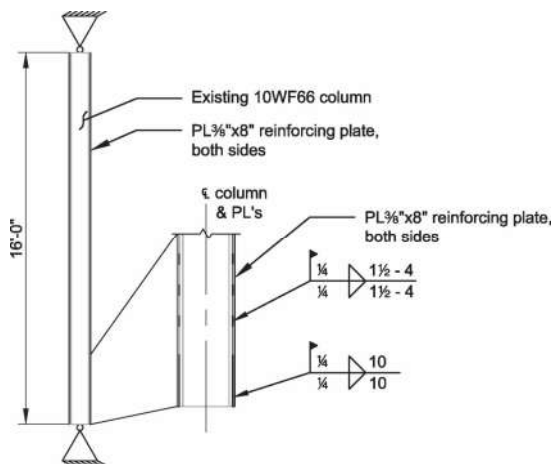

74

Column Strengthening Example

- Plate reinforcement full length can be difficult to achieve
- May need to consider other reinforcing configuration, or partial length reinforcement

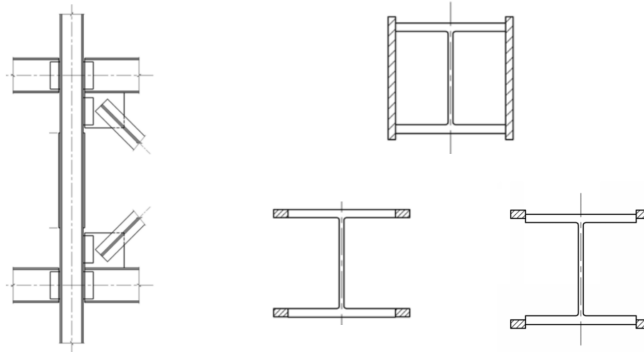

75

Column Strengthening Example

- Consider the same column, but with reinforcement only over half the column length:

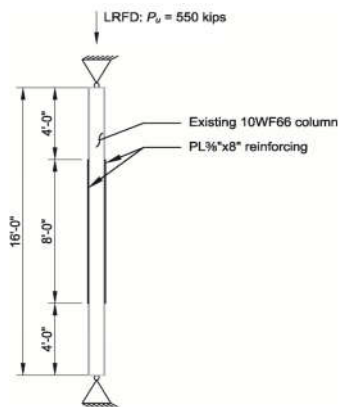

76

Column Strengthening Example

- Critical buckling loads for stepped columns were calculated by Suresh T. Dalal, "Some Non-Conventional Cases of Column Design," *AISC Engineering Journal*, Jan. 1969.

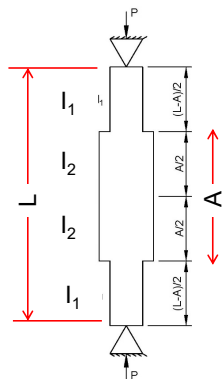

Table 1. Symmetrically Stepped Columns with Hinged Ends

I_2/I_1	A/L	L_{eff}/L	P_{cr}/P_e	I_2/I_1	A/L	L_{eff}/L	P_{cr}/P_e
1.00	0	1.00000	1.00000	2.50	0	1.581139	0.400000
	0.1	1.000000	1.000000		0.1	1.486412	0.452607
	0.2	1.000000	1.000000		0.2	1.392700	0.515567
	0.3	1.000000	1.000000		0.3	1.301612	0.590251
	0.4	1.000000	1.000000		0.4	1.215756	0.676561
	0.5	1.000000	1.000000		0.5	1.139128	0.770647
	0.6	1.000000	1.000000		0.6	1.076937	0.862223
	0.7	1.000000	1.000000		0.7	1.033731	0.935804
	0.8	1.000000	1.000000		0.8	1.010048	0.980202
	0.9	1.000000	1.000000		0.9	1.001243	0.997519
	1.0	1.000000	1.000000		1.0	1.000000	1.000000
1.10	0	1.048809	0.909091	3.00	0	1.732051	0.333333
	0.1	1.039340	0.925731		0.1	1.616702	0.382596
	0.2	1.030270	0.942103		0.2	1.502243	0.443118
	0.3	1.021991	0.957428		0.3	1.390166	0.517448
	0.4	1.014852	0.970945		0.4	1.283080	0.607425
	0.5	1.009110	0.982027		0.5	1.185418	0.711635
	0.6	1.004884	0.990302		0.6	1.103889	0.820633
	0.7	1.002133	0.995748		0.7	1.045766	0.914390
	0.8	1.000647	0.998708		0.8	1.013566	0.973410
	0.9	1.000082	0.999836		0.9	1.001664	0.996681
	1.0	1.000000	1.000000		1.0	1.000000	1.000000



77

Column Strengthening Example

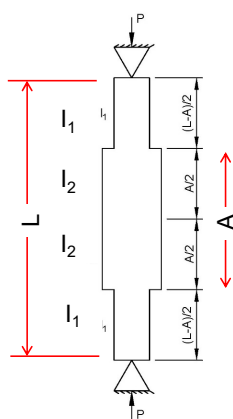

$I_1 = 129 \text{ in.}^4$
 $I_2 = 161 \text{ in.}^4$
 $L = 16.0 \text{ ft}$
 $A = 8.00 \text{ ft}$

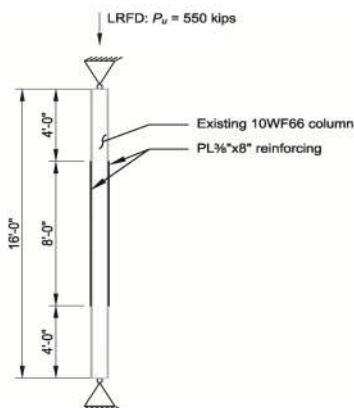

78

Column Strengthening Example

- Suresh T. Dalal, "Some Non-Conventional Cases of Column Design" (1969). Excerpt from Table 1:

$$\alpha = A/L = 8.00 \text{ ft}/16.0 \text{ ft} = 0.500$$

$$\beta = I_2/I_1 = 161 \text{ in.}^4/129 \text{ in.}^4 = 1.25$$

$$L_{\text{eff}}/L = \frac{1.018265 + 1.027461}{2} = 1.02$$

$$L_c = 1.02L = 1.02(16.0 \text{ ft}) = 16.3 \text{ ft}$$

I_2/I_1	A/L	L_{eff}/L
1.20	0.0	1.095445
	0.1	1.077295
	0.2	1.059814
	0.3	1.043709
	0.4	1.029671
	0.5	1.018265
	0.6	1.009810
	0.7	1.004282
	0.8	1.001297
	0.9	1.000164
	1.0	1.000000
1.30	0.0	1.140175
	0.1	1.113998
	0.2	1.088670
	0.3	1.065150
	0.4	1.044447
	0.5	1.027461
	0.6	1.014775
	0.7	1.006449
	0.8	1.001950
	0.9	1.000246
	1.0	1.000000



79

Column Strengthening Example

- The column compression strength is determined using the same procedure shown previously.

- Consider two limit states:

- Strength of reinforced column using $L_c = 16.3 \text{ ft}$ instead of 16 ft

$$\phi P_n = \phi F_{cr} A_g = 0.9(24.6 \text{ ksi})(25.4 \text{ in.}^2) = 563 \text{ kips} > 550 \text{ kips} \quad \text{o.k.}$$

- Strength of unreinforced column section, consider with $L_c = 4 \text{ ft}$

$$\phi P_n = \phi F_{cr} A_g = 0.9(32.5 \text{ ksi})(19.4 \text{ in.}^2) = 568 \text{ kips} > 550 \text{ kips} \quad \text{o.k.}$$

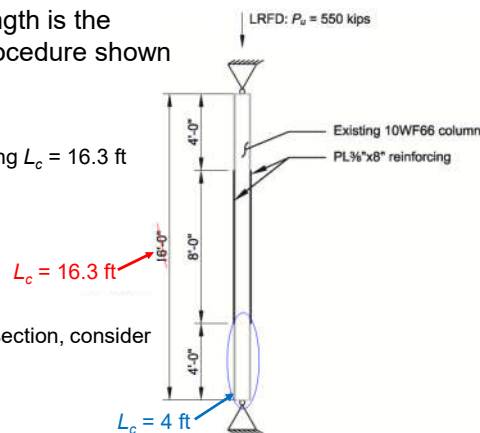

80

Column Strengthening Example

- Final Design:

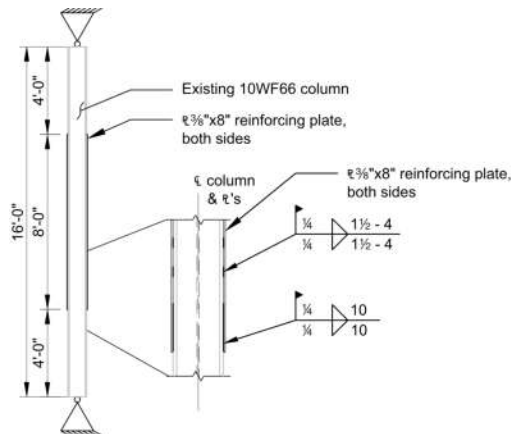

81

Other Column Strengthening Methods

- Concrete Encasement

- Design using AISC *Specification* Section 16.2a for the case where external force is applied directly to the steel section.
- Access required on four sides of column

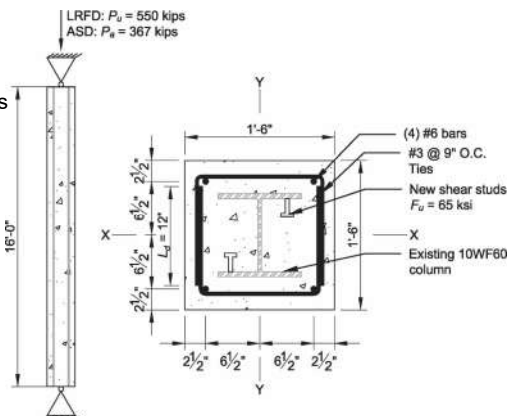

82

Other Column Strengthening Methods

- Provide bracing to reduce effective length

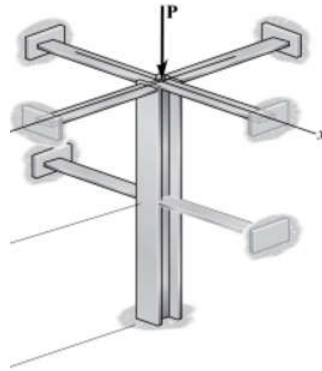

83

Connection Strengthening

- Same Design Approach

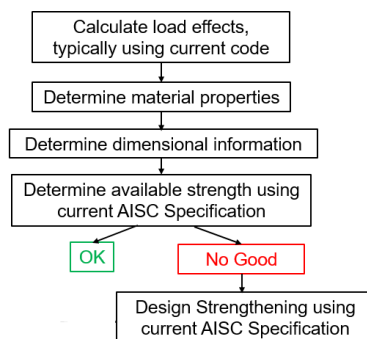

84

Connection Strengthening

- Check all applicable limit states of AISC *Specification* Chapter J.
- Rivets are considered as analogous to bolts without threaded parts.
 - Per AISC *Specification* Appendix 5, assume rivets are ASTM A502, Grade 1
 - Use $F_u = 52$ ksi from historic rivet Specification in DG 15.

6. Bolts and Rivets

Representative samples of bolts shall be inspected to determine markings and classifications. Where bolts cannot be properly identified, representative samples shall be taken and tested to determine tensile strength in accordance with ASTM F606/F606M and the bolt classified accordingly. Alternatively, the assumption that the bolts are ASTM A307 is permitted. Rivets shall be assumed to be ASTM A502 Grade 1 unless a higher grade is established through documentation or testing.



85

Connection Strengthening Example

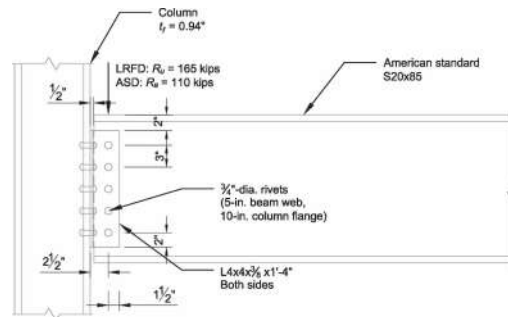

- Check rivet shear. From AISC *Specification* Table J3.2

$$\begin{aligned}
 F_{nv} &= 0.563F_u \\
 &= 0.563(52 \text{ ksi}) \\
 &= 29.3 \text{ ksi}
 \end{aligned}$$



86

Connection Strengthening Example

- The strength of 5 rivets in double shear (or 10 rivets in single shear) is:

$$R_n = F_{nv} A_b$$

$$= (29.3 \text{ ksi})(0.442 \text{ in.}^2)(5 \text{ rivets})(2 \text{ faying surfaces})$$

$$= 130 \text{ kips}$$

- The available strength for rivet shear is:

$$\phi R_n = 0.75(130 \text{ kips})$$

$$= 97.5 \text{ kips} < 165 \text{ kips} \quad \text{n.g.}$$

- Also perform checks for:

- Rivet bearing
- Angle shear yield
- Angle shear rupture
- Block shear

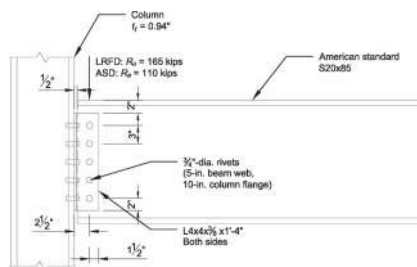

87

Connection Strengthening Example

- Strengthening Option 1: Replace Rivets with Bolts**

- From AISC *Manual* Table 7-1, the available strength for five 3/4-in.-dia. A325 bolts in double shear is:

$$\phi_v r_n = (35.8 \text{ kips})(5 \text{ bolts})$$

$$= 179 \text{ kips} > 165 \text{ kips} \quad \text{o.k.}$$

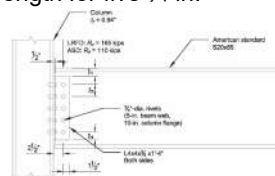

- Chisel or burn off rivet head, then push out. Use care not to gouge angle or beam web.
- Shore beam during replacement, or specify sequence (remove and replace one at a time)
- If needed, consider using A490 bolts, or larger diameter bolts



88

Connection Strengthening Example

- **Strengthening Option 1: Replace Rivets with Bolts**
- Consider replacing only some rivets with slip-critical bolts
 - AISC *Specification* Section J1.10:

10. High-Strength Bolts in Combination with Rivets

In both new work and alterations, in connections designed as slip-critical connections in accordance with the provisions of Section J3, high-strength bolts are permitted to be considered as sharing the load with existing rivets.



89

Connection Strengthening Example

- **Strengthening Option 2: Add Welds**
- AISC *Specification* Section J1.9:

9. Welded Alterations to Structures with Existing Rivets or Bolts

In making welded alterations to structures, existing rivets and high-strength bolts in standard or short-slotted holes transverse to the direction of load and tightened to the requirements of slip-critical connections are permitted to be utilized for resisting loads present at the time of alteration, and the welding need only provide the additional required strength. The weld available strength shall provide the additional required strength, but not less than 25% of the required strength of the connection.

User Note: The provisions of this section are generally recommended for alteration in building designs or for field corrections. Use of the combined strength of bolts and welds on a common faying surface is not recommended for new design.



90

Connection Strengthening Example

- **Strengthening Option 2: Add Welds**

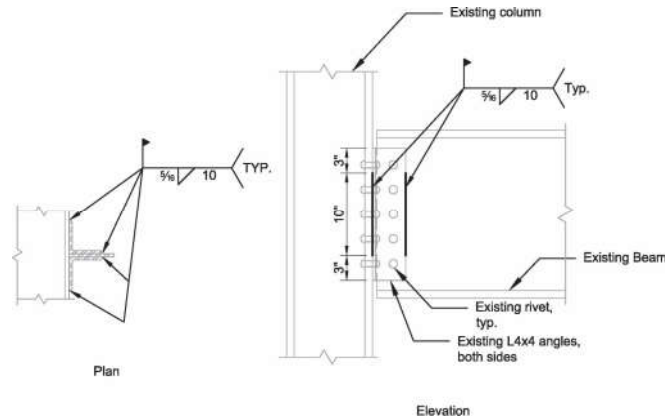

91

Connection Strengthening Example

- **Strengthening Option 3: Add Seated Connection**

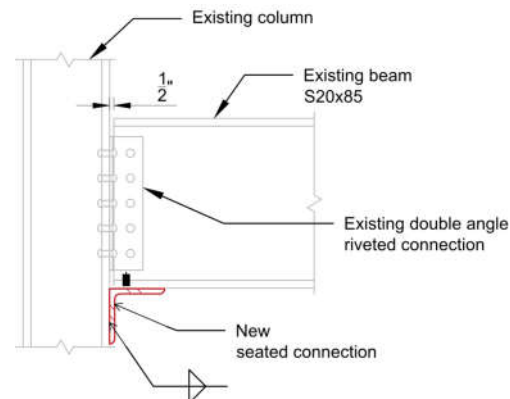

92

Connection Strengthening Example

- **Strengthening Option 3: Add Seated Connection**

Unstiffened seat
does not have stiffness
compatibility

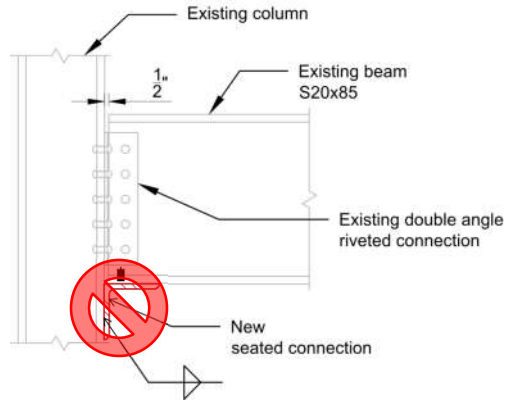

93

Connection Strengthening Example

- **Strengthening Option 3: Add Seated Connection**

Stiffened seat has better
stiffness compatibility.

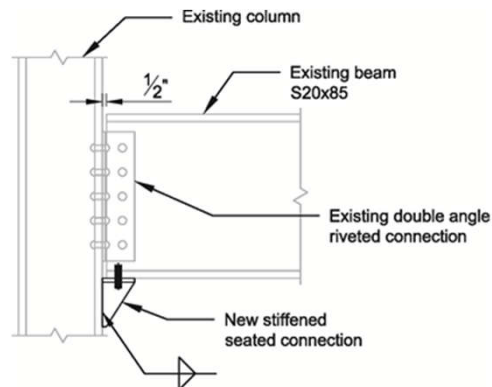

94

Connection Strengthening Example

- **Strengthening Option 3: Add Seated Connection**
- Could design seat for all loads not present at time of seat installation, per *Specification* Section J1.9
- Due to deformation compatibility concerns, we will conservatively consider full load $R_u = 165$ kips
- AISC *Manual* Table 10-8
 - Seat width of $W = 4$ in.
 - Seat depth of $l = 14$ in.
 - Weld size of $5/16$ in.

Table 10-8
Bolted/Welded Stiffened
Seated Connections
Weld Available Strength, kips

L, in.	Width of Seat, W, in.											
	4						5					
	70-kal Weld Size, in.											
	5/16						3/8					
	ASD	LRFD	ASD	LRFD	ASD	LRFD	ASD	LRFD	ASD	LRFD	ASD	LRFD
6	22.7	34.0	28.4	42.5	34.0	51.1	39.7	59.6	23.5	35.2	28.2	42.2
7	29.8	44.8	37.4	56.1	44.9	67.3	52.4	78.6	31.2	46.9	37.5	56.2
8	37.8	56.7	47.2	70.8	56.7	85.0	66.1	95.2	39.8	59.8	47.8	71.7
9	46.1	69.2	57.7	86.5	69.2	104	80.7	121	48.1	72.7	59.9	88.5
10	54.9	82.3	68.8	103	82.3	123	96.0	144	58.0	88.5	70.8	106
11	63.9	95.8	79.8	120	95.8	144	112	165	68.4	104	83.3	125
12	73.1	110	91.4	137	110	165	129	190	80.2	120	96.2	144
13	82.5	124	103	156	124	188	144	217	91.3	137	110	164
14	92.1	138	115	176	138	207	161	243	103	154	123	185
15	102	152	127	191	152	229	178	267	114	171	137	206

$$\phi R_n = 173 \text{ kips} > 165 \text{ kips} \quad \text{o.k.}$$



95

Connection Strengthening Example

- **Strengthening Option 3: Add Seated Connection**
- Follow detailing requirements of *Manual* figure 10-10(b)

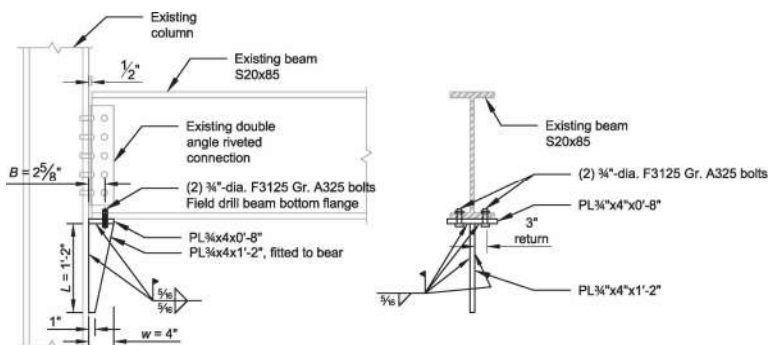

96

References

- AWS, *Structural Welding Code - Steel*, ANSI/AWS D1.1/D1.1M, American Welding Society, Miami, FL, 2015.
- AWS, *Guide for Strengthening and Repairing Existing Structures*, ANSI/AWS D1.7/D1.7M, American Welding Society, Miami, FL, 2009.
- Blodgett, O.W., *Design of Welded Structures*, James F. Lincoln Arc Welding Foundation, Cleveland, OH, 1966.
- Brown, J. H., "Reinforcing Loaded Steel Compression Members," *Engineering Journal*, Vol. 25, No. 4, AISC, 1988.
- Dalal, S.T., "Some Non-Conventional Cases of Column Design," *AISC Engineering Journal*, January 1969.
- Dowswell, B., "Reinforcing the Point," *Modern Steel Construction*, AISC, January 2014.
- Garlich, M.J., "Welding to Existing Structures," *North American Steel Construction Conferences*, Las Vegas, February 2000.
- Gustafson, K., "Evaluation of Existing Structures," *Modern Steel Construction*, AISC, February 2007.
- Kidder and Parker, *Architects' and Builders' Handbook*, 18th Edition, John Wiley and Sons, 1954.
- Koesis, P., Discussion of paper by Miller, J.P., "Strengthening of Existing Composite Beams Using LRFD Procedures," *Engineering Journal*, Vol. 34, No. 3, AISC, 1997.
- Marzouk, H., Mohan, S., "Strengthening of Wide-Flange Columns Under Load," *Canadian Journal of Civil Engineering*, April 1990.



97

References

- Miller, J.P., "Strengthening of Existing Composite Beams Using LRFD Procedures," *Engineering Journal*, Vol. 33, No. 2, AISC, 1996.
- Nagaraja Ras, N.R. and Tall, L., "Columns Reinforced Under Load," *Welding Journal*, Vol. 42, AWS, April 1963
- Ricker, D.T., "Field Welding to Existing Steel Structures," *Engineering Journal*, Vol. 25, No. 1, AISC, 1988.
- Ruddy, J. L., "Reinforcing In-Place Structural Elements," *Proceedings of the National Engineering Conference and Conference of Operating Personnel*, AISC, New Orleans, LA, 1987.
- Tall, L., "The Reinforcement of Steel Columns," *Engineering Journal*, Vol. 26, No. 2, AISC, 1989.
- Tide, R.H.R., "Reinforcing Steel Members and the Effects of Welding," *Engineering Journal*, Vol. 2, No. 4, AISC, 1990.
- Tide, R.H.R., "Basic Considerations When Reinforcing Existing Steel Structures," *Proceedings of the National Engineering Conference and Conference of Operating Personnel*, AISC, New Orleans, LA, 1987.
- Trahair, N.S. and Kitipornchai, S., "Elastic Lateral Buckling of Stepped I-Beam," *Journal of the Structural Division*, 1971.
- Wu, Z., Grondin, G.Y., "Behaviour of Steel Columns Reinforced with Welded Steel Plates," *University of Alberta Department of Civil & Environmental Engineering*, December 2002.



98

AISC | Questions?



**Smarter.
Stronger.
Steel.**

PDH Certificates

- You will receive an email on how to report attendance from: registration@aisc.org.
- Be on the lookout: Check your spam filter! Check your junk folder!
- Completely fill out online form. Don't forget to check the boxes next to each attendee's name!



**Smarter.
Stronger.
Steel.**



PDH Certificates

- Reporting site (URL will be provided in the forthcoming email).
- Username: Same as AISC website username.
- Password: Same as AISC website password.



AISC | Thank you.

