

AISC Live Webinars

Thank you for joining our live webinar today.
We will begin shortly. Please standby.

Designing Built-up Flexural Members
November 5, 2020



AISC Live Webinars

Today's live webinar will begin shortly. Please stand by.

Today's audio will be broadcast through the internet. Please be sure to turn up the volume on your speakers.

Please type any questions or comments through the chat feature in the left portion of your screen.



AISC Live Webinars

AIA Credit

AISC is a Registered Provider with The American Institute of Architects Continuing Education Systems (AIA/CES). Credit(s) earned on completion of this program will be reported to AIA/CES for AIA members. Certificates of Completion for both AIA members and non-AIA members are available upon request.

This program is registered with AIA/CES for continuing professional education. As such, it does not include content that may be deemed or construed to be an approval or endorsement by the AIA of any material of construction or any method or manner of handling, using, distributing, or dealing in any material or product.

Questions related to specific materials, methods, and services will be addressed at the conclusion of this presentation.



AISC Live Webinars

Copyright Materials

This presentation is protected by US and International Copyright laws. Reproduction, distribution, display and use of the presentation without written permission of AISC is prohibited.

© The American Institute of Steel Construction 2020

The information presented herein is based on recognized engineering principles and is for general information only. While it is believed to be accurate, this information should not be applied to any specific application without competent professional examination and verification by a licensed professional engineer. Anyone making use of this information assumes all liability arising from such use.



AISC Live Webinars

Course Description

Designing Built-up Flexural Members
November 5, 2020

Built-up flexural members are made by combining shapes and plates so that they work together as a single flexural member. This webinar will delve into the overall provisions for built-up beams, including all applicable limit states. It will also explore built-up cross-sections such as box and I-shaped beams formed from channels, double angles that form T-shaped sections, and crane rail girders formed with channels as a cap to an I-shape. Examples of a variety of built-up sections will be presented using both ASD and LRFD.



AISC Live Webinars

Learning Objectives

- Identify the sections in the AISC *Specification* that give requirements for the design of built-up flexural members.
- List the dimensional requirements for built-up compression members. Explain how these requirements should be interpreted for flexural members.
- Explain how adding a gap between two back-to-back channels, connected to act as a built-up flexural member, affects flexural strength.
- List the strength limit states for several configurations of built-up flexural members.



Designing Built-up Flexural Members

November 5, 2020

Louis F. Geschwindner, PE, PhD

Professor Emeritus, Architectural Engineering, Penn State University
former Vice President, AISC
Senior Consultant, Providence Engineering Corp.



Smarter.
Stronger.
Steel.



Built-up Flexural Members

- Built-up flexural members are members made by combining shapes and plates so that they work together as a single flexural member.
- If these members are formed from several plates into an I-shape, either doubly or singly symmetric, we will call them plate girders.



8



Built-up Flexural Members

- This presentation will look at the overall provisions for built-up members.
- It will illustrate their application for box and I-shaped beams built-up from channels.
- Double angles that get treated similarly to tees will be considered.
- Crane rail girders composed of a W-shape and a cap channel will be discussed.



9

Built-up Flexural Members

- The only requirements in AISC 360-16 to address built-up beams are found in Section F13.4 as follows:
 - Where two or more beams or channels are used side by side to form a flexural member, they shall be connected together in compliance with Section E6.2.
 - When concentrated loads are carried from one beam to another or distributed between the beams, diaphragms having sufficient stiffness to distribute the load shall be welded or bolted between the beams.



10



Built-up Flexural Members

- The reference to Section E6.2 is to the chapter on compression members, section on built-up members.
- The specific section is titled Dimensional Requirements
 - All of these requirements are intended to force the shapes to work together as a single member.



11

Built-up Flexural Members

- What does it take to make the shapes work together?
 - It depends on the shapes and how they are oriented with respect to each other.
- The limit states to consider remain the same,
 - yielding, local buckling, and lateral-torsional buckling.
- These topics will be addressed through examples.



12

Example 1

- Consider a built-up beam composed of 2C12x25 channels back-to-back in direct contact but not connected. (treat as two single channels)
- Determine the nominal moment strength and plot it for a range of unbraced lengths.

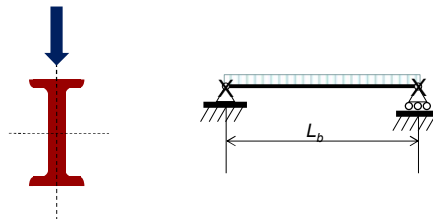

13

Example 1

- Properties for a single C12x25, $F_y = 36$ ksi

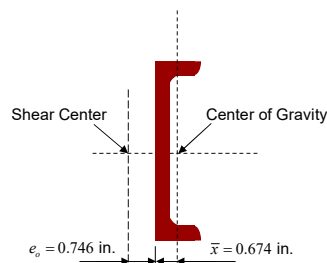

Manual Table 1-5

$A = 7.34 \text{ in.}^2$	$H = 0.909$
$S_x = 24.0 \text{ in.}^3$	$r_y = 0.779 \text{ in.}$
$Z_x = 29.4 \text{ in.}^3$	$r_{ts} = 1.0 \text{ in.}$
$I_y = 4.45 \text{ in.}^4$	$t_f = 0.501 \text{ in.}$
$C_w = 130 \text{ in.}^6$	$t_w = 0.387 \text{ in.}$
$J = 0.538 \text{ in.}^4$	$T = 9.75 \text{ in.}$
$b_f = 3.05 \text{ in.}$	$h_o = 11.5 \text{ in.}$
$\bar{r}_o = 4.72 \text{ in.}$	$I_x = 144 \text{ in.}^4$



14

Example 1

- Check local buckling, Table B4.1b

$$\frac{b_f}{t_f} = \frac{3.05}{0.501} = 6.09 < 0.38 \sqrt{\frac{E}{F_y}} = 0.38 \sqrt{\frac{29,000}{36}} = 10.8$$

$$\frac{h}{t_w} = \frac{(T=9.75)}{0.387} = 25.2 < 3.76 \sqrt{\frac{E}{F_y}} = 3.76 \sqrt{\frac{29,000}{36}} = 107$$

- Thus, the single channel is compact
 - For yielding, by Section F2

$$M_n = M_p = F_y Z_x = 36(29.4) = 1058 \text{ in.-kips} = 88.2 \text{ ft-kips} \quad \text{F2-1}$$



15

Example 1

- Consider lateral-torsional buckling for the single channel according to Section F2.
- Present results for L_b from 0 to 40 ft.
- Determine L_p and L_r

$$L_p = 1.76 r_y \sqrt{\frac{E}{F_y}} = 1.76(0.779) \sqrt{\frac{29,000}{36}} = 38.9 \text{ in.} \Rightarrow 3.24 \text{ ft} \quad \text{F2-5}$$

$$c = \frac{h_o}{2} \sqrt{\frac{I_y}{C_w}} = \frac{11.5}{2} \sqrt{\frac{4.45}{130}} = 1.06 \quad \text{F2-8b}$$



16

Example 1

$$L_r = 1.95r_{ts} \frac{E}{0.7F_y} \sqrt{\frac{Jc}{S_x h_o} + \sqrt{\left(\frac{Jc}{S_x h_o}\right)^2 + 6.76 \left(\frac{0.7F_y}{E}\right)^2}} \quad \text{F2-6}$$

$$= 1.95(1.00) \left(\frac{29,000}{0.7(36)}\right) \sqrt{\frac{0.538(1.06)}{24.0(11.5)} + \sqrt{\left(\frac{0.538(1.06)}{24.0(11.5)}\right)^2 + 6.76 \left(\frac{0.7(36)}{29,000}\right)^2}}$$

$$= 161 \text{ in.} \Rightarrow 13.4 \text{ ft}$$

$$M_r = 0.7F_y S_x = 0.7(36)(24.0) = 604.8 \text{ in.-kips} \Rightarrow 50.4 \text{ ft-kips}$$

$$M_n = C_b \left[M_p - (M_p - 0.7F_y S_x) \left(\frac{L_b - L_p}{L_r - L_p} \right) \right] \leq M_p \quad \text{F2-2}$$



17

Example 1

- Between L_p and L_r

$$M_n = C_b \left[M_p - (M_p - 0.7F_y S_x) \left(\frac{L_b - L_p}{L_r - L_p} \right) \right] \leq M_p \quad \text{F2-2}$$

$$= 1.0 \left[88.2 - (88.2 - 50.4) \left(\frac{L_b - 3.24}{13.4 - 3.24} \right) \right] \leq 88.2 \text{ ft-kips}$$



18

Example 1

- For $L_b > L_r$, determine M_n
As an example, consider $L_b = 15 \text{ ft} > L_r = 13.4 \text{ ft}$

$$M_n = F_{cr} S_x = \frac{C_b \pi^2 E S_x}{\left(\frac{L_b}{r_{ts}}\right)^2} \sqrt{1 + 0.078 \frac{J_c}{S_x h_o} \left(\frac{L_b}{r_{ts}}\right)^2} \quad \text{F2-3, F2-4}$$

$$= \frac{1.0 \pi^2 (29,000)(24.0)}{\left(\frac{15(12)}{1.00}\right)^2} \sqrt{1 + 0.078 \frac{0.538(1.06)}{24.0(11.5)} \left(\frac{15(12)}{1.00}\right)^2}$$

$$= 529 \text{ in.-kips} \Rightarrow 44.1 \text{ ft-kips}$$



19

Example 1

- Nominal strength of a single and a double C12x25 treated as two single members.

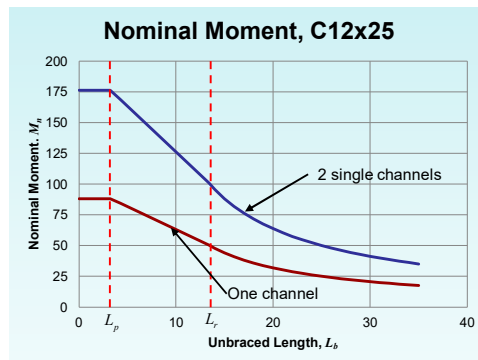

20

Example 1

- Connect these two individual channels so they work together to make a built-up member. What could possibly change?
 - Local buckling – already compact so this won't change.
 - Lateral-torsional buckling – this will improve since the weak axis stiffness will increase if they are properly connected.



21

Example 1

- Look at lateral-torsional buckling as a built-up member.

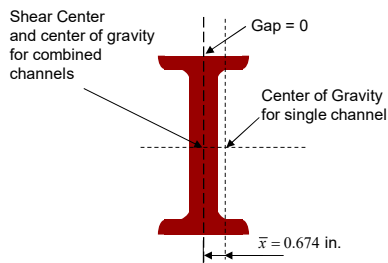

$$I_y = 2[(4.45) + 7.34(0.674)^2] = 15.6 \text{ in.}^4$$

$$r_y = \sqrt{\frac{15.6}{2(7.34)}} = 1.03 \text{ in.}$$

$$L_p = 1.76r_y \sqrt{\frac{E}{F_y}} \quad \text{F2-5}$$

$$= 1.76(1.03) \sqrt{\frac{29,000}{36}} = 51.5 \text{ in.} \Rightarrow 4.29 \text{ ft}$$

Manual Table 1-16 has properties for gap = 0, 3/8, and 3/4 in.



22

Example 1

- For determining L_r , we will assume that the shape we now have is an I-shape.

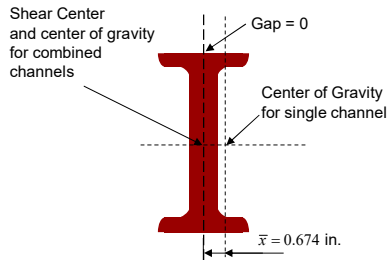

From Section F2

$$c = 1.0$$

$$C_w = \frac{I_y h_o^2}{4} = \frac{15.6(11.5)^2}{4} = 516 \text{ in.}^6$$

$$r_{ts}^2 = \frac{\sqrt{I_y C_w}}{S_x} = \frac{\sqrt{15.6(516)}}{2(24.0)} = 1.87 \text{ in.}^2 \quad \text{F2-7}$$

$$r_{ts} = 1.37 \text{ in.}$$

$$J = 2(0.538) = 1.08 \text{ in.}^4$$



23

Example 1

- For lateral-torsional buckling of the built-up member determine L_r

$$L_r = 1.95 r_{ts} \frac{E}{0.7 F_y} \sqrt{\frac{Jc}{S_x h_o} + \sqrt{\left(\frac{Jc}{S_x h_o}\right)^2 + 6.76 \left(\frac{0.7 F_y}{E}\right)^2}} \quad \text{F2-6}$$

$$= 1.95(1.37) \left(\frac{29,000}{0.7(36)}\right) \sqrt{\frac{1.08(1.0)}{2(24.0)(11.5)} + \sqrt{\left(\frac{1.08(1.0)}{2(24.0)(11.5)}\right)^2 + 6.76 \left(\frac{0.7(36)}{29,000}\right)^2}}$$

$$= 216 \text{ in.} \Rightarrow 18.0 \text{ ft}$$

$$M_p = F_y Z_x = 36(2(29.4)) = 2117 \text{ in.-kips} \Rightarrow 176 \text{ ft-kips}$$

$$M_r = 0.7 F_y S_x = 0.7(36)(2(24.0)) = 1210 \text{ in.-kips} \Rightarrow 101 \text{ ft-kips}$$



24

Example 1

- Continue our example but now for $L_b = 35$ ft.

$$M_n = F_{cr} S_x = \frac{C_b \pi^2 E S_x}{\left(\frac{L_b}{r_{ts}}\right)^2} \sqrt{1 + 0.078 \frac{J_c}{S_x h_o} \left(\frac{L_b}{r_{ts}}\right)^2} \quad \text{F2-3, F2-4}$$

$$= \frac{1.0 \pi^2 (29,000) (2(24.0))}{\left(\frac{35(12)}{1.37}\right)^2} \sqrt{1 + 0.078 \frac{1.08(1.0)}{2(24.0)(11.5)} \left(\frac{35(12)}{1.37}\right)^2}$$

$$= 573 \text{ in.-kips} \Rightarrow 47.7 \text{ ft-kips}$$



2 single channels with $L_b = 35$ ft
would have $M_n = 35.2$ ft-kips

25

Example 1

- Nominal strength of a built-up 2C12x25

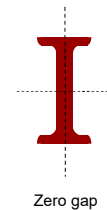
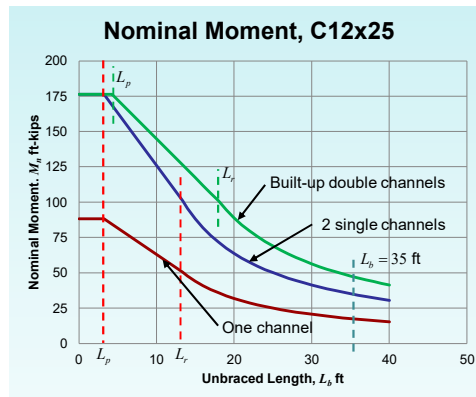

26

Example 2

- Consider a built-up beam composed of these same 2C12x25 channels back-to-back but now with a gap.
- Determine the nominal moment strength and plot along with what we have already determined.

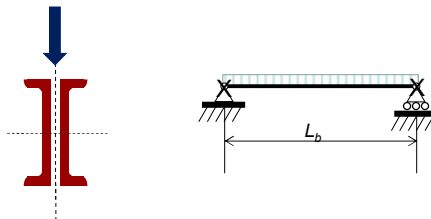

27

Example 2

- As before, lateral-torsional buckling is all that will change.

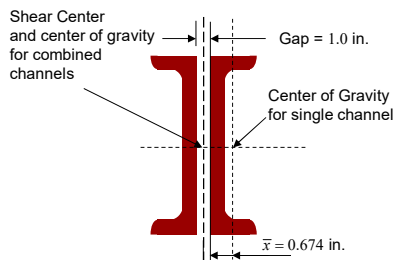

$$I_y = 2 \left[(4.45) + 7.34 \left(0.674 + \frac{1.0}{2} \right)^2 \right] = 29.1 \text{ in.}^4$$

$$r_y = \sqrt{\frac{29.1}{2(7.34)}} = 1.41 \text{ in.}$$

$$L_p = 1.76 r_y \sqrt{\frac{E}{F_y}} \quad \text{F2-5}$$

$$= 1.76(1.41) \sqrt{\frac{29,000}{36}} = 70.4 \text{ in.} \Rightarrow 5.87 \text{ ft}$$



28

Example 2

- For determining L_r , we again treat the shape as an I-shape.

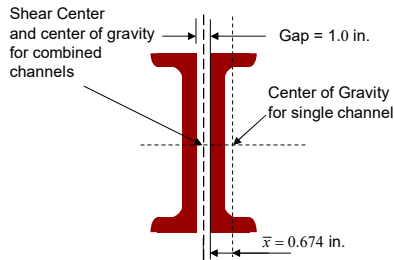

From Section F2

$$c = 1.0$$

$$C_w = \frac{I_y h_o^2}{4} = \frac{29.1(11.5)^2}{4} = 962 \text{ in.}^6$$

$$r_{ts}^2 = \frac{\sqrt{I_y C_w}}{S_x} = \frac{\sqrt{29.1(962)}}{2(24.0)} = 3.49 \text{ in.}^2 \quad \text{F2-7}$$

$$r_{ts} = 1.87 \text{ in.}$$

$$J = 2(0.538) = 1.08 \text{ in.}^4$$



29

Example 2

- For lateral-torsional buckling of the built-up member determine L_r

$$L_r = 1.95 r_{ts} \frac{E}{0.7 F_y} \sqrt{\frac{Jc}{S_x h_o} + \sqrt{\left(\frac{Jc}{S_x h_o}\right)^2 + 6.76 \left(\frac{0.7 F_y}{E}\right)^2}} \quad \text{F2-6}$$

$$= 1.95 (1.87) \left(\frac{29,000}{0.7(36)}\right) \sqrt{\frac{1.08(1.0)}{2(24.0)(11.5)} + \sqrt{\left(\frac{1.08(1.0)}{2(24.0)(11.5)}\right)^2 + 6.76 \left(\frac{0.7(36)}{29,000}\right)^2}}$$

$$= 295 \text{ in.} \Rightarrow 24.6 \text{ ft}$$

$$M_p = F_y Z_x = 36(2(29.4)) = 2117 \text{ in.-kips} \Rightarrow 176 \text{ ft-kips}$$

$$M_r = 0.7 F_y S_x = 0.7(36)(2(24.0)) = 1210 \text{ in.-kips} \Rightarrow 101 \text{ ft-kips}$$



The gap has no influence on M_p or M_r .

30

Example 2

- Again, for $L_b = 35$ ft

$$M_n = F_{cr} S_x = \frac{C_b \pi^2 E S_x}{\left(\frac{L_b}{r_{ts}}\right)^2} \sqrt{1 + 0.078 \frac{Jc}{S_x h_o} \left(\frac{L_b}{r_{ts}}\right)^2} \quad \text{F2-3, F2-4}$$

$$= \frac{1.0 \pi^2 (29,000) (2(24.0))}{\left(\frac{35(12)}{1.87}\right)^2} \sqrt{1 + 0.078 \frac{1.08(1.0)}{2(24.0)(11.5)} \left(\frac{35(12)}{1.87}\right)^2}$$

$$= 803 \text{ in.-kips} \Rightarrow 66.9 \text{ ft-kips}$$



31

Example 2

- Nominal strength of 2C12x25 with 1 in. gap

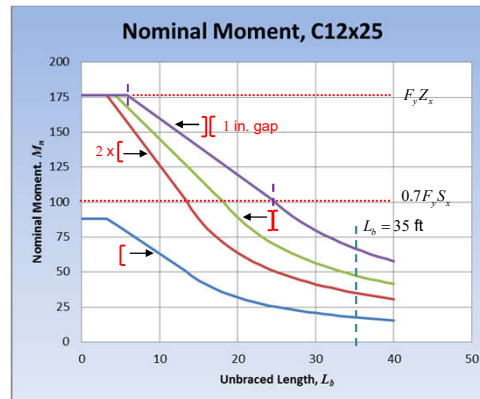
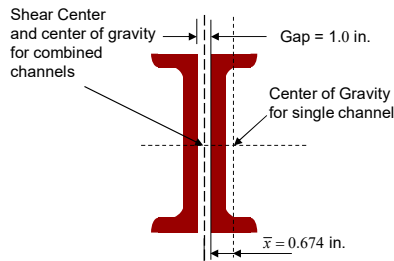

32

E6. Dimensional Requirements

- Remember that these are written for compression members so we must interpret them for our application.
 - First, slenderness of the channel between connectors must be less than $\frac{3}{4}$ of the slenderness of the built-up member over the unbraced length.

$$\frac{a}{r_i} \leq 0.75 \frac{L_b}{r_y}$$



33

E6. Dimensional Requirements

- Remember that these are written for compression members so we must interpret them for our application.
 - Second, the ends of the member must be connected for a length defined either for welds or bolts.
 - Welds; the length shall be at least equal to the maximum width of the member.
 - Bolts; spaced longitudinally not more than 4 diameters apart over a length equal to 1.5 times the maximum width of member.



34

E6 Dimensional Requirements

- Remember that these are written for compression members so we must interpret them for our application.
 - Third, connectors must have sufficient strength to transfer whatever load is required to be transferred.



35

Example 2

- For our built-up beam, back-to-back with no gap

$$\frac{a}{r_i} = \frac{a}{0.779} \leq 0.75 \frac{L_b}{r_y} = 0.75 \left(\frac{L_b}{1.03} \right)$$
$$a \leq 0.567L_b$$

- For the same beam with a 1.0 in. gap

$$\frac{a}{r_i} = \frac{a}{0.779} \leq 0.75 \frac{L_b}{r_y} = 0.75 \left(\frac{L_b}{1.41} \right)$$
$$a \leq 0.414L_b$$



36

Example 2

- At the member ends, the requirement is prescriptive.
- If we are using welds, use a 12 in. weld to connect the channels at the top and bottom.
- With no gap, use 1 intermediate connection, with 1 in. gap use 2 intermediate connections.



37

Example 3

- Consider a built-up beam composed of 2C12x25 channels toe-to-toe in direct contact.
- Determine the nominal moment strength and plot it for a range of unbraced lengths.

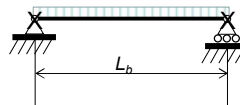

38

Example 3

- Upon first glance it would appear that AISC 360-16 Section F7 would apply
- It addresses square and rectangular HSS and **box sections**
- The intention of the committee was for box-shaped members to be more like HSS with uniform thickness, not our channels

See Glossary definition of Box Section.



39

Example 3

- We already know that all channels in the *AISC Manual* are compact.
- Prior to the 2016 *Specification*, Section F7 did not require consideration of lateral-torsional buckling, if we were following that, we would be finished and

$$M_n = M_p = F_y Z_x = 36(2(29.4)) = 176 \text{ ft-kips} \quad \text{F7-1}$$



40

Example 3

- We could use Section F7.4, but since it does not actually apply, we will not.
- We will, instead, look at this arrangement of channels in much the same way that we looked at the back-to-back channels, through Section F2.
- Again, we have only lateral-torsional buckling to concern ourselves with.



41

Example 3

- Look at lateral-torsional buckling as a built-up member

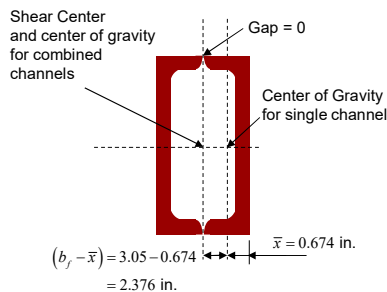

$$I_y = 2[(4.45) + 7.34(2.376)^2] = 91.8 \text{ in.}^4$$

$$r_y = \sqrt{\frac{91.8}{2(7.34)}} = 2.50 \text{ in.}$$

It is not clear that we can use Eq. F2-5 for L_p but we will calculate it and then look at its implications.

$$L_p = 1.76r_y \sqrt{\frac{E}{F_y}} \quad \text{F2-5}$$

$$= 1.76(2.50) \sqrt{\frac{29,000}{36}} = 125 \text{ in.} \Rightarrow 10.4 \text{ ft}$$



42

Example 3

- For determining L_r , there are some terms in Eq. F2-6 that are not defined for our built-up member.
- So we will look at the user note in F2 where it gives the basic equation for doubly symmetric sections.

$$M_{cr} = C_b \frac{\pi}{L_b} \sqrt{EI_y GJ + \left(\frac{\pi E}{L_b}\right)^2 I_y C_w}$$



43

Example 3

- The two terms within the square root represent pure torsion and warping torsion

$$M_{cr} = C_b \frac{\pi}{L_b} \sqrt{EI_y GJ + \left(\frac{\pi E}{L_b}\right)^2 I_y C_w}$$

(Red circles and arrows highlight $EI_y GJ$ and $\left(\frac{\pi E}{L_b}\right)^2 I_y C_w$ respectively)

- For closed sections like the one we are considering warping can be ignored. Thus,

$$M_{cr} = C_b \frac{\pi}{L_b} \sqrt{EI_y GJ}$$



44

Example 3

- From the previous equation we see that we must determine I_y and J .

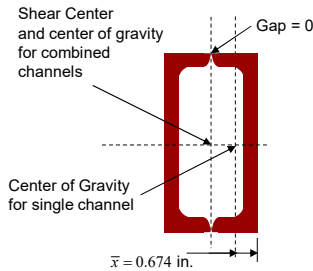

From earlier we know

$$I_y = 2[(4.45) + 7.34(2.376)^2] = 91.8 \text{ in.}^4$$

Using DG 9 Table 3.1 we find

$$J = \frac{2t_f t_w b^2 h^2}{bt_w + ht_f}$$

Which yields

$$J = \frac{2(0.501)(0.387)(6.1 - 0.387)^2 (12.0 - 0.501)^2}{(6.1 - 0.387)(0.387) + (12.0 - 0.501)(0.501)} = 210 \text{ in.}^4$$



45

Example 3

- Using the equation for the elastic lateral-torsional buckling moment with $C_b = 1.0$ and setting it equal to $0.7F_y S_x$ as is done for all other shapes, we can solve for L_r .

$$0.7F_y S_x = C_b \frac{\pi}{L_b} \sqrt{EI_y GJ}$$

yields

$$L_b = L_r = \frac{\pi}{0.7F_y S_x} \sqrt{EI_y GJ}$$



46

Example 3

- Thus

$$L_r = \frac{\pi}{0.7F_y S_x} \sqrt{EI_y GJ}$$

$$= \frac{\pi}{0.7(36)(2(24))} \sqrt{(29,000)(91.8)(11,200)(210)} = 6499 \text{ in.}$$

$$= 542 \text{ ft}$$

- As for our earlier problems

$$M_p = F_y Z_x = 36(2(29.4)) = 2117 \text{ in.-kips} \Rightarrow 176 \text{ ft-kips}$$

$$M_r = 0.7F_y S_x = 0.7(36)(2(24.0)) = 1210 \text{ in.-kips} \Rightarrow 101 \text{ ft-kips}$$



47

Example 3

- Since it is very unlikely that our beam will ever need to span 541 ft, we will just look at a plot of nominal strength to 40 ft.

Using Manual Eq 3-4 in terms of nominal strength

$$M_n = [M_p - BF(L_b - L_p)]$$

BF is the slope.

For our case,

$$BF = \frac{(M_p - M_r)}{(L_r - L_p)}$$

$$= \frac{(176 - 101)}{(541 - 10.4)} = 0.142 \text{ ft-kips/ft}$$

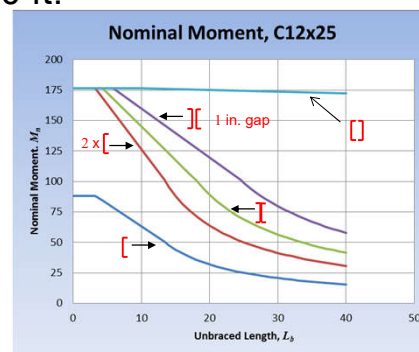

48

Example 3

- Since there was some question as to the appropriateness of our L_p equation, we might consider just using $L_p = 0$ for our calculations.
- With that, the slope becomes

$$BF = \frac{(M_p - M_r)}{(L_r - L_p)}$$

$$= \frac{(176 - 101)}{(541 - 0)} = 0.139 \text{ ft-kips/ft}$$

So the overall questions are,
Does L_p really matter?
and
Does lateral-torsional buckling really matter?



49

Example 3

- Had we used Section F7.4, L_p and L_r would have been a bit different.

$$L_p = 0.13Er_y \frac{\sqrt{JA_g}}{M_p} = 20.6 \text{ ft vs. } 10.4 \text{ ft}$$

$$L_r = 2.0Er_y \frac{\sqrt{JA_g}}{0.7F_y S_x} = 555 \text{ ft vs. } 542 \text{ ft}$$

- But, does it really matter?



50

Example 3

- Using the provisions from E6 considered earlier, determine the required connection between channels

$$\frac{a}{r_i} = \frac{a}{0.779} \leq 0.75 \frac{L_b}{r_y} = 0.75 \left(\frac{L_b}{2.50} \right)$$

$$a \leq 0.234L_b$$

- Use 12 in. end welds and 4 intermediate welds



51

Example 3

- As a final topic with this “box” section, consider the implications for deflection.
- If the span is 40 ft and the allowable moment is $M_n/\Omega = 171/1.67 = 102$ ft-kips
- For a uniform load of $w = \frac{8M_a}{L^2} = \frac{8(102)}{(40)^2} = 0.51$ kip/ft

$$\Delta = \frac{5wL^4}{384EI_x} = \frac{5(0.51)(40)^4(1728)}{384(29,000)(2(144))} = 3.52 \text{ in.} = \frac{L}{136}$$



Likely more deflection than we would accept.

52

Double Angles

- Double angle beams are not addressed as built-up members but rather through Section F9 where they share provisions with Tees.
- The limit states of yielding, lateral-torsional buckling, flange local buckling, and web local buckling must be addressed



53

Double Angles

- As is the case for single angles, the results will depend on orientation of the stem, in tension or compression.

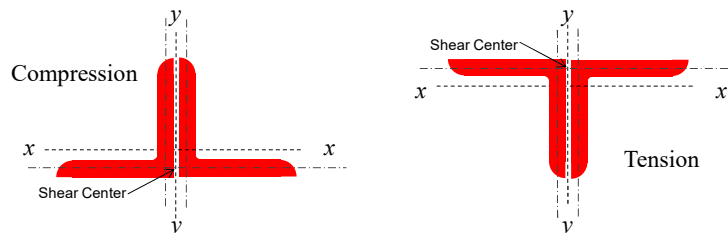

Thinking of these as simple beams, tension on the bottom.



54

Double Angles

- For the local buckling limit states, the double angle provisions in F9 refer to F10 for single angles.
- Yielding and lateral-torsional buckling use the provisions given in F9.
- F9.1 Yielding: Web legs in tension 

$$M_n = M_p = F_y Z_x \leq 1.6 M_y \quad \text{F9-1, F9-2}$$

Web legs in compression 

$$M_n = M_p = 1.5 M_y \quad \text{F9-1, F9-5}$$



55

Double Angles

- F9.2 Lateral-Torsional Buckling
- (a) Web legs in tension 

$$(2) L_p < L_b \leq L_r$$

$$M_n = M_p - (M_p - M_y) \left[\frac{L_b - L_p}{L_r - L_p} \right] \quad \text{F9-6}$$

$$(3) L_b > L_r$$

$$M_n = M_{cr} = \frac{1.95E}{L_b} \sqrt{I_y J} \left[B + \sqrt{1 + B^2} \right] \quad \text{F9-7,10}$$

$$B = +2.3 \left(\frac{d}{L_b} \right) \sqrt{\frac{I_y}{J}} \quad \text{F9-11}$$



56

Double Angles

- F9.2 Lateral-Torsional Buckling

(a) Web legs in tension 

$$L_p = 1.76r_y \sqrt{\frac{E}{F_y}} \quad \text{F9-8}$$

$$L_r = 1.95 \left(\frac{E}{F_y} \right) \frac{\sqrt{I_y J}}{S_x} \sqrt{2.36 \left(\frac{F_y}{E} \right) \frac{d S_x}{J} + 1} \quad \text{F9-9}$$



57

Double Angles

- F9.2 Lateral-Torsional Buckling

(b) Web legs in compression 

These provisions are a combination of double angle provisions and single angle provisions using

$$M_{cr} = \frac{1.95E}{L_b} \sqrt{I_y J} \left[B + \sqrt{1 + B^2} \right] \quad \text{F9-10}$$

and

$$B = -2.3 \left(\frac{d}{L_b} \right) \sqrt{\frac{I_y}{J}} \quad \text{F9-12}$$



58

Double Angles

- F9.2 Lateral-Torsional Buckling

- (b) Web legs in compression 

where M_n is determined using equations F10-2 and F10-3

(a) when $\frac{M_y}{M_{cr}} \leq 1.0$

$$M_n = \left(1.92 - 1.17 \sqrt{\frac{M_y}{M_{cr}}} \right) M_y \leq 1.5M_y \quad \text{F10-2}$$

(b) when $\frac{M_y}{M_{cr}} > 1.0$

$$M_n = \left(0.92 - \frac{0.17M_{cr}}{M_y} \right) M_{cr} \quad \text{F10-3}$$



59

Double Angles

- F9.3 Flange Local Buckling of Double-Angle Legs 

- (b) For double-angle flange legs use F10.3 with S_c referred to the compression flange.

- F9.4 Local Buckling of Double-Angle Web Legs in Flexural Compression 

- (b) For double-angle web legs use F10.3 with S_c taken as the elastic section modulus.



60

Single Angles

- F10.3 Leg Local Buckling

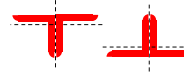

(b) For sections with noncompact legs

$$M_n = F_y S_c \left[2.43 - 1.72 \left(\frac{b}{t} \right) \sqrt{\frac{F_y}{E}} \right] \quad \text{F10-6}$$

(c) For sections with slender legs

$$M_n = F_{cr} S_c = \frac{0.71 E S_c}{\left(\frac{b}{t} \right)^2} \quad \text{F10-7.8}$$



The difference comes in the magnitude of the section modulus.

61

Example 4

- Determine the bending strength for a pair of equal leg A36 angles. Use a pair of 6x6x5/16 angles with no lateral restraint except at the supports.

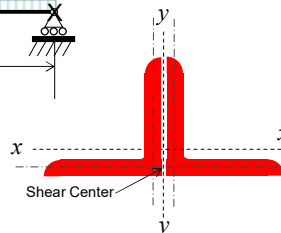
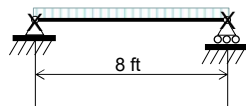

$$2 - 6 \times 6 \times \frac{5}{16}$$

$$A = 2(3.67) = 7.34 \text{ in.}^2$$

$$S_x = 2(2.95) = 5.9 \text{ in.}^3$$

$$I_x = 2(13.0) = 26.0 \text{ in.}^4$$

$$b = 6.0 \text{ in.}$$

$$t = 0.3125 \text{ in.}$$

$$\bar{x} = 1.60 \text{ in.}$$

$$J = 2(0.129) = 0.258 \text{ in.}^4$$



62

Example 4

- Determine the bending strength for a pair of equal leg A36 angles. Use a pair of 6x6x5/16 angles with no lateral restraint except at the supports.

If the gap between angles is zero

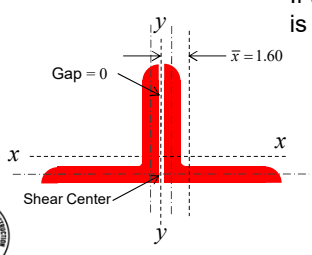

Gap = 0

$\bar{x} = 1.60$

Shear Center

$$I_y = 2 \left[13.0 + 3.67(1.60)^2 \right] = 44.8 \text{ in.}^4$$

$$r_y = \sqrt{\frac{44.8}{7.34}} = 2.47 \text{ in.}$$

63

Example 4

- F9.1 Yielding 

$$M_n = 1.5M_y = 1.5F_y S_x \quad \text{F9-5}$$

$$= 1.5(36)(5.90) = 1.5(212)$$

$$= 319 \text{ in.-kips}$$

- F9.4 Legs in Flexural Compression 

– F10.3 Leg Local Buckling (Table B4.1b Case 12)

$$\frac{b}{t} = \frac{6}{5/16} = 19.2 > \lambda_p = 0.54 \sqrt{\frac{E}{36}} = 15.3$$

Therefore the angle legs are noncompact

$$< \lambda_r = 0.91 \sqrt{\frac{E}{36}} = 25.8$$



64

Example 4

- F10.3(b) For sections with noncompact legs

$$M_n = F_y S_c \left(2.43 - 1.72 \left(\frac{b}{t} \right) \sqrt{\frac{F_y}{E}} \right) \quad \text{F10-6}$$

$$= 36(5.90) \left(2.43 - 1.72 \left(\frac{6}{5/16} \right) \sqrt{\frac{36}{29,000}} \right) = 269 \text{ in.-kips}$$

- Note that the $0.8S_c$ used for single angles is not used for double angles.



65

Example 4

- F9.2(b) for lateral-torsional buckling, web legs in compression if $L_b = 8.0$ ft.



and

$$B = -2.3 \left(\frac{d}{L_b} \right) \sqrt{\frac{I_y}{J}} = -2.3 \left(\frac{6.0}{8(12)} \right) \sqrt{\frac{44.8}{0.258}} = -1.89 \quad \text{F9-12}$$

$$M_{cr} = \frac{1.95E}{L_b} \sqrt{I_y J} \left[B + \sqrt{1 + B^2} \right] \quad \text{F9-10}$$

$$= \frac{1.95(29,000)}{12(8.0)} \sqrt{44.8(0.258)} \left[-1.89 + \sqrt{1 + (-1.89)^2} \right]$$

$$= 497 \text{ in.-kips}$$

$$M_y = F_y S_x = (36)(5.90) = 212 \text{ in.-kips} \quad \text{F9-3}$$



66

Example 4

- F10.2 for lateral-torsional buckling, web legs in compression

$$\frac{M_y}{M_{cr}} = \frac{212}{497} = 0.427 \leq 1.0$$

– Therefore use Eq. F10-2

$$M_n = \left(1.92 - 1.17 \sqrt{\frac{M_y}{M_{cr}}} \right) M_y \leq 1.5M_y$$

$$= \left(1.92 - 1.17 \sqrt{\frac{212}{497}} \right) (212) = 245 \text{ in.-kips} < 1.5M_y = 318 \text{ in.-kips}$$



67

Example 4

- Determine controlling limit state

Yielding

$$M_n = 319 \text{ in.-kips}$$

Local Buckling

$$M_n = 269 \text{ in.-kips}$$

Lateral-torsional Buckling, $L_b = 8.0 \text{ ft}$

$$M_n = 245 \text{ in.-kips}$$

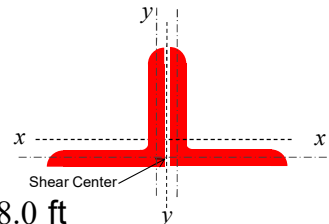

68

Example 4

- The strength for a single angle with span of 8.0 ft and no intermediate lateral support, Section F10.2(2), can be shown to be limited by lateral-torsional buckling giving

$$M_n = 98.2 \text{ in.-kips}$$

- So the two angles alone could carry

$$M_n = 2(98.2) = 196 \text{ in.-kips}$$

- Since this is less than the double angle limiting strength, $M_n = 245 \text{ in.-kips}$, the two angles must be connected to work together.



69

Example 4

- Again using the provisions from E6 considered earlier for the channels, determine the connection between angles

$$\frac{a}{r_i} = \frac{a}{r_z} = \frac{a}{1.19} \leq 0.75 \frac{L_b}{r_y} = 0.75 \left(\frac{L_b}{2.47} \right)$$
$$a \leq 0.361L_b$$

- Use 12 in. end welds and 2 intermediate welds



70

Example 4

- Now determine the strength if the stem is in tension

Note that the section properties remain unchanged but in addition, we need the section modulus to the compression flange

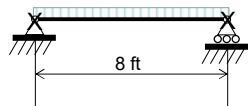

$$S_c = \frac{I_x}{y} = \frac{26.0}{1.60} = 16.3 \text{ in.}^3$$

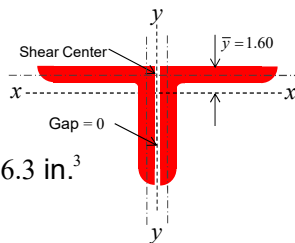

$$2 - 6 \times 6 \times \frac{5}{16}$$

$$S_x = 2(2.95) = 5.90 \text{ in.}^3$$

$$I_y = 44.8 \text{ in.}^4$$

$$Z_x = 2(5.26) = 10.52 \text{ in.}^3$$

$$r_y = 2.47 \text{ in.}$$

$$b = 6.0 \text{ in.}$$

$$t = 0.3125 \text{ in.}$$

$$\bar{y} = 1.60 \text{ in.}$$

$$J = 0.258 \text{ in.}^4$$



71

Example 4

- F9.1(a) Yielding

$$M_n = M_p = F_y Z = 36(10.52) = 379$$

$$\leq 1.6M_y = 1.6(36)(5.90) = 340 \text{ in.-kips} \quad \text{F9-1, F9-2}$$

- F9.3(b) Flange local buckling for double angle flange legs We already know the legs are noncompact
 - F10.3(b) leg local buckling is a function of the section modulus to the toe in compression

$$M_n = F_y S_c \left(2.43 - 1.72 \left(\frac{b}{t} \right) \sqrt{\frac{F_y}{E}} \right) \quad \text{F10-6}$$

$$= 36(16.3) \left(2.43 - 1.72 \left(\frac{6}{5/16} \right) \sqrt{\frac{36}{29,000}} \right) = 743 \text{ in.-kips}$$



72

Example 4

- F9.2 Lateral-Torsional Buckling

(a) For web legs in tension 

(1) When $L_b \leq L_p$

LTB does not apply

(2) When $L_p < L_b \leq L_r$

$$M_n = M_p - (M_p - M_y) \left[\frac{L_b - L_p}{L_r - L_p} \right] \quad (\text{F9-6})$$



73

Example 4

- F9.2 Lateral-Torsional Buckling

(a) For web legs in tension 

(3) When $L_b > L_r$

$$M_n = M_{cr} \quad (\text{F9-7})$$

where

$$M_{cr} = \frac{1.95E}{L_b} \sqrt{I_y J} \left[B + \sqrt{1 + B^2} \right] \quad (\text{F9-10})$$

and

$$B = 2.3 \left(\frac{d}{L_b} \right) \sqrt{\frac{I_y}{J}} \quad (\text{F9-11})$$



Note that with the stem in tension, B is positive

74

Example 4

- F9.2 Lateral-Torsional Buckling
(a) For web legs in tension 

$$L_p = 1.76r_y \sqrt{\frac{E}{F_y}} = 1.76(2.47) \sqrt{\frac{E}{36}} = 123 \text{ in.} \Rightarrow 10.3 \text{ ft.} \quad (\text{F9-8})$$

$$L_r = 1.95 \left(\frac{E}{F_y} \right) \frac{\sqrt{I_y J}}{S_x} \sqrt{2.36 \left(\frac{F_y}{E} \right) \frac{d S_x}{J} + 1} \quad (\text{F9-9})$$

$$= 1.95 \left(\frac{E}{36} \right) \frac{\sqrt{44.8(0.258)}}{5.90} \sqrt{2.36 \left(\frac{36}{E} \right) \frac{6.0(5.90)}{0.258} + 1}$$

$$= 1070 \text{ in.} \Rightarrow 89.3 \text{ ft}$$



75

Example 4

- Determine controlling limit state

Yielding

$$M_n = 340 \text{ in.-kips}$$

Local Buckling

$$M_n = 743 \text{ in.-kips}$$

Lateral-torsional Buckling,

$$L_b = 8.0 \text{ ft} < L_p = 10.3 \text{ ft}$$

Does not apply

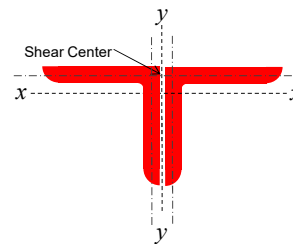

76

Example 4

- The strength for a single angle with span of 8.0 ft and no intermediate lateral support can be shown, Section F10.2(2)(b), to be limited by lateral-torsional buckling giving

$$M_n = 128 \text{ in.-kips}$$

- So the two angles alone could carry

$$M_n = 2(128) = 256 \text{ in.-kips}$$

- Since this is less than the double angle limiting strength, $M_n = 340$ in.-kips, the two angles must be connected to work together.



77

Example 4

- Again using the provisions from E6 considered earlier, determine the connection between angles

$$\frac{a}{r_i} = \frac{a}{r_z} = \frac{a}{1.19} \leq 0.75 \frac{L_b}{r_y} = 0.75 \left(\frac{L_b}{2.47} \right)$$

$$a \leq 0.361L_b$$

- Use 12 in. end welds and 2 intermediate welds



(Same as for legs up)

78

Example 4

- Summary



	M_n in.-kips	M_n in.-kips
Yielding	319	340
Local buckling	269	743
Lateral-torsional buckling, $L_b = 8$ ft	245	-



79

Crane Rail Girder

- The crane rail girders we will investigate are built-up from a W-shape and a channel cap.
 - We will look at determination of the strength of the built-up member.
 - We will not look at other important issues such as fatigue and economy.
 - Nor will we address required loading based on crane requirements/codes.



80

Crane Rail Girder

- Loading on the crane rail is both vertical and horizontal.
- Thus, it will induce bending and torsion into the crane rail girder.
- Normal practice is to treat the horizontal load as a bending load in the top built-up flange.



81

Crane Rail Girder

- For our example we will start with the gravity loading and consider the built-up shape.
 - Section F13.4 only addresses built-up shapes with members placed side-by-side.
 - Our built-up shape is a singly symmetric I-shape, thus we will be using Sections F4 and F5, depending on web slenderness.



82

Crane Rail Girder

- Section F4 includes singly symmetric I-shaped members with compact or noncompact webs.
- Section F5 includes singly symmetric I-shaped members with slender webs.
- Limit states
 - Compression flange yielding, lateral-torsional buckling, compression flange local buckling, and tension flange yielding



83

Crane Rail Girder

- These are the same provisions that apply for plate girders, members built-up from plates.
- For our crane rail girder example we will just look at the one *Specification* section that actually applies to the shapes that we have in our example.



84

Crane Rail Girder

- Crane rail loading will be applied as two equal forces at some given separation along the span. (AIST Tech. Report 13)
- Our girder will be assumed to be a simple span.
- Shear and moment can be determined through AISC *Manual* Table 3-23 Shears, Moments and Deflections.



85

Example 5

- Design a girder that can safely support the applied loads. The girder spans 30 ft with lateral supports at the ends only.

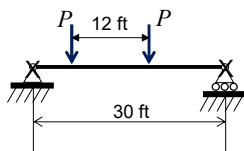

Vertical Wheel Load

$$P_{\text{bridge}} = 14.3 \text{ kips}$$

$$P_{\text{trolley+lift}} = 23.8 \text{ kips}$$

Horizontal Wheel Load

$$H = 2.53 \text{ kips}$$

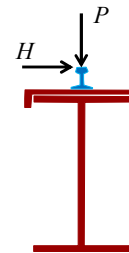

86

Example 5

- Worst case load placement
– *Manual* Table 3-23 Case 44

When $a < 0.586L$

$$M_{\max} = \frac{P}{2L} \left(L - \frac{a}{2} \right)^2 \quad \text{at } x = \frac{1}{2} \left(L - \frac{a}{2} \right)$$

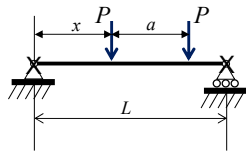

For our case,

$$a = 12.0 < 0.586(30.0) = 17.6 \text{ ft}, \quad x = \frac{1}{2} \left(30.0 - \frac{12.0}{2} \right) = 12.0 \text{ ft}$$

and the moment is

$$M_{\max} = \frac{P}{2L} \left(L - \frac{a}{2} \right)^2 = \frac{P}{2(30.0)} \left(30.0 - \frac{12.0}{2} \right)^2 = 9.6P$$



87

Example 5

- Worst case deflection can be approximated when the loads are symmetrically placed.

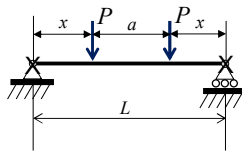

Δ_{\max} at midspan due to symmetrically placed loads

$$\begin{aligned} \Delta_{\max} &= \frac{Px}{24EI} (3L^2 - 4x^2) = \frac{P(9)}{24(29,000)I} (3(30)^2 - 4(9)^2)(1728) \\ &= \frac{53.1P}{I} \end{aligned}$$



88

Example 5

- Determining a trial section using *Manual* Table 1-19 for select combinations of W-shapes with cap channels

- Limit deflection to

$$\Delta_{\max} \leq \frac{L}{600} = \frac{30(12)}{600} = 0.60 \text{ in.}$$

- Therefore, for $P = 14.3 + 23.8 = 38.1$ kips

$$I_{\text{req}} \geq \frac{53.1(38.1)}{0.60} = 3370 \text{ in.}^4$$



89

Example 5

- Try a W27x94 with a C15x33.9 cap

(There are limited choices in this table)

W27x94 Table 1-1

$I_x = 3270 \text{ in.}^4$
 $I_y = 124 \text{ in.}^4$
 $Z_x = 278 \text{ in.}^3$
 $Z_y = 38.8 \text{ in.}^3$
 $A = 27.6 \text{ in.}^2$
 $d = 26.9 \text{ in.}$
 $b_f = 10.0 \text{ in.}$
 $t_f = 0.745 \text{ in.}$
 $t_w = 0.490 \text{ in.}$
 $J = 4.03 \text{ in.}^4$

C15x33.9 Table 1-5

$I_x = 315 \text{ in.}^4$
 $I_y = 8.07 \text{ in.}^4$
 $Z_x = 50.8 \text{ in.}^3$
 $Z_y = 6.19 \text{ in.}^3$
 $A = 10.0 \text{ in.}^2$
 $d = 15.0 \text{ in.}$
 $t_f = 0.650 \text{ in.}$
 $t_w = 0.400 \text{ in.}$
 $J = 1.01 \text{ in.}^4$
 $\bar{x} = 0.788 \text{ in.}$

Combined Table 1-19

$I_x = 4530 \text{ in.}^4$
 $I_y = 439 \text{ in.}^4$
 $Z_x = 357 \text{ in.}^3$
 $Z_y = 89.6 \text{ in.}^3$
 $A = 37.6 \text{ in.}^2$
 $S_x = S_{xt} = 268 \text{ in.}^3$
 $S_y = S_{yc} = 435 \text{ in.}^3$
 $r_x = 11.0 \text{ in.}$
 $J = 4.03 + 1.01 = 5.04 \text{ in.}^4$

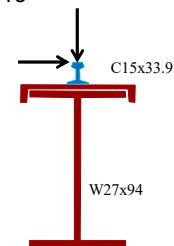

90

Example 5

- First check for slenderness
 - We know that all channels are compact.
 - We also know that all W-shapes except a select 10 have compact flanges.
 - Check web slenderness for our singly symmetric shape with Table B4.1b Case 16.

$$\lambda_p = \frac{\frac{h_c}{h_p} \sqrt{\frac{E}{F_y}}}{\left(0.54 \frac{M_p}{M_y} - 0.09\right)^2} \leq \lambda_r$$



91

Example 5

- Additional properties

$$h_c = 2(d - y_1 - t_f) = 2(26.9 - 16.92 - 0.745) = 18.5 \text{ in.}$$

$$h_p = 2(d - y_p - t_f) = 2(26.9 - 23.6 - 0.745) = 5.11 \text{ in.}$$

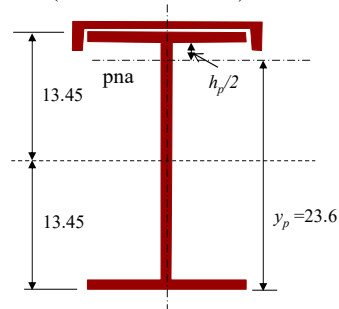
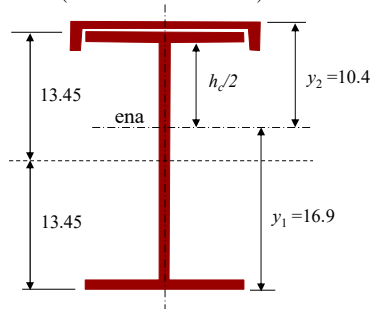

y_1 , y_2 , and y_p are all found in Table 1-19

92

Example 5

- Check web slenderness

$$\lambda_p = \frac{\frac{h_c}{h_p} \sqrt{E}}{\left(0.54 \frac{Z_x}{S_x} - 0.09\right)^2} = \frac{18.5 \sqrt{29,000}}{5.11 \sqrt{\frac{50}{50}}} = 220 \leq \lambda_r = 5.70 \sqrt{\frac{E}{F_y}} = 137$$

$$\frac{h_c}{t_w} = \frac{18.5}{0.490} = 37.8 < \lambda_p = \lambda_r = 137$$

- Therefore, the web is compact and we should be using Section F4.



93

Example 5

- Additional properties

Compression flange is composed of channel and top flange of W-shape

Centroid of compression flange from top

$$\bar{y} = \frac{10.0(0.788) + 7.45(0.40 + 0.745/2)}{10.0 + 7.45} = 0.781 \text{ in.}$$

Distance between centroids of flanges

$$h_o = 26.9 + 0.400 - 0.781 - 0.745/2 = 26.1 \text{ in.}$$

Moment of Inertia of compression flange

$$I_{y \text{ comp flange}} = I_{x \text{ channel}} + I_{\text{rect. flange}}$$

$$I_{yc} = 315 + \frac{0.745(10.0)^3}{12} = 377 \text{ in.}^4$$

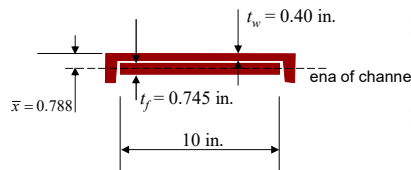

94

Example 5

- Additional properties

Compression flange plus 1/3
the web in compression

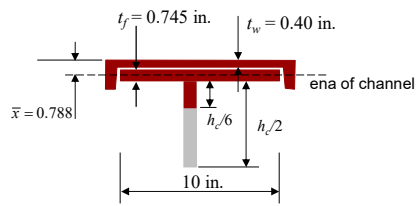

$$I_{yT} = 377 + \frac{(h_c/6)t_w^3}{12}$$

$$= 377 + \frac{(18.5/6)(0.490)^3}{12}$$

$$= 377 \text{ in.}^4$$

$$A = 10.0 + 10(0.745) + (18.5/6)(0.490)$$

$$= 10.0 + 7.45 + 1.51$$

$$= 19.0 \text{ in.}^2$$

$$r_t = \sqrt{\frac{I}{A}} = \sqrt{\frac{377}{19.0}} = 4.45 \text{ in.}$$

95

Example 5

- Determine if lateral-torsional buckling must be addressed.
- The unbraced length for the limit state of yielding

$$L_p = 1.1r_t \sqrt{\frac{E}{F_y}} = 1.1(4.45) \sqrt{\frac{29,000}{50}} = 118 \text{ in.} \quad \text{F4-7}$$

- Since our unbraced length, $L_b = 360 \text{ in.}$, is greater than L_p we must continue with lateral-torsional buckling.



96

Example 5

- Determine L_r

$$L_r = 1.95r_t \frac{E}{F_L} \sqrt{\frac{J}{S_{xc} h_o} + \sqrt{\left(\frac{J}{S_{xc} h_o}\right)^2 + 6.76\left(\frac{F_L}{E}\right)^2}} \quad \text{F4-8}$$

- Determine F_L

$$\frac{S_{xt}}{S_{xc}} = \frac{S_1}{S_2} = \frac{268}{435} = 0.616 < 0.7$$

therefore

$$F_L = F_y \frac{S_{xt}}{S_{xc}} = 50(0.616) = 30.8 \text{ ksi} \geq 0.5F_y = 25 \text{ ksi} \quad \text{F4-6b}$$



97

Example 5

- Determine L_r

$$L_r = 1.95r_t \frac{E}{F_L} \sqrt{\frac{J}{S_{xc} h_o} + \sqrt{\left(\frac{J}{S_{xc} h_o}\right)^2 + 6.76\left(\frac{F_L}{E}\right)^2}} \quad \text{F4-8}$$

$$= 1.95(4.45) \frac{29,000}{30.8} \sqrt{\frac{5.04}{435(26.1)} + \sqrt{\left(\frac{5.04}{435(26.1)}\right)^2 + 6.76\left(\frac{30.8}{29,000}\right)^2}}$$

$$= 465 \text{ in.}$$

- Thus, our unbraced length is between L_p and L_r



98

Example 5

- Consider F4.1 for the limit state of yielding

$$M_n = R_{pc} M_{yc} = R_{pc} F_y S_{xc} \quad \text{F4-1}$$

- Determine R_{pc} from Section F4.2

Since

$$\frac{I_{yc}}{I_y} = \frac{377}{439} = 0.86 > 0.23 \quad \text{and} \quad \frac{h_c}{t_w} \leq \lambda_{pw} \quad (\text{Compact web})$$

Then

$$R_{pc} = \frac{M_p}{M_{yc}} \quad \text{F4-9a}$$



99

Example 5

- Substituting into Eq 4-1 for R_{pc} yields

$$M_n = \frac{M_p}{M_{yc}} M_{yc} = M_p$$

- So for compression flange yielding

$$M_p = F_y Z_x = 50(357) = 17,850 \text{ in.-kips}$$

- Which means that

$$M_n = M_p = 17,850 \text{ in.-kips}$$



100

Example 5

- Continue with lateral-torsional buckling since

$$L_p = 118 < L_b = 30(12) = 360 \leq L_r = 465$$

then

$$M_n = C_b \left[R_{pc} M_{yc} - (R_{pc} M_{yc} - F_L S_{xc}) \left(\frac{L_b - L_p}{L_r - L_p} \right) \right] \leq R_{pc} M_{yc} \quad \text{F4-2}$$

But if we substitute for R_{pc} as before

$$M_n = C_b \left[M_p - (M_p - F_L S_{xc}) \left(\frac{L_b - L_p}{L_r - L_p} \right) \right] \leq M_p$$



101

Example 5

- So for our unbraced length of 30 ft

$$M_n = C_b \left[M_p - (M_p - F_L S_{xc}) \left(\frac{L_b - L_p}{L_r - L_p} \right) \right] \leq M_p$$

$$M_n = 1.0 \left[17,850 - (17,850 - 30.8(435)) \left(\frac{360 - 118}{465 - 118} \right) \right]$$

$$= 14,700 \text{ in.-kips}$$



102

Example 5

- Now consider F4.4 for tension flange yielding. Since

$$S_{xt} = 268 < S_{xc} = 435$$

then

$$M_n = R_{pt} M_{yt} = R_{pt} F_y S_{xt} \quad \text{F4-15}$$

since the web is compact and $I_{yc}/I_y > 0.23$

$$R_{pt} = \frac{M_p}{M_{yt}} \quad \text{F4-16a}$$



103

Example 5

- If we substitute for R_{pt} as we did for R_{pc} we get

$$M_n = R_{pt} M_{yt} = \frac{M_p}{M_{yt}} M_{yt} = M_p \quad \text{F4-15}$$

- So tension flange yielding is not a controlling limit state and

$$M_n = 14,700 \text{ in.-kips}$$



104

Example 5

- Now determine the flexural strength of the top flange for resisting the horizontal load.

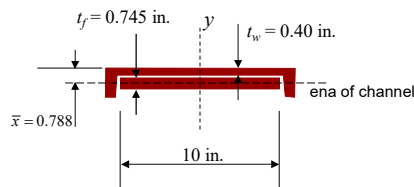

The elements are compact and the web provides continuous lateral support for the flange buckling down.

Therefore the only limit state to consider is yielding.

Determine Z and then M_p

$$Z = Z_{x \text{ channel}} + \frac{t_f b_f^2}{4} = 50.8 + \frac{0.745(10.0)^2}{4} = 69.4 \text{ in.}^3$$

$$M_p = F_y Z = 50(69.4) = 3470 \text{ in.-kips}$$



105

Example 5

- Determine the required moment strength

Vertical Wheel Load **LRFD** Load combination

$$P_{\text{bridge}} = 14.3 \text{ kips}$$

$$P_{\text{trolley+lift}} = 23.8 \text{ kips}$$

Horizontal Wheel Load

$$H = 2.53 \text{ kips}$$

$$P_u = 1.2(14.3) + 1.6(23.8) = 55.2 \text{ kips}$$

$$H_u = 1.6(2.53) = 4.05 \text{ kips}$$

$$w_{\text{self}} = 1.2(0.150) = 0.180 \text{ kips/ft}$$

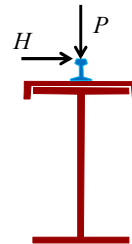
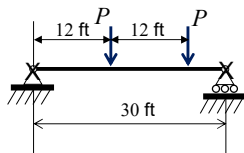

106

Example 5

- Determine the required moment strength
LRFD Load combination

Consider impact with an increase of 1.25 on moving load

$$M_{ux} = 9.6P_u + \frac{w_u L^2}{8} = 9.6(1.25(55.2)) + \frac{0.18(30)^2}{8} = 683 \text{ ft-kips}$$

$$M_{uy} = 9.6H_u = 9.6(1.25(4.05)) = 48.6 \text{ ft-kips}$$

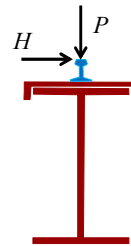
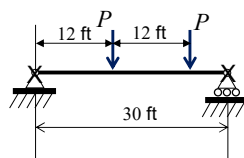

107

Example 5

- Since we are treating the load that induces torsion as a load producing horizontal bending in the top flange, we only need to use the biaxial bending interaction equations from Section H1.

$$\frac{M_{rx}}{M_{cx}} + \frac{M_{ry}}{M_{cy}} = \frac{683(12)}{0.9(14,700)} + \frac{48.6(12)}{0.9(3470)} = 0.806 \leq 1.0 \quad \text{H1-1b}$$

Our built-up crane girder works for flexure by LRFD



108

Example 5

- Determine the required moment strength

Vertical Wheel Load ASD Load combination

$$P_{\text{bridge}} = 14.3 \text{ kips}$$

$$P_{\text{trolley+lift}} = 23.8 \text{ kips}$$

Horizontal Wheel Load

$$H = 2.53 \text{ kips}$$

$$P_u = 14.3 + 23.8 = 38.1 \text{ kips}$$

$$H_u = 2.53 \text{ kips}$$

$$w_{\text{self}} = 0.150 \text{ kips/ft}$$

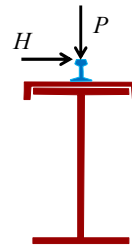
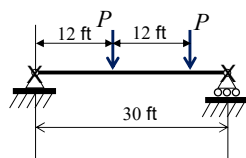

109

Example 5

- Determine the required moment strength

ASD Load combination

Consider impact with an increase of 1.25 on moving load

$$M_{ux} = 9.6P_u + \frac{w_u L^2}{8} = 9.6(1.25(38.1)) + \frac{0.15(30)^2}{8} = 474 \text{ ft-kips}$$

$$M_{uy} = 9.6H_u = 9.6(1.25(2.53)) = 30.4 \text{ ft-kips}$$

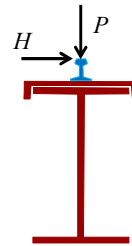
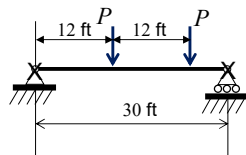

110

Example 5

- Since we are treating the load that induces torsion as a load producing bending in the top flange, we only need to use the biaxial bending interaction equations from Section H1.

$$\frac{M_{rx}}{M_{cx}} + \frac{M_{ry}}{M_{cy}} = \frac{474(12)}{(14,700/1.67)} + \frac{30.4(12)}{(3470/1.67)} = 0.822 \leq 1.0 \text{ H1-1b}$$

Our built-up crane girder works for flexure by **ASD**



111

Example 5

- Check shear by **LRFD**
 - From Manual Table 3-6 for the W27x94
 $\phi V_n = 395$ kips
 - From Manual Table 3-8 for the C15x33.9
 $\phi V_n = 117$ kips
 - If the shear was equal to the total load

$$2(55.2) + 0.18(30) = 116 \text{ kips} < \phi V_n = 395 \text{ kips}$$

$$2(4.05) = 8.10 \text{ kips} < \phi V_n = 117 \text{ kips}$$

Thus, shear is obviously OK

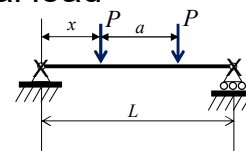

112

Example 5

- Check shear by **ASD**
 - From Manual Table 3-6 for the W27x94
 $V_n/\Omega = 264$ kips
 - From Manual Table 3-8 for the C15x33.9
 $V_n/\Omega = 77.6$ kips
 - If the shear was equal to the total load

$$2(38.1) + 0.15(30) = 80.7 \text{ kips} < \phi V_n = 264 \text{ kips}$$

$$2(2.53) = 5.06 \text{ kips} < \phi V_n = 77.6 \text{ kips}$$

Thus, shear is obviously OK

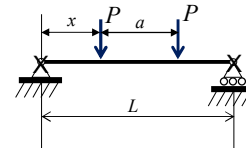

113

Example 5

- Another important consideration is found in Section J10.4 Web Sidesway Buckling.
- Since relative lateral movement between the loaded compression flange and the tension flange is not restrained, this limit state must be considered.



114

Example 5

- J10.4(b) If the compression flange is not restrained against rotation,

– when

$$\frac{h/t_w}{L_b/b_f} = \frac{49.5}{30(12)/10.0} = 1.38 < 1.7$$

$$R_n = \frac{C_r t_w^3 t_f}{h^2} \left[0.4 \left(\frac{h/t_w}{L_b/b_f} \right)^3 \right] \quad \text{J10-7}$$



115

Example 5

- By definition

$$\text{If } M_u = 683(12) = 8,200 < M_y = 50(268) = 13,400 \text{ in.-kips}$$

$$C_r = 960,000 \text{ ksi}$$

- Then

$$R_n = \frac{C_r t_w^3 t_f}{h^2} \left[0.4 \left(\frac{h/t_w}{L_b/b_f} \right)^3 \right] = 960,000 \left(\frac{0.49}{(49.5)^2} \right) (0.745) \left[0.4(1.38)^3 \right] \quad \text{J10-7}$$

$$= 150 \text{ kips}$$



116

Example 5

- The maximum factored wheel load with impact
- For LRFD
$$R_u = 1.25(55.2) = 69.0 < \phi R_n = 0.85(150) = 128 \text{ kips}$$
- For ASD
$$R_u = 1.25(38.1) = 47.6 < R_n / \Omega = (150 / 1.76) = 85.2 \text{ kips}$$
- Therefore web sidesway buckling strength is sufficient.



117

Example 5

- Connection between W-shape and channel
 - AISC Design Guide 7 *Industrial Building Design* recommends using continuous fillet welds.
 - *Specification* Table J2.4 gives a minimum weld size, based on the minimum $t_w = 0.400$ in., of 3/16 in.



118

Example 5

- Connection between W-shape and channel
 - There are several ways to assess this connection.
 - One simple way is to assume that the compressive force in the channel at the point of maximum moment is the yield stress times the area, thus

$$C_c = 50(10.0) = 500 \text{ kips}$$



119

Example 5

- Connection between W-shape and channel
 - The shortest distance from the maximum moment to point of zero moment (support) is 12 ft.
 - Weld strength over that distance,

$$\phi R_n = 1.392Dl = 1.392(3)(12(12))(2) = 1200 \text{ kips}$$

$$1200 \text{ kips} > C_c = 50(10.0) = 500 \text{ kips}$$



120

Example 5

- Connection between W-shape and channel
 - Thus, connect the W27x94 and C15x33.9 with a continuous 3/16 fillet weld on each side over the full span.



121

Example 5

- The W27x94 with C15x33.9 channel cap will be acceptable for the given loading by **ASD** or **LRFD**
- A W27x131 can be shown to also be adequate with a 3.1 pound/ft penalty
- It is likely that the W27x131 is the more economical solution

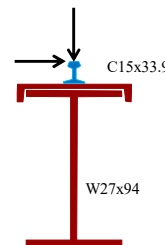

122

Summary

- We have looked at several types of members built-up from multiple rolled shapes.
- The provisions of Section F13.4 plus several other sections in Chapter F were sufficient to determine member strength.
- Connection of individual members is critical in forcing the built-up member to behave as one member.



123

References

- Fisher, J. (2019), *Industrial Building Design*, AISC Design Guide 7, 3rd Edition, American Institute of Steel Construction, Chicago.
- AIST (2003), *Guide for the Design and Construction of Mill Buildings*, AIST TR-13, Association for Iron and Steel Technology, Warrendale, PA.



124

AISC | Questions?



**Smarter.
Stronger.
Steel.**

PDH Certificates

- You will receive an email on how to report attendance from: registration@aisc.org.
- Be on the lookout: Check your spam filter! Check your junk folder!
- Completely fill out online form. Don't forget to check the boxes next to each attendee's name!



**Smarter.
Stronger.
Steel.**



PDH Certificates

- Reporting site (URL will be provided in the forthcoming email).
- Username: Same as AISC website username.
- Password: Same as AISC website password.



AISC | Thank you.

