

AISC Live Webinars

Thank you for joining our live webinar today.
We will begin shortly. Please standby.

Brittle Fracture: Another View
April 19, 2022



AISC Live Webinars

Today's live webinar will begin shortly. Please stand by.

Today's audio will be broadcast through the internet. Please be sure to turn up the volume on your speakers.

Please type any questions or comments in the Q&A window.



AISC Live Webinars

AIA Credit

AISC is a Registered Provider with The American Institute of Architects Continuing Education Systems (AIA/CES). Credit(s) earned on completion of this program will be reported to AIA/CES for AIA members. Certificates of Completion for both AIA members and non-AIA members are available upon request.

This program has been submitted with AIA/CES for continuing professional education. As such, it does not include content that may be deemed or construed to be an approval or endorsement by the AIA of any material of construction or any method or manner of handling, using, distributing, or dealing in any material or product.

Questions related to specific materials, methods, and services will be addressed at the conclusion of this presentation.



AISC Live Webinars

Copyright Materials

This presentation is protected by US and International Copyright laws. Reproduction, distribution, display and use of the presentation without written permission of AISC is prohibited.

© The American Institute of Steel Construction 2022

The information presented herein is based on recognized engineering principles and is for general information only. While it is believed to be accurate, this information should not be applied to any specific application without competent professional examination and verification by a licensed professional engineer. Anyone making use of this information assumes all liability arising from such use.



AISC Live Webinars

Course Description

Brittle Fracture: Another View
April 19, 2022

This lecture examines brittle fracture from a holistic perspective, considering the many variables that lead to brittle fracture. Four case studies are used to illustrate the effect of these variables: the World War II Liberty Ships, the Silver Bridge, the Martha Ingram barge and the Hoan Bridge. The interaction of fatigue loading and fracture will be reviewed. Finally, 48 practical ideas that will increase the resistance of a structure to brittle fracture are presented.



AISC Live Webinars

Learning Objectives – Submitted for AIA CE Credit

- Define brittle fracture.
- Explain the significance of brittle fracture.
- List factors that affect brittle fracture.
- List ways to design to prevent brittle fracture.



Brittle Fracture: Another View

April 19, 2022

Duane K. Miller, PE, ScD, The Lincoln Electric Company



Brittle Fracture: Another View Outline

- ➔ • Definition of brittle fracture
- Significance of brittle fracture
- Factors affecting brittle fracture
- Case studies involving brittle fracture
- Designing to prevent brittle fracture



COMMENTARY GLOSSARY

Brittle fracture.

Abrupt cleavage with little or no prior ductile deformation.

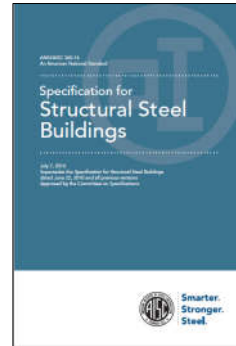

9

Dieter: MECHANICAL METALLURGY

Brittle fracture in metals is characterized by a rapid rate of crack propagation, with no gross deformation and very little micro-deformations. The tendency for brittle fracture is increased with decreasing temperature, increasing strain rate, and triaxial stress conditions (usually produced by a notch).



10

Barsom/Rolfe: FRACTURE AND FATIGUE CONTROL IN STRUCTURES

Brittle fracture is a type of failure in structural materials that usually occurs without prior plastic deformation and at extremely high speeds (as fast as 7000 ft/s [210 m/s] in steels). The fracture is usually characterized by a flat cleavage fracture surface...and at average stress levels below those of general yielding.



11

Gensamer: STRENGTH OF METALS UNDER COMBINED STRESS

It is well known that a metal may be ductile under one set of conditions and brittle under another. Ductility and brittleness, then are properties that must be considered as referring to some particular set of testing or service conditions.

12

Barsom/Rolfe: FRACTURE AND FATIGUE CONTROL IN STRUCTURES

Most structural materials exhibit considerable strain (deformation) before reaching the tensile or ultimate strength, σ_{tens}In contrast, brittle materials exhibit almost no deformation before fracture....However, under conditions of low temperature, rapid loading and/or high constraint...even ductile materials may not exhibit any deformation before fracture.

13

Barsom/Rolfe: FRACTURE AND FATIGUE CONTROL IN STRUCTURES

Most structural materials ^{like steel} exhibit considerable strain (deformation) before reaching the tensile or ultimate strength, σ_{tens}In contrast, brittle materials ^{like cast iron} exhibit almost no deformation before fracture....However, under conditions of low temperature, rapid loading and/or high constraint...even ductile materials ^{like steel} may not exhibit any deformation before fracture.

14

Barsom/Rolfe: FRACTURE AND FATIGUE CONTROL IN STRUCTURES

...the science of *fracture mechanics* can be used to describe quantitatively the tradeoffs among stress, material fracture toughness, and flaw size so that the designer can determine the importance of each during the *design* process.

15

Basic Fracture Mechanics

Material fracture toughness (K_{Ic})

Stress (σ)

Flaw size (a)

$$K_{Ic} \geq 1.12 \sigma (\pi a)^{0.5}$$

16

Basic Fracture Mechanics

$K_{IC} \geq 1.12 \sigma (\pi a)^{0.5}$

If K_{IC} is high enough, σ can be $> F_u$.

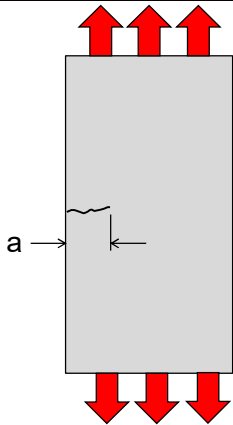

⊘ Net section will eventually control.

17

Basic Fracture Mechanics

$K_{IC} \geq 1.12 \sigma (\pi a)^{0.5}$

If K_{IC} is high enough, a can be $> b/2$.

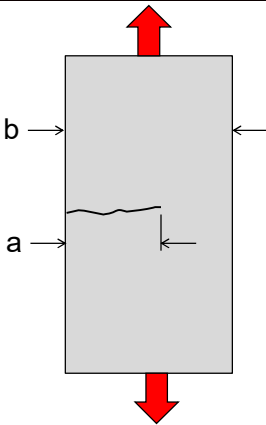

⊘ Net section will eventually control.

18

Basic Fracture Mechanics

$K_{IC} \geq 1.12 \sigma (\pi a)^{0.5}$

If $a = 0$, σ can be infinite, even if K_{IC} is low.

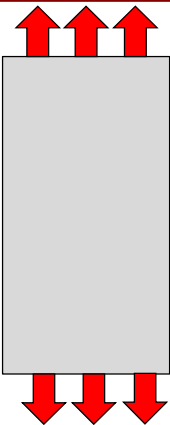

⊘ Gross section will eventually control.

19

Brittle Fracture: Another View

Outline

- Definition of brittle fracture
- ➔ • Significance of brittle fracture
- Factors affecting brittle fracture
- Case studies involving brittle fracture
- Designing to prevent brittle fracture



Dieter: MECHANICAL METALLURGY

Brittle fracture is to be avoided at all cost, because it occurs without warning and usually produces disastrous consequences.



21

Barsom/Rolfe: FRACTURE AND FATIGUE CONTROL IN STRUCTURES



Because it is very difficult to fabricate large welded structures without introducing some type of notch, flaw, or stress concentration, the design engineer must be aware of the effect of notches and constraint on material behavior.



22

Barsom/Rolfe: FRACTURE AND FATIGUE CONTROL IN STRUCTURES



Thus, in addition to the material properties such as yield strength, modulus of elasticity, and tensile strength, there is another very important material property, namely notch toughness that may be related to the behavior of a structure. Notch toughness is defined as the ability of a material to absorb energy in the presence of a sharp notch, often when subjected to an impact load.



23

Brittle Fracture: Another View

Outline

- Definition of brittle fracture
- Significance of brittle fracture
- ➔ • Factors affecting brittle fracture
- Case studies involving brittle fracture
- Designing to prevent brittle fracture



The Holy Trinity

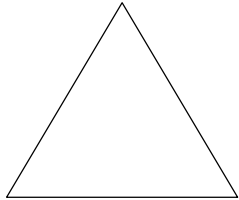

25

The Unholy Trinity

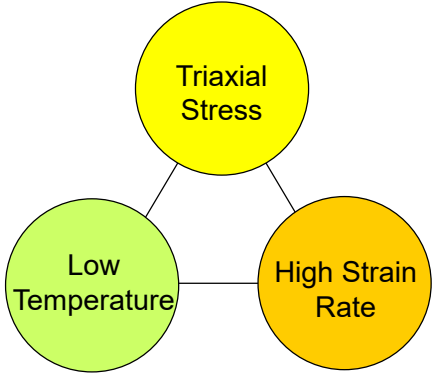

26

AISC 360-16 Specifications for Structural Steel Buildings

Commentary A3.1a

For especially demanding service conditions such as **structures exposed to low temperatures**, particularly **those with impact loading**, the specification of steels with superior notch toughness may be warranted.

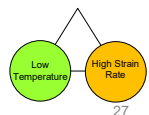

27

STEEL CONSTRUCTION MANUAL 15th Edition

A triaxial state-of-stress can also result from uniaxial loading when notches or geometric discontinuities are present. A triaxial state-of-stress **will cause the yield stress of the material to increase above its nominal value, resulting in brittle fracture by cleavage**, rather than ductile shear deformations.

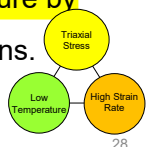

page 2-38
28

Dieter: MECHANICAL METALLURGY

Brittle fracture in metals is characterized by a rapid rate of crack propagation, with no gross deformation and very little micro-deformations.....The tendency for brittle fracture is increased with **decreasing temperature**, **increasing strain rate**, and **triaxial stress conditions (usually produced by a notch)**.

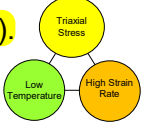

29

Barsom/Rolfe: FRACTURE AND FATIGUE CONTROL IN STRUCTURES

Most structural materials exhibit considerable strain (deformation) before reaching the tensile or ultimate strength, σ_{tens}In contrast, brittle materials exhibit almost no deformation before fracture....However, under **conditions of low temperature**, **rapid loading** and/or **high constraint**...even ductile materials may not exhibit any deformation before fracture.

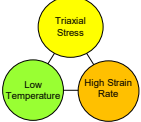

30

The Unholy Trinity

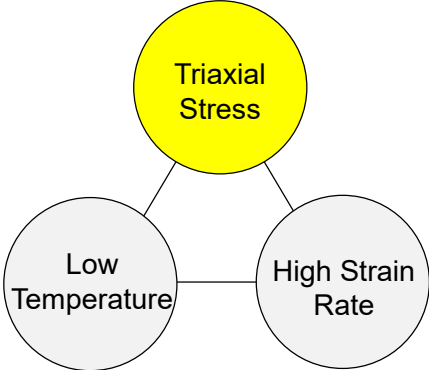

31

Dieter: MECHANICAL METALLURGY

7-11 NOTCH EFFECTS

...However, **the chief effect of the notch is not in introducing a stress concentration but in producing a triaxial state of stress at the notch.**



32

Dieter: MECHANICAL METALLURGY

In summary, a notch increases the tendency for brittle fracture **in four important ways:**

- ➔ • By producing high local stresses
- By introducing a triaxial tensile state of stress
- By producing high local strain hardening and cracking
- By producing a local magnification to the strain rate

33

Two things:

- $A_{net} < A_{gross}$
- Stress is not uniform

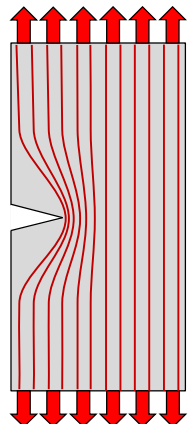

34

Dieter: MECHANICAL METALLURGY

In summary, a notch increases the tendency for brittle fracture **in four important ways:**

- By producing high local stresses
- ➔ • By introducing a triaxial tensile state of stress
- By producing high local strain hardening and cracking
- By producing a local magnification to the strain rate

35

Thin Plate

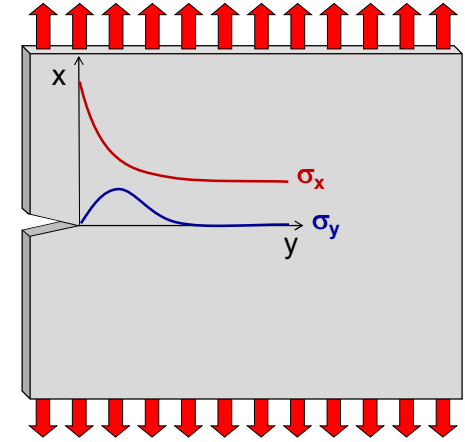

36

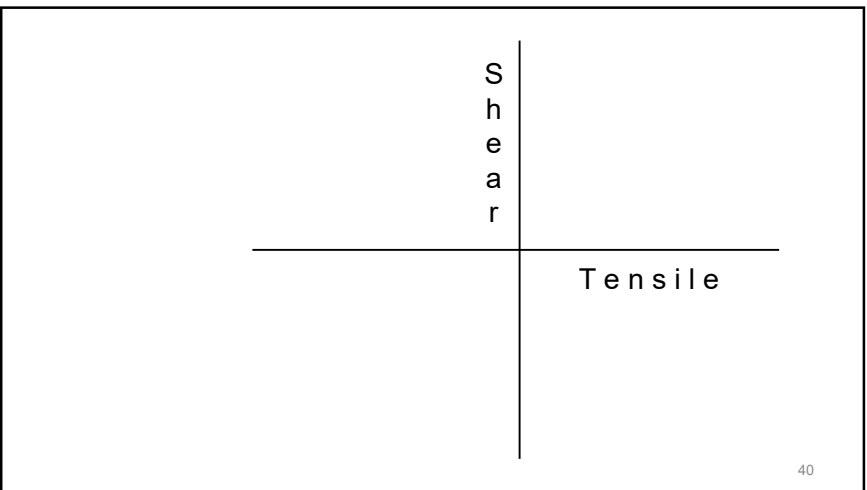
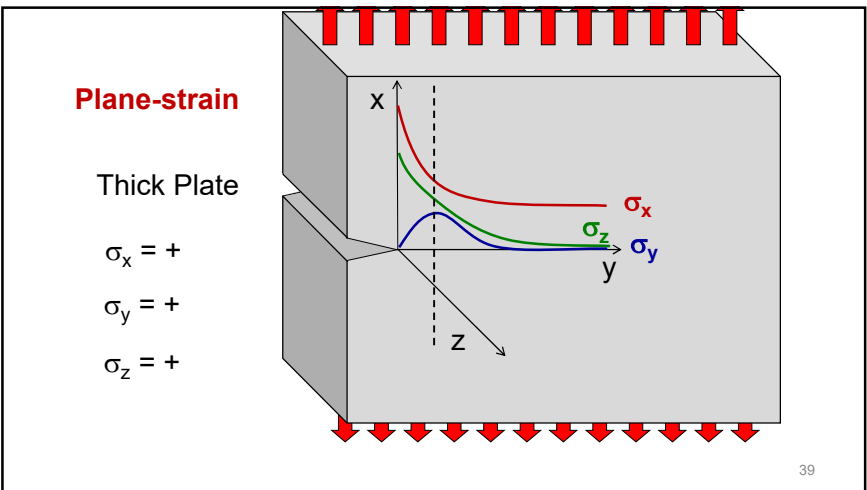
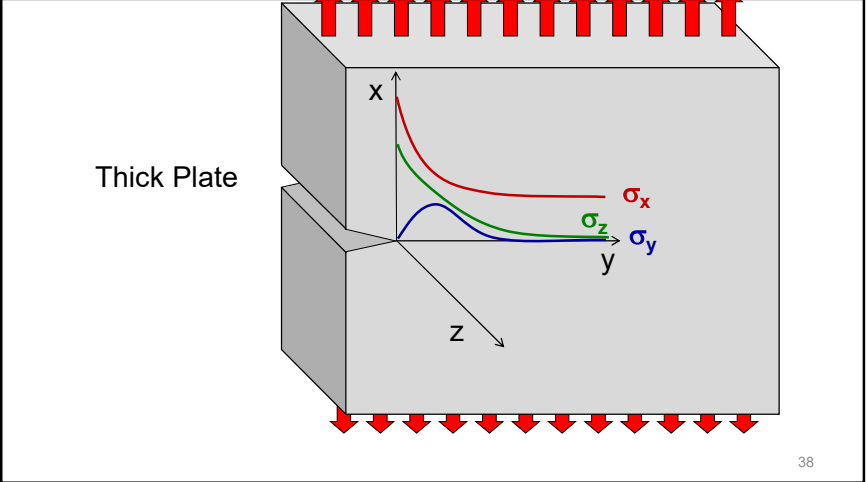
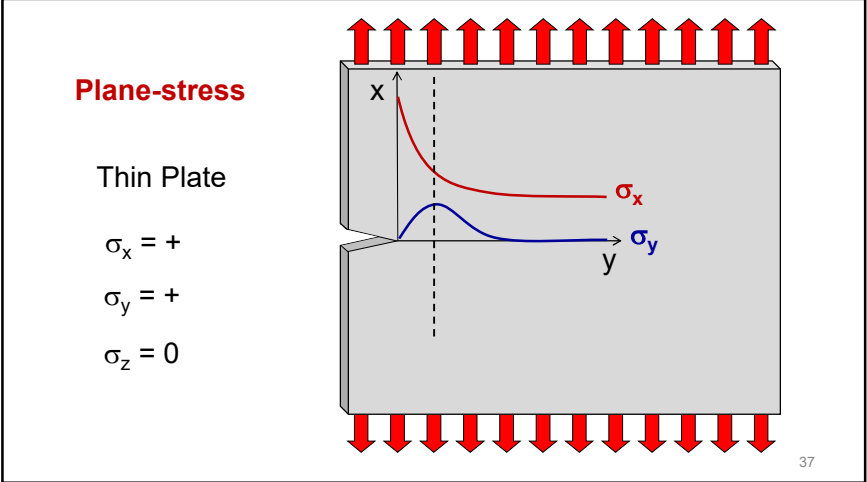

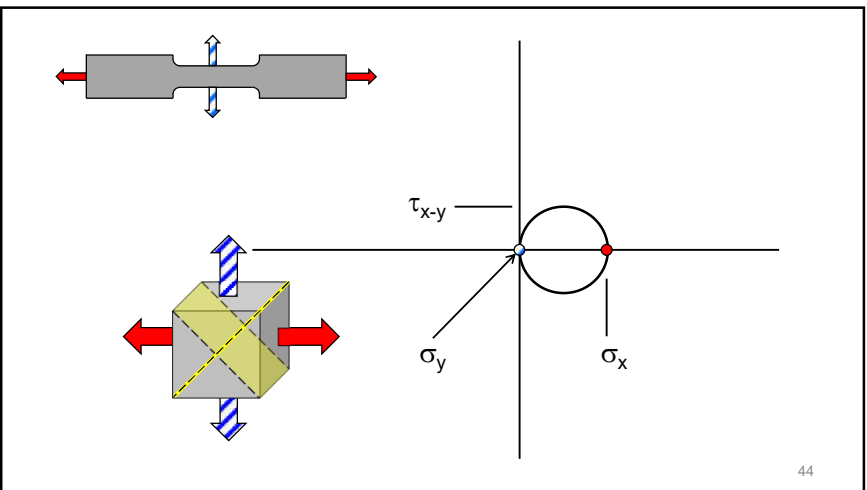
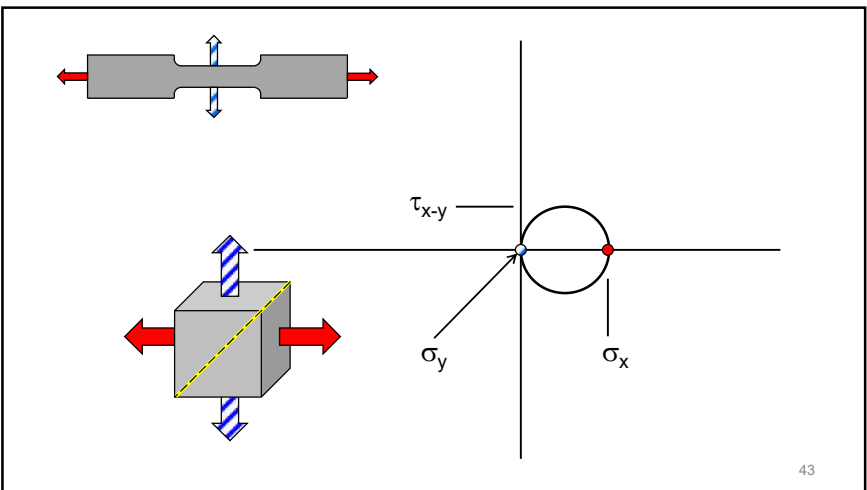
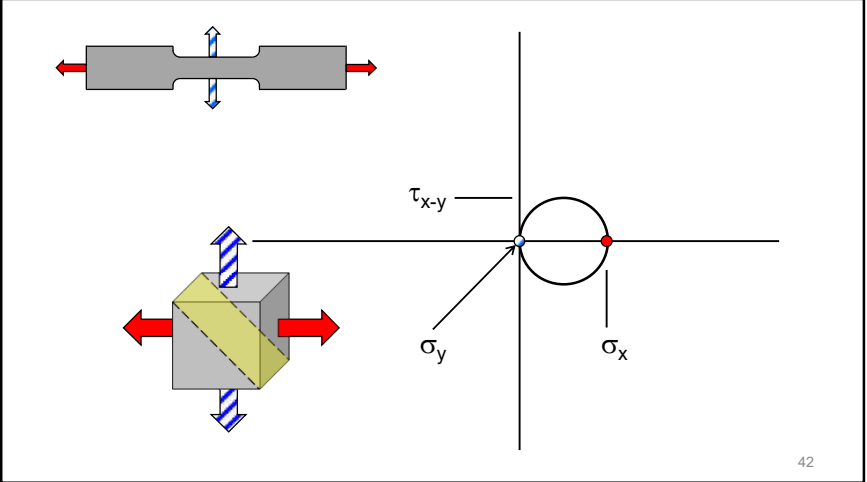
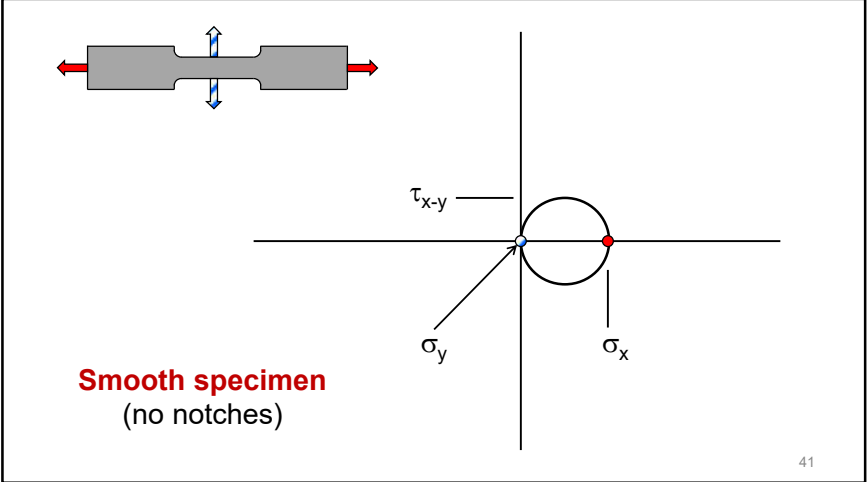

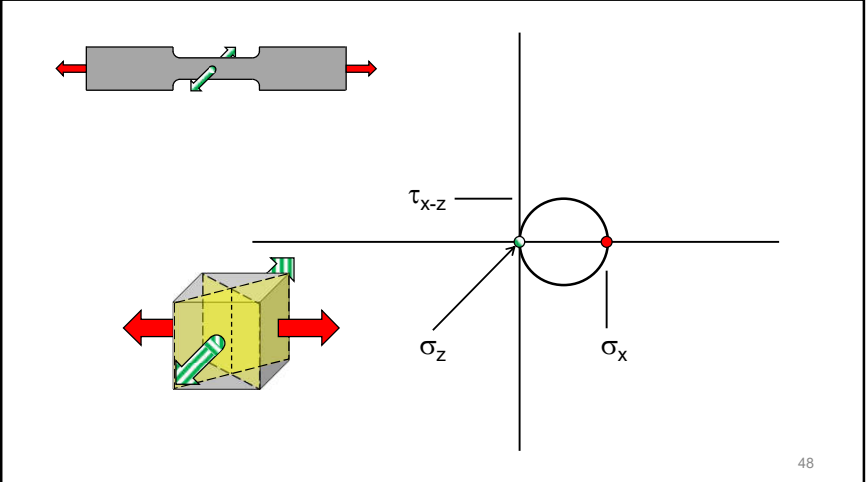
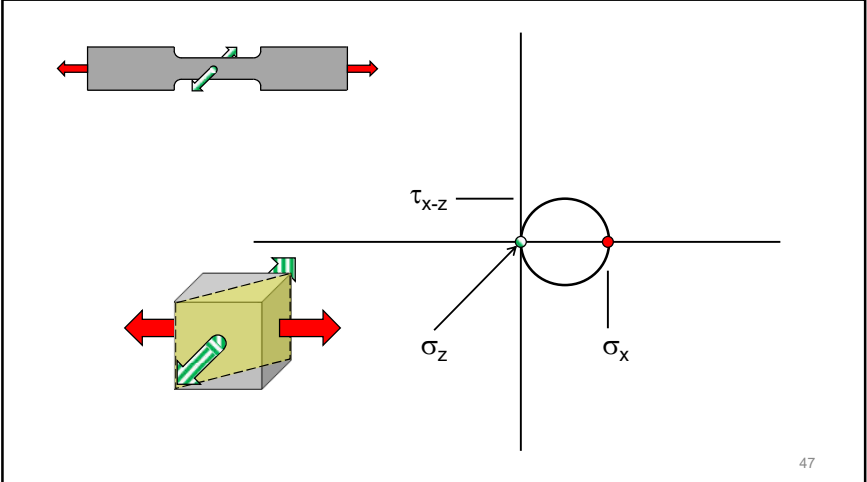
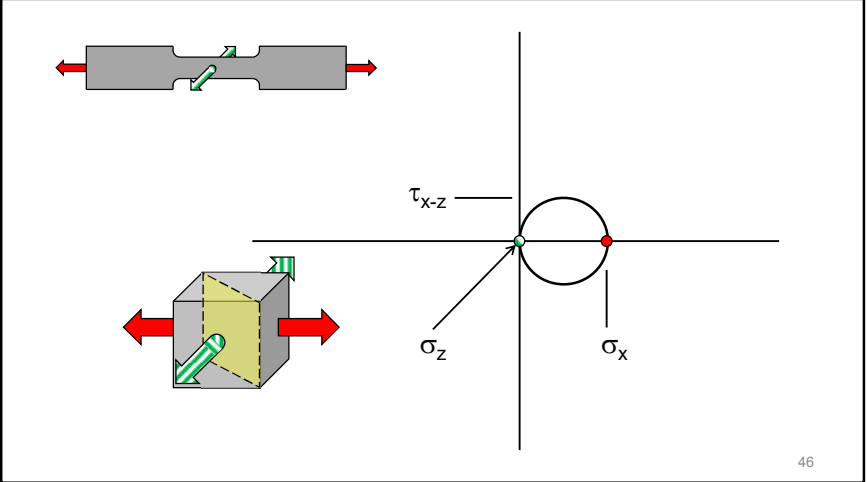
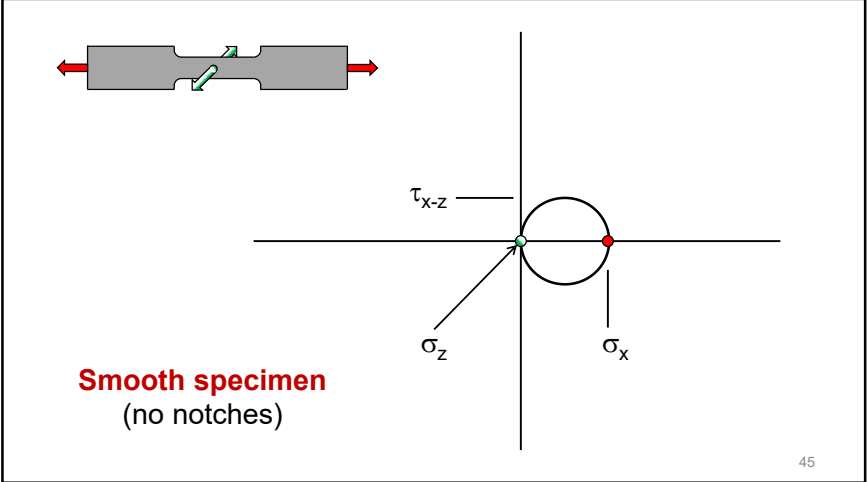

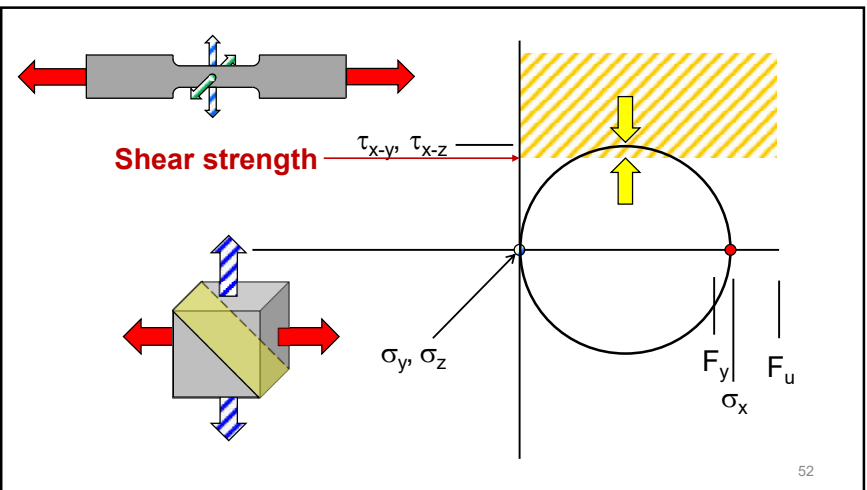
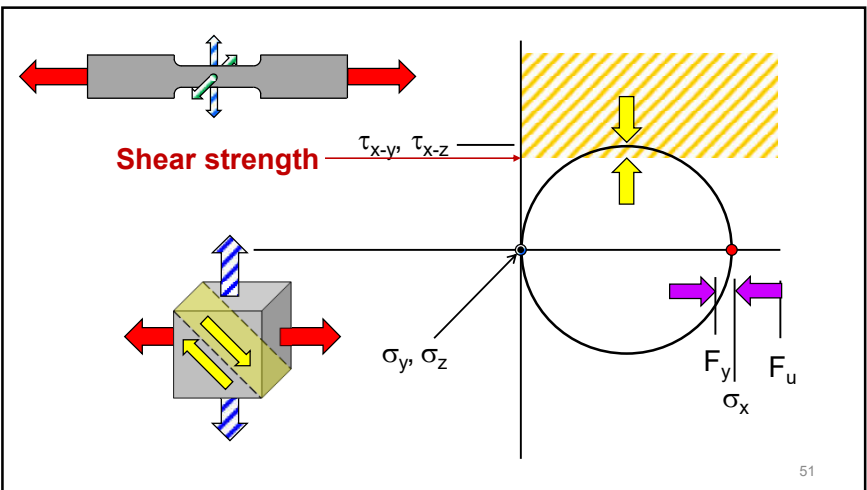
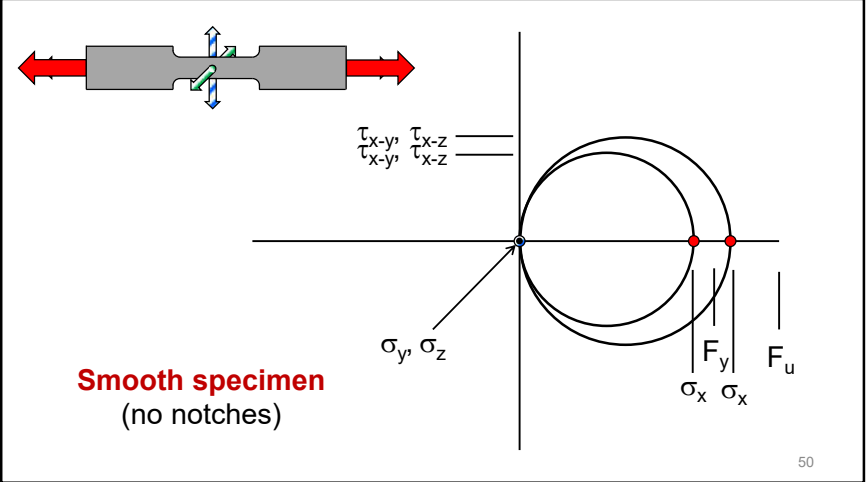
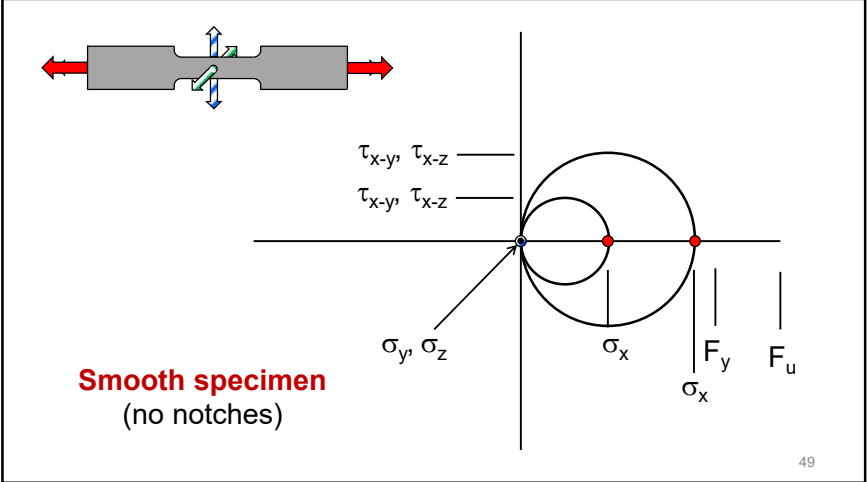

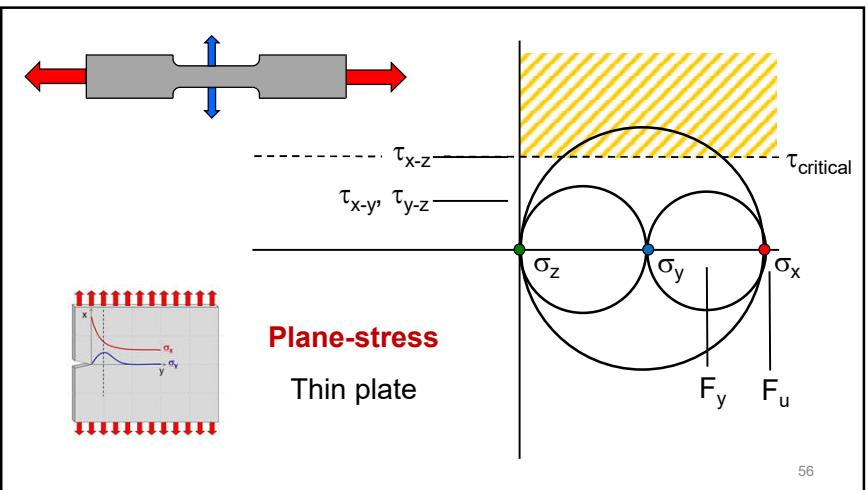
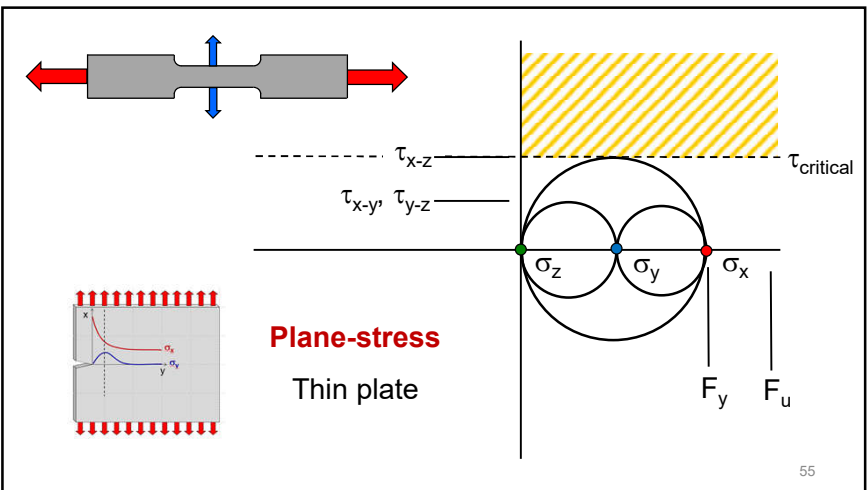
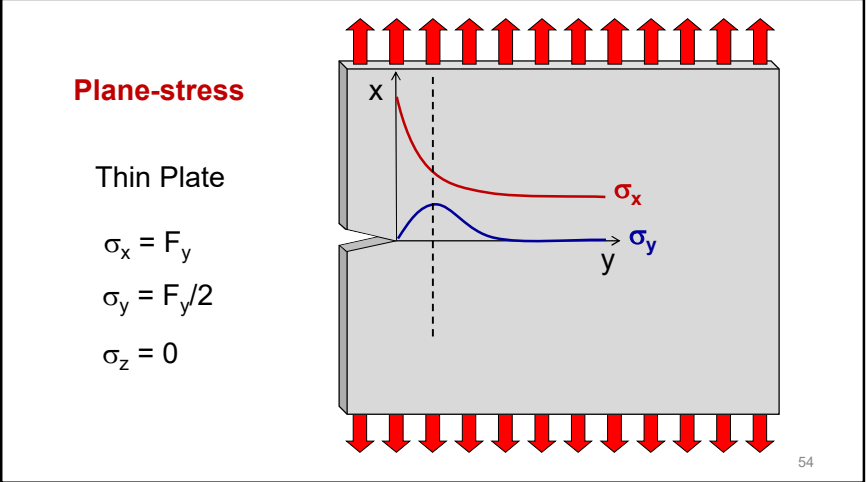
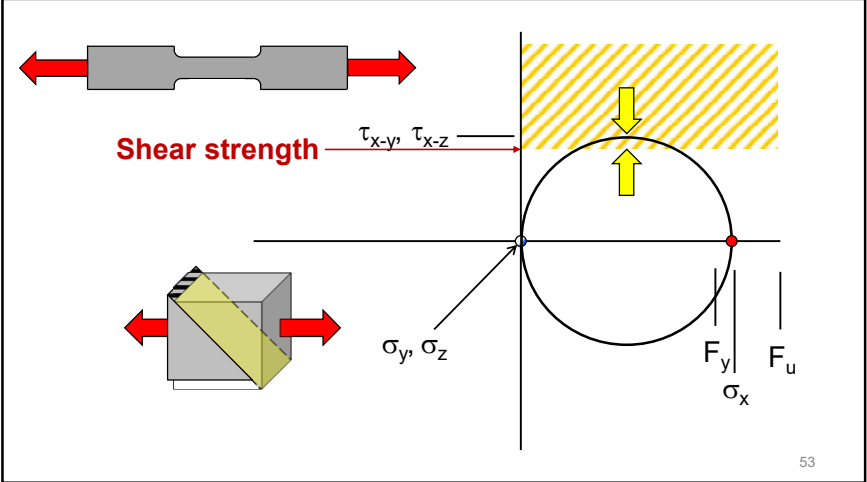

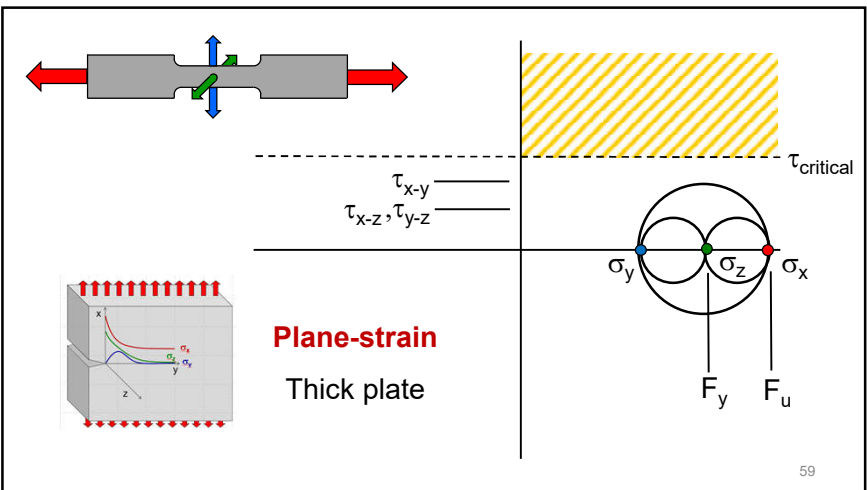
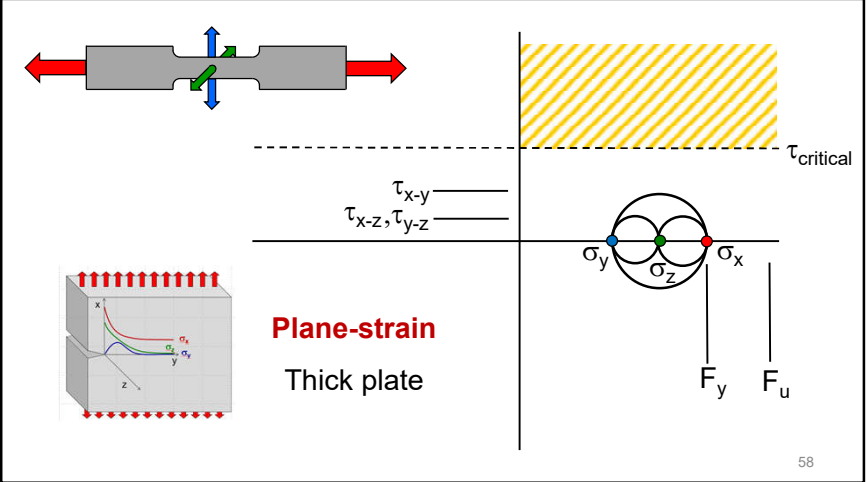
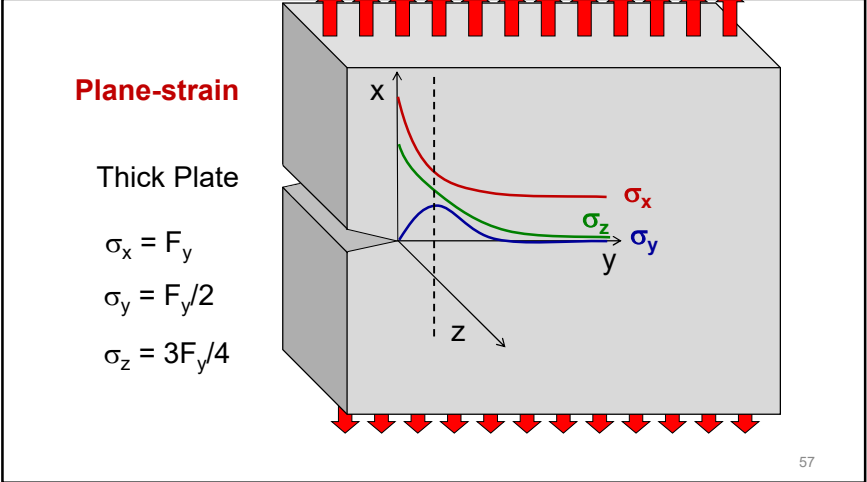

- Dieter: MECHANICAL METALLURGY
- In summary, a notch increases the tendency for brittle fracture **in four important ways:**
- By producing high local stresses
 - By introducing a triaxial tensile state of stress
 - ➔ • By producing high local strain hardening and cracking
 - By producing a local magnification to the strain rate
- 60

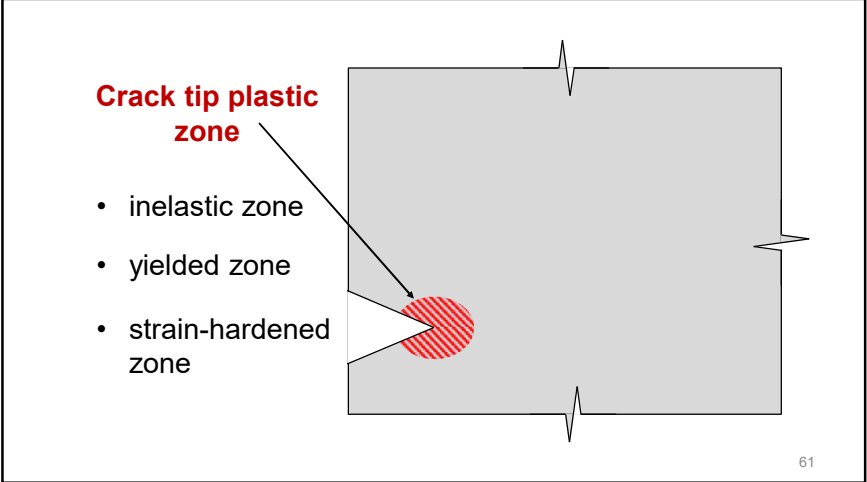

DEFORMATION AND FRACTURE MECHANICS OF ENGINEERING MATERIALS by Hertzberg

The ability of a component to plastically deform in the vicinity of a crack tip is the **saving grace** of countless engineering structures.

62

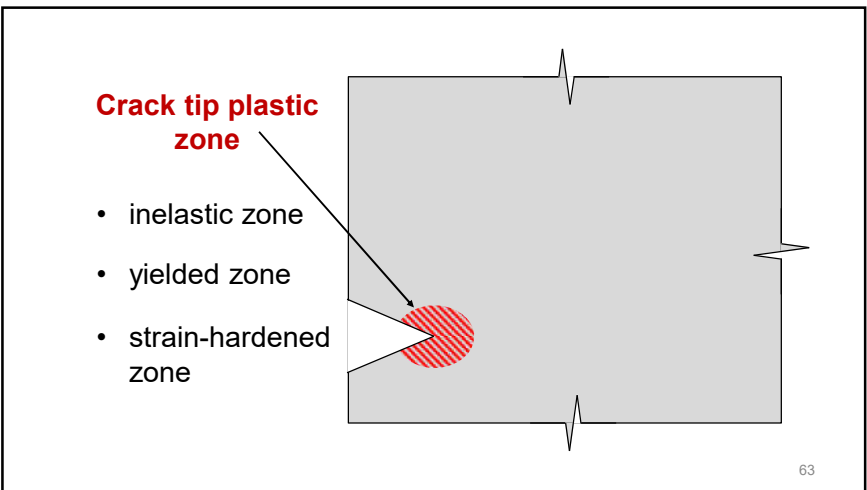

Dieter: MECHANICAL METALLURGY

In summary, a notch increases the tendency for brittle fracture **in four important ways:**

- By producing high local stresses
- By introducing a triaxial tensile state of stress
- By producing high local strain hardening and cracking
- ➔ • By producing a local magnification to the strain rate

64

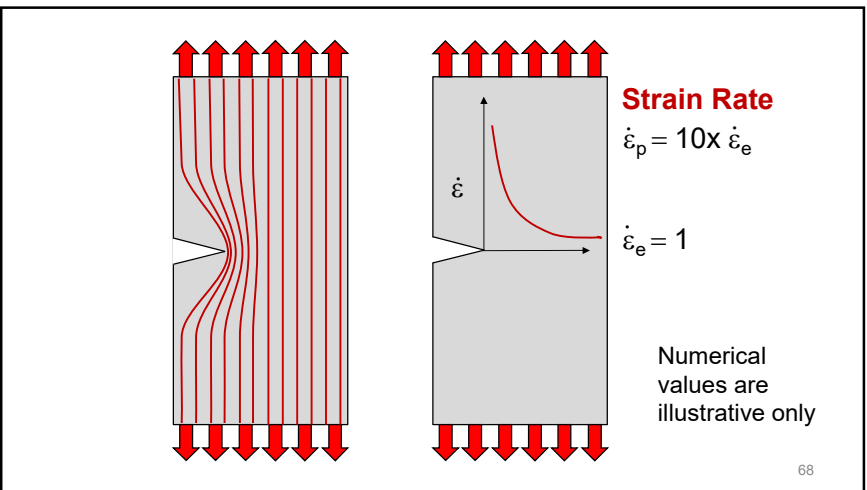
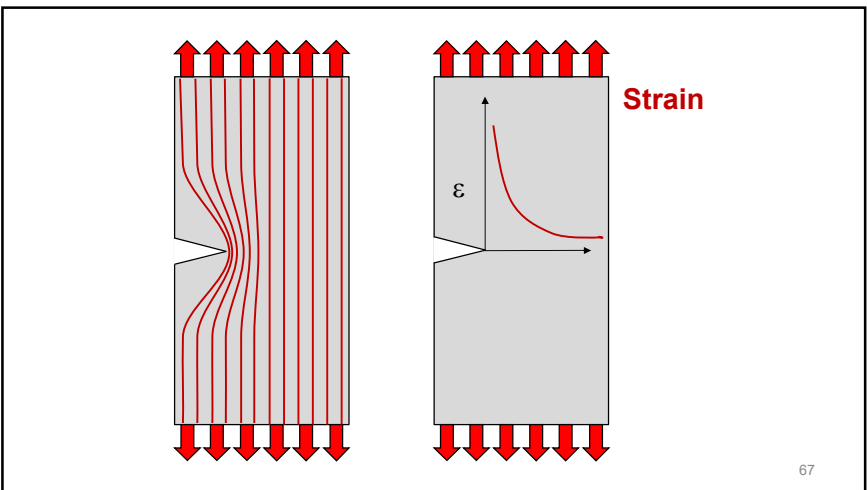
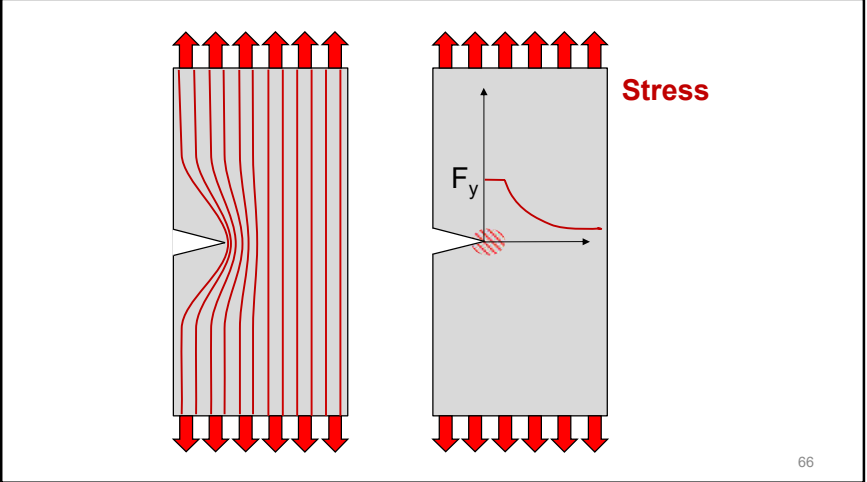
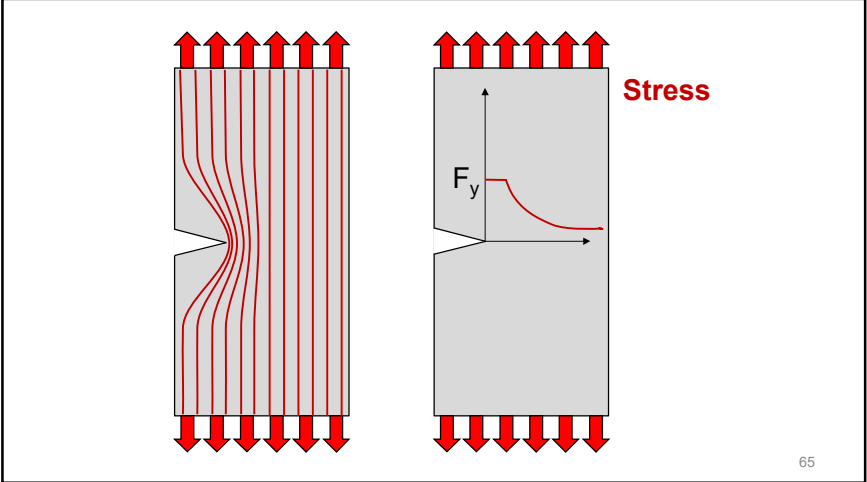

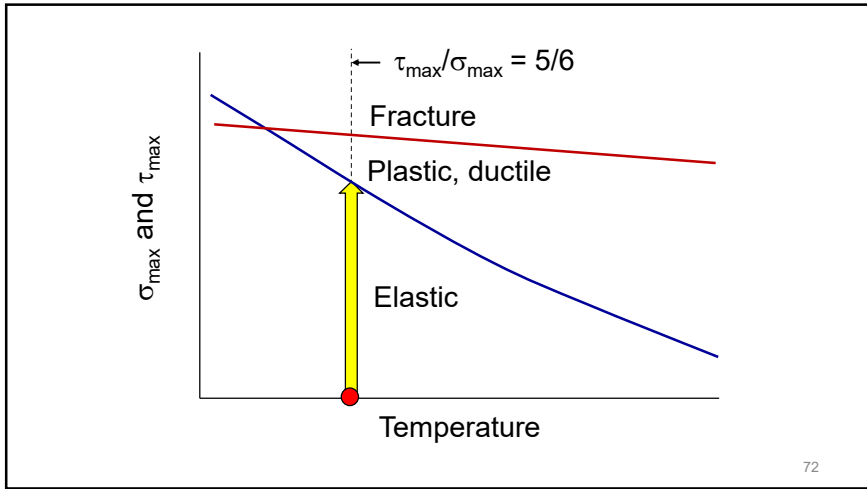
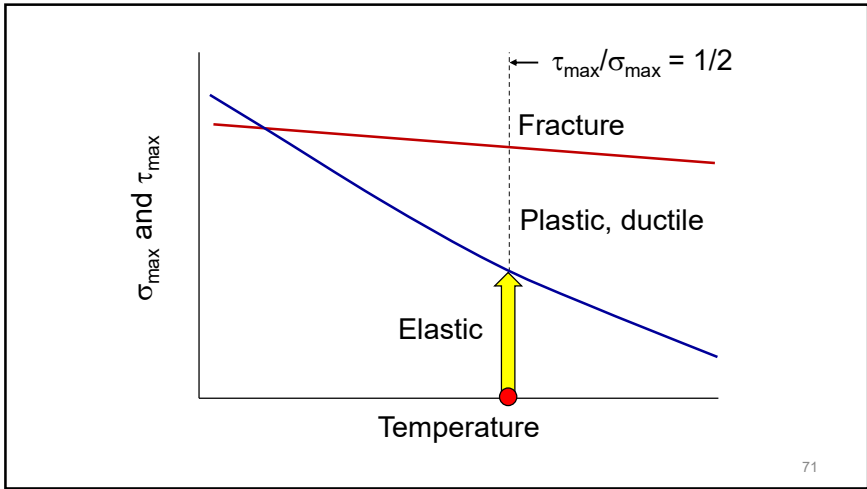
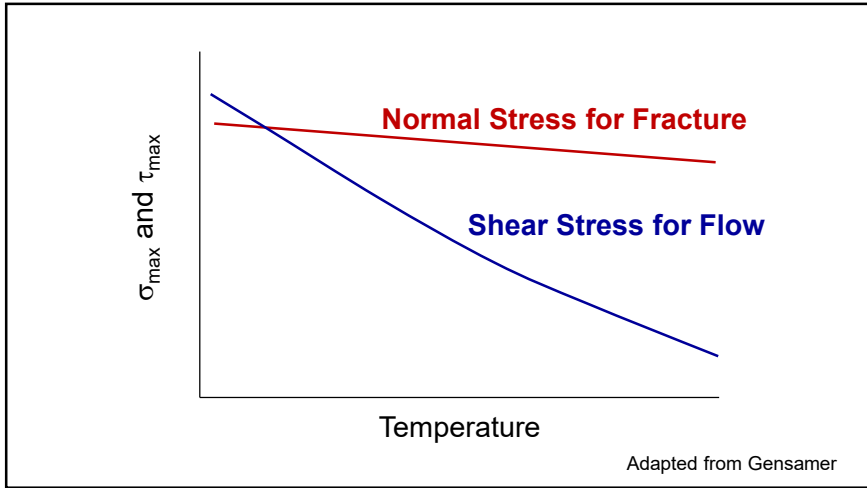
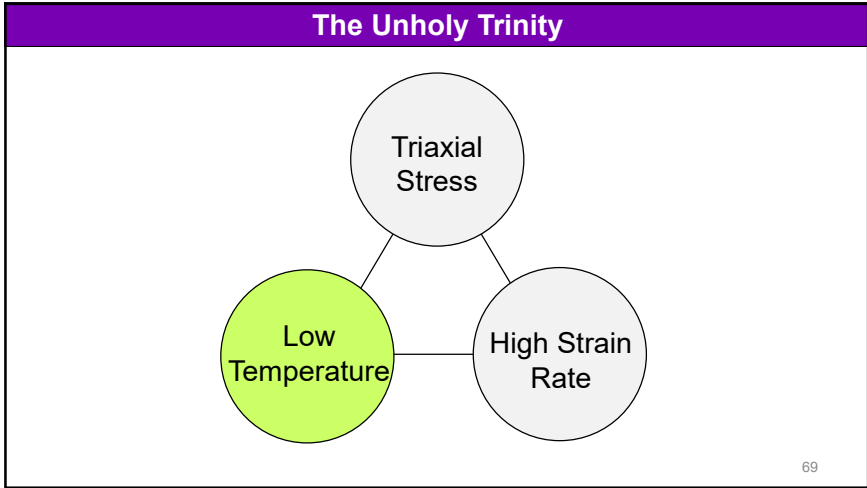

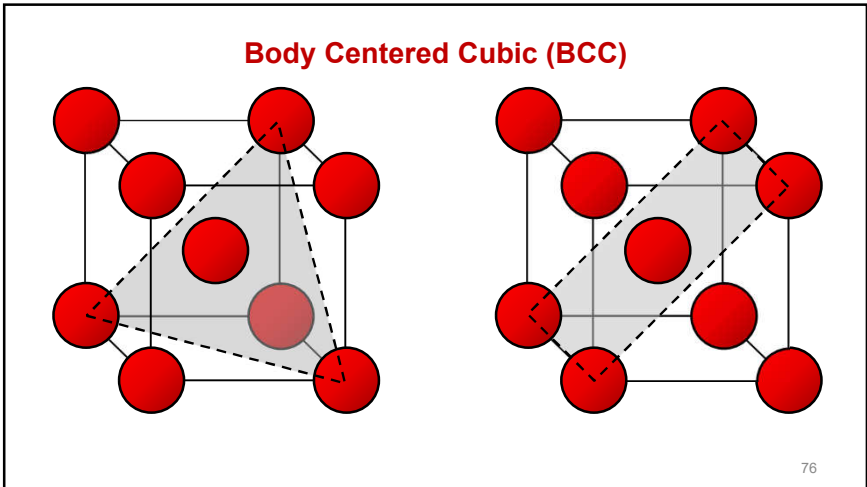
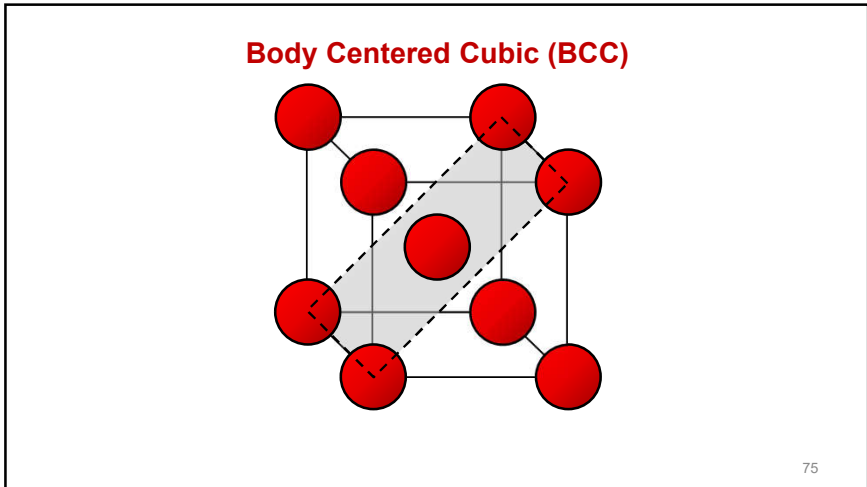
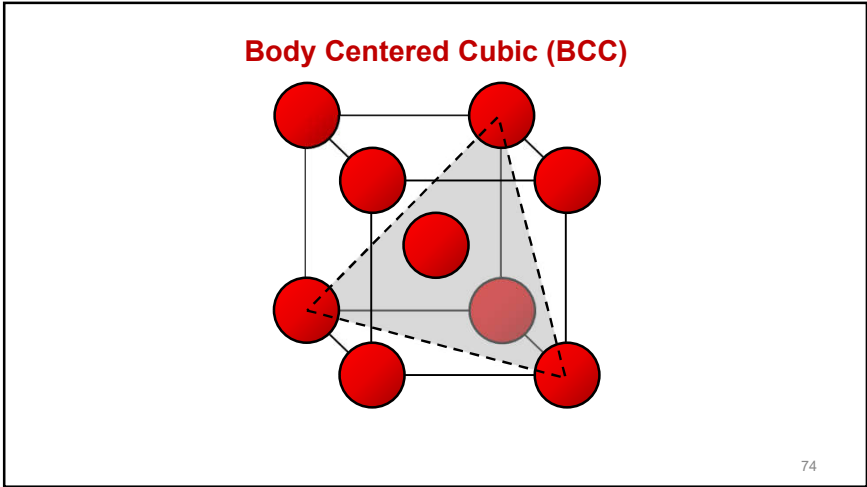
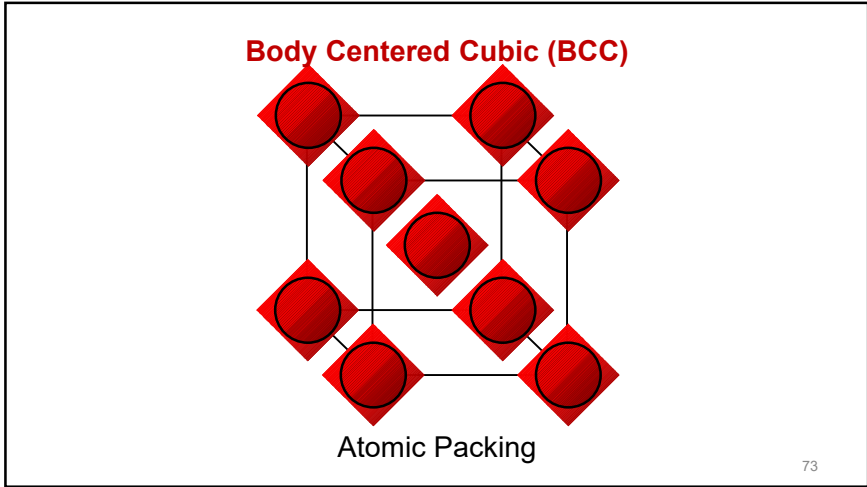

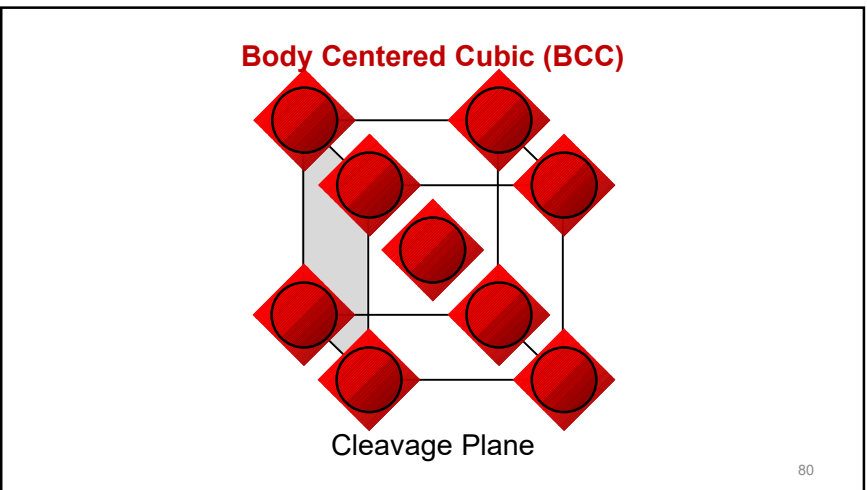
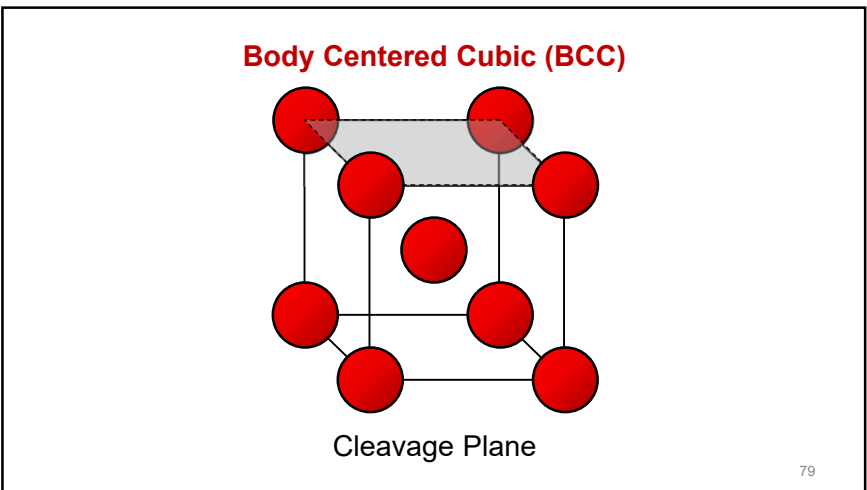
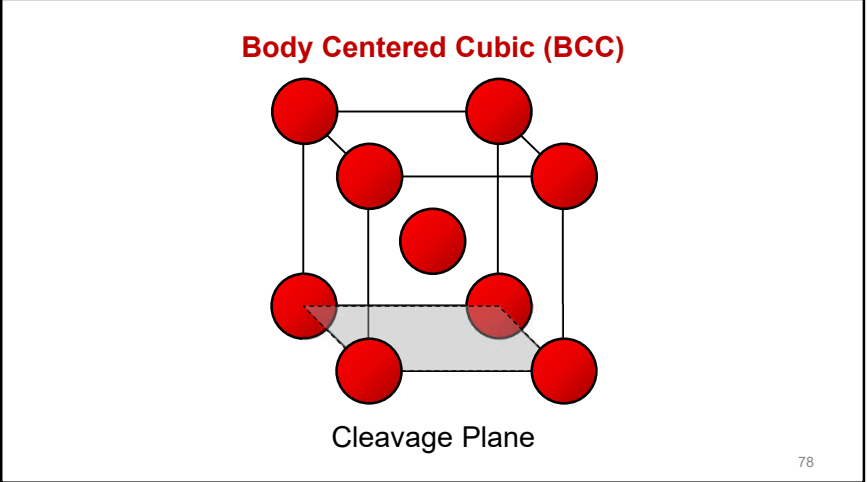
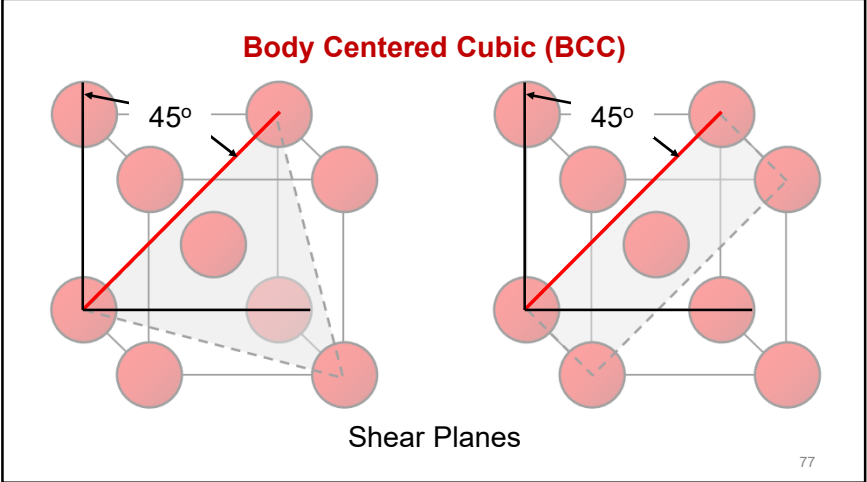

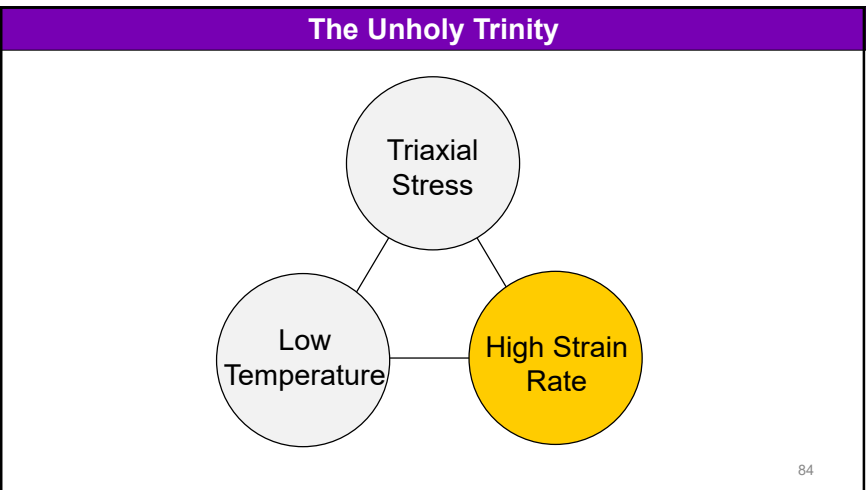
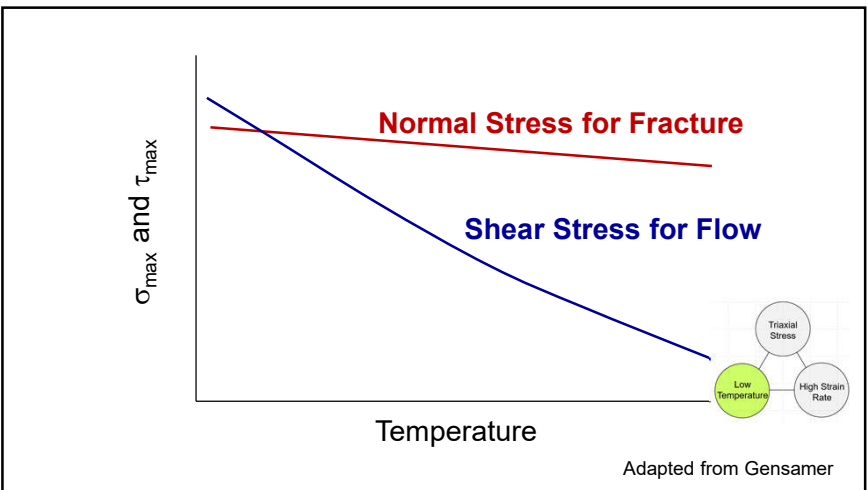
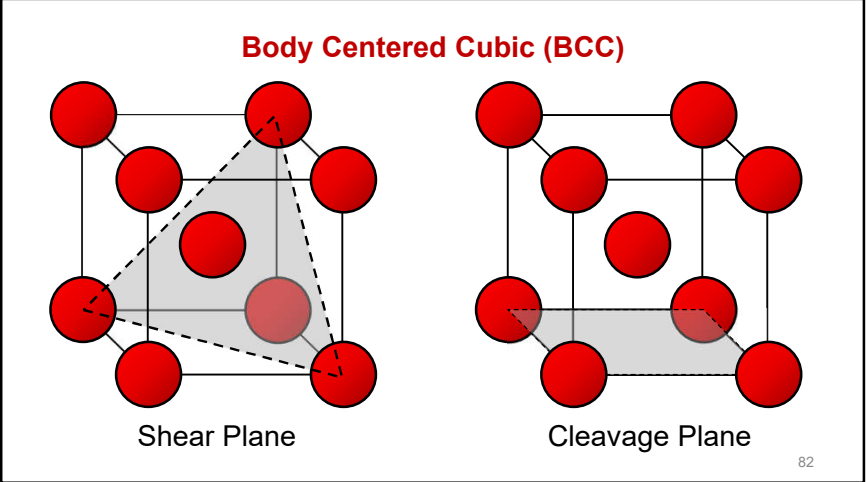
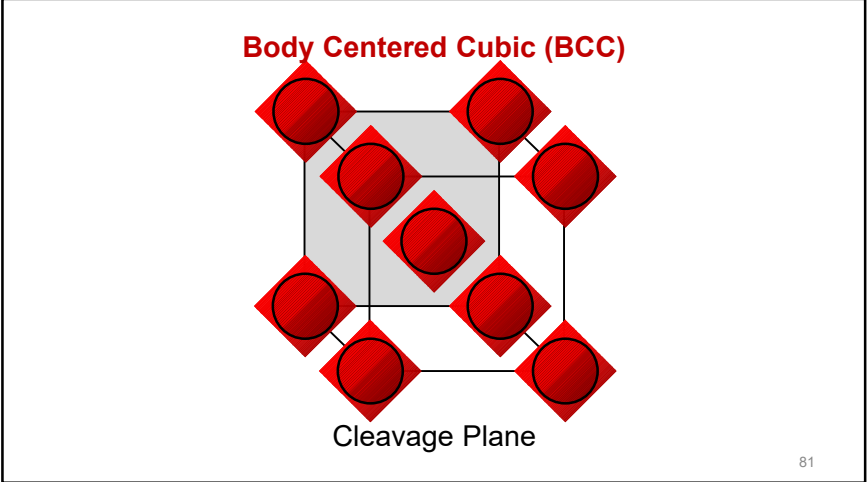

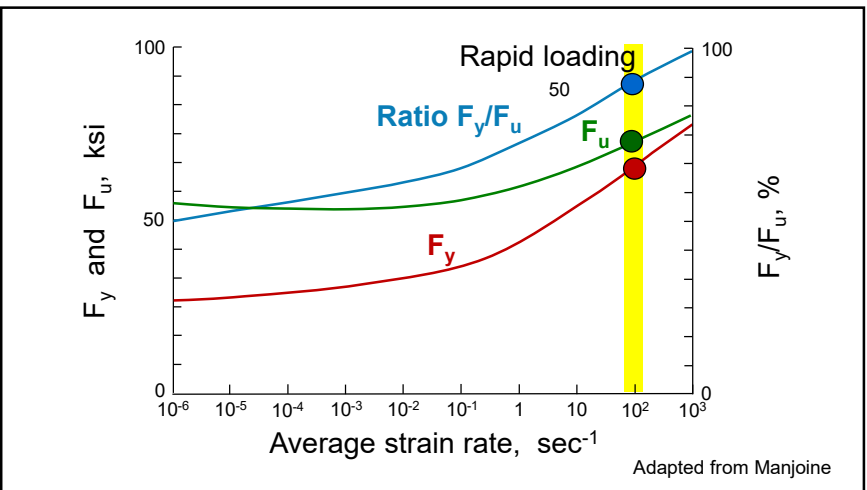
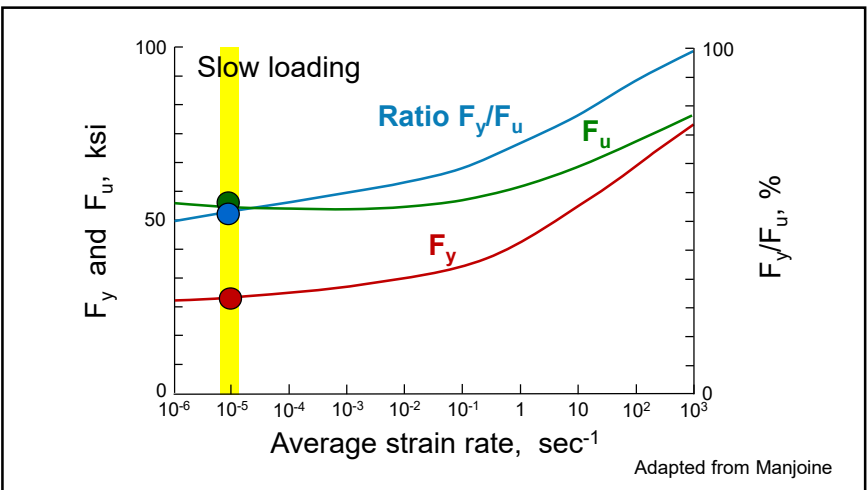
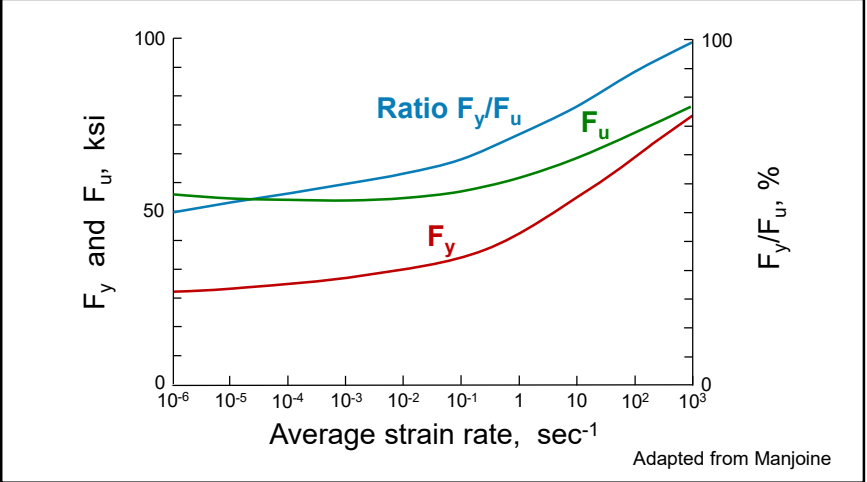
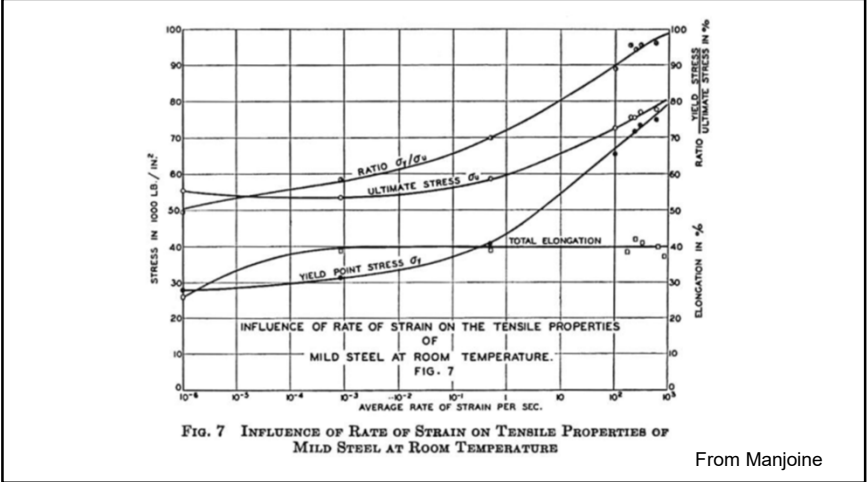

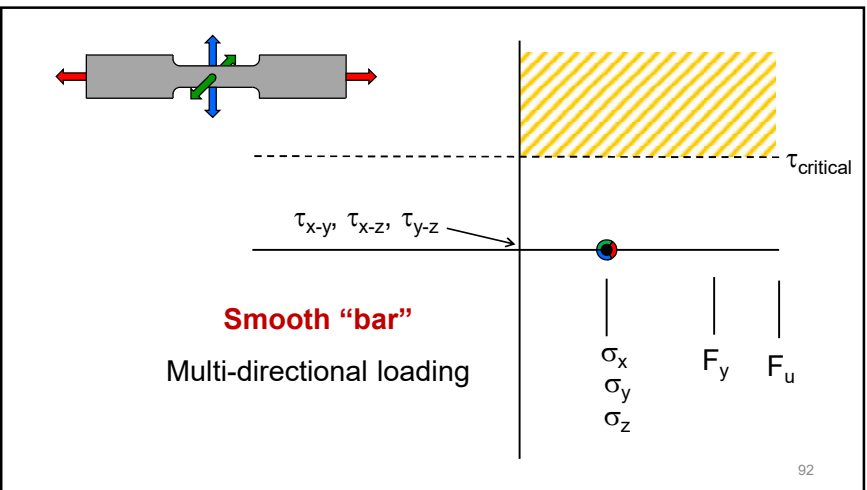
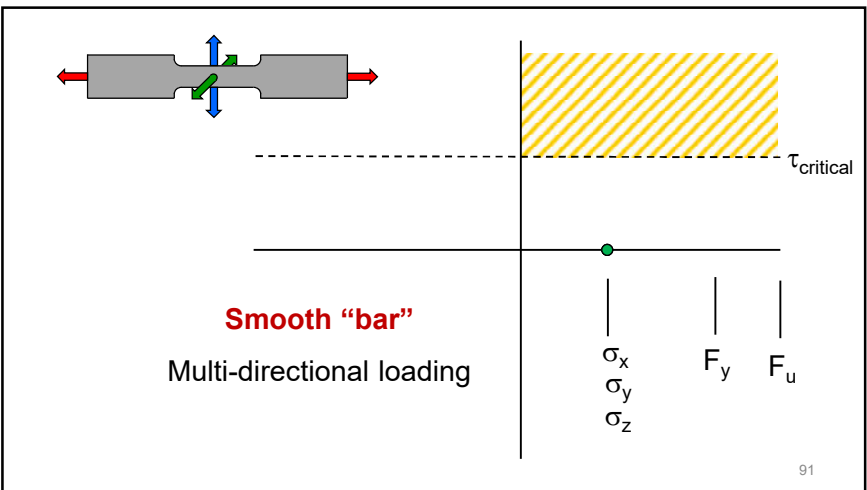
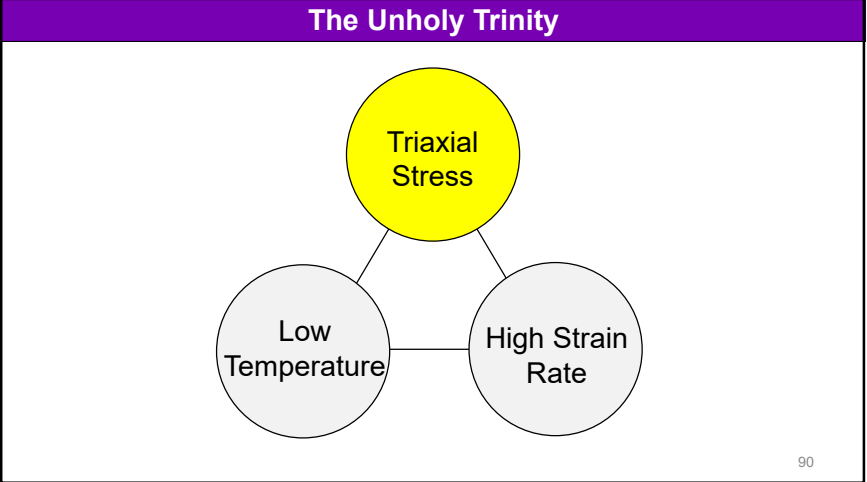
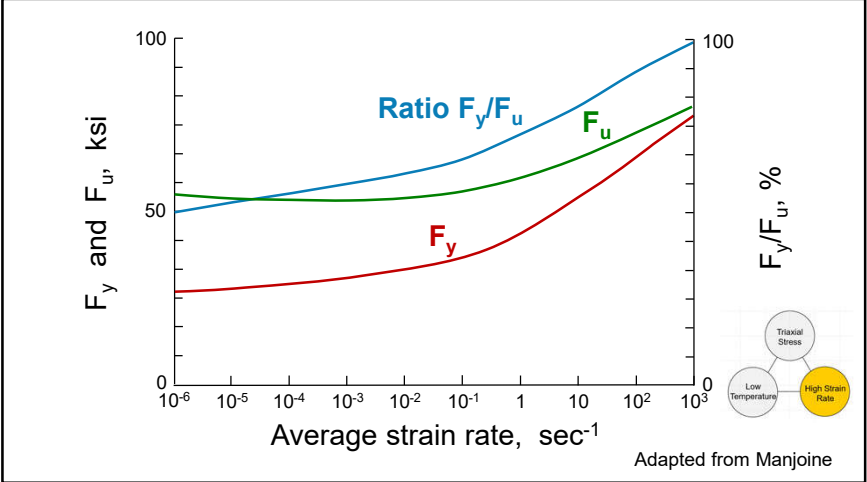

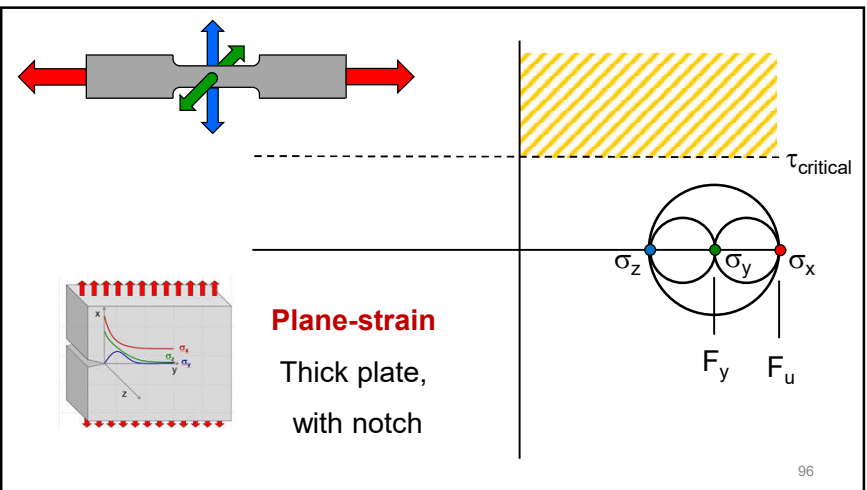
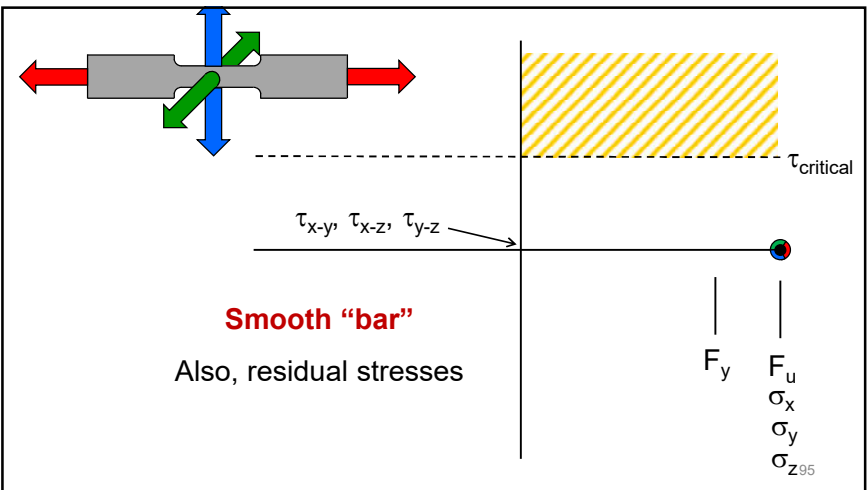
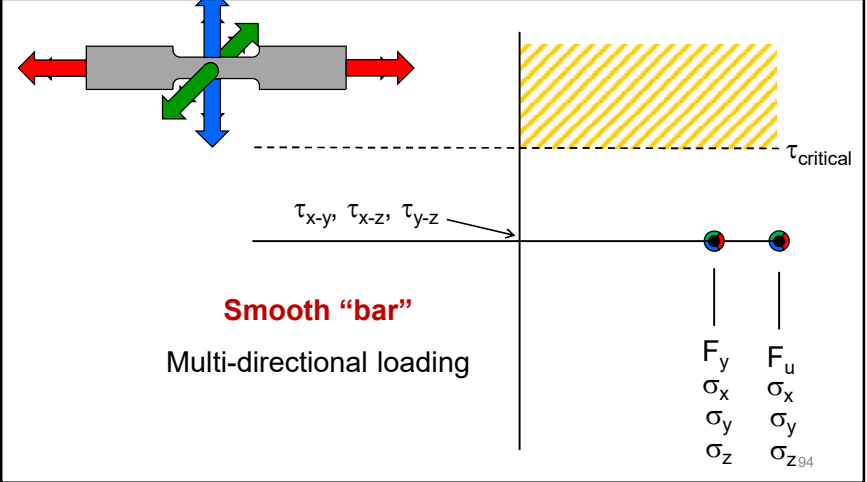
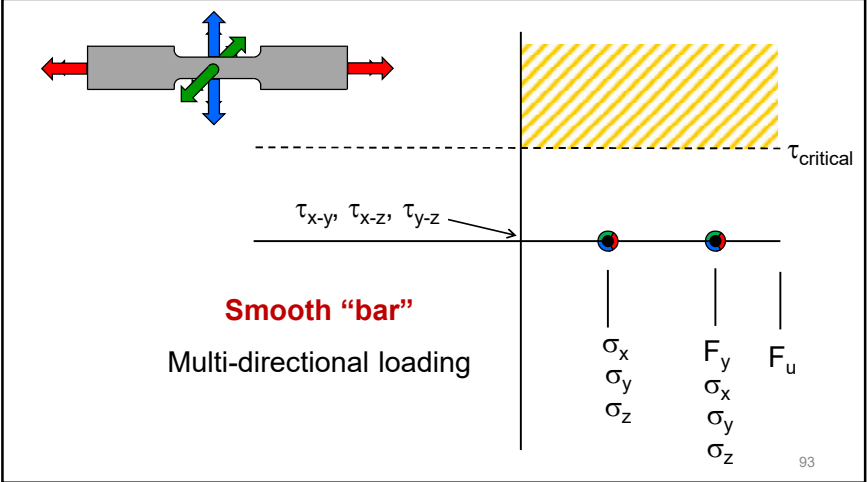

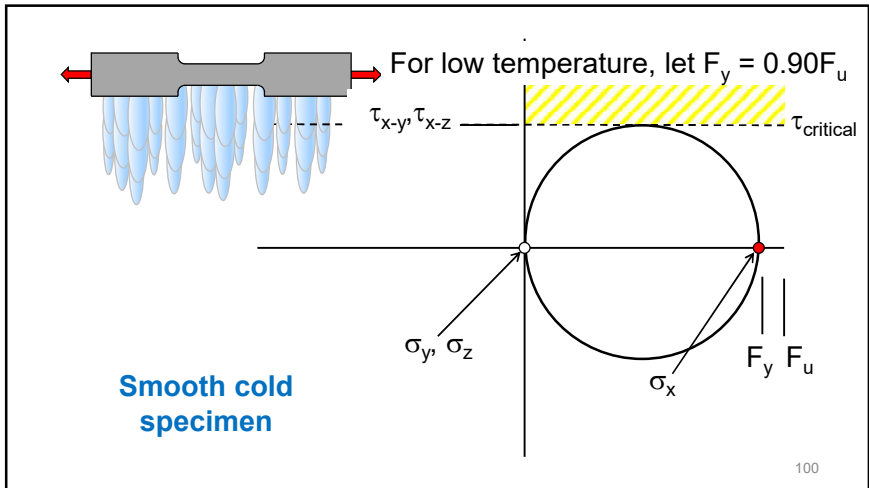
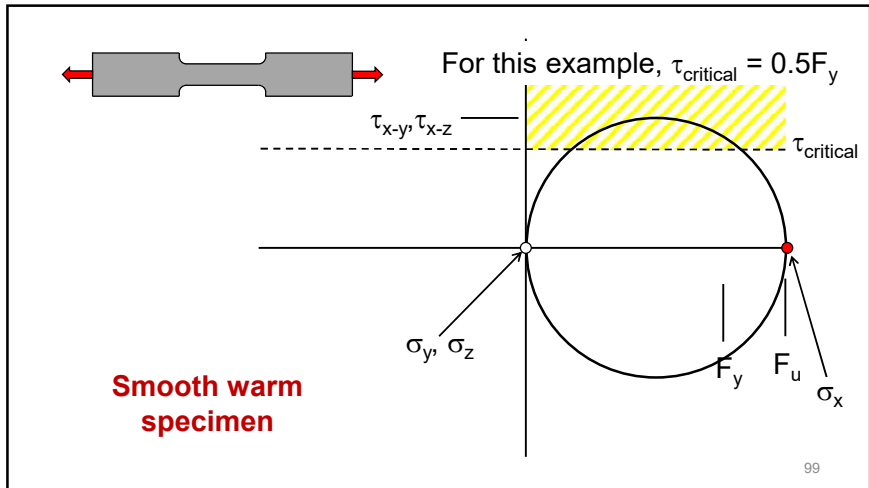
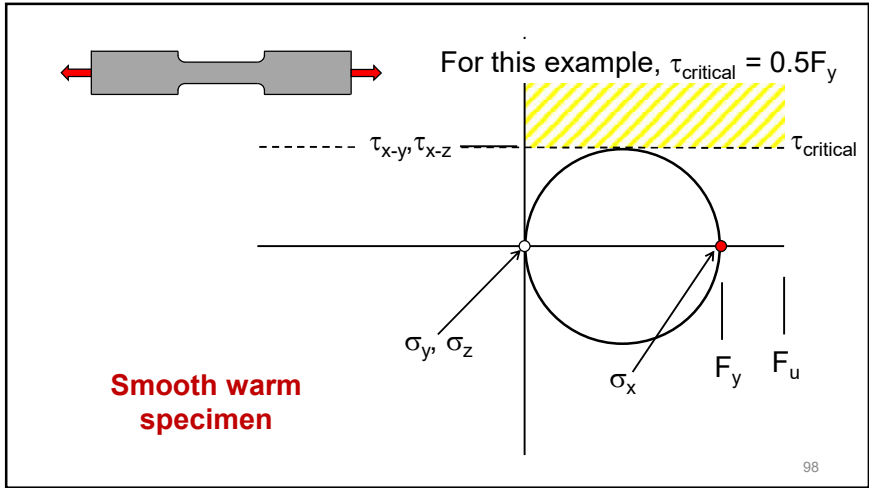
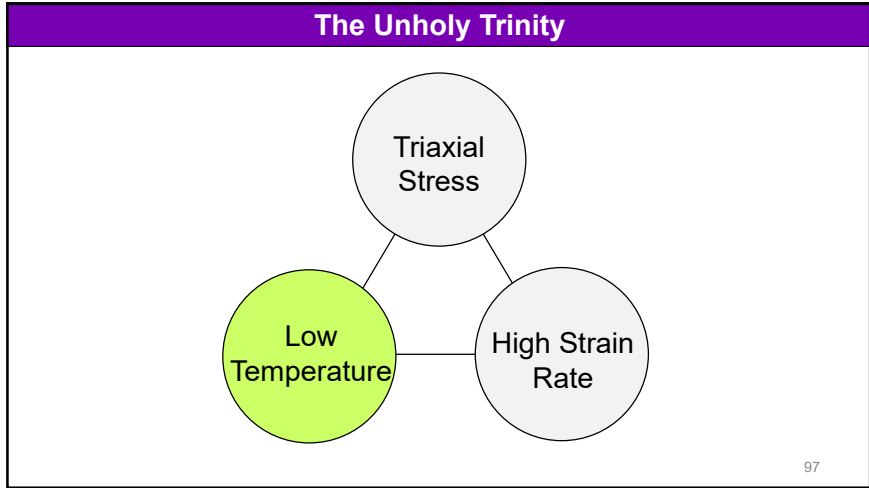

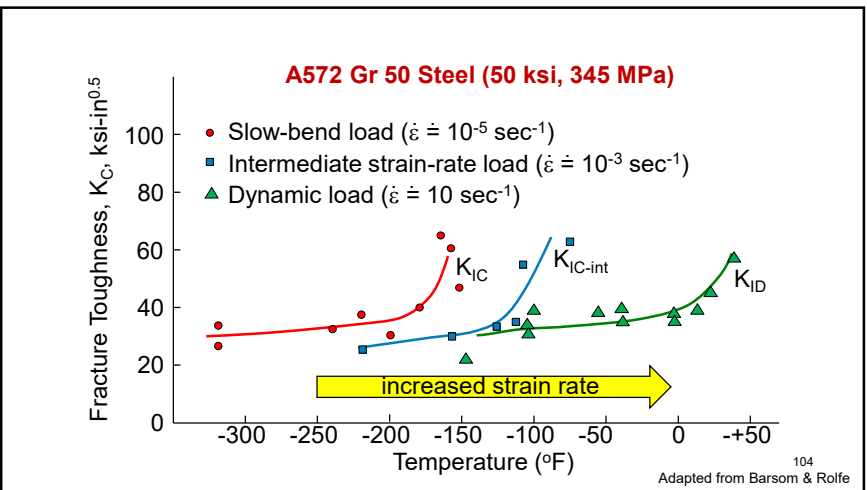
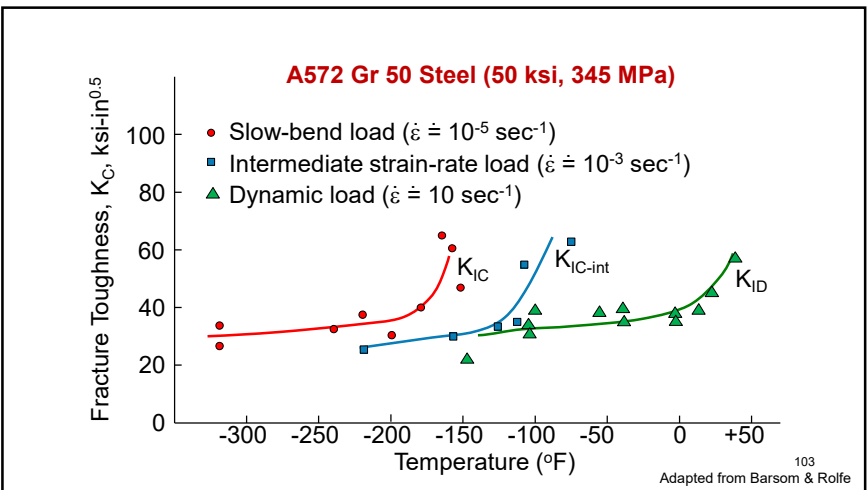
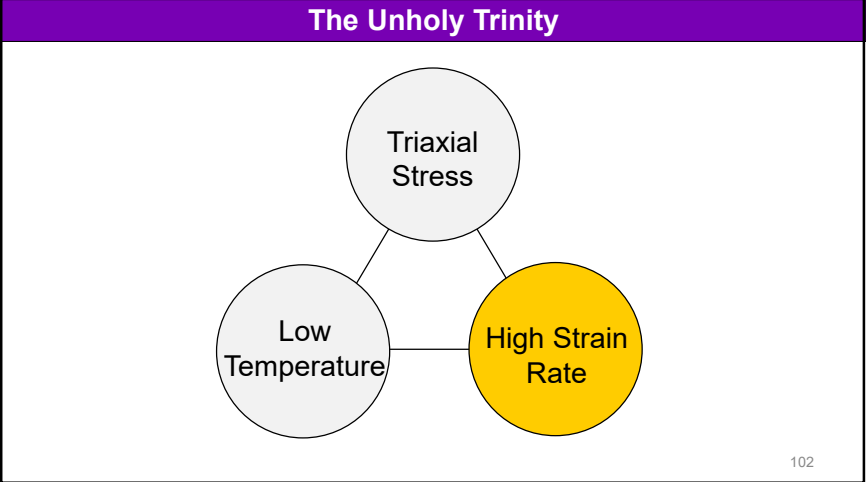
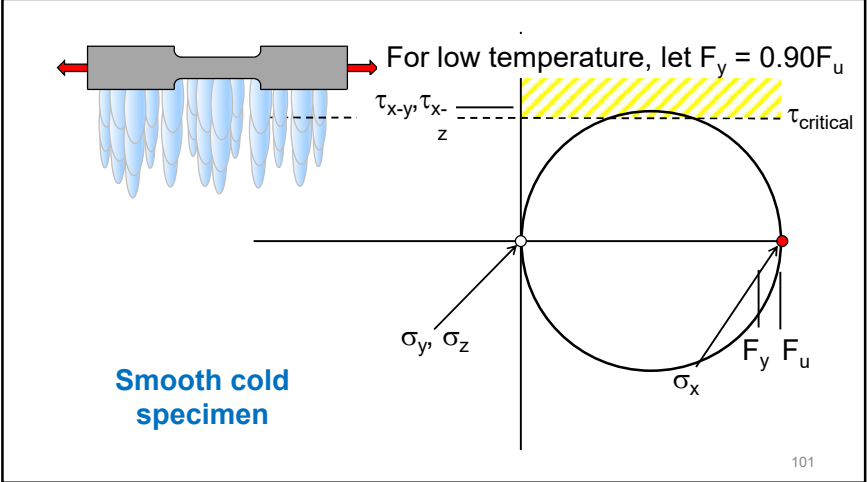

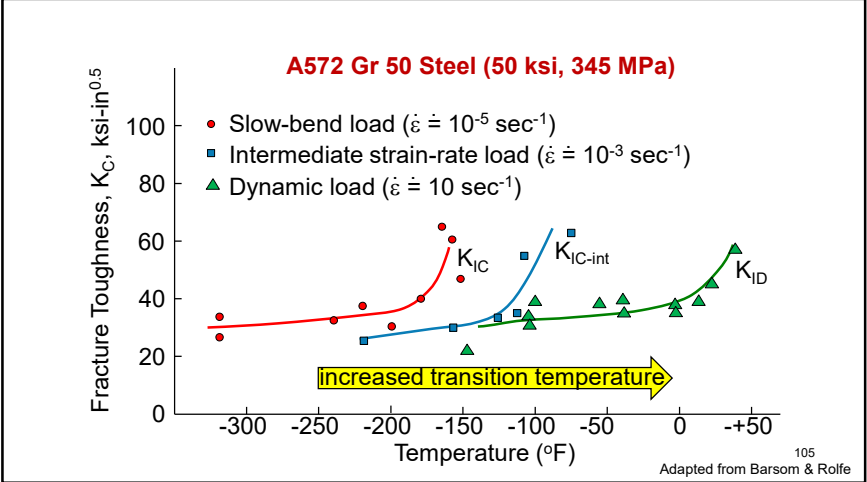

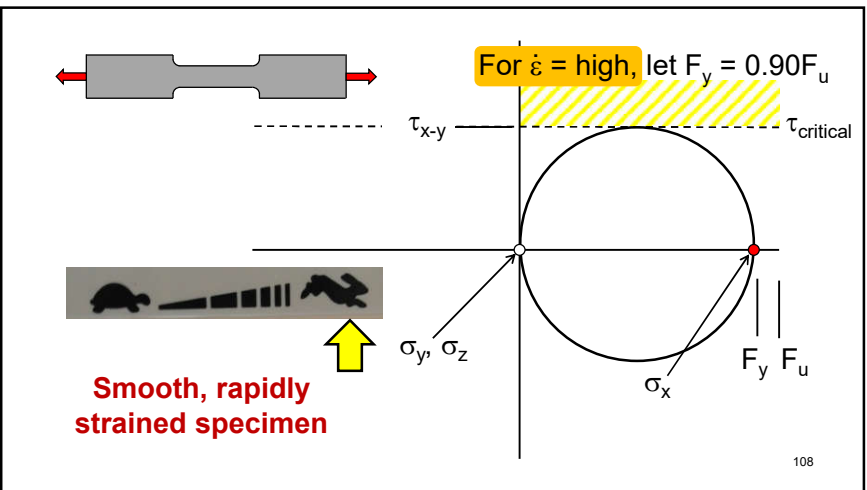
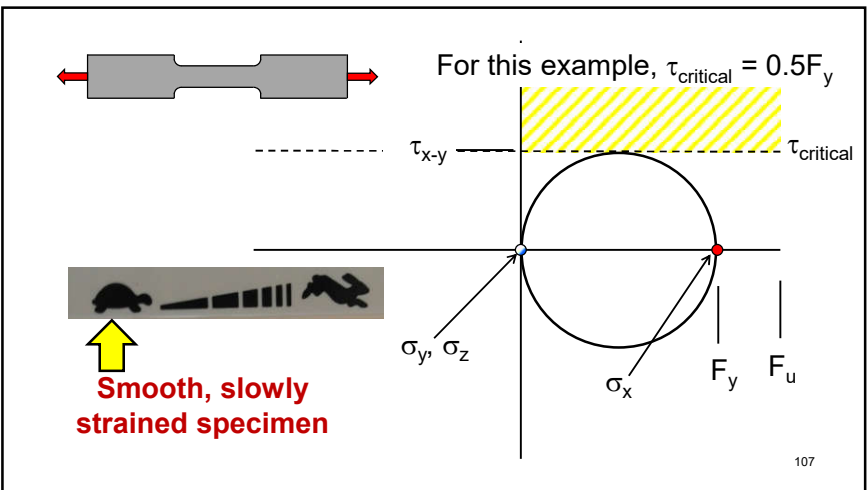

Dieter: MECHANICAL METALLURGY

The changes produced by the introduction of a notch have important consequences in the fracture process. For example, the presence of a notch will increase appreciably the ductile/brittle transition temperature of a steel.

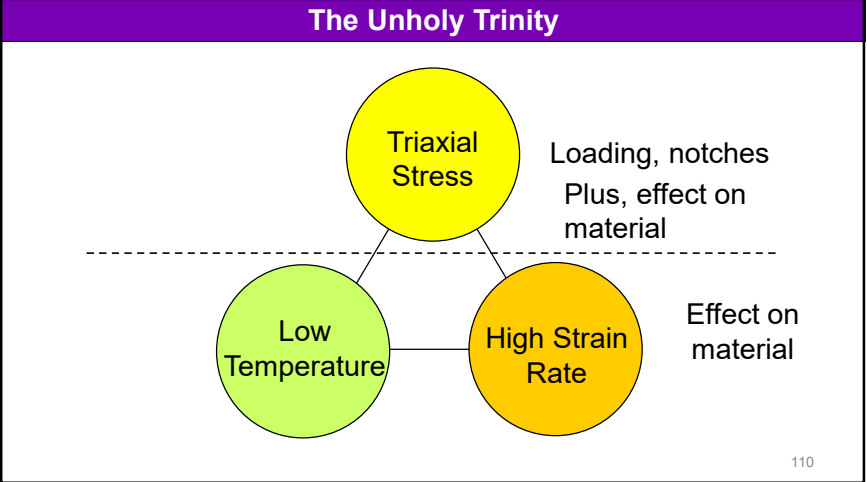
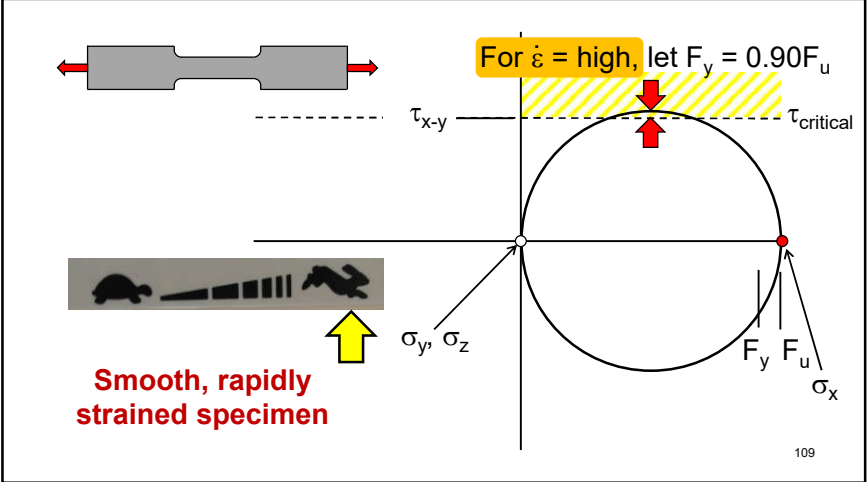



- Brittle Fracture: Another View
Outline**
- Definition of brittle fracture
 - Significance of brittle fracture
 - Factors affecting brittle fracture
 - ➔ • Case studies involving brittle fracture
 - Designing to prevent brittle fracture
- 
- Smarter.
Stronger.
Steel.

- Brittle Fracture: Another View
Outline**
- Case studies involving brittle fracture
 - ➔ • Case 1: Liberty ships
 - Case 2: Silver bridge
 - Case 3: Ingram barge
 - Case 4: Hoan bridge
- 
- Smarter.
Stronger.
Steel.



113

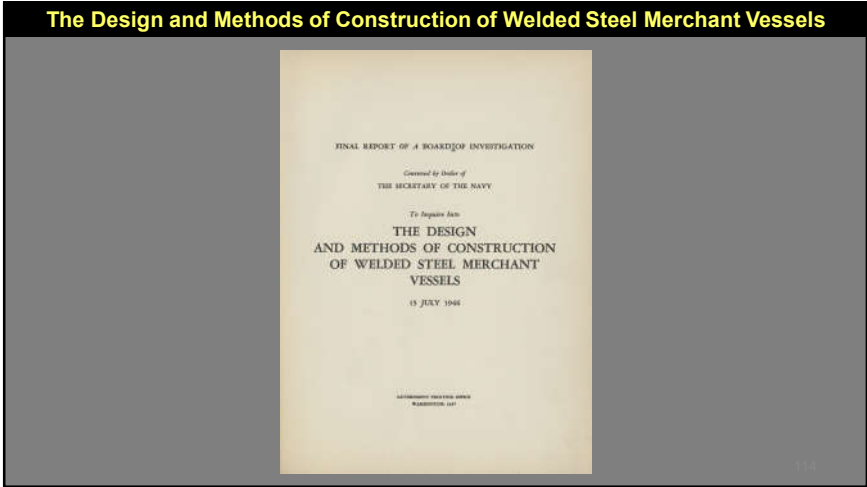

114

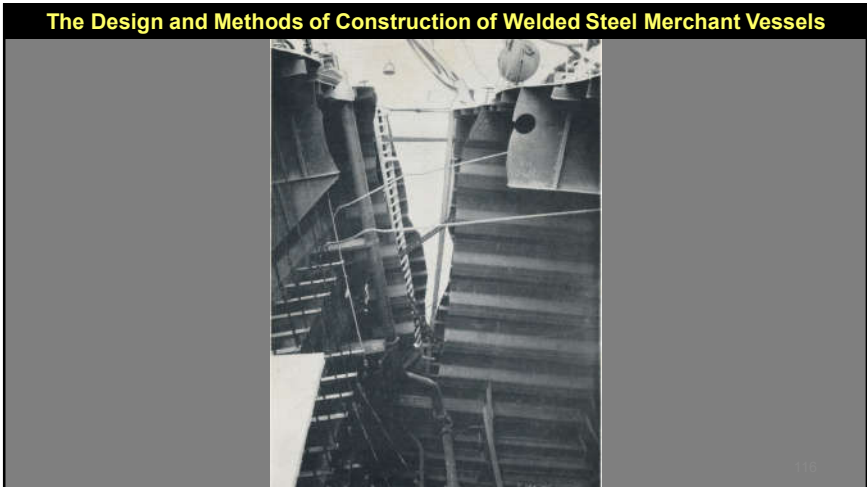
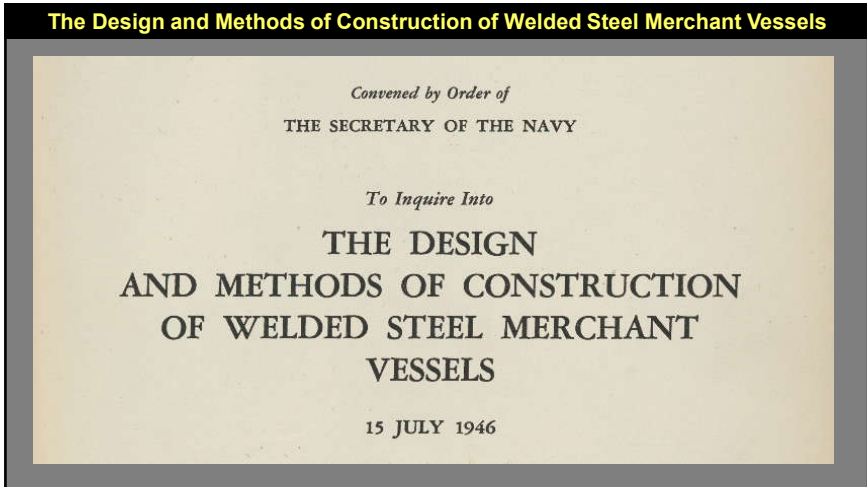

115

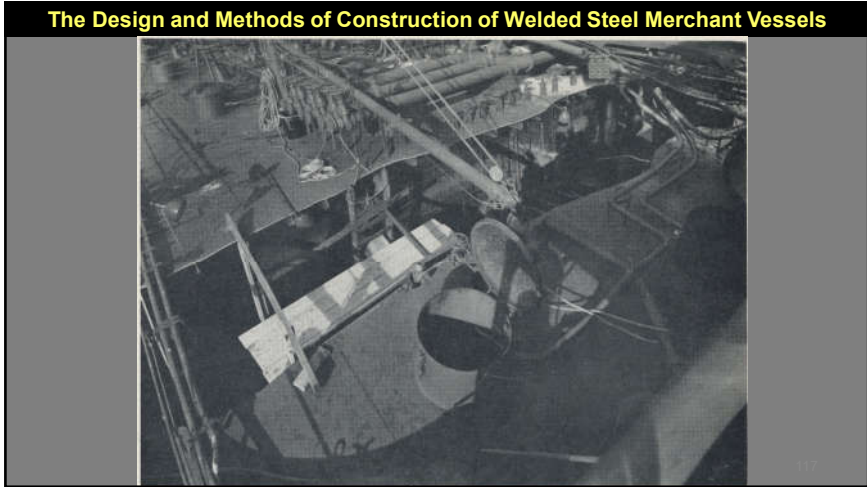

The Design and Methods of Construction of Welded Steel Merchant Vessels

Early in the war, welded merchant vessels experienced difficulties in the form of fractures which could not be explained. The fractures, in many cases, manifested themselves with explosive suddenness and exhibited a quality of brittleness which was not ordinarily associated with the behavior of a normally ductile materials such as ship steel.

118

The Design and Methods of Construction of Welded Steel Merchant Vessels

Total number of ships	4,696
Total number of these ships reporting no casualties	3,724
Total number of these ships which sustained casualties	970
Total number of casualties	1,442
Total number of fractures	4,720
Total cases of serious casualties (Class 1)	127
Total ships sustaining a complete fracture of strength deck	24
Total ships sustaining a complete fracture of the bottom	1

119

The Design and Methods of Construction of Welded Steel Merchant Vessels

Eight vessels have been lost, as follows:

Name	Date	Remarks
Thomas Hooker	5 Mar 1943	Abandoned
J.L.M. Curry	7 Mar 1943	Abandoned
John P. Gaines	24 Nov 1943	Broke in two, abandoned
Joseph Smith	9 Jan 1944	Abandoned
Samuel Dexter	21 Jan 1944	Abandoned
Joel R. Poinsett	4 Mar 1944	Broke in two; stern portion salvaged
Sackett's Harbor	1 Mar 1946	Broke in two; stern portion salvaged
Fort Sumter	10 May 1946	Broke in two; both portions scuttled

120

The Design and Methods of Construction of Welded Steel Merchant Vessels

Four other ships broke in two but were not lost	
Schenectady	15 Jan 1943
Esso Manhattan	29 Mar 1943
Valeri Chkalov	11 Dec 1943
Donbass III	17 Feb 1946

121

The Design and Methods of Construction of Welded Steel Merchant Vessels

122

The Design and Methods of Construction of Welded Steel Merchant Vessels

REPORT OF STRUCTURAL FAILURE OF INSPECTED VESSEL
 UNITED STATES COAST GUARD
 8000-1717

This report includes all available information up to: **1 Apr., 1944**

DESCRIPTION OF VESSEL			
NAME SCHENECTADY	OFFICIAL NO. 242620	TYPE (Dry Cargo, Passenger, etc.) Tank Vessel	U.S. DESIGN TC-SR-A1
BUILDER Kaiser Co., Inc., Portland, Oregon	BUILDER'S HULL NO. 1	DATE COMPLETED 31 Dec., '43	
OWNER War Shipping Administration	OPERATOR Deoonhill Shipping Company		

EXTENT OF WELDING

<input checked="" type="checkbox"/> Yes	SIZE SHELL SEAMS	<input checked="" type="checkbox"/> Yes	NO INNER BOTTOM	<input checked="" type="checkbox"/> Yes	BECK SEAMS
<input checked="" type="checkbox"/> Yes	SIZE SHELL BUTTS	<input checked="" type="checkbox"/> Yes	BOTTOM SEAMS	<input type="checkbox"/> -	INNER BOTTOM SEAMS
<input checked="" type="checkbox"/> Yes	FRAMES TO SIDE SHELL	<input checked="" type="checkbox"/> Yes	BOTTOM BUTTS	<input type="checkbox"/> -	INNER BOTTOM BUTTS
<input checked="" type="checkbox"/> Yes	BULKHEADS	<input checked="" type="checkbox"/> Yes	FLOORS TO SHELL	<input type="checkbox"/> -	FLOORS TO INNER BOTTOM
<input type="checkbox"/> No		<input type="checkbox"/> No		<input type="checkbox"/> No	
<input type="checkbox"/> No		<input type="checkbox"/> No		<input type="checkbox"/> No	
<input type="checkbox"/> No		<input type="checkbox"/> No		<input type="checkbox"/> No	
<input type="checkbox"/> No		<input type="checkbox"/> No		<input type="checkbox"/> No	

CIRCUMSTANCES SURROUNDING FAILURE
 (Attach all available details of ship's loading)

DATE OF FAILURE 16 Jan., 1943	TIME 2230 PWT	PLACE Tied up at fitting out pier, Swan Island
----------------------------------	------------------	---------------------------------------------------

123

The Design and Methods of Construction of Welded Steel Merchant Vessels

APPROXIMATE STARTING POINT

The fracture started at the juncture of the fashion plate at the aft starboard corner of the bridge superstructure and the sheer strake.

GENERAL HISTORY AND DESCRIPTION OF FAILURE, INCLUDING KNOWN CONTRIBUTORY FACTORS:

Without warning and with a report which was heard for at least a mile, the deck and sides of the vessel fractured just aft of the bridge superstructure. The fracture extended almost instantaneously to the turn of the bilge port and starboard. The deck side shell, longitudinal bulkheads and bottom girders fractured. Only the bottom plating held. The vessel jack-knifed and the center portion rose so that no water entered the hull. The bow and stern settled into the silt of the river bottom. Sounding taken around the vessel eliminated the alleged possibility of the vessel having grounded amidships to a drop in water level. Bending moment in still water = 184,000 Ft. x Tons Hog amidships. Stress in crown of deck = 9900 Lbs./in.² Tension.

CLASSIFICATION OF FAILURE
Broke in two

DISPOSITION OF VESSEL
 (Repaired, lost, etc.)

Vessel repaired and put in service.

701292-47-5 Figure 14. 124

The Design and Methods of Construction of Welded Steel Merchant Vessels

Without warning and with a report which was heard for at least a mile, the deck, and sides of the vessel fractured just aft of the bridge superstructure.

the Bilge port and starboard. The deck side shell, longitudinal bulkheads and bottom girders fractured. Only the bottom plating held. The vessel

Stress in crown of deck = 9900 Lbs./in. Tension.

Vessel repaired and put in service.

Vessel repaired and put in service.

Figure 14.

125

The Design and Methods of Construction of Welded Steel Merchant Vessels

I. Conclusions

The Board concludes that:

(a) The fractures in welded ships were caused by notches and by steel which was notch sensitive at operating temperatures. When an adverse combination of these occur the ship may be unable to resist the bending moments of normal service.

126

Barsom/Rolfe: FRACTURE AND FATIGUE CONTROL IN STRUCTURES

The majority of the fractures in the Liberty ships started at square hatch corners or square cutouts at the top of the sheer strake. Design changes involved rounding and strengthening of the hatch corners, removing square cutouts in the sheer strake, and adding riveted crack arresters in various locations led to immediate reductions in the incidence of failures.

127

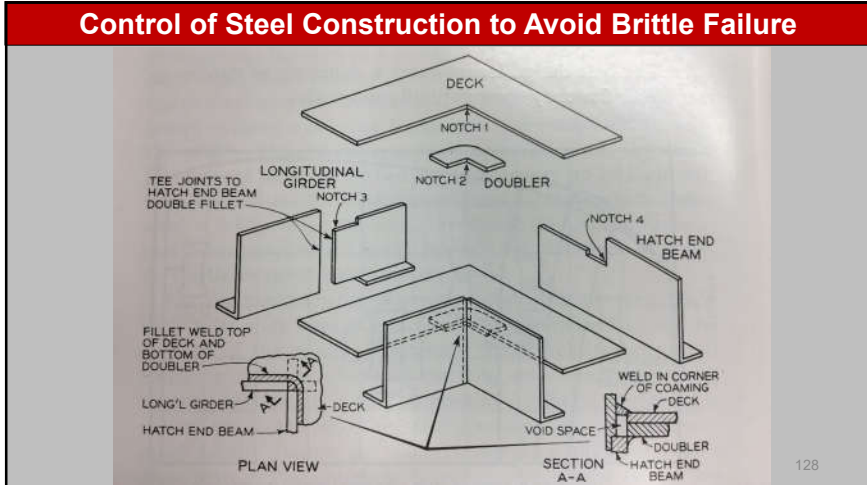

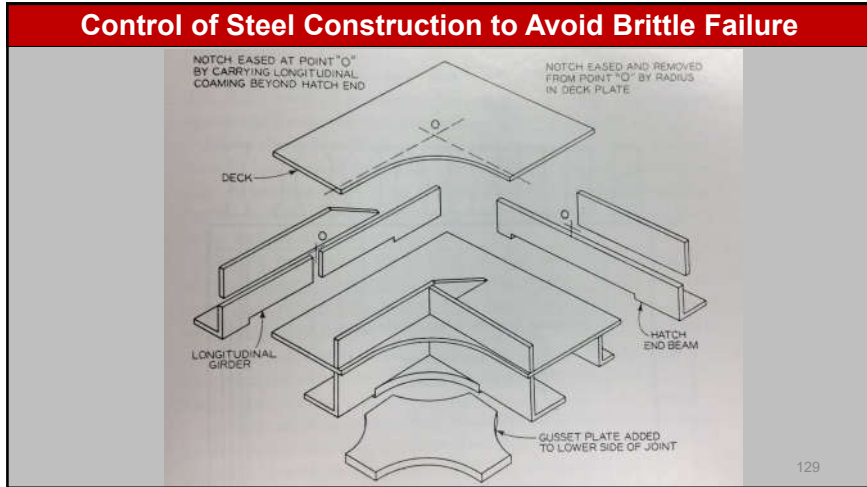

Lehigh University
Lehigh Preserve

Fritz Laboratory Reports Civil and Environmental Engineering

1980

Fracture control considerations for steel bridges,
March 1980

J.M. Barsom
J.W. Fisher
K.H. Frank
G.R. Irwin

Fracture control considerations for bridge steels

Although steel quality later was found to be an important factor in these failures, **the immediate solution to the problem was achieved by design changes and better quality fabrication.** It was not until the 1950's that changes in material toughness were made.

- Brittle Fracture: Another View
Outline**
- **Case studies involving brittle fracture**
 - **Case 1: Liberty ships**
 - ➔ • **Case 2: Silver bridge**
 - **Case 3: Ingram barge**
 - **Case 4: Hoan bridge**



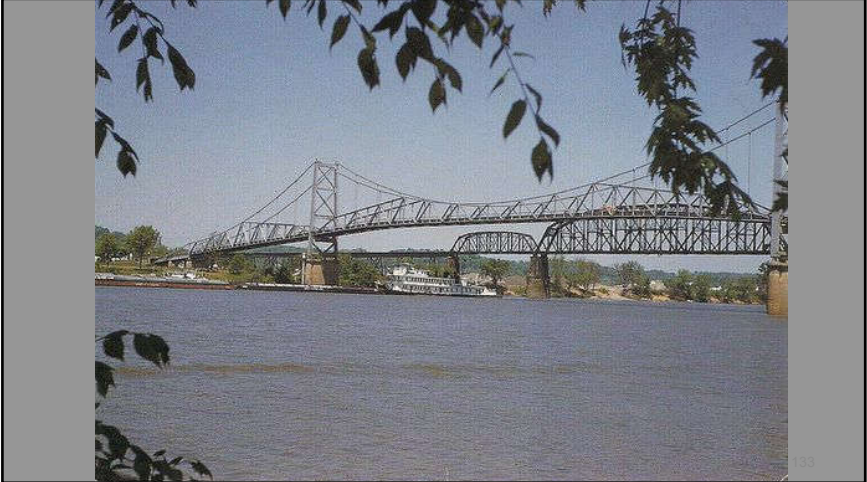

Silver Bridge Summary

- Opened to traffic May 1928
- Collapsed December 1967
- Eyebar suspension bridge
- 30 °F at time of collapse

135

- Total length: 1756 feet
- Main span: 700 feet
- River width: 1240 feet

136

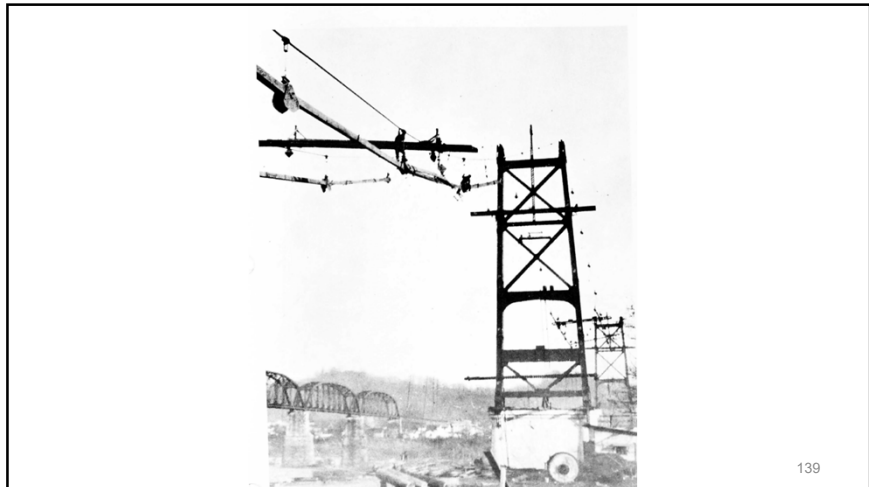
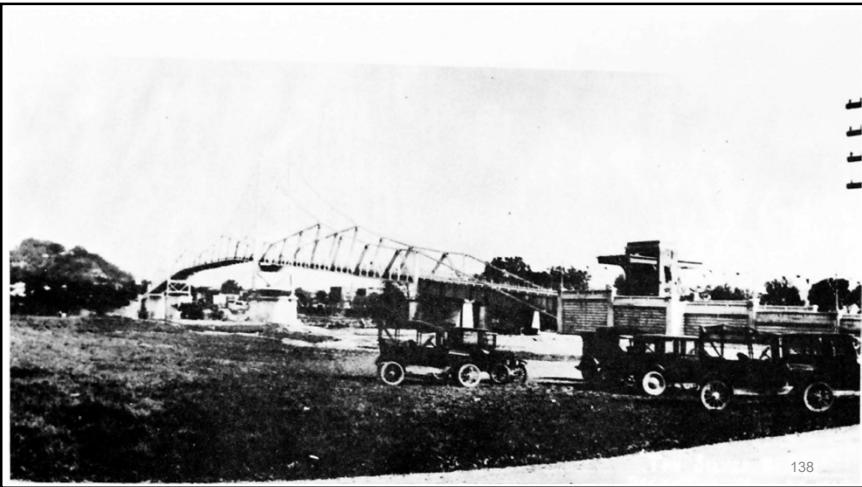
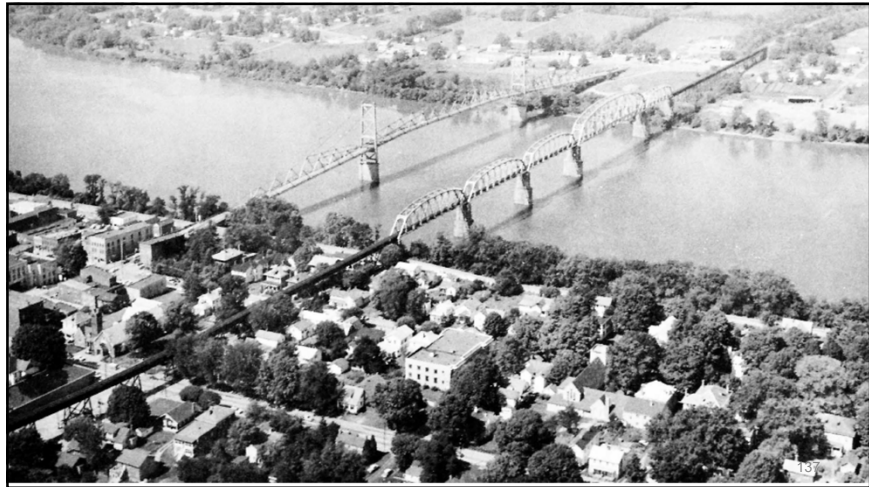

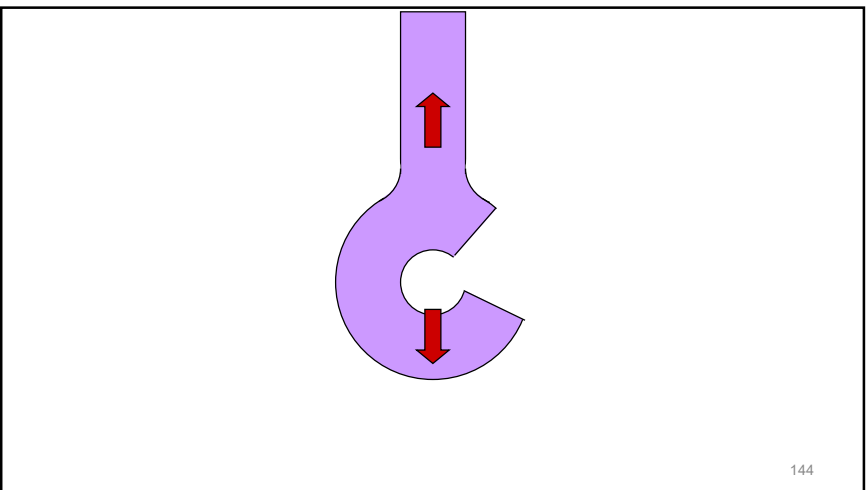
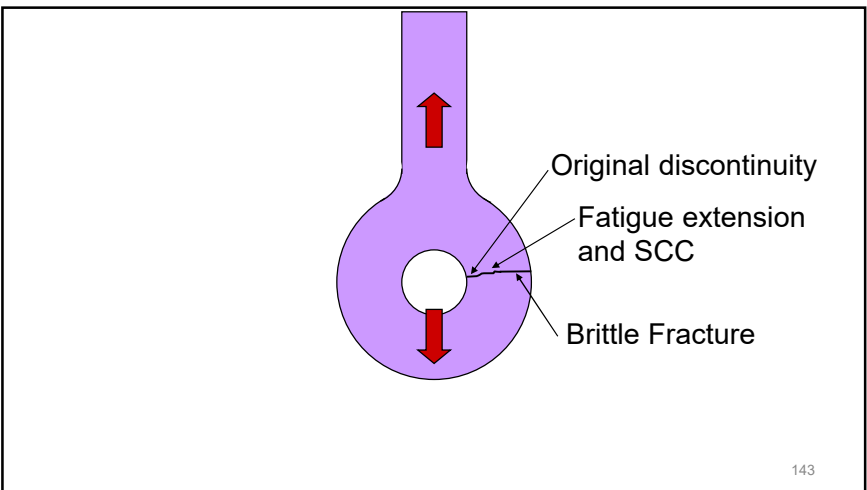
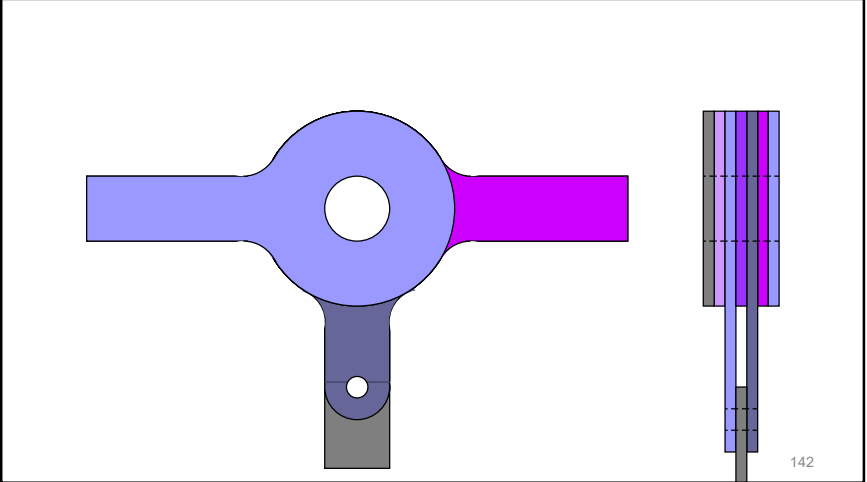
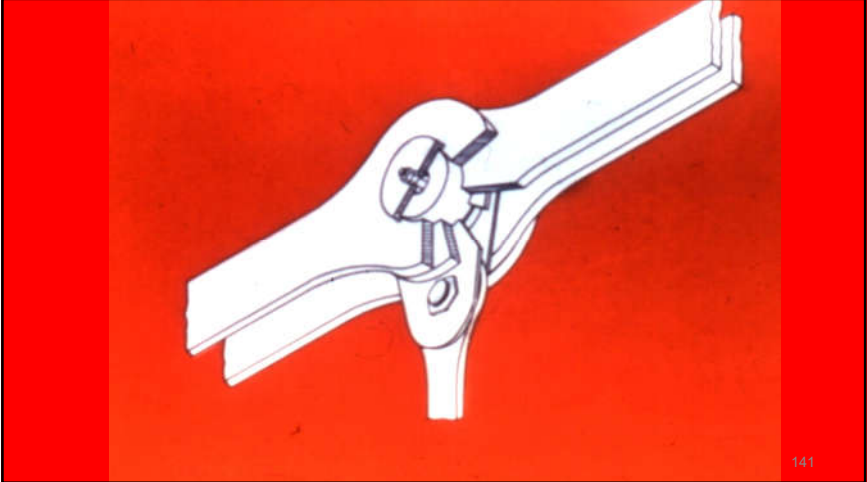

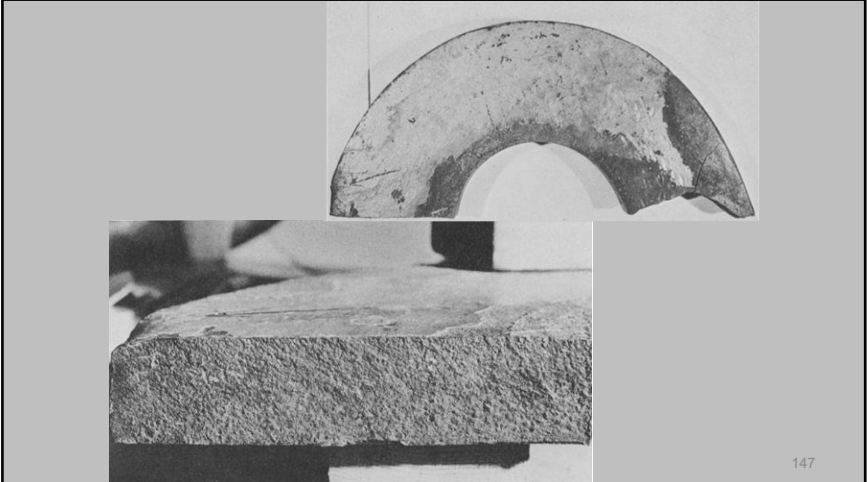
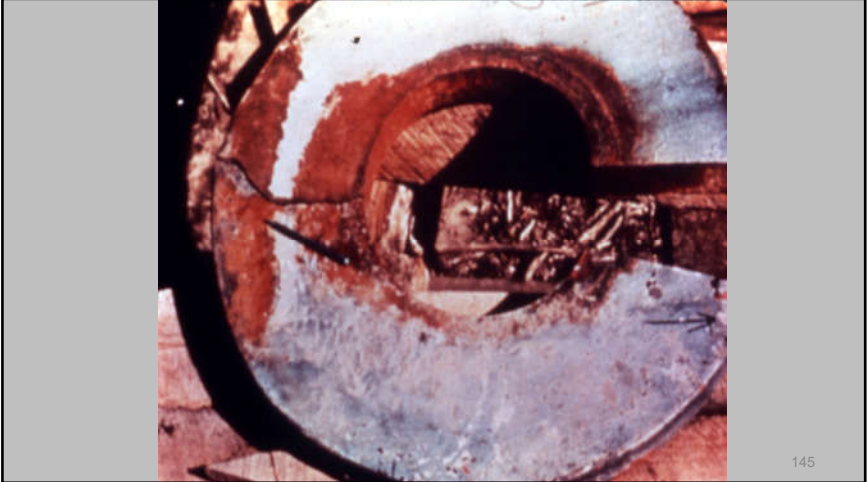



Gensamer: STRENGTH OF METALS UNDER COMBINED STRESS

It is well known that a metal **may be ductile under one set of conditions and brittle under another.**

Ductility and brittleness, then are properties that must be considered as referring to some particular set of testing or service conditions.

150

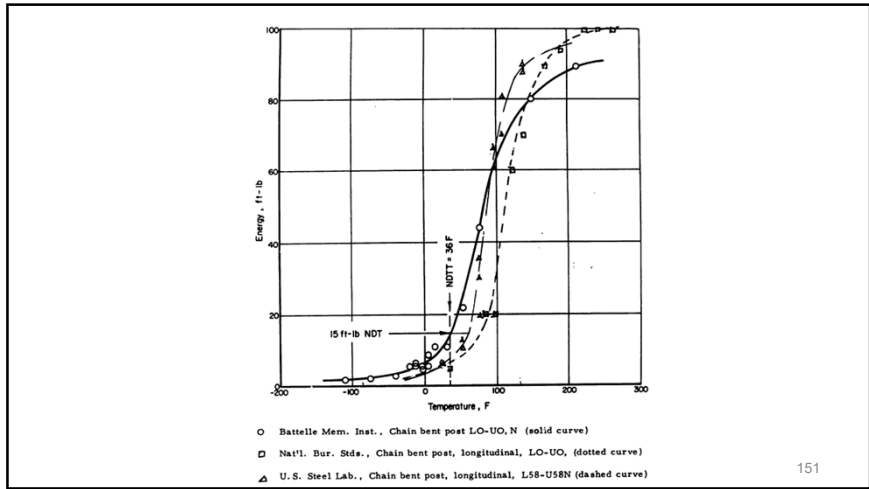

HIGHWAY ACCIDENT REPORT
 National Transportation Safety Board

152

EVENTS BEFORE BRIDGE COLLAPSE

At about 4:35 p. m. on December 15, 1967, two witnesses saw objects on the roadway of the bridge just east of the Ohio tower. The first person, who was a machinist, identified the object he saw as a large nut that he believed had the shank of a bolt in the nut in a position near the curb of the eastbound lane. He identified the nut as similar to the 1-1/4-inch nuts used on the bridge to secure the pin retainers on the eyebar joints. The other witness stated she saw an object resembling an automobile hubcap on the north side of the roadway. She was unable to state the object was a pin retainer. Both witnesses were in moving automobiles and did not stop. Their observations were therefore of very brief duration.

EVENTS BEFORE BRIDGE COLLAPSE

At about 4:35 p. m. on December 15, 1967, two witnesses saw objects on the roadway of the bridge just east of the Ohio tower.

The first person, who was a machinist, identified the object he saw as a large nut...similar to the 1-1/4-inch nuts used on the bridge to secure the pin retainers on the eyebar joints.

roadway. She was unable to state the object was a pin retainer. Both witnesses were in moving automobiles and did not stop. Their observations were therefore of very brief duration.

EVENTS BEFORE BRIDGE COLLAPSE

At about 4:35 p. m. on December 15, 1967, two witnesses saw objects on the roadway of the bridge just east of the Ohio tower.

The other witness stated she saw an object resembling an automobile hubcap on the north side of the roadway. She was unable to state the object was a pin retainer.

roadway. She was unable to state the object was a pin retainer. Both witnesses were in moving automobiles and did not stop. Their observations were therefore of very brief duration.

J. A. Bennett and Harold Mindlin²

Metallurgical Aspects of the Failure of the Point Pleasant Bridge

REFERENCE: Bennett, J. A. and Mindlin, Harold, "Metallurgical Aspects of the Failure of the Point Pleasant Bridge," *Journal of Testing and Evaluation*, JTEVA, Vol. 1, No. 2, March 1973, pp. 152-161.

ABSTRACT: Examination of the fractured eyebar which caused the collapse of the bridge led to the conclusion that a stress-corrosion crack had penetrated to a depth of 3/8 in. during the 40 years that the bridge was in service. This flaw was sufficient to initiate fracture across the remainder of the 16 in.² area of the lower limb of the eye due to the high local stress and the low fracture toughness of the steel.

KEY WORDS: corrosion, stress corrosion, cracking (fracturing), fractures (materials), mechanical properties, microstructure, tensile properties, fatigue (materials), stress corrosion tests, humidity, toughness

- be considered under three principal categories;
1. Examination of the fractures in eyebar 330 and the metallographic investigation of the material close to the initial fracture.
 2. Evaluation of the mechanical properties of the eyebar material including fracture toughness and resistance to crack propagation under fatigue and steady load conditions.
 3. Electron microprobe and other studies of the surfaces of freshly opened cracks in the eyes. As some of this work has previously been reported, only a brief account of the results will be given here.

4. The fracture resulted from a combination of factors; in the absence of any of these it probably would not have occurred. These are; a) the high hardness of the steel which rendered it susceptible to stress-corrosion cracking; b) the close spacing of the components in the joint which made it impossible to apply paint to the most highly stressed region of the eye, yet provided a crevice in this region where water could collect; c) the high design load in the eyebar chain, which resulted in a local stress at the inside of the eye greater than the yield strength of the steel; d) the low fracture toughness of the steel which permitted the initiation of complete fracture from the slowly propagating stress-corrosion crack when it had reached a depth of only 0.12 in.

157

4. The fracture resulted from a combination of factors; in the absence of any of these it probably would not have occurred. These are:

The fracture resulted from a combination of factors; in the absence of any of these it probably would not have occurred. These are:

red. ed it g of pply ided high res at the inside of the eye greater than the yield strength of the steel; d) the low fracture toughness of the steel which permitted the initiation of complete fracture from the slowly propagating stress-corrosion crack when it had reached a depth of only 0.12 in.

158

4. The fracture resulted from a combination of factors; in the absence of any of these it probably would not have occurred. These are; a) **The high hardness of the steel which rendered it susceptible to stress-corrosion cracking**; b) the close spacing of the components in the joint which made it impossible to apply paint to the most highly stressed region of the eye, yet provided a crevice in this region where water could collect; c) the high design load in the eyebar chain, which resulted in a local stress at the inside of the eye greater than the yield strength of the steel; d) the low fracture toughness of the steel which permitted the initiation of complete fracture from the slowly propagating stress-corrosion crack when it had reached a depth of only 0.12 in.

159

4. The fracture resulted from a combination of factors; in the absence of any of these it probably would not have occurred. These are; b) **The close spacing of the components in the joint which made it impossible to apply paint to the most highly stressed region of the eye, yet provided a crevice in this region where water could collect**; c) the high design load in the eyebar chain, which resulted in a local stress at the inside of the eye greater than the yield strength of the steel; d) the low fracture toughness of the steel which permitted the initiation of complete fracture from the slowly propagating stress-corrosion crack when it had reached a depth of only 0.12 in.

160

4. The fracture resulted from a combination of factors: in the absence of a design stress concentration, the fracture would not have occurred. The fracture occurred because of the high design load in the eyebar chain, which resulted in a local stress at the inside of the eye greater than the yield strength of the steel.

at the inside of the eye greater than the yield strength of the steel; d) the low fracture toughness of the steel which permitted the initiation of complete fracture from the slowly propagating stress-corrosion crack when it had reached a depth of only 0.12 in.

161

4. The fracture resulted from a combination of factors: in the absence of a design stress concentration, the fracture would not have occurred. The fracture occurred because of the high design load in the eyebar chain, which resulted in a local stress at the inside of the eye greater than the yield strength of the steel. The low fracture toughness of the steel permitted the initiation of complete fracture from the slowly propagating stress-corrosion crack when it had reached a depth of only 0.12 in. [3 mm].

162





165



166



167

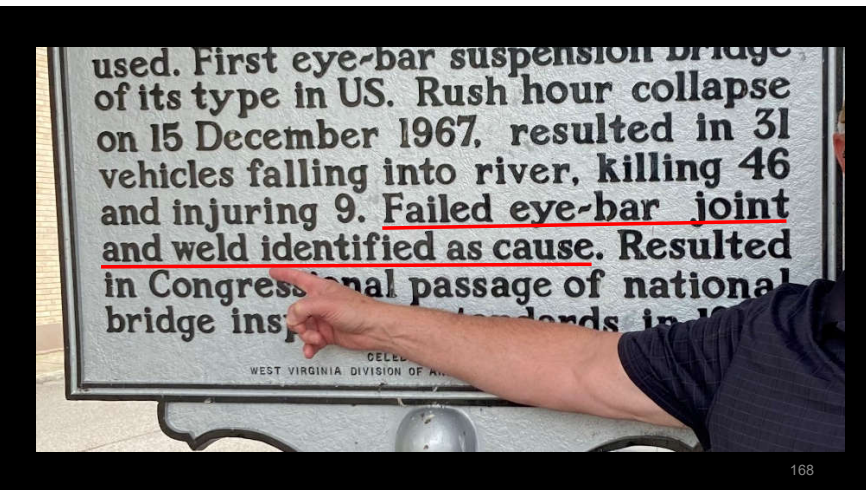

168

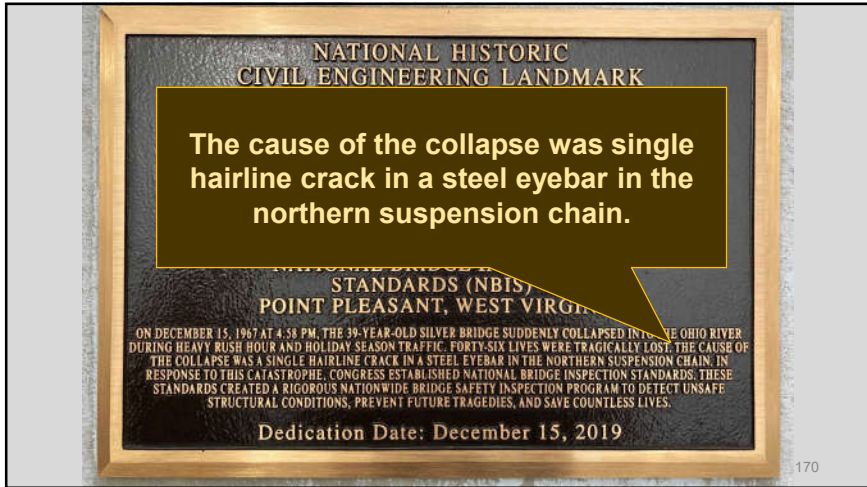
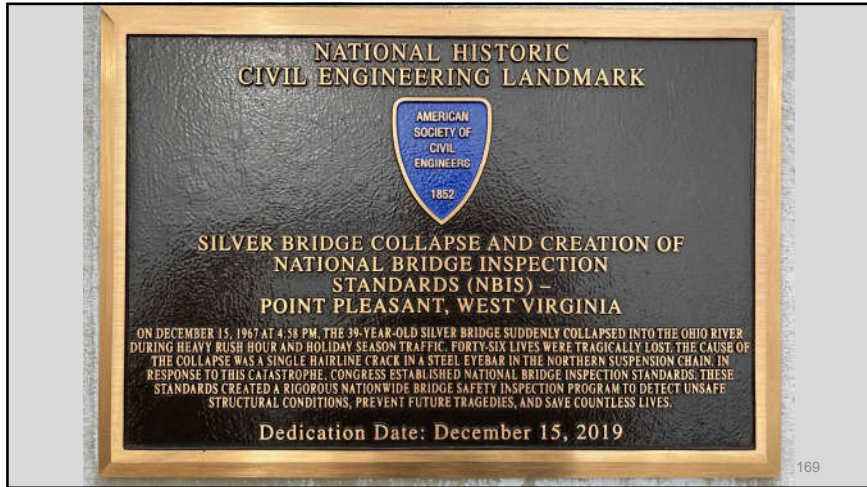

Brittle Fracture: Another View Outline

- Case studies involving brittle fracture
 - Case 1: Liberty ships
 - Case 2: Silver bridge
 - ➔ • Case 3: Ingram barge
 - Case 4: Hoan bridge



Smarter. Stronger. Steel.



Martha R. Ingram Barge

- January 10, 1972
- 584 foot [178 m]
- Air temperature 45 °F [7 °C]
- In service for 9 months

176



Martha R. Ingram Barge

- January 10, 1972
- 584 foot [178 m]
- Air temperature 45 °F [7 °C]
- In service for 9 months
- Unusual loading: 2.5X design load, 24 ksi [165 MPa]

180

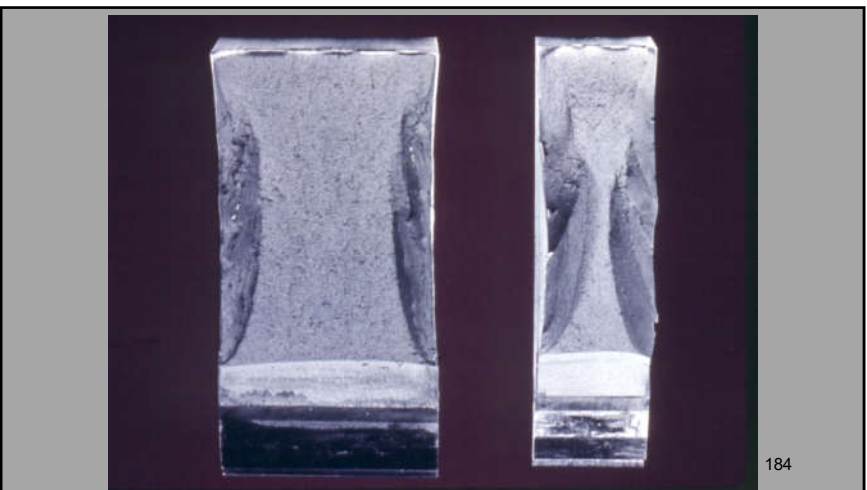
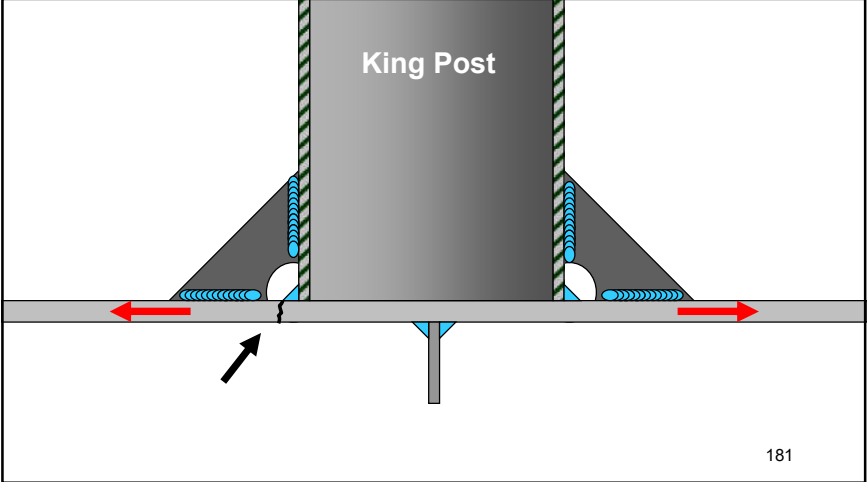

Martha R. Ingram Barge

- January 10, 1972
- 584 foot [178 m]
- Air temperature 45 °F [7 °C]
- In service for 9 months
- Unusual loading: 2.5X design load, 24 ksi [165 MPa]
- 55 ft-lbs [74 J] at service temperature
- No pre-existing flaws were observed

185

Barsom/Rolfe: FRACTURE AND FATIGUE CONTROL IN STRUCTURES



...the primary cause of failure was established to be an unusually high loading stress caused by improper ballasting at a highly constrained welded detail.

186

Barsom/Rolfe: FRACTURE AND FATIGUE CONTROL IN STRUCTURES



Thus, heavily constrained structures, such as the Ingram Barge, can fail under severe loads even though the inherent notch toughness and ductility may be very good. In contrast, well-designed simple structures can operate successfully at temperatures where their notch toughness may be very low. Thus, constraint and loading are the key factors in prevention of brittle fracture.

187

Martha R. Ingram Barge

No amount of inspection would have solved this problem.

- January 10, 1972
- 584 foot [178 m]
- Air temperature 45 °F [7 °C]
- In service for 9 months
- Unusual loading: 2.5X design load, 24 ksi [165 MPa]
- 55 ft-lbs [74 J] at service temperature
- No pre-existing flaws were observed

188

**Brittle Fracture: Another View
Outline**

- **Case studies involving brittle fracture**
 - **Case 1: Liberty ships**
 - **Case 2: Silver bridge**
 - **Case 3: Ingram barge**
 - ➔ • **Case 4: Hoan bridge**



Hoan Bridge

- Built 1972, Opened 1977
- “The Bridge to Nowhere”
- Tied Arch
- Total length: 1.9 miles (3058 m)
- Longest span: 607 feet (185 m)
- December 2000: major fracture discovered

191

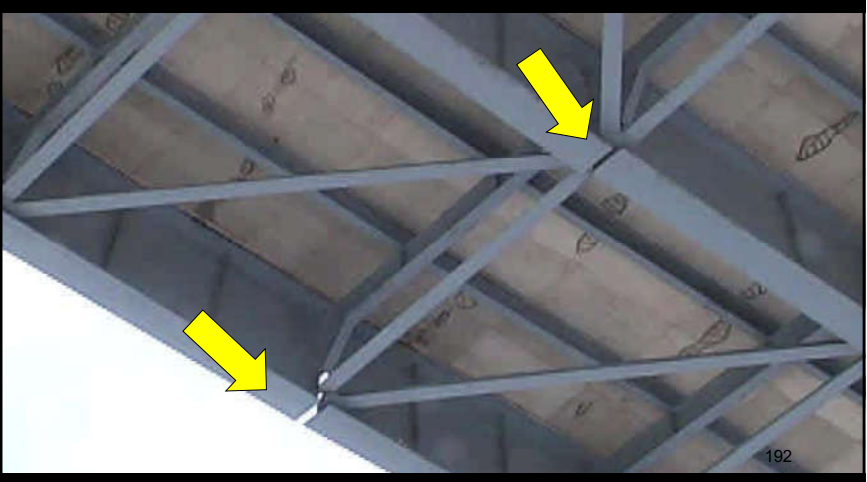

192

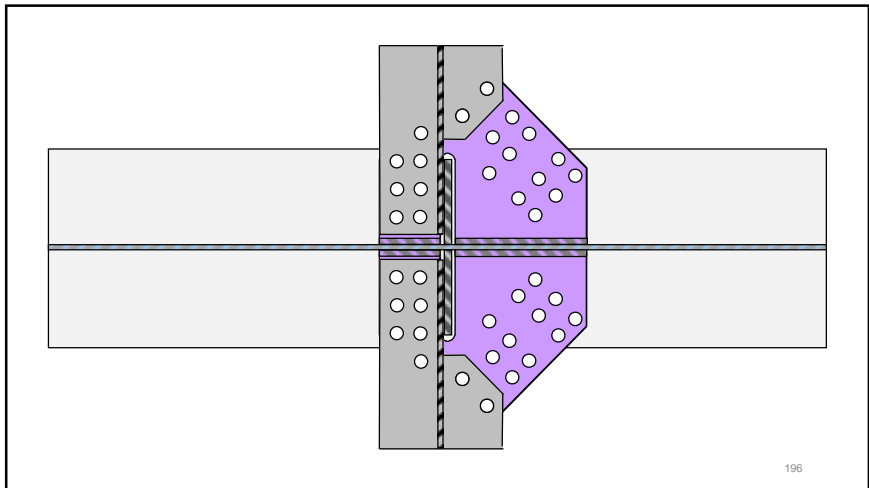
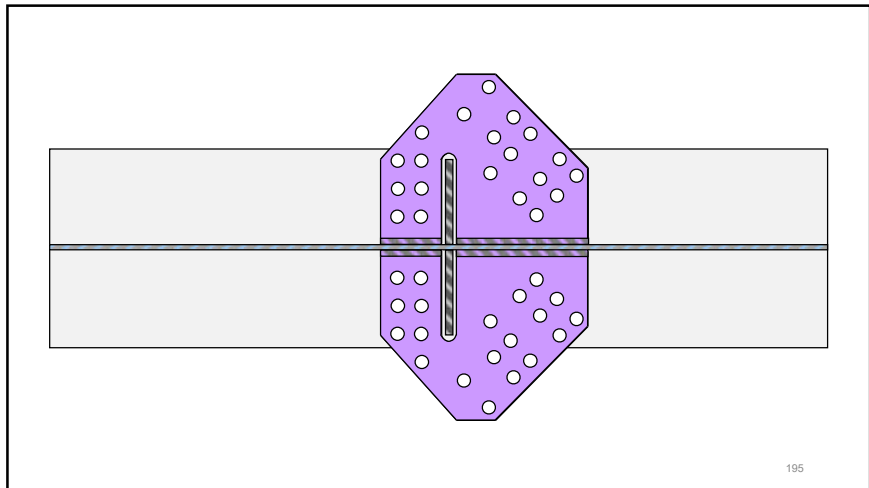
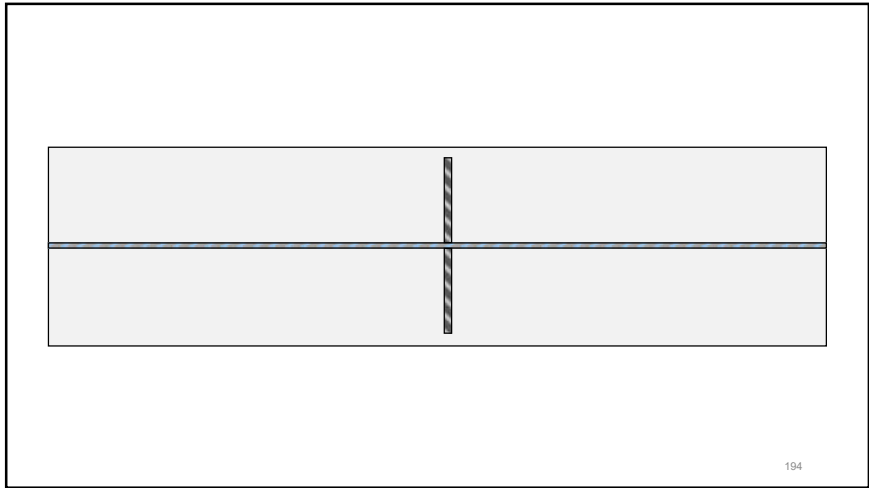
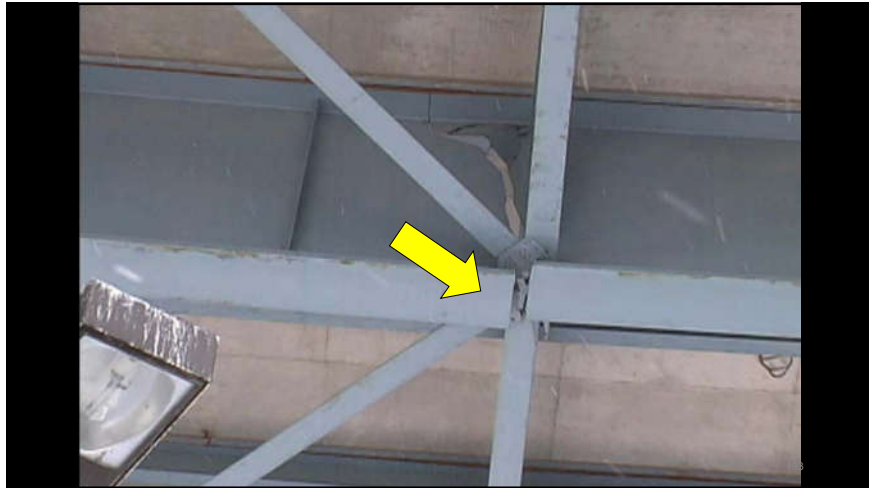

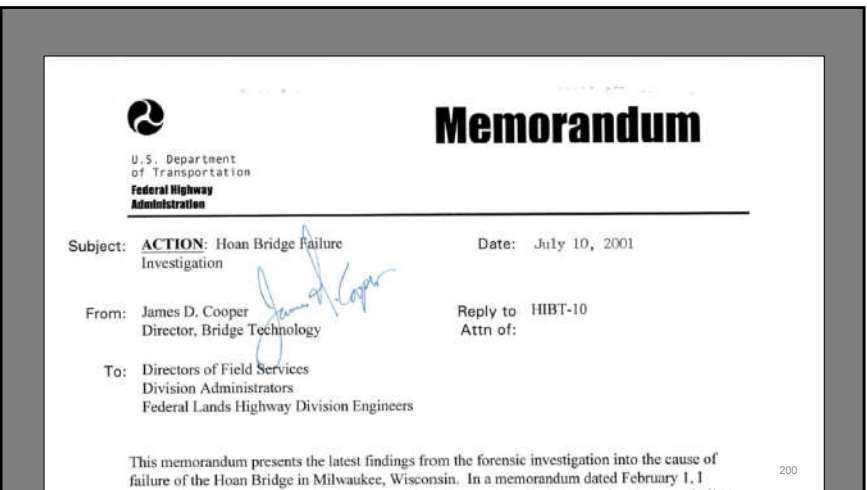
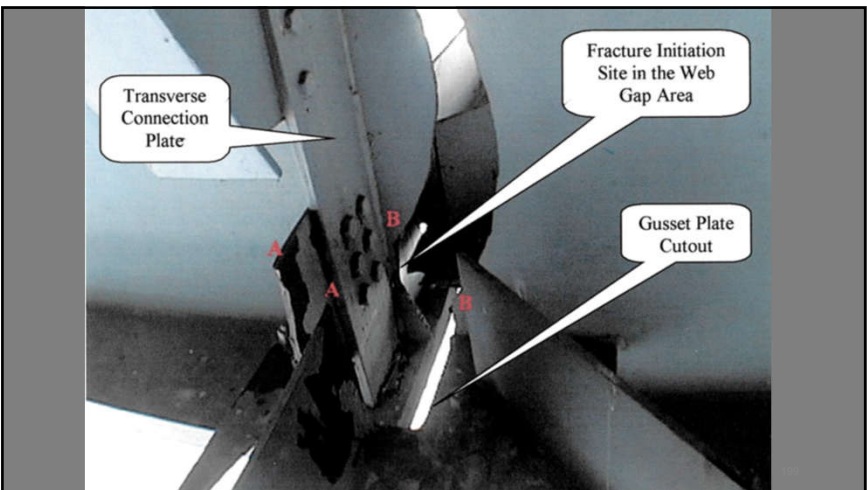
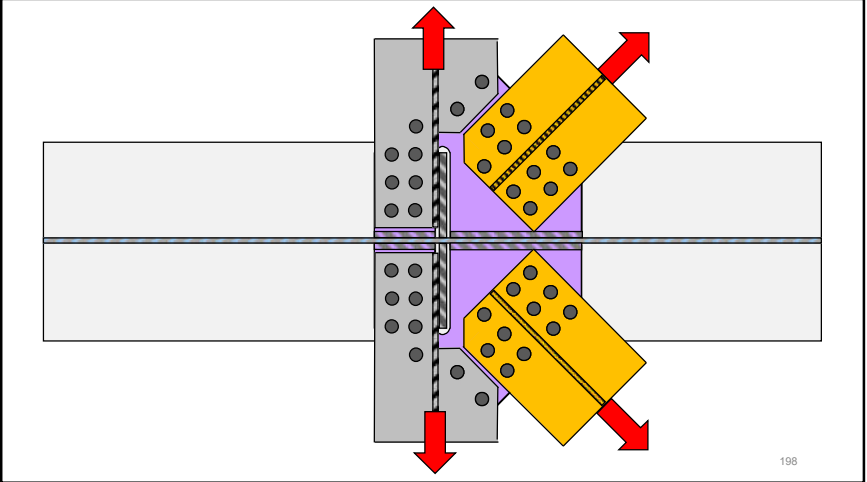
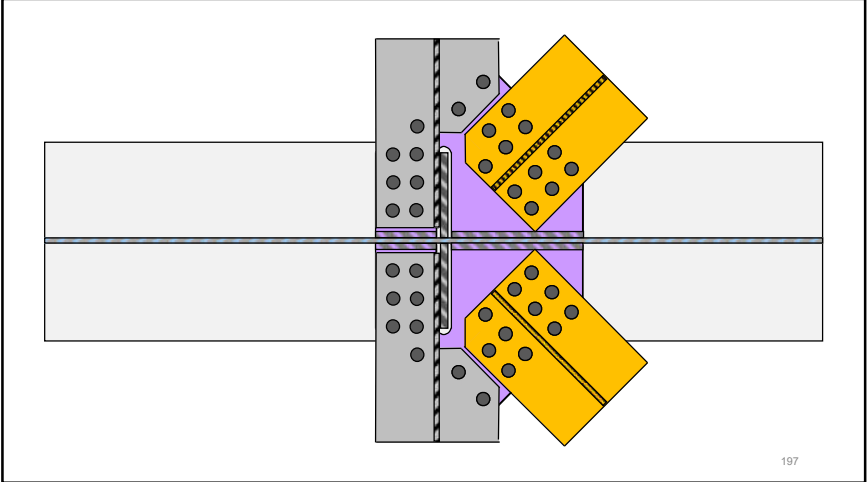

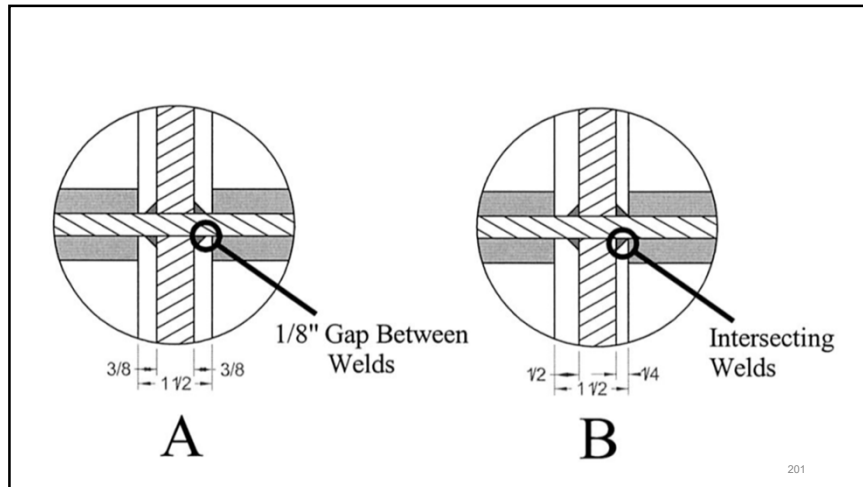

“...the primary cause of failure of the Hoan Bridge is the joint detail used to connect the lateral bracing system to the main girder webs.”

The team concluded that the primary cause of failure of the Hoan Bridge is the joint detail used to connect the lateral bracing system to the main girder webs. Some specific details of the joint created a condition that reduced the fracture resistance and made it vulnerable to premature failure. Research is indicating that this vulnerability is not an inherent problem with this class of joint, but that it is related to the specific details used in the Hoan Bridge.

“Some specific details of the joint created a condition that reduced the fracture resistance and make it vulnerable to premature failure.”

202

“There was no evidence of fatigue cracking prior to fracture initiation. This indicates that there was not observable damage prior to the sudden fracture.”

- There was no evidence of fatigue cracking prior to fracture initiation. This indicates that there was no observable damage prior to the sudden fracture. Even the most rigorous fracture critical inspection would not have provided warning of the impending fracture.
- The web material properties met modern standards for A36 steel. Toughness met the 2001 AASHTO requirements for zone 2, fracture critical use.
- The flange material properties met modern properties for A588 steel. Toughness met the 2001 AASHTO requirements for zone 2, non-fracture critical use.

203

“Toughness met the 2001 AASHTO requirements for zone 2....” (note: FCM for the A36, non-fracture critical for A588.)

- There was no evidence of fatigue cracking prior to fracture initiation. This indicates that there was no observable damage prior to the sudden fracture. Even the most rigorous fracture critical inspection would not have provided warning of the impending fracture.
- The web material properties met modern standards for A36 steel. Toughness met the 2001 AASHTO requirements for zone 2, fracture critical use.
- The flange material properties met modern properties for A588 steel. Toughness met the 2001 AASHTO requirements for zone 2, non-fracture critical use.

204

“A narrow gap between the gusset plate and the transverse connection/stiffener plate created a local triaxial constraint conditions and increased the stiffness in the web gap region at the fracture initiation site.

- A narrow gap between the gusset plate and the transverse connection/stiffener plate created a local triaxial constraint condition and increased the stiffness in the web gap region at the fracture initiation site. This constraint prevented yielding and redistribution of the local stress concentrations occurring in this region. As a result, the local stress state in the web gap was forced well beyond the yield strength of the material. Under triaxial constraint, the apparent fracture toughness of the material is reduced and brittle fracture can occur under service conditions where ductile behavior is normally expected.

205

• **Joint Details**

The primary cause of fracture initiation was determined to be the geometry and fabrication tolerance of the joint where the lateral bracing frames into the web. The joint was detailed with a narrow web gap that caused a local high constraint, increased stiffness, and reduced the apparent fracture resistance. As ideally detailed, the joint has only 1/8 in. separating the welds on the two plates. The fabrication tolerance resulted in reduced gaps as well as intersecting welds in many locations throughout the structure. Stress analysis showed that the intersecting welds increased the rigidity of the joint and made the constraint problem worse. This non-ductile behavior in the joint caused by a triaxial constraint and state of stress has never been documented before as being a potential problem in bridge detailing. This is the first time this problem is being reported.

Additionally, the “K” pattern in the lower lateral brace system introduces an axial force in the girder to satisfy equilibrium in the joint area. A stress analysis showed that this increased the live load stress range at the outside ends of the shelf plate, but that there was little effect in the gap area.

206

• **Joint Details**

The primary cause of fracture initiation was determined to be the geometry and fabrication tolerance of the joint where the lateral bracing frames into the web. The joint was detailed with a narrow web gap that caused a local high constraint, increased stiffness, and reduced the apparent fracture resistance. As ideally detailed, the joint has only 1/8 in. separating the welds on the two plates. The fabrication tolerance resulted in reduced gaps as well as intersecting welds in many locations throughout the structure. Stress analysis showed that the intersecting welds increased the rigidity of the joint and made the constraint problem worse. This non-ductile behavior in the joint caused by a triaxial constraint and state of stress has never been documented before as being a potential problem in bridge detailing. This is the first time this problem is being reported.

“This non-ductile behavior in the joint caused by a triaxial constraint and state of stress has never been documented before as being a potential problem in bridge detailing. This is the first time this problem is being reported.”

in the girder to satisfy equilibrium in the joint area. A stress analysis showed that this increased the live load stress range at the outside ends of the shelf plate, but that there was little effect in the gap area.

207

Evaluation of Steel Bridge Details for Susceptibility of Constraint-Induced Fracture

Publication No. FHWA-HIF-21-046
September 2021

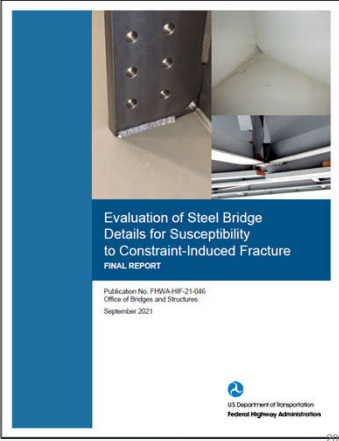

208

Evaluation of Steel Bridge Details for Susceptibility of Constraint-Induced Fracture

TECHNICAL REPORT DOCUMENTATION PAGE

1. Report No. FHWA-HIF-21-046	2. Government Accession No.	3. Recipient's Catalog No.
4. Evaluation of Steel Bridge Details for Susceptibility to Constraint-Induced Fracture	5. Report Date	
	6. Performing Organization Code:	
7. Author(s) Domenic Coletti, P.E., Brandon Chavel, P.E., Ph.D., Anthony Ream, P.E., Caroline Bennett, P.E., Ph.D., Rob Connor, P.E., Ph.D., Karl Frank, P.E., Ph.D., Michael Grubb, P.E., Finn Hubbard, P.E., Ronnie Medlock, P.E., Duane Miller, Sc.D., P.E., Frank Russo, P.E., Ph.D.	8. Performing Organization Report No.	
	9. Performing Organization Name and Address HDR Engineering, Inc. 301 Grant Street, Suite 1700 Pittsburgh, PA 15219-1408	10. Work Unit No.
	11. Contract or Grant No. DTFH61-14-D-00049	

209

Evaluation of Steel Bridge Details for Susceptibility of Constraint-Induced Fracture

16. Abstract
 This report explains how to evaluate steel bridge details for susceptibility to constraint-induced fracture. The report begins with a review of fundamental principles of ductile behavior of steel structures and the effects of constraint and stress triaxiality. A brief history of constraint-induced fractures of steel bridges in the United States and a review of published research, policies, and practices is also provided. The report then presents a possible method for evaluating a steel detail for the presence the three conditions associated with elevated susceptibility to constraint-induced fracture: high tensile stresses (including residual stress effects), a high degree of constraint, and planar discontinuities approximately perpendicular to the primary flow of tensile stresses. Next, a series of commonly used steel bridge details are evaluated to illustrate the procedure and to provide a baseline library of evaluations. Redesign, inspection, retrofit, and repair options for problematic details are briefly discussed. The report also presents general design details and construction considerations and possible future research topics.

210

Evaluation of Steel Bridge Details for Susceptibility of Constraint-Induced Fracture

16. This report explains how to evaluate steel bridge details for susceptibility to constraint-induced fracture. The report begins with a review of fundamental principles of ductile behavior of steel structures and the effects of constraint and stress triaxiality.

211

- Evaluation of Steel Bridge Details for Susceptibility of Constraint-Induced Fracture**
- The findings in this report are:
- Steel bridge details featuring intersecting welds are not necessarily at elevated susceptibility to CIF.
 - Three conditions typically contribute to elevated susceptibility of steel bridge details to CIF: a high net tensile stress, a high degree of constraint, and a planar discontinuity approximately perpendicular to the primary flow of tensile stress.
 - Evaluating details with respect to criteria rooted in a technical understanding of CIF can help bridge owners identify details that are candidates for redesign and retrofit.
 - Retrofitting and redesigning details with intersecting welds without proper understanding of CIF can lead owners to undertake design and/or retrofit strategies that may result in poorer, not better, performance.
- 212

Evaluation of Steel Bridge Details for Susceptibility of Constraint-Induced Fracture

The Three conditions typically contribute to elevated susceptibility of steel bridge details to CIF: a high net tensile stress, a high degree of constraint, and a planar discontinuity approximately perpendicular to the primary flow of tensile stress.

213

Evaluation of Steel Bridge Details for Susceptibility of Constraint-Induced Fracture

CHAPTER 3 - STRESS TRIAXIALITY, CONSTRAINT, AND SUSCEPTIBILITY TO CIF

3.1 FUNDAMENTAL PRINCIPLES OF DUCTILE BEHAVIOR OF STEEL STRUCTURES AND THE EFFECTS OF CONSTRAINT AND STRESS TRIAXIALITY

While it has often been said that steel is an inherently ductile material, that ductile nature can be compromised if a structure is detailed in manner that inhibits the typical stress-strain behavior of the material. Clarification of this concept is instructive in understanding the nature and causes of CIF.

214

Evaluation of Steel Bridge Details for Susceptibility of Constraint-Induced Fracture

CHAPTER 3 - STRESS TRIAXIALITY, CONSTRAINT, AND SUSCEPTIBILITY TO CIF

3.1 While it has often been said that steel is an inherently ductile material, that ductile nature can be compromised if a structure is detailed in [a] manner that inhibits the typical stress-strain behavior of the material.

215

Evaluation of Steel Bridge Details for Susceptibility of Constraint-Induced Fracture

Connor and Lloyd (2017) describe three conditions that contribute to the susceptibility of a detail to CIF:

1. "There must be an elevated level of tensile residual stress locked into the local area. While the dominating contribution is residual stresses from welding, other factors contribute to a lesser degree, such as dead load and erection stress. As is well documented, residual stresses due to welding can easily reach the yield strength of the base metal.
2. "The joint must be highly constrained, resulting in a three-dimensional state of stress that prevents plastic flow, as would [otherwise] occur in a simple uniaxial stress state.
3. "Localized area of stress concentration that intensifies dead load and live load stress level."

216

Maintenance Actions to Address Fatigue Cracking in Steel Bridges Structures

PROPOSED GUIDELINES AND COMMENTARY

Connor and Lloyd
 March, 2017

Maintenance Actions to Address Fatigue Cracking in Steel Bridge Structures
 PROPOSED GUIDELINES AND COMMENTARY

Prepared for:
 NCHRP Transportation Research Board of The National Academies

Prepared by:
 Robert J. Connor and James B. Lloyd
 Purdue University
 West Lafayette, Indiana

March, 2017

The information contained in this report was prepared as part of NCHRP Report 707-704
 of National Cooperative Highway Research Program.
 (NCHRP-707) The report is the property of the National Cooperative Highway Research Program. The information should be used for research purposes only and should not be used for design purposes.

217

Maintenance Actions to Address Fatigue Cracking in Steel Bridges Structures

There are three contributing elements to constraint-induced fracture, characteristic of all CIF-prone details, which when any one of the elements is missing, the likelihood of constraint-induced fracture drops dramatically. Figure 7.3 illustrates these elements, conceptually showing that the risk of CIF exists at the intersection of the three elements.

1. There needs to be a localized area of stress concentration that intensifies the dead and live load stress level. The presence of defects within the weld, as well as certain geometry of the connection can both act as discontinuities that interrupt stress flow and cause concentrations.
2. The joint must be highly constrained, resulting in a three dimensional state of stress that prevents plastic flow, as would occur in a simple uniaxial stress state.
3. There must be an elevated level of tensile residual stresses locked into the local area. While the dominating contributor are residual stresses from welding, other factors contribute to a lesser degree, such as dead load and erection stress. As is well documented, residual stresses due to welding can easily reach the yield strength of the base metal.

218

Maintenance Actions to Address Fatigue Cracking in Steel Bridges Structures

There are three contributing elements to CIF...
 dramatically. Figure 7.3 illustrates these elements, conceptually showing that the risk of CIF exists at the

1. There needs to be a localized area of stress concentration...
concentrations.
2. The joint must be highly constrained...
3. There must be an elevated level of tensile residual stress.

219

Maintenance Actions to Address Fatigue Cracking in Steel Bridges Structures

Figure 7.3 Defining characteristics of CIF details

220

Evaluation of Steel Bridge Details for Susceptibility of Constraint-Induced Fracture

Subsequent assessments of the Hoan Bridge fracture, studies of similar fractures in other bridges, and other related research and investigations, largely supported this conclusion (e.g., Fisher et al. 2001; Wright et al., 2003). The cause of the Hoan Bridge fracture was CIF originating in details with high-stress triaxiality, which resulted from:

- a high level of constraint, provided by the various attachments locally constraining the ability of the web to yield;
- high levels of tensile stress associated with residual stresses induced by welding of the various attachments to the web; and
- crack-like geometry, specifically where the so-called “web gap” (a constraint-relief gap) between the lateral bracing connection plate (the “gusset plate” in Figure 19) and the cross-frame connection plate (the “transverse connection plate” in Figure 19) was very narrow.

The steel was found to exhibit reasonable toughness with no evidence of fatigue cracking prior to the CIF event.

221

Evaluation of Steel Bridge Details for Susceptibility of Constraint-Induced Fracture

The cause of the Hoan Bridge fracture as CIF originating in details with high-stress triaxiality, which resulted from:

- A high level of constraint...
- High levels of tensile stress associated with residual stressed induced by welding...
- A crack-like geometry...

The steel was found to exhibit reasonable toughness with no evidence of fatigue cracking prior to the CIF event.

222

Evaluation of Steel Bridge Details for Susceptibility of Constraint-Induced Fracture

At the same time, the non-binding Reference Manual for FHWA/NHI *Design and Evaluation of Steel Bridges for Fatigue and Fracture – Reference Manual* (Russo et al., 2016), provides a suggestion to use a wider constraint-relief gap, and directly quotes language from the same article of the previous 7th Edition of the AASHTO BDS, which is different from Article 6.6.1.2.4 of the AASHTO BDS, 8th Edition (23 CFR 625.4(d)(1)(v)):

To the extent practical, welded structures shall be detailed to avoid conditions that create highly constrained joints and crack-like geometric discontinuities that are susceptible to constraint-induced fracture. Welds that are parallel to the primary stress but interrupted by intersecting members shall be detailed to allow a minimum gap of 1 inch between weld toes.

223

Evaluation of Steel Bridge Details for Susceptibility of Constraint-Induced Fracture

At the same time, the non-binding Reference Manual for FHWA/NHI *Design and Evaluation of Steel Bridges for Fatigue and Fracture – Reference Manual* (Russo et al., 2016), provides a suggestion to use a wider constraint-relief gap, and directly quotes language from the same

To the extent practical, welded structures shall be detailed to avoid conditions that create highly constrained joints and crack-like geometric discontinuities that are susceptible to constraint-induced fracture.

224

Case Study Lessons

Liberty Ships

- Notches are bad
- Square corners are bad
- Notch sensitive steel is bad
- Good design is important
- Good fabrication is important
- Notch tough steel is helpful



225

Case Study Lessons

Silver Bridge

- High hardness, subject to SCC, is bad
- High stresses are bad
- Initial fabrication discontinuities are bad
- Cyclic loading can extend initial discontinuities
- Low fracture toughness is bad
- Non-redundant designs can fail catastrophically



226

Case Study Lessons

Ingram Barge

- Overloading of barges is bad
- Highly constrained details are bad
- Constraint can induce fracture with no pre-existing cracks
- Good notch toughness does not preclude fracture in highly constrained details



227

Case Study Lessons

Hoan Bridge

- Highly constrained details are bad
- Constraint can induce fracture with no pre-existing cracks
- Good notch toughness does not preclude fracture in highly constrained details



228

Case Study Lessons				
Case Study	Detailing/Constraint	Notches/Cracks	Loading	Material Toughness
Liberty Ships	✓	✓		✓
Silver Bridge		✓	✓	✓
Ingram Barge	✓		✓	
Hoan Bridge	✓	✓		

229

AISC 360-16 Specifications for Structural Steel Buildings

Commentary A3.1a

“Good workmanship and good design details incorporating joint geometry that avoids severe stress concentrations are generally the most effective means of providing fracture-resistant construction.”

230

Barsom/Rolfe: FRACTURE AND FATIGUE CONTROL IN STRUCTURES

“Fracture mechanics has shown that because of the interaction among materials, design, fabrication, and loading, brittle fractures cannot be eliminated in structures merely by using materials with improved notch toughness. The designer still has the fundamental responsibility for the overall safety and reliable of his or her structure.”

231

Evaluation of Steel Bridge Details for Susceptibility of Constraint-Induced Fracture

To the extent practical, welded structures shall be detailed to avoid conditions that create highly constrained joints and crack-like geometric discontinuities that are susceptible to constraint-induced fracture.

232

AISC Design Guide 21, 2nd Edition

Welded Connections—
A Primer for Engineers

233

DESIGN GUIDE 21

It is not possible to simply quantify mathematically the degree of restraint offered by the surrounding steel, but an intuitive feel can be developed.

234

Flange Splice

3 in. (75 mm) thick, 10 in. (250 mm) wide,
Two 40 foot (13 m) lengths

235

Flange Splice

LOW CONSTRAINT

3 in. (75 mm) thick, 10 in. (250 mm) wide,
Two 40 foot (13 m) lengths

236

Wide Flange Splice

W14 X 730
5 in. (125 mm) thick flange, 3 in. (75 mm thick web)

237

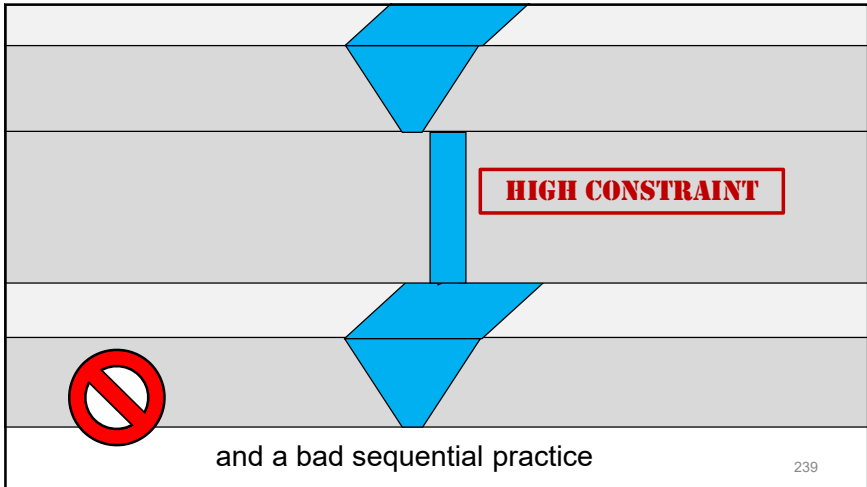
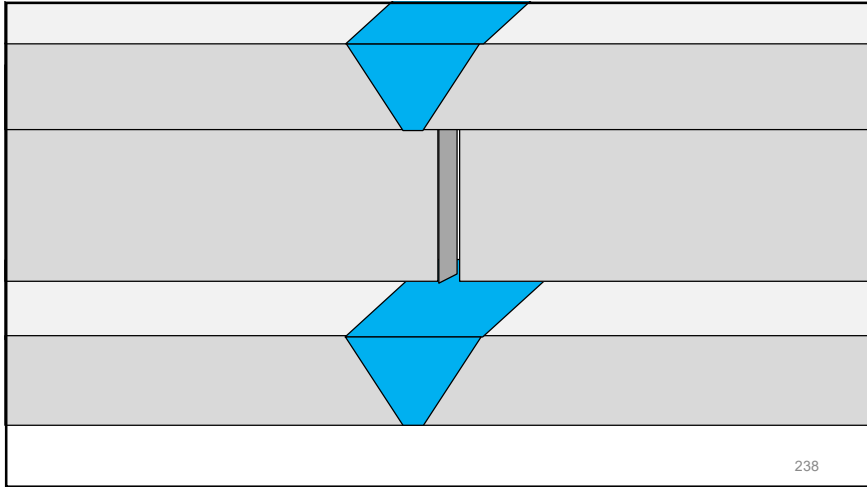

Brittle Fracture: Another View
Outline

- Definition of brittle fracture
- Significance of brittle fracture
- Factors affecting brittle fracture
- Case studies involving brittle fracture
- ➔ • Designing to prevent brittle fracture

**Smarter.
Stronger.
Steel.**



Improving Fracture Resistance in Cold Temperature Applications

$$K_c > \sqrt{b \sqrt{f_a}}$$

12 sub-principles

Principle 1: Reduce Stress

- 1.1 Reduce the loads/forces.
- 1.2 Increase the resisting area/section.
- 1.3 Provide easy paths for stress flow through the member.
- 1.4 Provide gradual changes in stiffness and section.

242

Improving Fracture Resistance in Cold Temperature Applications

$$K_c > \sqrt{b \sqrt{f_a}}$$

Principle 1: Reduce Stress

- 1.5 Eliminate the number and severity of localized stress concentrations.
- 1.6 Locate welded joints at points of low stress when possible.
- 1.7 Avoid the introduction of secondary stresses.
- 1.8 Avoid the introduction of triaxial constraint.

243

Improving Fracture Resistance in Cold Temperature Applications

$$K_c > \sqrt{b \sqrt{f_a}}$$

Principle 1: Reduce Stress

- 1.9 When applicable, consider proof loading.
- 1.10 Consider thermal stress relief.
- 1.11 Provide “contouring” fillet welds at T and corner joints.
- 1.12 Provide a minimum radius at copes and re-entrant corners.

244

Improving Fracture Resistance in Cold Temperature Applications

$$K_C > \sqrt{f_a}$$

14 sub-principles

Principle 2: Reduce Flaw Size

- 2.1 Select materials with good weldability.
- 2.2 Provide ample access for welding and inspection.
- 2.3 Carefully inspect incoming steel.
- 2.4 Visually inspect cut surfaces.
- 2.5 Control the quality of cut surfaces.

245

Improving Fracture Resistance in Cold Temperature Applications

$$K_C > \sqrt{f_a}$$

Principle 2: Reduce Flaw Size

- 2.6 Drill holes versus punching them, or ream punched holes.
- 2.7 Take measures to eliminate all forms of fabrication-related weld cracking.
- 2.8 Use weld tabs on groove welds, where practical, and remove them after welding.
- 2.9 Control tack welding

246

Improving Fracture Resistance in Cold Temperature Applications

$$K_C > \sqrt{f_a}$$

Principle 2: Reduce Flaw Size

- 2.10 Require continuous steel backing (where backing is needed and when left in place).
- 2.11 Remove steel backing, as applicable.
- 2.12 Consider roots of fillets and PJP groove welds in cruciform joints.
- 2.13 Inspect welds for surface breaking flaws.
- 2.14 Inspect welds for internal flaws.

247

Improving Fracture Resistance in Cold Temperature Applications

$$K_C > \sqrt{f_a}$$

6 sub-principles

Principle 3: Increase Material Toughness

- 3.1 Specify materials with known toughness.
- 3.2 Realize that steel is not purely isotropic.
- 3.3 Recognize areas of potential low toughness in steel members.
- 3.4 Increase the temperature shift.
- 3.5 Properly establish the operating temperature of the steel structure or weldment.
- 3.6 Develop a limit for low temperature operation.

248

Improving Fracture Resistance in Cold Temperature Applications

$K_C > \sqrt{f_a}$ **5 sub-principles**

Principle 4: Increase Fatigue Life

- 4.1 Reduce the stress range.
- 4.2 Use improved fatigue details.
- 4.3 Limit the life of the weldment.
- 4.4 Use fatigue life enhancement techniques.
- 4.5 Recognize the role of steel strength in fatigue of weldments.

249

Improving Fracture Resistance in Cold Temperature Applications

$K_C > \sqrt{f_a}$ **6 Principles**

Principle 5: Additional Considerations

- 5.1 Consider the effects of corrosion.
- 5.2 Develop and implement a realistic maintenance program.
- 5.3 Develop a realistic in-service inspection program.

250

Improving Fracture Resistance in Cold Temperature Applications

$K_C > \sqrt{f_a}$

Principle 5: Additional Considerations

- 5.4 Consider the use of structural redundancy.
- 5.5 Recognize there are no secondary members in welded construction.
- 5.6 Carefully select the appropriate strength level for the steel.

251

Improving Fracture Resistance in Cold Temperature Applications

$K_C > \sqrt{f_a}$

43 Ideas For Increased Fracture Resistance

- Principle 1: Reduce Stress (12)
- Principle 2: Reduce Flaw Size (14)
- Principle 3: Increase Material Toughness (6)
- Principle 4: Increase Fatigue Life (5)
- Principle 5: Additional Considerations (6)

1 Involves Specification of Higher Material Toughness

252

**Brittle Fracture: Another View
Outline**

- Definition of brittle fracture
- Significance of brittle fracture
- Factors affecting brittle fracture
- Case studies involving brittle fracture
- Designing to prevent brittle fracture



**Brittle Fracture:
Another View**

Duane K. Miller, P.E., Sc.D
The Lincoln Electric Company



AISC | Questions?



CEU / PDH Certificates

For those participating at their own connection...

- Reporting attendance is not necessary.
- Certificates will be issued based on AISC’s attendance record.
- You will be receiving certificates via email from registration@aisc.org.



CEU / PDH Certificates

For those participating at one connection with a group...

- Main registrant will report attendance via an online form. (The link will be provided in an email from registration@aisc.org)
 - Username: Same as AISC website username.
 - Password: Same as AISC website password.
- Once attendance has been reported, each group member will be receiving certificates via email from registration@aisc.org.



AISC | Thank you

