

AISC Live Webinars

Thank you for joining our live webinar today.
We will begin shortly. Please standby.

Thank you.

Need Help?
Call ReadyTalk Support: 800.843.9166

Field Fixes and Solutions

Marc 14, 2019



**Smarter.
Stronger.
Steel.**

AISC Live Webinars

Today's live webinar will begin shortly. Please stand by.

As a reminder, all lines have been muted. Please type any questions or comments through the chat feature on the left portion of your screen.

Today's audio will be broadcast through the internet.
Alternatively, to hear the audio through the phone, dial:

(888)-378-4398
Passcode: 847951



**Smarter.
Stronger.
Steel.**



AISC Live Webinars

Audio Options

Today's audio will be broadcast through the internet.

Alternatively, to hear the audio through the phone, dial:

(888)-378-4398

Passcode: 847951



AISC Live Webinars

AIA Credit

AISC is a Registered Provider with The American Institute of Architects Continuing Education Systems (AIA/CES). Credit(s) earned on completion of this program will be reported to AIA/CES for AIA members. Certificates of Completion for both AIA members and non-AIA members are available upon request.

This program is registered with AIA/CES for continuing professional education. As such, it does not include content that may be deemed or construed to be an approval or endorsement by the AIA of any material of construction or any method or manner of handling, using, distributing, or dealing in any material or product.

Questions related to specific materials, methods, and services will be addressed at the conclusion of this presentation.



AISC Live Webinars

Copyright Materials

This presentation is protected by US and International Copyright laws. Reproduction, distribution, display and use of the presentation without written permission of AISC is prohibited.

© The American Institute of Steel Construction 2019

The information presented herein is based on recognized engineering principles and is for general information only. While it is believed to be accurate, this information should not be applied to any specific application without competent professional examination and verification by a licensed professional engineer. Anyone making use of this information assumes all liability arising from such use.



AISC Live Webinars

Course Description

Field Fixes and Solutions
March 14, 2019

What do you do when an anchor rod hole is misplaced? Or the columns aren't plumb? More importantly, what can you do to prevent these problems from occurring in the first place? This session covers a wide range of topics and provides the tools and knowledge to not only fix, but also to potentially prevent these field problems. Unlike other webinars or seminars this one is more philosophical than technical in nature based upon many years of practical experience. Topics include:

- What to do when notified about a field problem
- Anchor rods
- Columns and beams
- Reinforcing members and connections
- Fit-up problems
- Member selection guidelines



AISC Live Webinars

Learning Objectives

- List tasks to accomplish after being notified of a field problem.
- Describe safe and efficient field fixes to misplaced anchor rods.
- Describe cost effective reinforcing solutions as a field fix for steel members and connections.
- List solutions to addressing steel member fit-up problems in the field.



Smarter.
Stronger.
Steel.

Field Fixes and Solutions



James Fisher, Ph.D., P.E., Dist.M.ASCE
Estero, Florida



Smarter.
Stronger.
Steel.

Topics

- What to do when notified about a field problem.
- Anchor Rods.
- Columns and Beams.
- Reinforcing Members and Connections.
- Fit-up Problems.
- Member Selection Guidelines.



9

What to do when notified about a field problem

- Make sure you have accurate information.
- Act immediately to avoid delay charges.
- Determine the cause of the problem.
- Is a fix required? (If no money is spent on a fix then there will be no argument as to who pays).
- Think about labor costs in fixes, material is cheap.
- Discuss required paperwork to satisfy all parties.
- Discuss your fee and how it will be paid.



10



General Comment

- Often the field work details are proposed by the steel fabricator or the erector.
- The proposal may be one that was used in the past by the fabricator/erector, but may not be adequate for the conditions on your project.



11

Anchor Rod Problems



12

Anchor Rod Installation Problem Due to Construction Sequence

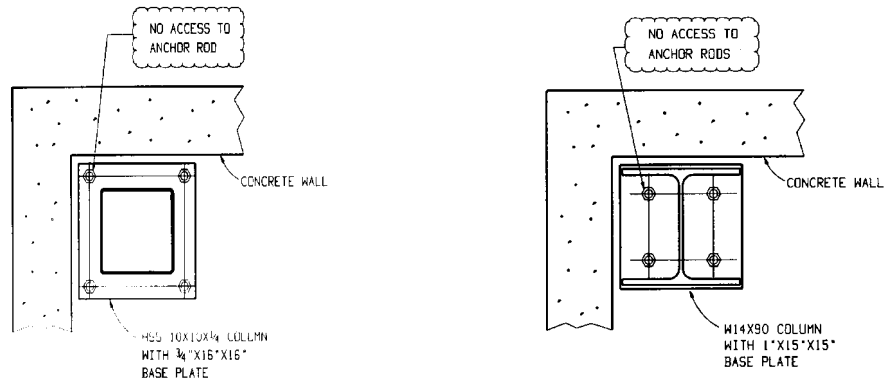

13

Anchor rods too strong



14

Anchor rods too short



15

Anchor rods too short

Solutions:

1. Extend by welding a threaded rod.
2. Use a coupling nut.
3. Cut and use epoxy anchors.
4. Weld base plate to rods (not high strength rods).
5. Perform analysis for nut using the threads engaged.



16

Anchor rods too short

Prevention:

1. Provide a design with ample length and ample thread length.
2. Standardize elevations and flag specials.
3. Do not use high strength steel anchor rods (ASTM 1554-55 ksi or 105 ksi), use larger diameter rods (36 ksi) instead.



17

Anchor Rod Splice Groove Weld

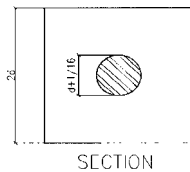
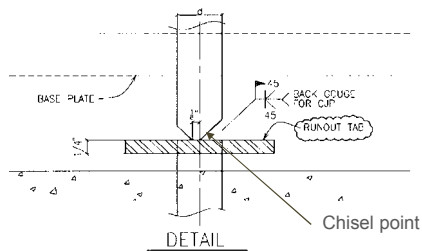

NOTE: CAN TRIM & GRIND RUN OFF TAB AFTER WELDING IF ROD MATERIAL: F1554-36 & 55 WITH SUPPLEMENT S1.



18

Anchor Rod Splice Flare Groove Weld

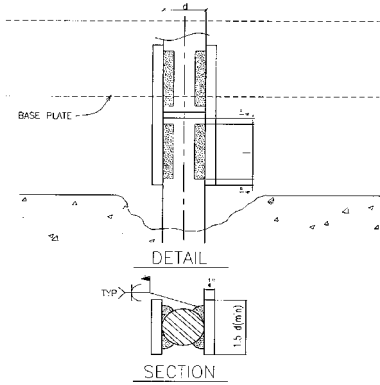

MATERIAL: F1554-36 & 55 WITH SUPPLEMENT S1.



19

Anchor Rod Splice Coupling Nut

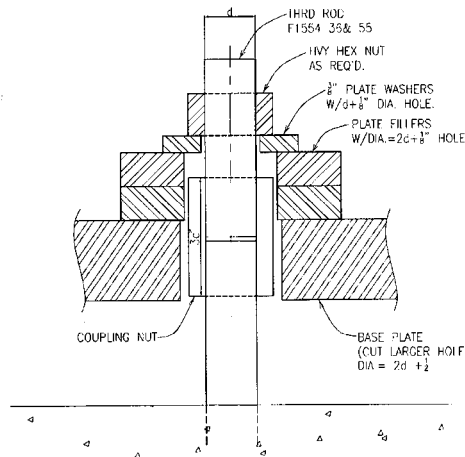

20



Anchor rods too short – Coupling Nut Fix



21

Anchor rods too short – Coupling Nut Fix



22



Google Search: Coupling Nuts

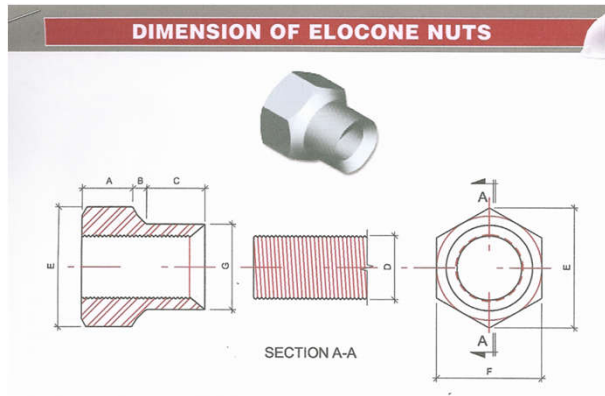

G=1.0" & C= 1½" for ¾
Rod
Photo of Elocone Nut by Canam



23

Anchor rods too long



24

Anchor rods too long

Solutions:

1. Provide washers.
2. Weld rods to base plate if insufficient thread length exists. Use plate washer for large hole.
3. Thread in place.

Prevention:

Provide plenty of extra threads.

Comment:

Since the rod(s) are too long, check for proper embed distance.



25

Anchor rod detail

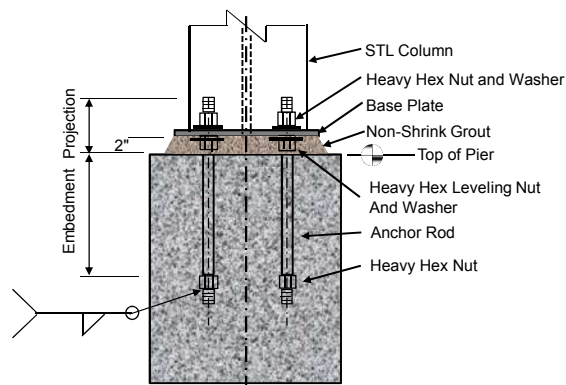

26

Anchor rods bent or not plumb



27

Anchor rods bent or not plumb

Solutions:

1. Cold bend - Gr 36 only.
2. Heat and straighten.
3. If high strength anchor rods - replace.

Prevention:

1. Don't use high strength rods.
2. Provide protection for rods during construction.



28

Anchor rod pattern rotated 90 degrees

Solutions:

Solutions similar to all of the previous solutions.

Prevention:

1. Design the same pattern both directions where possible.
2. Require special inspection for critical settings.



29

Anchor rods in wrong position



30

Anchor rods in wrong position

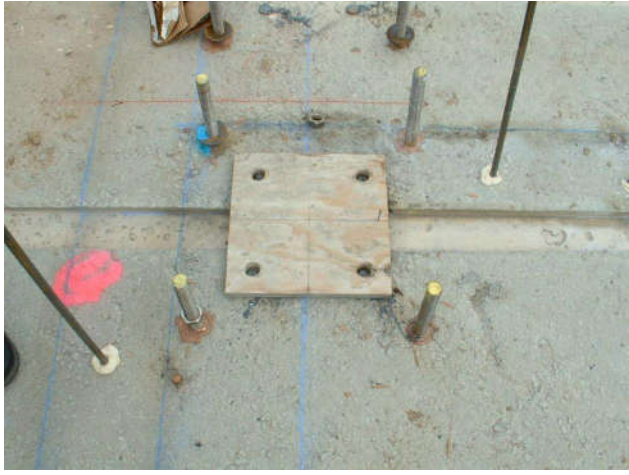

31

Anchor rods in wrong position



32



Anchor rods in wrong position

Solutions:

1. Evaluate the need for the anchor rods.
2. Cut rods and use epoxy anchors.
3. Cut base plate and use plate washers.
4. Fabricate new base plate.
5. Relocate column on base plate.
6. Modify column web or flange as required.
7. Bend rods into position, may require chipping of concrete.



33

Anchor rods in wrong position

Prevention:

1. Use a qualified field engineer to layout the anchor rods.
2. Survey before column fabrication.
3. Use AISC recommended hole sizes.
4. Use symmetric patterns for the anchor rods.
5. Use wood or steel templates firmly fastened to the footing or pier forms.



34



Base Plate Punches Through Leveling Nuts

Solution:

Jack column and grout.

Prevention:

1. Use large thick washers when using leveling nuts.
2. Specify proper grouting time in specifications.
3. Use shim stock or setting plates instead of leveling nuts for large loads.



35

What is the proper specification for anchor rods?

ASTM F1554

Two items of particular interest in 1554 relate to:

Classification, and
Product Marking (color coded).



36



ASTM 1554 - Classifications

• Anchor rods furnished to the ASTM 1554 can be obtained in three grades which denote three steel yield strengths, they are to be color coded as shown:

- 36 ksi - Blue
- 55 ksi – Yellow *
- 105 ksi - Red

The 36 ksi rods, and the 55 ksi rods, can be obtained in diameters up to 4 in. The 105 ksi rods can be obtained up to 3 in. diameters.

*Supplement S1 for weldable material.



37

Recommended Anchor Rod Hole and Washer Size

(Table 14-2 AISC Manual 15th Ed.)

Anchor Rod Diameter, in.	Hole Diameter, in.	Min. Washer Dimension, in.	Min. Washer Thickness, in.
3/4	1-5/16	2	1/4
7/8	1-9/16	2-1/2	5/16
1	1-7/8	3	3/8
1-1/4	2-1/8	3-1/2	1/2
1-1/2	2-3/8	4	1/2
1-3/4	2-7/8	4-1/2	5/8
2	3-1/4	5	3/4
2-1/2	3-3/4	5-1/2	7/8



38



Anchor Rod Details

- Use F1554 Gr 36 rods where possible and use larger rods rather than high strength rods
- Use symmetrical patterns if possible.
- Use heavy hex nuts top and bottom.
- Coordinate anchor rods and reinforcing steel locations (especially in piers & cols.).
- Do not use piers too short to develop anchor rods.



39

Anchor Rod Details

- Provide adequate grout thickness – 2”.
- Use setting nuts for lightly loaded columns.
- Use steel shims for heavy loaded columns.
- Consider setting plates where grouting may be difficult after setting the column.
- Consider epoxy anchors for fast track jobs and complex layouts.
- Consider construction sequencing when laying out patterns.



40

Anchor Rod Erection Requirements Per OSHA 1926.755

- Minimum of 4 anchor rods.
- Designed for a minimum load of 300 lbs at 18-inches eccentric from any column face
- Anchor rods shall not be repaired or replaced or field modified without the approval of SEOR.
- Approval must state if repair/modification shall require guying or bracing of the column.
- Contractor shall provide written notification to erector of any repair or modification.



41

Columns and Beams



42

Column not plumb per AISC COSP tolerances

Find out why it is out of plumb.

Solutions:

1. Remove or adjust beam connections.
2. Cut anchor rods, move column and replace anchor rods with epoxy rods.
3. Leave as is and brace the column.

Prevention:

1. Erector should check anchor rods and plumb in a timely manner.



43

After erection, beam line is too short (welded connections)

Weld shrinkage can cause shortening of approximately 1/8-inch in CJP welds.

Solution:

Cut loose several connections and correct by weld build out per AWS D1.1 requirements.

Prevention:

Provide adjustable erection connections and plan welding to compensate for shrinkage effects.



44



After erection, beam line is too short or too long (moment end plate connections)

Solution:

1. Too long - Remove beam and re-fabricate.
2. Too short - Provide finger shims as required.

Prevention:

Detail end plates short, approximately 1/8-in. each end, to allow for A6 and fabrication tolerances.



45

Camber



46



Members to camber

- Filler Beams
- Girder Beams
- Composite floor beams
- Trusses



47

Members not to camber

- Spandrel beams (those supporting facia materials).
- Continuous beams with cantilevers.
- Beams with moment connections or bracing connections.
- Members of non-uniform cross section.
- Beams with significant non-symmetrical loading.



48

Members not to camber

- Beams subject to torsional loads.
- Beams less than 25 ft. in length.
- Beams with web $\frac{1}{4}$ in. or less.
- Beams which require less than $\frac{3}{4}$ in. of camber.
- Crane runway girders.



49

Too much camber

Solutions:

1. Place concrete to constant elevation (Provide min. thickness / structural & fire rating?).
2. Remove camber (easy in the shop).
3. Replace the beam.

Prevention:

1. Check camber in the shop.
2. Specify camber based on concrete placement method.
 - Under camber for constant elevation.
 - Full camber for constant thickness.



50



Not enough camber

Solutions:

- Check design for additional concrete required for constant elevation concrete placement.
- Provide temporary shore to stop deflection at the level position for the beam.

Prevention:

- Check camber in shop.
- Design camber properly or use stiffer beams.



51

Camber Cautions

- Reduce camber for beams at columns lines because of added connection restraint.
- Be careful of camber differences between beams and joists.
- Be careful of cambered beams or joists adjacent to non-cambered moment frames braced frames or walls.



52



Camber Tolerances

From the AISC Code of Standard Practice Section 6.4.4:

- For beams greater than 50 feet in length, the camber tolerance is minus zero/plus 1/2 in. with an additional 1/8 in. per each additional 10 foot of length (or fraction thereof) beyond 50 feet.
- The AISC Code of Standard Practice specifies that camber is measured in the un-stressed position in the shop.



53

Shear Studs



54



Shear studs break off during inspection

Solutions:

1. Inspect and replace.
2. Fillet weld studs (only if a few are req'd).

Prevention:

1. Install studs properly.
2. See AWS Section 7.6 for Qualification Requirements.



55

Studs are too high

Solutions:

1. Remove studs and replace.
2. Use additional concrete thickness.
3. Reduce beam camber by heat straightening.

Prevention:

1. Specify camber properly or not at all.
2. Don't use composite beams.
3. Design with some added capacity.



56

Problems with fit-up of weak-axis moment connections

- Moment connection to column web with misalignment between continuity plate and beam flange. This usually occurs when the continuity plate is the same thickness as the beam flange.



57

Misalignment between continuity plate and beam flange

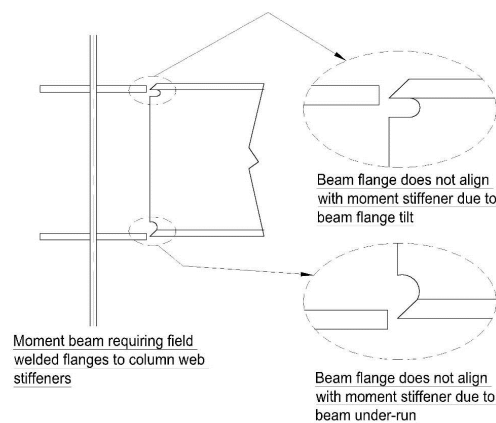

58

Misalignment between continuity plate and beam flange – Prevention

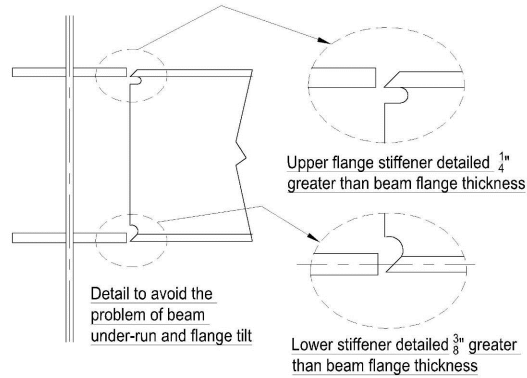

59

Bolted Flange Plate Connections



60



A6 Tolerances

Table 1-22
ASTM A6 Tolerances for W-Shapes
and HP-Shapes

Permissible Cross-Sectional Variations

Nominal Depth, in.	A Depth at Web Centerline, in.		B Flange Width, in.		T + T' Flanges Out of Square, Max. in.	E ^a Web Off Center, in.	C, Max. Depth at any Cross-Section over Theoretical Depth, in.
	Over	Under	Over	Under			
To 12, incl.	1/8	1/8	1/4	3/16	1/4	3/16	1/4
Over 12	1/8	1/8	1/4	3/16	5/16	3/16	1/4

Bolted Flange Plate Connections

Solutions:

1. Jack plates against beam by snugging bolts, then tensioning.
2. Use shims.
3. If beam does not fit between plates, remove top plate and re-weld.

Prevention:

1. Provide shim space, check A6 tolerances.
2. Modify weld detail and weld sequence to reduce out of plane distortion.
3. Heat straighten as required after welding.



Interference

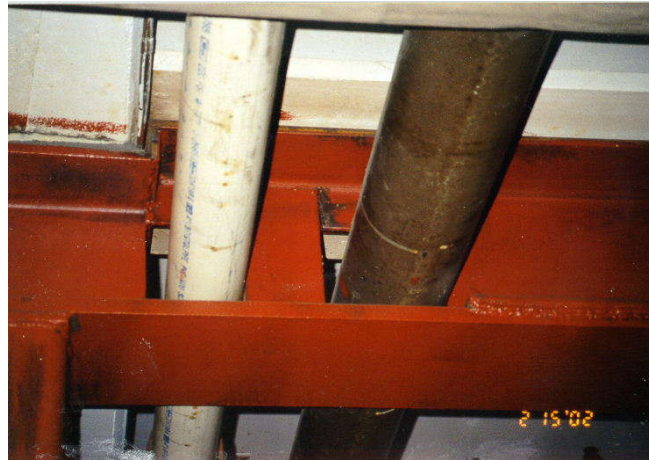

63

Interference Problems



64



Pipe Interference



65

Pipe Interference



66



Bracing Interference



67

Connections



68



Reinforcing Connections

Solutions:

1. Remove and replace the connection with a stronger connection.
2. Use "X" Type Bolts.
3. Add weld length or increase weld size.
4. Remove old rivets or A307 bolts and replace with A325 or A490 bolts.
5. Ream holes and use larger diameter bolts.
6. Add web framing angles to a seated connection.
7. Add a seat to a web framed connection.



69

Reinforcing Connections

Solutions:

1. Add weld to existing riveted or A307 bolted connections. (see AISC J1.9)
2. Add weld to existing high strength bolted connections. (see AISC J1.8 and J1.9)
3. Extend the length of framing angles by welding additional length.
4. Add a second angle to a single angle web framed connection.



70



Fit-up Problems



71

Bolts don't fit in holes- Shear Connections

- For new design, the AISC Specification in Section J1.8 permits load sharing between welds and bolts when four conditions are met. See J1.8 for details.
- For welded **alterations** to structures with existing rivets or bolts Section J1.9 also permits load sharing when certain conditions are met. One of which is that the weld available strength must not be less than 25% of the required strength of the connection.



72



Gusset plate holes in wrong location



73

Bolts don't fit in holes



74



Bolts don't fit in holes

Solutions:

1. Ream holes.
2. Field weld.
3. Fill and drill.
4. Replace the connection material.

Prevention:

1. Proper detailing and fabrication.
2. Design using SC bolts, and oversize holes.



75

Bolt holes have insufficient edge distance

Solutions:

1. Perform an analysis to see if the insufficient edge distance is detrimental to the safety of the joint.
2. Add material to increase the edge distance.

Prevention:

1. Do not design connections with minimum edge distances too tight. To keep out of trouble always add an extra 1/8 inch to edge distances.



76



Member Selection Guidelines



77

Member Selection Guidelines

- W12 min. depth for floor framing (use W14 if supporting girder requires large cope).
- Avoid beams with 4-inch flanges at:
 - Spandrel beams with adjustable edge form.
 - Beams requiring bolted flange connections.
 - Beams with double joist bearing. Locations where joists frame from each side.
- Composite beams:
 - Limit deflection to avoid large cambers.
 - Use minimum % of composite to limit studs.
 - Avoid studs on infill beams parallel to deck ribs.



78



Shear Connection Guidelines

- Show Reactions on framing plans.
- Use AISC Standard Details
 - Dbl Angle - bolted/bolted or bolted/welded.
 - Single Angle - for beam to beam.
 - Single Plate - for beam to beam & skewed.
 - End Plate - heavy skewed connections.
- Show special connections.



79

Moment Connection Guidelines

- Provide actual moment envelope.
- Design considerations:
 - End plates may be limited by bolts or column flange bending capacity.
 - CJP welds are a “no brainer” but generally more expensive.
 - Top and bottom bolted plates are an option if less than M_p required.
- Size column to avoid reinforcement.



80



Cantilever Design Guidelines

- Provide actual moment and shear forces.
- Indicate if camber is required.
- Use end plate connections where possible for erection ease and safety.
- Shop weld short cantilevers where possible.
- Consider making the beam continuous and stacking columns on long cantilevers.



81

Bracing Connection Guidelines

- Show all forces for complete load path and try to provide equilibrium condition at joint.
- Transfer forces should include all drag strut forces and diaphragm connection details.
- Consider modifying work points for extreme connection geometry.
- Allow oversize holes and field welding where required for constructability.



82



Classic Overhead Crane Building



83



84









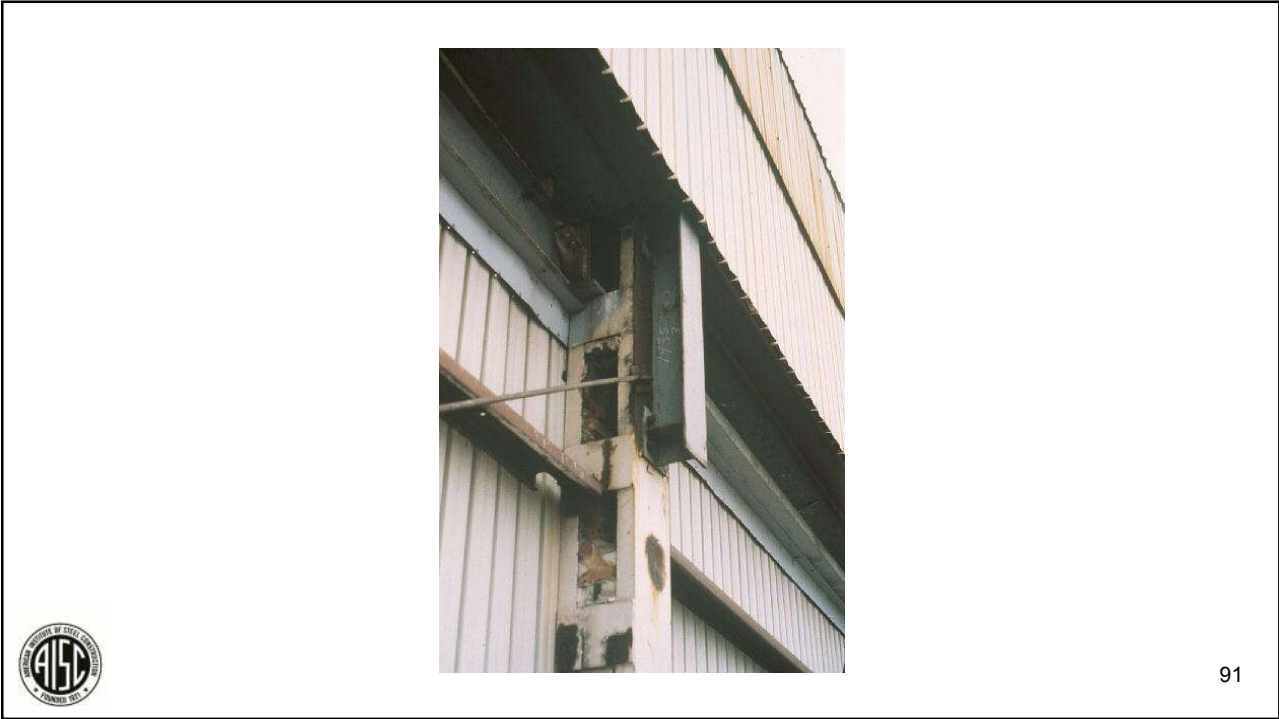

Contributors

- Larry Kloiber, LeJeune Steel
- Tom Ferrell, Ferrell Engineering
- AISC Solutions Center



AISC | Questions?



CEU / PDH Certificates

- You will receive an email on how to report attendance from:
registration@aisc.org.
- Be on the lookout: Check your spam filter! Check your junk folder!
- Completely fill out online form. Don't forget to check the boxes next to each attendee's name!



CEU / PDH Certificates

- Reporting site (URL will be provided in the forthcoming email).
- Username: Same as AISC website username.
- Password: Same as AISC website password.





AISC | Thank you

