

## AISC Live Webinars

Getting the Welds You Need  
July 30, 2020



## AISC Live Webinars

### Welcome to today's webinar!

Today's audio is being broadcast through the internet. Please be sure to turn up the volume on your speakers.

Please type any questions or comments in the Q&A window.



## AISC Live Webinars

### AIA Credit

AISC is a Registered Provider with The American Institute of Architects Continuing Education Systems (AIA/CES). Credit(s) earned on completion of this program will be reported to AIA/CES for AIA members. Certificates of Completion for both AIA members and non-AIA members are available upon request.

This program is registered with AIA/CES for continuing professional education. As such, it does not include content that may be deemed or construed to be an approval or endorsement by the AIA of any material of construction or any method or manner of handling, using, distributing, or dealing in any material or product.

Questions related to specific materials, methods, and services will be addressed at the conclusion of this presentation.



## AISC Live Webinars

### Copyright Materials

This presentation is protected by US and International Copyright laws. Reproduction, distribution, display and use of the presentation without written permission of AISC is prohibited.

© The American Institute of Steel Construction 2020

The information presented herein is based on recognized engineering principles and is for general information only. While it is believed to be accurate, this information should not be applied to any specific application without competent professional examination and verification by a licensed professional engineer. Anyone making use of this information assumes all liability arising from such use.



## AISC Live Webinars

### Course Description

Getting the Welds You Need  
July 30, 2020

Many are familiar with welded structural connections but struggle to accurately convey design details and to ensure mechanical properties and quality are achieved. This webinar will provide guidance regarding welding symbols; joint details; document submittals; welding procedure specification (WPS) review; and inspection and nondestructive testing, following the requirements of AISC 360, AISC 341, AWS D1.1 and AWS D1.8.



## AISC Live Webinars

### Learning Objectives

- Explain how to properly communicate welded joint requirements on contract documents.
- List parameters required to be provided in a weld procedure specification.
- Explain how to properly specify inspection and testing requirements using AISC and AWS requirements.
- List nondestructive testing methods and identify what discontinuities each might detect.



Getting the Welds You Need

## Getting the Welds You Need



Robert E. Shaw, Jr., PE  
President  
Steel Structures Technology Center, Inc.  
Howell, Michigan



Getting the Welds You Need



### Robert E. Shaw, Jr., PE

AISC Specifications Committee, TC12, TC6 (past member)  
AISC Connections Prequalification Review Panel  
AWS D1 Committee, D1.1, D1.8  
International Institute of Welding  
Commission XVIII on Quality Management, Chair  
Commission XV on Design, Analysis and Fabrication of Welded Structures, Past Chair  
ISO TC167/WG3, ISO/XX 17607 Steel Structures  
RCSC Specifications Committee  
ASTM F16 Fasteners Committee

### Steel Structures Technology Center, Inc.

5277 Leelanau Ct.  
Howell, MI 48843-5437  
(734) 878-9560

[www.steelstructures.com](http://www.steelstructures.com)



2

Getting the Welds You Need

Many are familiar with welded structural connections but may struggle with accurately conveying design details and ensuring that mechanical properties and quality are achieved. This webinar will provide guidance regarding

- welding symbols,
- joint details,
- document submittals,
- welding procedure specification (WPS) review, and
- inspection and nondestructive testing, following the requirements of AISC 360, AISC 341, AWS D1.1 and AWS D1.8.



3

Getting the Welds You Need

- **welding symbols**
- **joint details**
- **document submittals**
- **welding procedure specification (WPS) review**
- **inspection**
- **nondestructive testing**



4

Getting the Welds You Need

**AWS D1.1/D1.1M:2020**  
[www.aws.org](http://www.aws.org)



**AISC 360-16**  
[www.aisc.org](http://www.aisc.org)



5

Getting the Welds You Need

**AWS D1.8/D1.8M:2016**



**AISC 341-16**



6

Getting the Welds You Need

**A GENERAL PROVISIONS**  
**A4 STRUCTURAL DESIGN DRAWINGS AND SPECIFICATIONS**

The structural design drawings and specifications shall meet the requirements of the *Code of Standard Practice*.

**User Note:**  
Provisions in this Specification contain information that is to be shown on design drawings. These include:

- Section A3.1c: Rolled heavy shapes where alternate core Charpy V-notch toughness (CVN) is required
- Section A3.1d: Built-up heavy shapes where CVN toughness is required

Other information needed by the fabricator or erector should be shown on design drawings, including:

- Fatigue details requiring nondestructive testing
- Risk category (Chapter N)
- Indication of complete-joint-penetration (CJP) groove welds subject to tension (Chapter N)

7

Getting the Welds You Need

**3 DESIGN DOCUMENTS AND SPECIFICATIONS**  
**3.1 Structural Design Documents and Specifications**

*Commentary:*  
...  
However, critical requirements that are necessary to protect the owner's interest, that affect the integrity of the structure or that are necessary for the fabricator and the erector to proceed with their work must be included in the contract documents.

Some examples of critical information may include, when applicable:

- Special material requirements to be reported on the material test reports.
- Welded-joint configuration.
- Weld-procedure qualification.
- Final disposition of backing and runoff tabs.
- Shop and field inspection requirements.
- Nondestructive testing requirements, including acceptance criteria.

8



Getting the Welds You Need

1 General Requirements  
1.5 Responsibilities  
1.5.1 Engineer's Responsibilities

The **Engineer** shall be responsible for the development of the contract documents that govern products or structural assemblies produced under this code.

The **Engineer** may add to, delete from, or otherwise modify, the requirements of this code to meet the particular requirements of a specific structure.

All requirements that modify this code shall be incorporated into contract documents.

The **Engineer** shall determine the suitability of all joint details to be used in a welded assembly.



Structural Welding Code—  
Steel 2020

9

Getting the Welds You Need

1 General Requirements  
1.5 Responsibilities  
1.5.1 Engineer's Responsibilities

The **Engineer** shall specify in contract documents, as necessary, and as applicable, the following:

- (1) Code requirements that are applicable only when specified by the Engineer.
- (2) All additional NDT that is not specifically addressed in the code.
- (3) Extent of verification inspection, when required.
- (4) Weld acceptance criteria other than that specified in Clause 8.
- (5) CVN toughness criteria for weld metal, base metal, and/or HAZ when required.
- (6) For nontubular applications, whether the structure is statically or cyclically loaded.
- (7) Which welded joints are loaded in tension.
- (8) All additional requirements that are not specifically addressed in the code.
- (9) For OEM applications, the responsibilities of the parties involved.



Structural Welding Code—  
Steel 2020

10

Getting the Welds You Need

4 Design of Welded Connections  
Part A Common Requirements for Design of Welded Connections  
(Nontubular and Tubular Members)  
4.3 Contract Plans and Specifications  
4.3.1 Plan and Drawing Information

Complete information regarding base metal specification designation (...) and location, type, size, and extent of all welds shall be clearly shown on the contract plans and specifications, hereinafter referred to as the contract documents.

If the **Engineer** requires specific welds to be performed in the field, they shall be designated in the contract documents.



Structural Welding Code—  
Steel 2020

11

Getting the Welds You Need

4 Design of Welded Connections  
Part A Common Requirements for Design of Welded Connections  
(Nontubular and Tubular Members)  
4.3 Contract Plans and Specifications  
4.3.2 Notch Toughness Requirements

If notch toughness of welded joints is required, the **Engineer** shall specify the minimum absorbed energy with the corresponding test temperature for the filler metal classification to be used, or the **Engineer** shall specify that the WPSs be qualified with CVN tests.

If WPSs with CVN tests are required, the **Engineer** shall specify the minimum absorbed energy, the test temperature and whether the required CVN test performance is to be in the weld metal, or both in the weld metal and the HAZ (...).



Structural Welding Code—  
Steel 2020

12



Getting the Welds You Need

4 Design of Welded Connections  
Part A Common Requirements for Design of Welded Connections  
(Nontubular and Tubular Members)  
4.3 Contract Plans and Specifications  
4.3.3 Specific Welding Requirements

The **Engineer**, in the contract documents, and the **Contractor**, in the shop drawings, shall indicate those joints or groups of joints in which the **Engineer** or Contractor require a specific assembly order, welding sequence, welding technique or other special precautions. ...

Structural Welding Code—Steel 2020



13

Getting the Welds You Need

4 Design of Welded Connections  
Part C Specific Requirements for Design of Nontubular Connections  
(Cyclically Loaded)  
4.13.3 Engineer's Responsibility

The **Engineer** shall provide either complete details, including weld sizes, or shall specify the planned cycle life and the maximum range of moments, shears, and reactions for the connections in contract documents.

Structural Welding Code—Steel 2020



14

Getting the Welds You Need

1 General Requirements  
1.7 Mandatory and Nonmandatory Provisions  
1.7.1 Code Terms "Shall," "Should," and "May"  
1.7.1.1 Shall

Code provisions that use "**shall**" are mandatory unless specifically modified in contract documents by the **Engineer**.

Structural Welding Code—Steel 2020



15

Getting the Welds You Need

1 General Requirements  
1.7 Mandatory and Nonmandatory Provisions  
1.7.1 Code Terms "Shall," "Should," and "May"  
1.7.1.2 Should

The word "**should**" is used to recommend practices that are considered beneficial, but **are not requirements**.

Structural Welding Code—Steel 2020



16



Getting the Welds You Need

Structural Welding Code—Steel 2020

**1 General Requirements**  
**1.7 Mandatory and Nonmandatory Provisions**  
**1.7.1 Code Terms "Shall," "Should," and "May"**  
**1.7.1.3 May**

The word "may" in a provision allows the use of optional procedures or practices that can be used as an alternative or supplement to code requirements.

Those optional procedures that require the Engineer's approval shall either be specified in the contract documents, or require the Engineer's approval.

The Contractor may use any option without the Engineer's approval when the code does not specify that the Engineer's approval shall be required.



17

Getting the Welds You Need

Structural Welding Code—Steel 2020

**11 Strengthening and Repair of Existing Structures**  
**11.1 Scope**  
Strengthening or repairing an existing structure shall consist of modifications to meet design requirements specified by the Engineer. ...

**11.2 General**  
The Engineer shall prepare a comprehensive plan for the work.

Such plans shall include, but are not limited to, design, workmanship, inspection and documentation.

...



18

Getting the Welds You Need

Seismic Provisions for Structural Steel Buildings

**A GENERAL REQUIREMENTS**  
**A4 STRUCTURAL DESIGN DRAWINGS AND SPECIFICATIONS**  
**A4.1 General**

Structural design drawings and specifications shall indicate the work to be performed, and include items required by the *Specification*, the *AISC Code of Standard Practice for Steel Buildings and Bridges*, the applicable building code, and the following, as applicable:

- (a) Designation of the SFRS
- (b) Identification of the members and connections that are part of the SFRS
- (c) Locations and dimensions of protected zones
- (d) Connection details between concrete floor diaphragms and the structural steel elements of the SFRS
- (e) Shop drawing and erection drawing requirements not addressed in Section I1



19

Getting the Welds You Need

Seismic Provisions for Structural Steel Buildings

**A GENERAL REQUIREMENTS**  
**A4 STRUCTURAL DESIGN DRAWINGS AND SPECIFICATIONS**  
**A4.2 Steel Construction**

In addition to the requirements of Section A4.1, structural design drawings and specifications for steel construction shall indicate the following items, as applicable:

- (a) Configuration of the connections
- (b) Connection material specifications and sizes
- (c) Locations of demand critical welds
- (d) Locations where gusset plates are to be detailed to accommodate inelastic rotation
- (e) Locations of connection plates requiring Charpy V-notch toughness in accordance with Section A3.3(b)
- (f) Lowest anticipated service temperature of the steel structure, if the structure is not enclosed and maintained at a temperature of 50°F (10°C) or higher



20



Getting the Welds You Need

**A GENERAL REQUIREMENTS**

**A4 STRUCTURAL DESIGN DRAWINGS AND SPECIFICATIONS**

**A4.2 Steel Construction**

...

- (g) Locations where weld backing is required to be removed
- (h) Locations where fillet welds are required when weld backing is permitted to remain
- (i) Locations where fillet welds are required to reinforce groove welds or to improve connection geometry
- (j) Locations where weld tabs are required to be removed
- (k) Splice locations where tapered transitions are required
- (l) The shape of weld access holes, if a shape other than those provided for in the *Specification* is required
- (m) Joints or groups of joints in which a specific assembly order, welding sequence, welding technique, or other special precautions are required, where such items are designated to be submitted to the engineer of record



21

Seismic Provisions for Structural Steel Buildings

Getting the Welds You Need

**1 General Requirements**

**1.4 Responsibilities**

**1.4.1 Engineer's Responsibilities**



Structural Welding Code—  
Seismic Supplement 2016

In addition to the items listed in AWS D1.1/D1.1M, the Engineer shall provide the following information in the Contract Documents:

- (1) Connection configuration, material specifications, and part sizes required to provide the needed seismic performance (see 1.5)
- (2) Identification of members that comprise the Seismic Force Resisting System (SFERS) and that are subject to the provisions of this code (see Clause 3)
- (3) The location of the Protected Zone for members of the SFERS (see Clause 3)



22

Getting the Welds You Need

**1 General Requirements**

**1.4 Responsibilities**

**1.4.1 Engineer's Responsibilities**



Structural Welding Code—  
Seismic Supplement 2016

In addition to the items listed in AWS D1.1/D1.1M, the Engineer shall provide the following information in the Contract Documents:

- (4) Welds designated as “Demand Critical” and subject to specific provisions of this code (see Clause 3)

**AWS D1.8/D1.8M:2016 Commentary**  
*Figures C-1.1, 1.2 and 1.3 — Example ...C-Demand Critical Welds*

*AISC 341-16, Commentary A3.4, pg 9.1-166*  
*Demand critical welds are generally complete-joint-penetration groove (CJP) welds so designated because they are subjected to yield level or higher stress demand and located in a joint whose failure would result in significant degradation in the strength or stiffness of the SFERS.*



23

Getting the Welds You Need

**1 General Requirements**

**1.4 Responsibilities**

**1.4.1 Engineer's Responsibilities**



Structural Welding Code—  
Seismic Supplement 2016

In addition to the items listed in AWS D1.1/D1.1M, the Engineer shall provide the following information in the Contract Documents:

- (5) Locations where the removal of backing is required (see 6.13)
- (6) Locations where fillet welds are required when backing is permitted to remain (see 6.15)
- (7) Locations where the removal of weld tabs is required (see 6.16.3 and 6.16.4)
- (8) Locations where fillet welds are required to reinforce groove welds, or to improve connection geometry (see 6.14)



24



Getting the Welds You Need

**1 General Requirements**  
**1.4 Responsibilities**  
**1.4.1 Engineer's Responsibilities**

Structural Welding Code—  
Seismic Supplement 2016

In addition to the items listed in AWS D1.1/D1.1M, the Engineer shall provide the following information in the Contract Documents:

(9) Locations of access holes and the required shape, whether standard AWS D1.1/D1.1M geometry (see 6.11.1.1), standard alternate geometry (see 6.11.1.2), or a special geometry designated by the Engineer (see 6.11.1.3)



25

Getting the Welds You Need

**1 General Requirements**  
**1.4 Responsibilities**  
**1.4.1 Engineer's Responsibilities**

Structural Welding Code—  
Seismic Supplement 2016

In addition to the items listed in AWS D1.1/D1.1M, the Engineer shall provide the following information in the Contract Documents:

(10) The Lowest Anticipated Service Temperature (LAST) of the steel structure for structures that are not normally enclosed and maintained at a temperature of 50°F [10°C] or higher (see Clause 3 and 6.2.2)

*lowest anticipated service temperature (LAST). The lowest one (1) hour average temperature with a 100-year mean recurrence interval.*

**AISC 341-16, Lowest anticipated service temperature (LAST).** Lowest daily minimum temperature, or other suitable temperature, as established by the engineer of record.

**Commentary A3.4, pg 9.1-167** – For purposes of the Provisions, the LAST may be considered to be the lowest one-day mean temperature (LODMT) compiled from National Oceanic and Atmospheric Administration (NOAA) data.



26

Getting the Welds You Need

**1 General Requirements**  
**1.4 Responsibilities**  
**1.4.1 Engineer's Responsibilities**

Structural Welding Code—  
Seismic Supplement 2016

In addition to the items listed in AWS D1.1/D1.1M, the Engineer shall provide the following information in the Contract Documents:

(11) Butt joints subject to tension where tapered transitions are required (see 4.2)

(12) Those joints or groups of joints in which a specific assembly order, welding sequence, welding technique, or other special precautions are required (see AWS D1.1/D1.1M subclauses 2.3.3 and 5.20)

(13) Quality Assurance Plan (QAP) for the project (see Clause 3 and 7.1)

(14) Any additional provisions applicable to the specific project not governed by AWS D1.1/D1.1M or this code.



27

Getting the Welds You Need

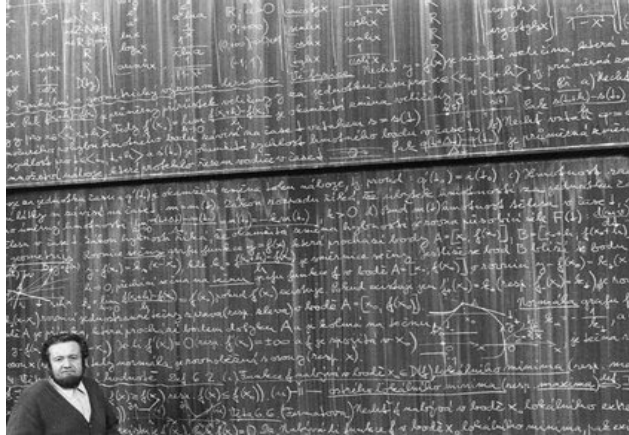

28

Getting the Welds You Need

- **welding symbols**
- **joint details**
- **document submittals**
- **welding procedure specification (WPS) review**
- **inspection**
- **nondestructive testing**





29

Getting the Welds You Need

AWS A2.4:2020

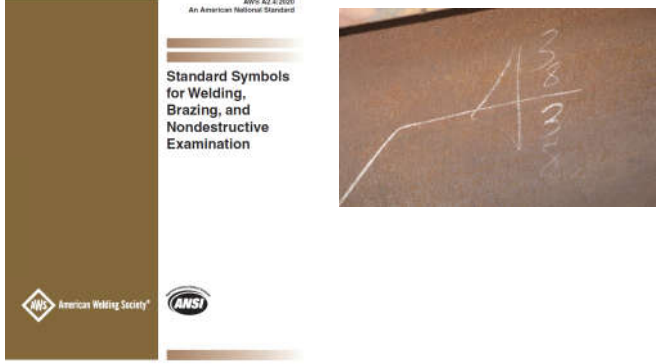
Standard Symbols for Welding, Brazing, and Nondestructive Examination





30

Getting the Welds You Need

2020 Standard Symbols

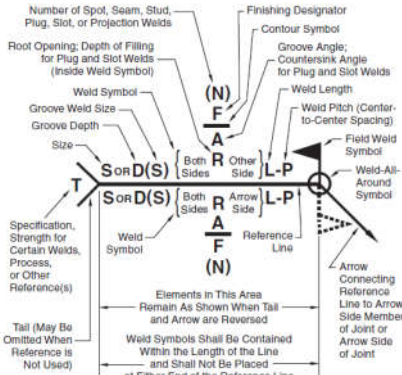
- **Figure 4.3 Standard Location of the Elements of a Welding Symbol**
- **Annex E (Informative) Welding Symbol Chart**

31

Getting the Welds You Need

2020 Standard Symbols

Figure 4.1 Weld Symbols

GROOVE							
SQUARE	V	BEVEL	U	J	FLARE-V	FLARE-BEVEL	SCARF*
FILLET	PLUG OR SLOT	STUD	SPOT OR PROJECTION	SEAM	BACK OR BACKING	SURFACING	EDGE



32

Getting the Welds You Need

2020  
Standard Symbols

Figure 4.2 Supplementary Symbols

WELD-ALL-AROUND	FIELD WELD	MELT-THROUGH	CONSUMABLE INSERT (SQUARE)	BACKING (RECTANGLE)	SPACER (RECTANGLE)	CONTOUR		
						FLUSH OR FLAT	CONVEX	CONCAVE



Getting the Welds You Need

Table 8-2 (continued)  
Prequalified Welded Joints

Basic Weld Symbols									
Back	Fillet	Plug or Slot	Groove or Butt						Flare Bevel
			Square	V	Bevel	U	J	Flare V	
Supplementary Weld Symbols									
Backing	Spacer	Weld All Around	Field Weld	Contour		For other basic and supplementary weld symbols, see AWS A2.4 (2007).			
				Flush	Convex				



Getting the Welds You Need

Table 8-2 (continued) Prequalified Welded Joints									
Basic Weld Symbols									
Back	Fillet	Square	V	Bevel	U	J	Flare V	Flare Bevel	
									Plug or Slot
						For other basic and supplementary weld symbols, see AWS A2.4 (2007).			

**Note:**  
Size, weld symbol, length of weld, and spacing must read in that order, from left to right, along the reference line. Neither orientation of reference nor location of the arrow alters this rule.  
The perpendicular leg of  $\Delta$ ,  $V$ ,  $U$ ,  $J$ , weld symbols must be at left.  
Dimensions of fillet welds must be shown on both the arrow side and the other side.  
Symbols apply between abrupt changes in direction of welding unless governed by the "all around" symbol or otherwise dimensioned.  
These symbols do not explicitly provide for the case that frequently occurs in structural work, where duplicate material (such as stiffeners) occurs on the far side of a web or gusset plate. The fabricating industry has adopted this convention: that when the billing of the detail material discloses the existence of a member on the far side as well as on the near side, the welding shown for the near side shall be duplicated on the far side.



Getting the Welds You Need

Standard Location of Elements of a Welding Symbol

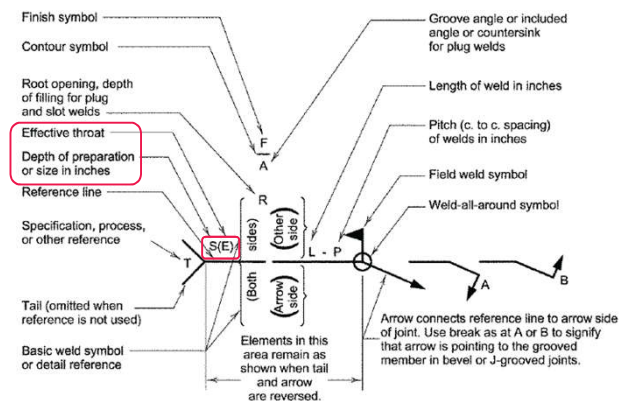

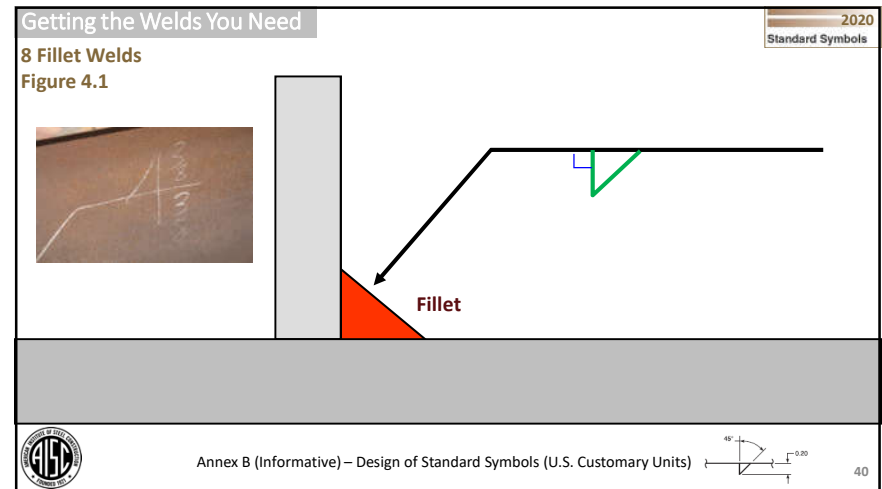
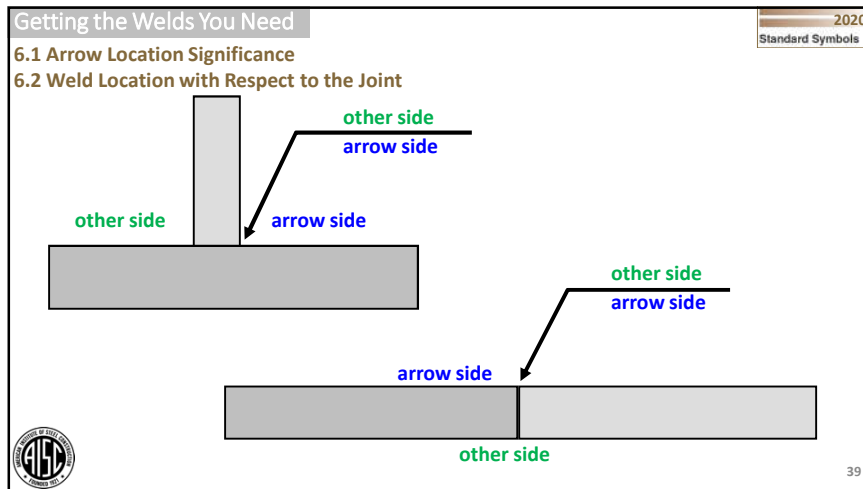
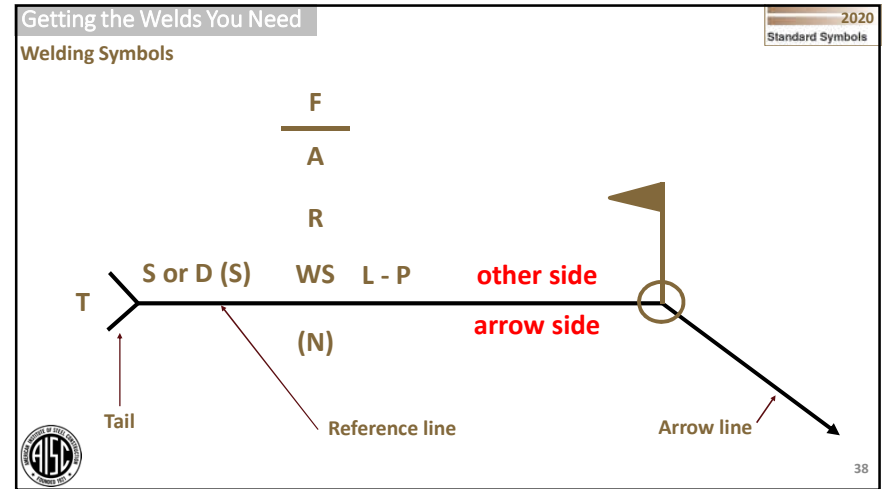
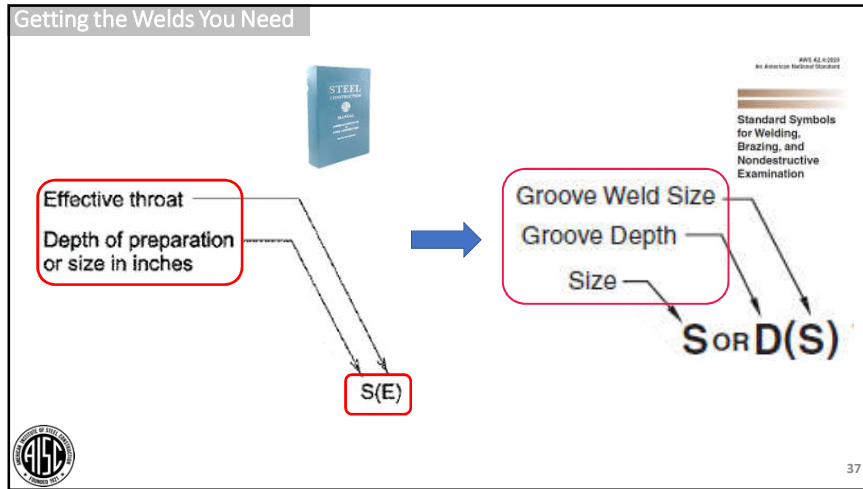

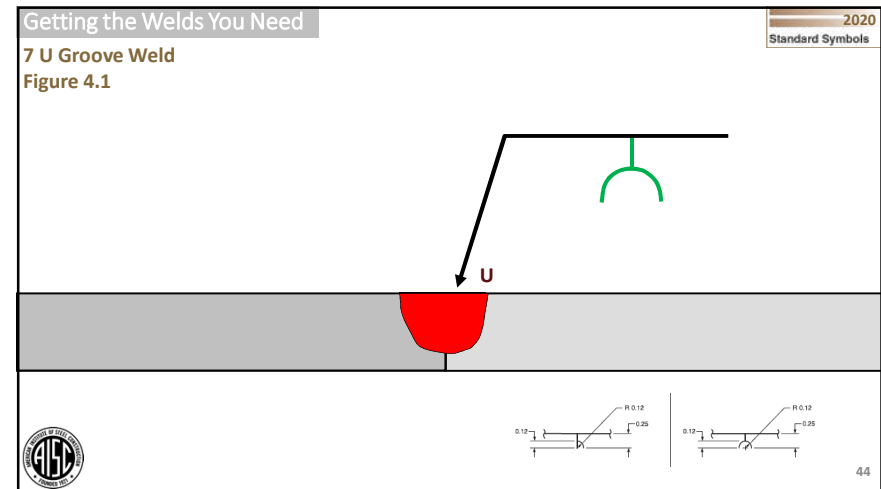
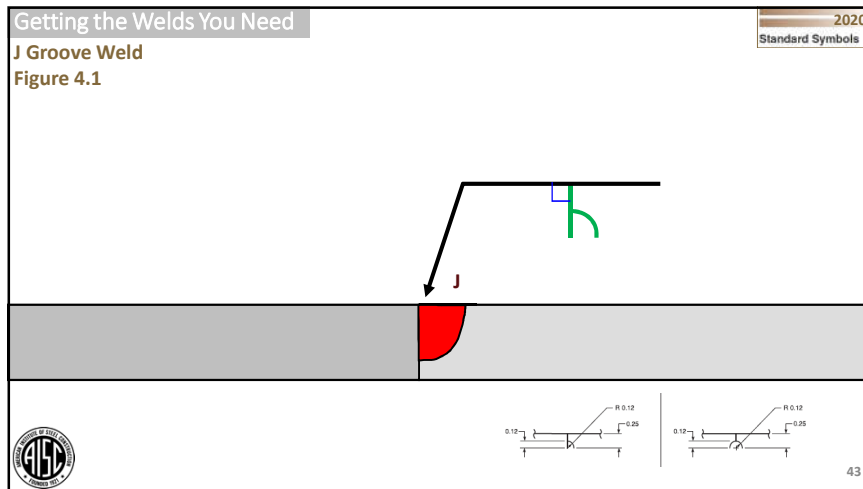
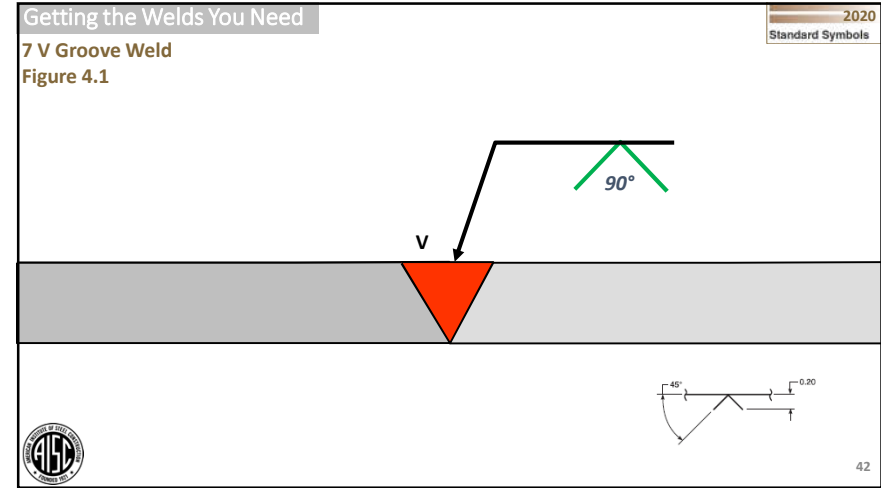
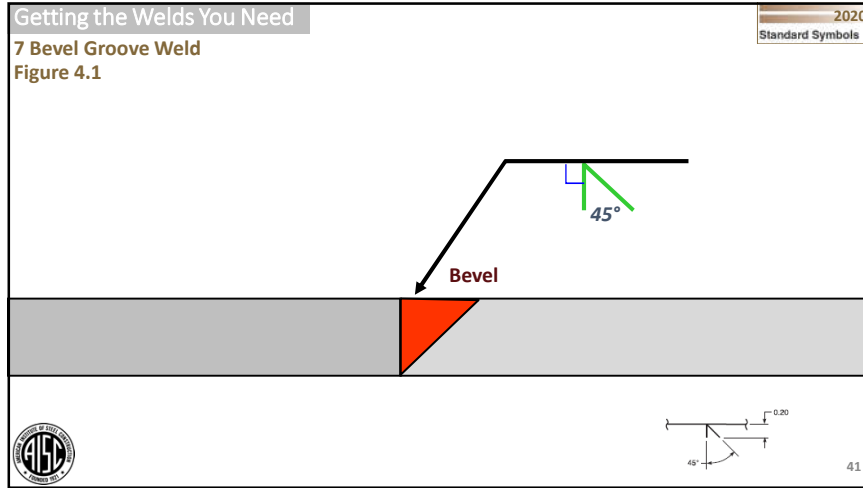

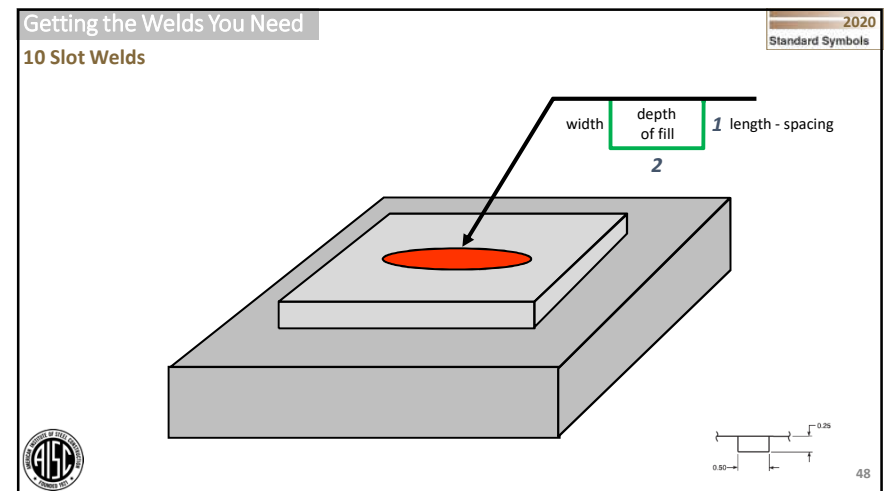
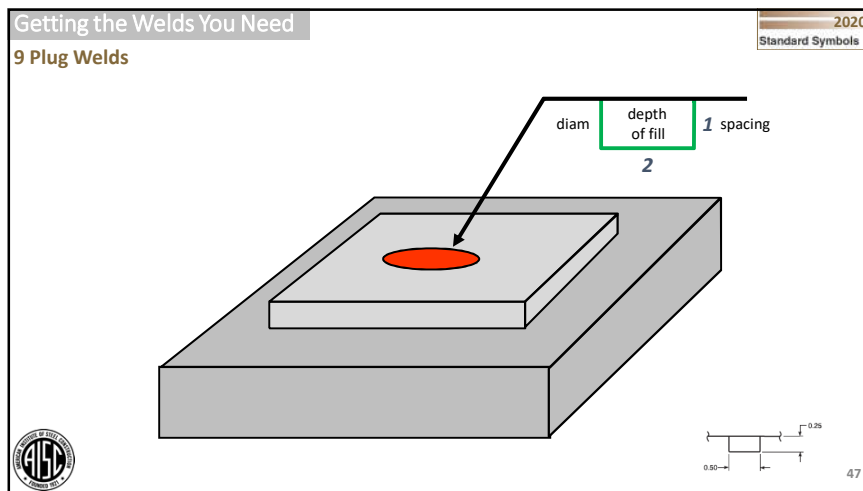
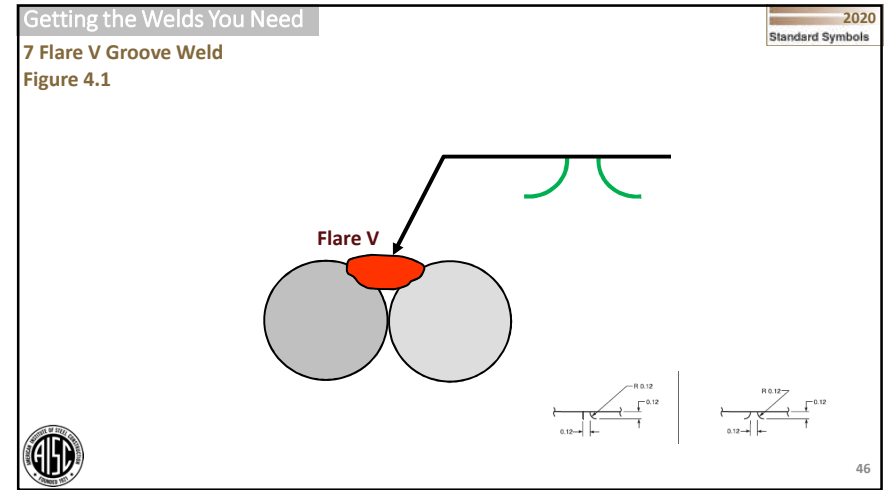
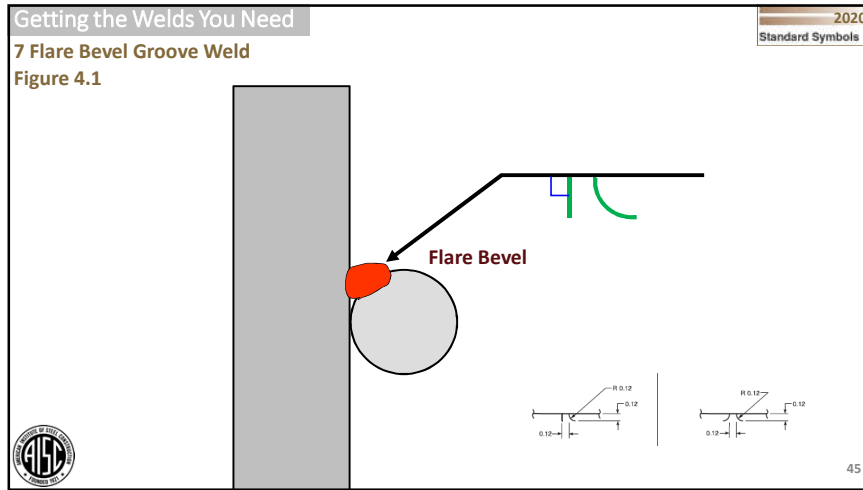

Getting the Welds You Need 2020  
Standard Symbols

**14 Stud Welds**

diam spacing  
(number)

49

Getting the Welds You Need 2020  
Standard Symbols

**6.9 Field Weld Symbol**

6.9 Field Weld Symbol. A flag is used to specify a field weld. The flag shall be placed at a right angle to, and on either side of, the reference line at the junction with the arrow (see Annex Fig. 2). The flag may point in either direction.

50

Getting the Welds You Need 2020  
Standard Symbols

**6.11 Weld All Around Symbol**

51

Getting the Welds You Need 2020  
Standard Symbols

**Weld All Around**

BASE PLATE SEE SCHEDULE  
 OPTIONAL 2" DIA GROUT HOLE  
 TYP. COLUMN PLAN

BASE P. SEE SCHED.  
 HSS COL. & BASE PL, TYP.  
 HSS COLUMN PLAN

52



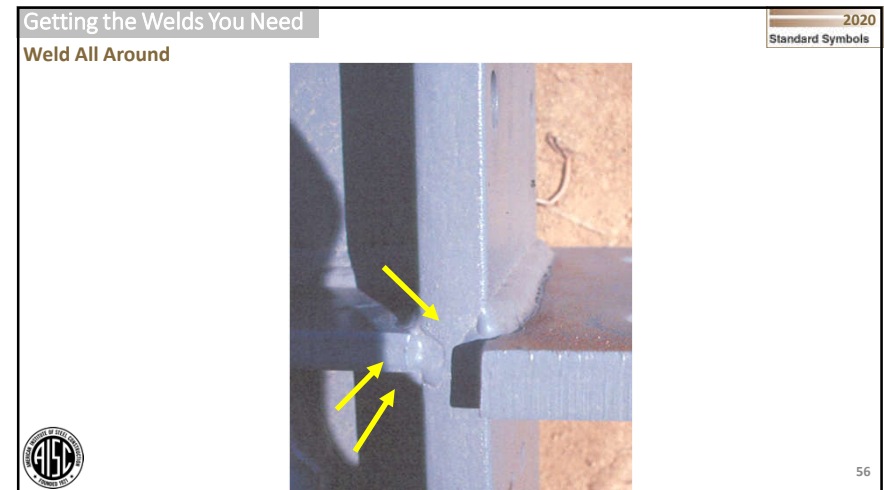
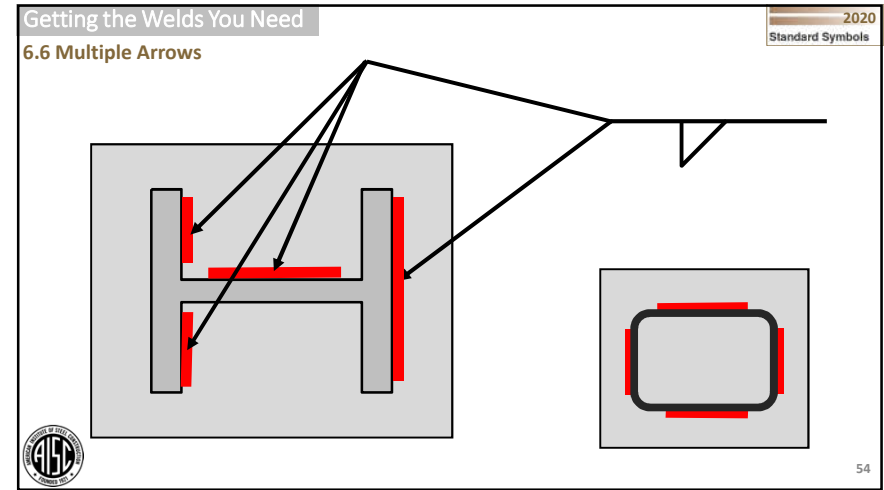
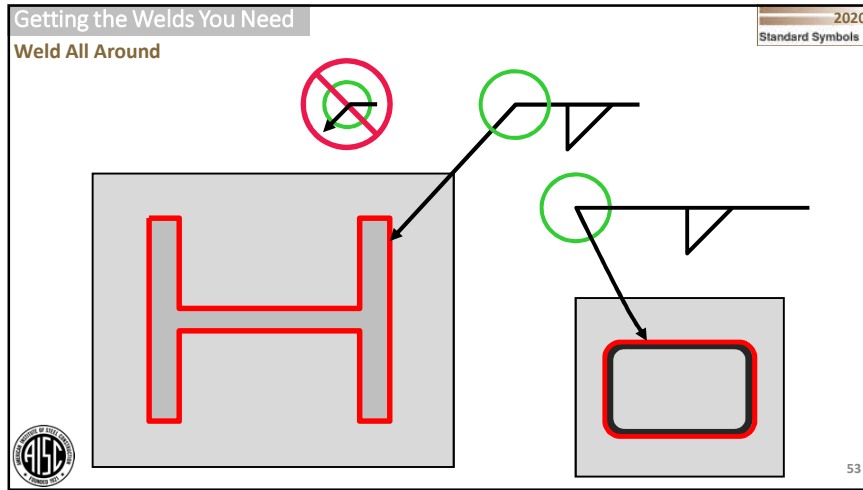

Getting the Welds You Need 2020  
Standard Symbols

7.8 Joints with Backing

backing

spacer

2

R

1

0.40

0.20

0.20

0.12

0.40

45°

57

Getting the Welds You Need 2020  
Standard Symbols

7.7 Back and Backing Welds

backgouge

3

1

2

1

2

0.30

0.10

NOTE: MELTHROUGH BACK WELD AND BACKING WELD SYMBOL HAVE THE SAME DIMENSIONS

58

Getting the Welds You Need 2020  
Standard Symbols

7.7 Back and Backing Welds

backgouge

3

1

2

1

2

59

Getting the Welds You Need 2020  
Standard Symbols

6.7 Multiple Reference Lines

6.7.1 Sequence of Operations

backgouge

3

1

2

1

2

60



Getting the Welds You Need

2020  
Standard Symbols

6.7 Multiple Reference Lines  
 6.7.1 Sequence of Operations

backgouge

61

Getting the Welds You Need

2020  
Standard Symbols

8.4.3 Chain Intermittent Fillet Welds  
 Figure 8.2 (B)

Length - Spacing c/c

3 - 12  
3 - 12

62

Getting the Welds You Need

2020  
Standard Symbols

8.4 Intermittent Fillet Welds  
 Figure 8.2 (B)

Length - Spacing c/c

3 - 12

63

Getting the Welds You Need

2020  
Standard Symbols

8.4.4 Staggered Intermittent Fillet Welds  
 Figure 8.2 (C)

Length - Spacing c/c

3 - 12  
3 - 12

8.4.4 Staggered Intermittent Fillet Welds. The dimensions of staggered intermittent fillet welds shall be specified on both sides of the reference line, and the fillet weld symbols shall be offset on opposite sides of the reference line. The segments of staggered intermittent fillet welds shall be symmetrically spaced on both sides of the joint [see Figure 8.2(C)].

64



Getting the Welds You Need 2020  
Standard Symbols

8.2 Fillet Weld Size  
 8.3 Fillet Weld Length

1/4  
size

6  
length

Groove Weld Size  
 Groove Depth  
 S D(S)

65

Getting the Welds You Need 2020  
Standard Symbols

7.2 Groove Depth and Groove Weld Size

size

depth of groove

3/4 (5/8)

groove depth  
 (formerly "depth of preparation")

Groove weld size  
 (formerly "effective throat")

Groove Weld Size  
 Groove Depth  
 S D(S)

66

Getting the Welds You Need 2020  
Standard Symbols

7.3 Groove Dimensions  
 Figure 7.10 ... Root Opening ...  
 Figure 7.11 ... Groove Angle ...

root opening

groove angle

1/4  
45°

67

Getting the Welds You Need 2020  
Standard Symbols

7.6 Groove Weld Contour and Finish  
 8.6 Fillet Weld Contour and Finish  
 6.13 Contour Symbols

Grind flush (only if G is present)

flat G

convex

concave

68



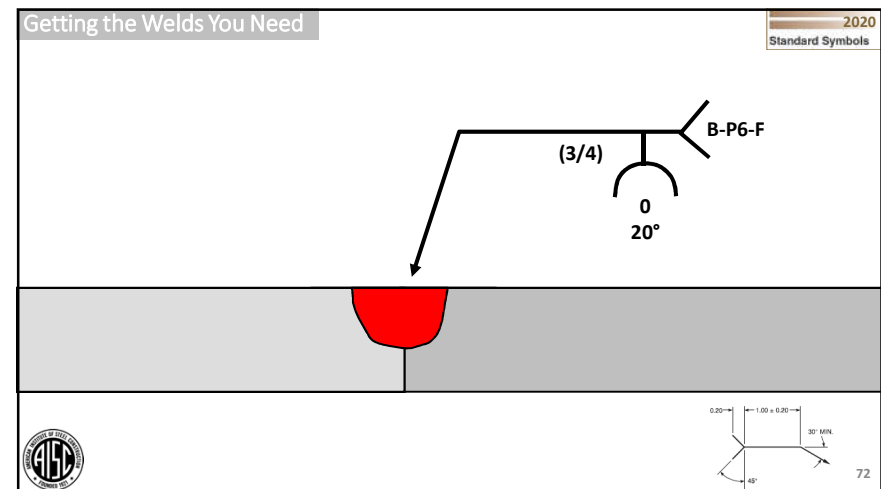
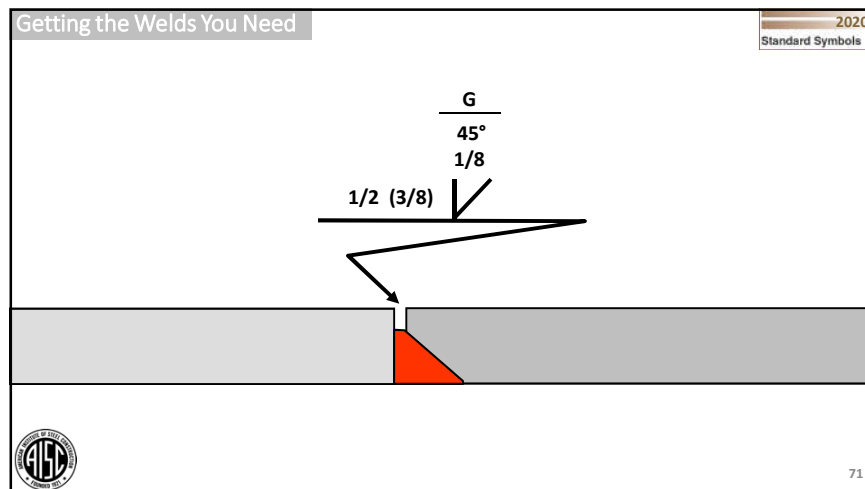
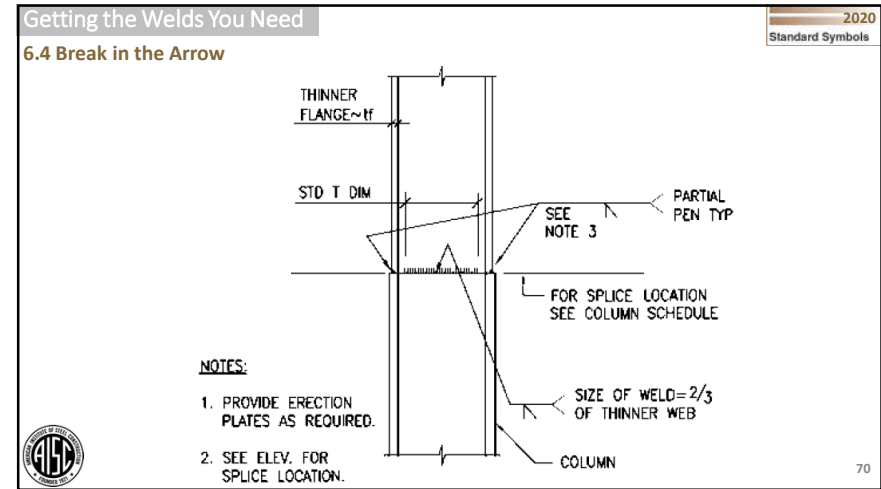
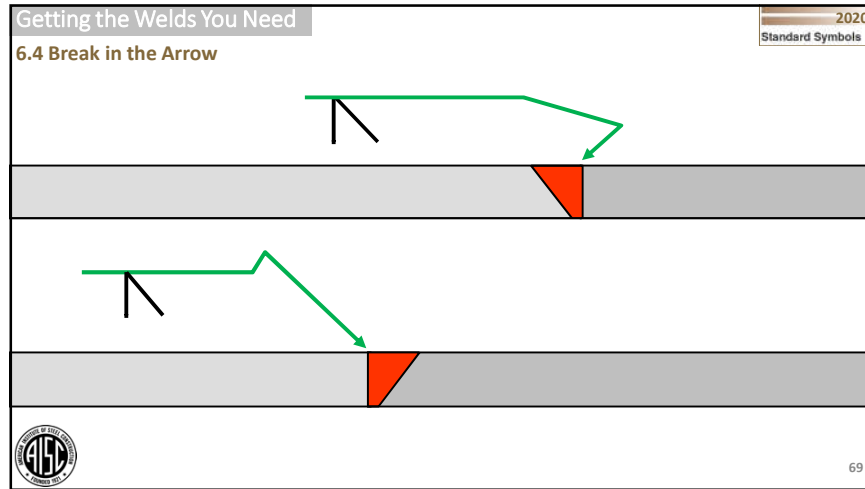



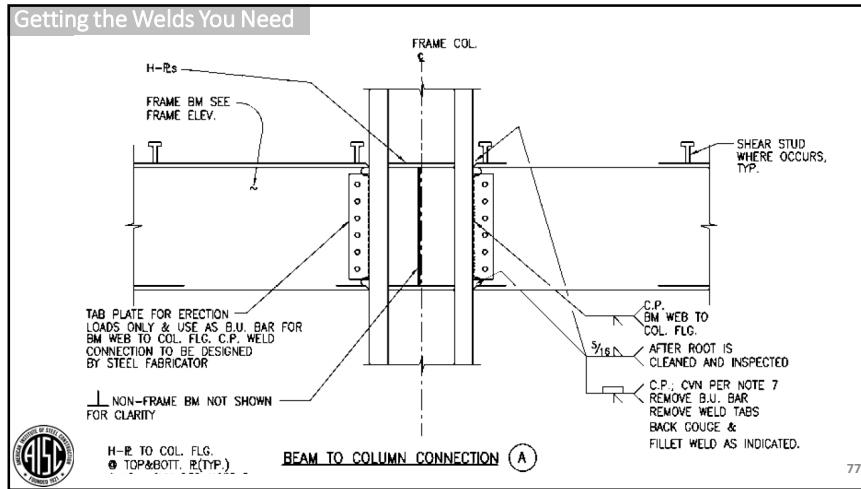

- Getting the Welds You Need
- welding symbols
  - joint details
  - document submittals
  - welding procedure specification (WPS) review
  - inspection
  - nondestructive testing
- 78

Getting the Welds You Need

J2 WELDS

Specification for Structural Steel Buildings

All provisions of the Structural Welding Code—Steel (AWS D1.1/D1.1M), hereafter referred to as AWS D1.1/D1.1M, apply under this Specification, with the exception that the provisions of the listed Specification sections apply under this Specification in lieu of the cited AWS provisions as follows:

- Section J1.6 in lieu of AWS D1.1/D1.1M clause 5.16
- Section J2.2a in lieu of AWS D1.1/D1.1M clauses 2.4.2.10 and 2.4.4.4
- Table J2.2 in lieu of AWS D1.1/D1.1M Table 2.1
- Table J2.5 in lieu of AWS D1.1/D1.1M Table 2.3
- Appendix 3, Table A-3.1 in lieu of AWS D1.1/D1.1M Table 2.5
- Section B3.11 and Appendix 3 in lieu of AWS D1.1/D1.1M clause 2, Part C
- Section M2.2 in lieu of AWS D1.1/D1.1M clauses 5.14 and 5.15

Structural Welding Code—Steel 2015

79

Getting the Welds You Need

4 Design of Welded Connections

Part B Specific Requirements for Design of Nontubular Connections (Statically or Cyclically Loaded)

4.9 Joint Configuration and Details - Fillet Welded Joints

4.9.3 Fillet Weld Terminations

4.9.3.1 General

Fillet weld terminations may extend to the ends or sides of parts or may be stopped short or may have end returns except as limited by the following cases: ...

Structural Welding Code—Steel 2020

80



Getting the Welds You Need

4 Design of Welded Connections  
Part B Specific Requirements for Design of Nontubular Connections  
(Statically or Cyclically Loaded)  
4.9 Joint Configuration and Details - Fillet Welded Joints  
4.9.3 Fillet Weld Terminations

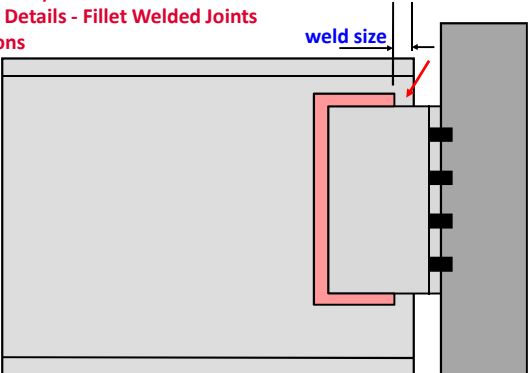

weld size





81

Structural Welding Code—Steel 2020

Detailed description: This diagram shows a vertical plate with a fillet weld along its edge. A red arrow points to the weld, and a blue dimension line indicates the weld size. The weld is shown terminating at the edge of the plate.

Getting the Welds You Need

4 Design of Welded Connections  
Part B Specific Requirements for Design of Nontubular Connections  
(Statically or Cyclically Loaded)  
4.9 Joint Configuration and Details - Fillet Welded Joints  
4.9.3 Fillet Weld Terminations

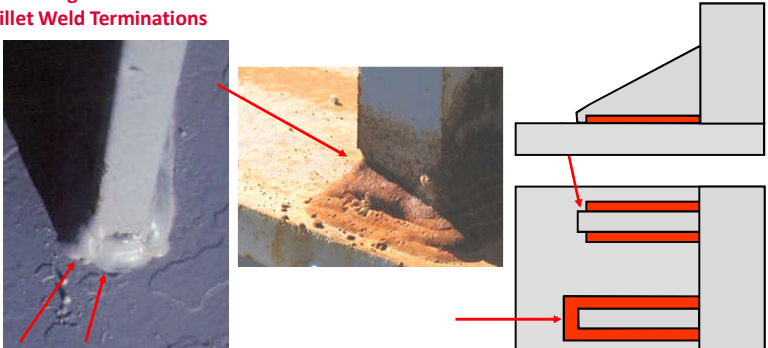

82

Structural Welding Code—Steel 2020

Detailed description: This slide contains three diagrams. On the left is a close-up photograph of a fillet weld termination on a vertical plate. In the middle is another close-up photograph of a fillet weld termination on a horizontal plate. On the right is a schematic diagram of a fillet weld termination on a vertical plate, with red arrows pointing to the weld and the termination point.

Getting the Welds You Need

4 Design of Welded Connections  
Part B Specific Requirements for Design of Nontubular Connections  
(Statically or Cyclically Loaded)  
4.9 Joint Configuration and Details - Fillet Welded Joints  
4.9.3 Fillet Weld Terminations

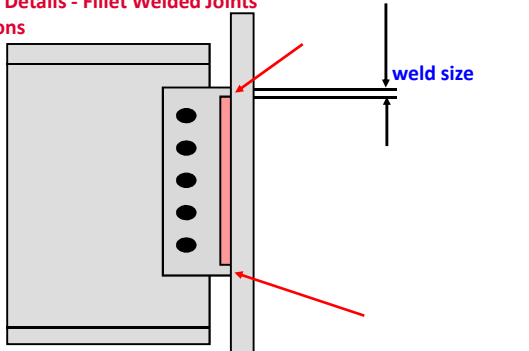

weld size



83

Structural Welding Code—Steel 2020

Detailed description: This diagram shows a vertical plate with a fillet weld along its edge. A red arrow points to the weld, and a blue dimension line indicates the weld size. The weld is shown terminating at the edge of the plate.

Getting the Welds You Need

4 Design of Welded Connections  
Part B Specific Requirements for Design of Nontubular Connections  
(Statically or Cyclically Loaded)  
4.9 Joint Configuration and Details - Fillet Welded Joints  
4.9.3 Fillet Weld Terminations

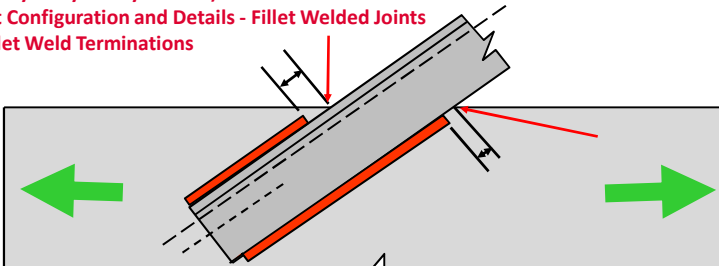

4.9.3.2 Lap Joints Subject to Tension

In lap joints in which one part extends beyond the edge or side of a part subject to calculated tensile stress, fillet welds **shall** terminate not less than the size of the weld from the start of the extension (see Figure 4.11).



84

Structural Welding Code—Steel 2020

Detailed description: This diagram shows a lap joint under tension. Two plates are overlapped, and a fillet weld is applied along the overlap. Green arrows indicate the direction of tensile force. A red arrow points to the weld, and a blue dimension line indicates the weld size. The weld is shown terminating at the edge of the plate.

Getting the Welds You Need

4 Design of Welded Connections  
Part B Specific Requirements for Design of Nontubular Connections  
(Statically or Cyclically Loaded)  
4.9 Joint Configuration and Details - Fillet Welded Joints  
4.9.3 Fillet Weld Terminations

**4.9.3.5 Opposite Sides of Common Plane**  
Fillet welds on the opposite sides of a common plane **shall** be interrupted at the corner common to both welds (see Figure 4.13).

85

Getting the Welds You Need

4 Design of Welded Connections  
Part B Specific Requirements for Design of Nontubular Connections  
(Statically or Cyclically Loaded)  
4.9 Joint Configuration and Details - Fillet Welded Joints  
4.9.3 Fillet Weld Terminations

**4.9.3.5 Opposite Sides of Common Plane**  
Fillet welds on the opposite sides of a common plane **shall be interrupted** at the corner common to both welds (see Figure 4.13), except as follows:  
**When joints are required to be sealed, or when a continuous weld is needed for other reasons, the contract documents shall specify where these welds are required to be continuous.**

86

Getting the Welds You Need

4 Design of Welded Connections  
Part B Specific Requirements for Design of Nontubular Connections  
(Statically or Cyclically Loaded)  
4.9 Joint Configuration and Details - Fillet Welded Joints  
4.9.3 Fillet Weld Terminations

**4.9.3.3 Maximum End Return Length**  
Welded joints shall be arranged to allow the flexibility assumed in the connection design. If the outstanding legs of connection base metal are attached with end returned welds, the length of the end return shall not exceed four times the nominal size of the weld (see Figure 4.12 for examples of flexible connections).

**Figure 4.12**

- Min 2 x weld size
- Max 4 x weld size

87

Getting the Welds You Need

4 Design of Welded Connections  
Part B Specific Requirements for Design of Nontubular Connections  
(Statically or Cyclically Loaded)  
4.8 Joint Configuration and Details—Groove Welds

**4.8.1 Transitions in Thicknesses and Widths**

For statically loaded structures, surface contouring fillet welds **need not be provided**.

**When surface contouring fillet welds are required by the Engineer, they shall be specified in the contract documents (...).**

88

Getting the Welds You Need

7 Fabrication  
7.9 Backing

7.9.1 Attachment of Steel Backing  
7.9.1.1 Fusion  
7.9.1.2 Full-Length Backing  
7.9.1.3 Backing Thickness  
7.9.1.4 Cyclically Loaded Nontubular Connections  
7.9.1.5 Statically Loaded Connections

7.9.2 Backing Welds  
7.9.3 Non-Steel Backing



Structural Welding Code—Steel 2020



89

Getting the Welds You Need

4 Design of Welded Connections  
Part C Specific Requirements for Design of Nontubular Connections  
(Cyclically Loaded)

4.17 Detailing, Fabrication, and Erection  
4.17.2 Backing  
4.17.2.1 Welds for Attaching Steel Backing

Requirements for welds for attaching steel backing and whether the backing shall be removed or left in place shall be determined as described in ..., and the stress range categories of Table 4.5.

The **Engineer** shall note the fatigue stress category on the **contract drawings**.



90

Getting the Welds You Need

7 Fabrication  
7.23 Weld Profiles  
7.23.4 Shelf Bars

Shelf bars shall conform to the requirements of 7.9.1.1 through 7.9.1.5.

Shelf bars may be left in place only for statically loaded members.

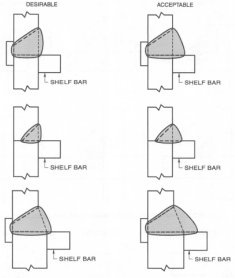

Structural Welding Code—Steel 2020



91

Getting the Welds You Need



7 Fabrication  
7.30 Weld Tabs (See 7.2.2)  
7.30.1 Use of Weld Tabs

Welds shall be terminated at the end of a joint in a manner that will ensure sound welds.

Whenever necessary, this shall be done by use of weld tabs aligned in such a manner to provide an extension of the joint preparation.

7.30.2 Removal of Weld Tabs for Statically Loaded Nontubular Structures

For statically loaded nontubular structures, weld tabs need not be removed unless required by the Engineer.

92

Getting the Welds You Need

7 Fabrication  
7.30 Weld Tabs (See 7.2.2)

7.30.2 Removal of Weld Tabs for Statically Loaded Nontubular Structures

For statically loaded nontubular structures, weld tabs need not be removed unless required by the *Engineer*.

7.30.3 Removal of Weld Tabs for **Cyclically** Loaded Nontubular Structures

For **cyclically** loaded nontubular structures, weld tabs shall be removed upon completion and cooling of the weld, and the ends of the weld shall be made smooth and flush with the edges of abutting parts.



93

Structural Welding Code—Steel 2020

Getting the Welds You Need

7 Fabrication  
7.17 Tack Welds and Construction Aid Welds

7.17.2 Exclusions

Tack welds and construction aid welds are permitted except that:  
...  
(2) On members made of quenched and tempered steel with specified yield strength greater than 70 ksi [485 MPa], tack welds outside the final weld and construction aid welds shall require the approval of the *Engineer*.

7.17.3 Removal

At locations other than 7.17.2, tack welds and construction aid welds, not incorporated into final welds, shall be removed when required by the *Engineer*.



94

Structural Welding Code—Steel 2020

Getting the Welds You Need

7 Fabrication  
7.12 Conformance with Design

The sizes and lengths of welds shall be no less than those specified by design requirements and detail drawings, except as allowed in Table 8.1 or Table 10.15.

The location of welds shall not be changed without approval of the *Engineer*.



95

Structural Welding Code—Steel 2020

Getting the Welds You Need

7 Fabrication  
7.25 Repairs  
7.25.3 Engineer's Approval

Prior approval of the *Engineer* shall be obtained for

- repairs to base metal (other than those required by 7.14),
- repair of major or delayed cracks,
- repairs to ESW and EGW with internal defects, or
- for a revised design to compensate for deficiencies.

The *Engineer* shall be notified before welded members are cut apart.



96

Structural Welding Code—Steel 2020



Getting the Welds You Need

- welding symbols
- joint details
- **document submittals**
- welding procedure specification (WPS) review
- inspection
- nondestructive testing



97

Getting the Welds You Need

Structural  
Welding Code—  
Steel 2020

**7 Fabrication**  
**7.3 Welding Consumables and Electrode Requirements**  
**7.3.1 General**

**7.3.1.1 Certification for Electrodes or Electrode-Flux Combinations**

**When requested by the Engineer**, the Contractor or fabricator shall furnish certification that the electrode or electrode-flux combination conforms to the requirements of the classification.

**7.3.1.3 Shielding Gas**

... **When requested by the Engineer**, the Contractor or fabricator shall furnish the gas manufacturer's certification that the gas or gas mixture conforms to the dew point requirements of AWS A5.32. ...



98

Getting the Welds You Need

Structural  
Welding Code—  
Steel 2020

**7 Fabrication**  
**7.20 Control of Distortion and Shrinkage**  
**7.20.3 Contractor Responsibility**

On members or structures where excessive shrinkage or distortion could be expected, the **Contractor shall** prepare a written welding sequence for that member or structure which meets the quality requirements specified.

The welding sequence and distortion control program shall be submitted to the Engineer, for information and comment, before the start of welding on the member or structure in which shrinkage or distortion is likely to affect the adequacy of the member or structure.



99

Getting the Welds You Need

**CHAPTER N**  
**QUALITY CONTROL AND QUALITY ASSURANCE**

- N1. General Provisions
- N2. Fabricator and Erector Quality Control Program
- N3. Fabricator and Erector Documents**
- N4. Inspection and Nondestructive Testing Personnel
- N5. Minimum Requirements for Inspection of Structural Steel Buildings
- N6. Approved Fabricators and Erectors
- N7. Nonconforming Material and Workmanship



100



Getting the Welds You Need

Specification for Structural Steel Buildings

**N3 FABRICATOR AND ERECTOR DOCUMENTS**  
**N3.2 Available Documents for Steel Construction**

The following documents **shall be available** in electronic or printed form for review by the **FOR** or the **FOR's designee** prior to fabrication or erection, as applicable, unless otherwise required in the contract documents to be submitted:

- (a) For main structural steel elements, copies of material test reports in accordance with Section A3.1.
- (b) For steel castings and forgings, copies of material test reports in accordance with Section A3.2.
- (c) For fasteners, copies of manufacturer's certifications in accordance with Section A3.3.
- (d) For anchor rods and threaded rods, copies of material test reports in accordance with Section A3.4.

...



101

Getting the Welds You Need

Specification for Structural Steel Buildings

**N3 FABRICATOR AND ERECTOR DOCUMENTS**  
**N3.2 Available Documents for Steel Construction**

...

- (e) For welding consumables, copies of manufacturer's certifications in accordance with Section A3.5
- (f) For headed stud anchors, copies of manufacturer's certifications in accordance with Section A3.6
- (g) Manufacturer's product data sheets or catalog data for welding filler metals and fluxes to be used. The data sheets shall describe the product, limitations of use, recommended or typical welding parameters, and storage and exposure requirements, including baking, if applicable.

...



102

Getting the Welds You Need

Specification for Structural Steel Buildings

**N3 FABRICATOR AND ERECTOR DOCUMENTS**  
**N3.2 Available Documents for Steel Construction**

...

- (h) Welding procedure specifications (WPS)
- (i) Procedure qualification records (PQR) for WPS that are not prequalified in accordance with *Structural Welding Code—Steel* (AWS D1.1/D1.1M), hereafter referred to as AWS D1.1/D1.1M, or *Structural Welding Code—Sheet Steel* (AWS D1.3/D1.3M), as applicable.
- (j) Welding personnel performance qualification records (WPQR) and continuity records

...



103

Getting the Welds You Need

Specification for Structural Steel Buildings

**N3 FABRICATOR AND ERECTOR DOCUMENTS**  
**N3.2 Available Documents for Steel Construction**

...

- (k) Fabricator's or erector's, as applicable, written QC manual, that shall include, as a minimum:
  - (1) Material control procedures
  - (2) Inspection procedures
  - (3) Nonconformance procedures
- (l) Fabricator's or erector's, as applicable, QCI qualifications.
- (m) Fabricator NDT personnel qualifications, if NDT is performed by the fabricator



104



Getting the Welds You Need

AISC 341-16  
J QUALITY CONTROL AND QUALITY ASSURANCE

- J1 Scope
- J2 Fabricator and Erector Documents
- J3 Quality Assurance Agency Documents
- J4 Inspection and Nondestructive Testing Personnel
- J5 Inspection Tasks
- J6 Welding Inspection and Nondestructive Testing
- J7 Inspection of High-Strength Bolting
- J8 Other Steel Structure Inspections
- J9 Inspection of Composite Structures
- J10 Inspection of Piling



105

Getting the Welds You Need

Seismic Provisions for Structural Steel Buildings

J2 Fabricator and Erector Documents  
J2.1 Documents to be Submitted for Steel Construction

In addition to the requirements of *Specification* Section N3.1, the following documents shall be **submitted for review by the engineer of record (EOR) or the EOR's designee**, prior to fabrication or erection of the affected work, as applicable:

- (a) Welding Procedure Specifications (WPS)
- (b) Copies of the manufacturer's typical certificate of conformance for all electrodes, fluxes and shielding gasses to be used



106

Getting the Welds You Need

Seismic Provisions for Structural Steel Buildings

J2 Fabricator and Erector Documents  
J2.1 Documents to be Submitted for Steel Construction

- (c) For demand critical welds, applicable manufacturer's certifications that the filler metal meets the supplemental notch toughness requirements, as applicable. When the filler metal manufacturer does not supply such supplemental certifications, the fabricator or erector, as applicable, shall have the necessary testing performed and provide the applicable test reports.
- (d) Manufacturer's product data sheets or catalog data for SMAW, FCAW and GMAW composite (cored) filler metals to be used
- (f) Specific assembly order, welding sequence, welding technique, or other special precautions for joints or groups of joints where such items are designated to be submitted to the engineer of record



107

Getting the Welds You Need

Seismic Provisions for Structural Steel Buildings

J2 Fabricator and Erector Documents  
J2.2 Documents to be Available for Review for Steel Construction

Additional documents **as required by the EOR** in the contract documents shall be **available** by the fabricator and erector **for review by the EOR or the EOR's designee** prior to fabrication or erection, as applicable.

The fabricator and erector shall retain their document(s) for at least one year after substantial completion of construction.



108

Getting the Welds You Need

Seismic Provisions  
for Structural  
Steel Buildings

### J3 Quality Assurance Agency Documents

The **agency responsible for quality assurance** shall submit the following documents to the *authority having jurisdiction*, the **EOR**, and the owner or owner's designee:

- QA agency's written practices for the monitoring and control of the agency's operations. The written practice shall include:
  - the agency's procedures for the selection and administration of inspection personnel, describing the training, experience and examination requirements for qualification and certification of inspection personnel; and
  - the agency's inspection procedures, including general inspection, material controls, and visual welding inspection.



109

Getting the Welds You Need

Seismic Provisions  
for Structural  
Steel Buildings

### J3 Quality Assurance Agency Documents

The agency responsible for *quality assurance* shall submit the following documents to the *authority having jurisdiction*, the engineer of record, and the owner or owner's designee:

- Qualifications of management and QA personnel designated for the project.
- Qualification records for Inspectors and NDT technicians designated for the project.
- NDT procedures and equipment calibration records for NDT to be performed and equipment to be used for the project.
- For composite construction, concrete testing procedures and equipment.



110

Getting the Welds You Need

- welding symbols
- joint details
- document submittals
- welding procedure specification (WPS) review
- inspection
- nondestructive testing



111

Getting the Welds You Need

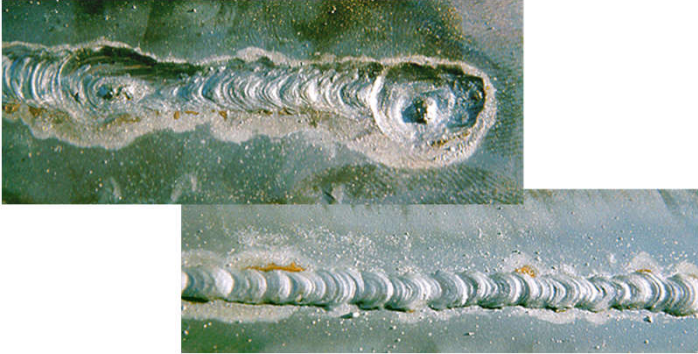

112



Getting the Welds You Need

NASCC: THE VIRTUAL STEEL CONFERENCE

**WPSs and WPS Qualification: Guidance for Engineers, Fabricators, and Erectors [O3]**

This session is for engineers who want to learn more about WPSs and WPS qualification as well as for fabricators and erectors who want to learn more about writing WPSs and conducting WPS qualification testing. We'll look at governing standards such as AISC 360, AISC 341, AWS D1.1, and AWS D1.8 and discuss things like how to write and review a WPS and when to consider WPS qualification even if it isn't required. What are the responsibilities of engineers, fabricators, and erectors regarding WPSs and WPS qualification when qualification is required? What are the limits to prequalification in AWS D1.1 and AWS D1.8? When should--or can--requirements for WPS qualification be waived? We'll answer all of that and more.

<https://www.aisc.org/education/continuingeducation/education-archives/wps-and-wps-qualification-guidance-for-engineers-fabricators-and-erectors-o3/>

[https://cloud.aisc.org/nascc/2020/O3\\_NASCC2020.mp4](https://cloud.aisc.org/nascc/2020/O3_NASCC2020.mp4)

114

Getting the Welds You Need

**Welding Procedure Specification (WPS)**

A document providing the detailed methods and practices involved in the production of a weldment.

- base metal
- base metal thickness
- type of joint
- type of weld
- position
- size of weld
- electrode class
- electrode size
- flux / shielding gas
- preheat / interpass temperature
- voltage
- polarity
- amperage (wire feed speed)
- shielding gas flow rate
- travel speed
- heat input
- progression
- number & position of passes
- stickout

115

Getting the Welds You Need

**Sample WPS using SMAW**

Groove	B-U4a
Position	Horizontal
Thickness	3/4
Groove Angle	45°
Root Opening	1/4
Electrode	E7018
Polarity	DCEP

Pass	First	2 - 11
Electrode	3/16	3/16
Travel Speed	5.5 - 6.5	6.2 - 6.8
Amperage	240	240

116



Getting the Welds You Need

Structural Welding Code—Steel 2020

## 5 Prequalification of WPSs

### 5.1 Scope

- Prequalification of WPSs (Welding Procedure Specifications) shall be defined as exempt from the WPS qualification testing required in Clause 6.
- All prequalified WPSs shall be written.
- In order for a WPS to be prequalified, conformance with all of the applicable requirements of **Clause 5** shall be required.
- WPSs that do not conform to the requirements of **Clause 5** may be qualified by tests in conformance with **Clause 6**.
- For convenience, **Annex K** lists provisions to be included in a prequalified WPS, and which should be addressed in the fabricator's or Contractor's welding program.



117

Getting the Welds You Need

Structural Welding Code—Steel 2020

## 6 Qualification



### Part A General Requirements

### 6.2 General

#### 6.2.1 Welding Procedure Specification (WPS)

#### 6.2.1.2 WPS Qualification to Other Standards

The acceptability of qualification to other standards is the **Engineer's** responsibility, to be exercised based upon either the specific structure or service conditions, or both.

118

Getting the Welds You Need

Structural Welding Code—Steel 2020

## 6 Qualification

### Part A General Requirements

### 6.2 General

#### 6.2.1 Welding Procedure Specification (WPS)

#### 6.2.1.2 WPS Qualification to Other Standards

...

AWS B2.1-X-XXX Series on *Standard Welding Procedure Specifications* may, in this manner, be accepted for use in this code....



119

Getting the Welds You Need

Structural Welding Code—Steel 2020

## 6 Qualification

### Part B Welding Procedure Specification (WPS) Qualification

### 6.8 Essential Variables

#### 6.8.3 Base Metal Qualification

WPSs requiring qualification that use base metals listed in Table 5.3 shall qualify other base metal groups in conformance with Table 6.8. WPSs for base metals not listed in Table 5.3 or Table 6.9 shall be qualified in conformance with Clause 4.

The use of unlisted base metals shall be approved by the **Engineer**.

...



120

Getting the Welds You Need

**Modern Steel Construction**

ARCHIVES

<https://www.aisc.org/modernsteel/archives/>

A look at materials and products that are not included in the AISC Specification's list of approved materials.

In this second of three articles, we continue the discussion of evaluating unlisted materials based on a list of factors provided in the Commentary to Section A3 of the AISC Specification.

In this third and final article in our series, we continue the discussion about unlisted materials, this time focusing in on considerations beyond those listed in the Commentary to the AISC Specification.

**steelwise UNLISTED MATERIALS – PART 1**  
BY LARRY S. MUIR, PE, AND THOMAS J. SCHLAFLY

**steelwise UNLISTED MATERIALS – PART 2**  
BY LARRY S. MUIR, PE, AND THOMAS J. SCHLAFLY

**steelwise UNLISTED MATERIALS – PART 3**  
BY LARRY S. MUIR, PE, AND THOMAS J. SCHLAFLY



Getting the Welds You Need

**AWS D1.1:2010 Annex N** ANNEX N AWS D1.1/D1.1M:2010

Structural Welding Code—Steel **2010**

WELDING PROCEDURE SPECIFICATION (WPS) Yes   
PREQUALIFIED QUALIFIED BY TESTING  
or PROCEDURE QUALIFICATION RECORDS (PQR) Yes

Company Name \_\_\_\_\_ Identification # \_\_\_\_\_  
Revision \_\_\_\_\_ Date \_\_\_\_\_ By \_\_\_\_\_  
Authorized by \_\_\_\_\_ Date \_\_\_\_\_  
Type—Manual  Semiautomatic   
Supporting PQR No.(s) \_\_\_\_\_ Mechanized  Automatic

JOINT DESIGN USED POSITION  
Type: Single  No  Double Weld  Position of Groove: \_\_\_\_\_ Fillet: \_\_\_\_\_  
Backing: Yes  No  Vertical Progression: Up  Down

Root Opening \_\_\_\_\_ Root Face Dimension \_\_\_\_\_  
Groove Angle \_\_\_\_\_ Radius (J-U) \_\_\_\_\_  
Back Gouging: Yes  No  Method \_\_\_\_\_

BASE METALS ELECTRICAL CHARACTERISTICS  
Material Spec. \_\_\_\_\_ Transfer Mode (GMAW) Short-Circuiting   
Type or Grade \_\_\_\_\_ Globular  Spray   
Thickness— Groove \_\_\_\_\_ Fillet \_\_\_\_\_  
Diameter (Pipe) \_\_\_\_\_ Power Source: CC  CV  Pulsed

Other \_\_\_\_\_  
Tungsten Electrode (GTAW) \_\_\_\_\_  
Size: \_\_\_\_\_  
Type: \_\_\_\_\_

FILLER METALS TECHNIQUE  
AWS Specification \_\_\_\_\_ Stringer or Weave Bead: \_\_\_\_\_  
AWS Classification \_\_\_\_\_ Multi-pass or Single Pass (per side) \_\_\_\_\_  
Number of Electrodes \_\_\_\_\_  
Electrode Spacing \_\_\_\_\_ Longitudinal \_\_\_\_\_  
Lateral \_\_\_\_\_  
Angle \_\_\_\_\_  
Contact Tube to Work Distance \_\_\_\_\_  
Peening \_\_\_\_\_  
Interpass Cleaning: \_\_\_\_\_

SHIELDING Flux \_\_\_\_\_ Gas \_\_\_\_\_ Composition \_\_\_\_\_  
Electrode-Flux (Class) \_\_\_\_\_ Flow Rate \_\_\_\_\_  
Gas Cup Size \_\_\_\_\_



Getting the Welds You Need

**AWS D1.1:2010 Annex N**

WELDING PROCEDURE SPECIFICATION (WPS) Yes   
PREQUALIFIED X QUALIFIED BY TESTING  
or PROCEDURE QUALIFICATION RECORDS (PQR) Yes

Structural Welding Code—Steel **2010**

WELDING PROCEDURE

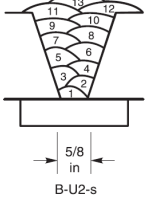
Pass or Weld Layer(s)	Process	Filler Metals		Current		Volts	Travel Speed	Joint Details
		Class	Diam.	Type & Polarity	Amps or Wire Feed Speed			
1-n	SAW	EM12K	5/32"	DC+	45 ipm 550 Amps ±10%	28 V ±7%	16 ipm ±15%	



Getting the Welds You Need

**AWS D1.1:2020 Annex J**

Structural Welding Code—Steel **2020**

Example WPS (Single-Process)  
WELDING PROCEDURE SPECIFICATION (WPS)

RED Inc. \_\_\_\_\_ 2010 \_\_\_\_\_ 0 \_\_\_\_\_ 12/01/2020  
Company Name \_\_\_\_\_ WPS No. \_\_\_\_\_ Rev. No. \_\_\_\_\_ Date \_\_\_\_\_  
J. Jones \_\_\_\_\_ 12/01/2015 \_\_\_\_\_ 231 \_\_\_\_\_ No \_\_\_\_\_  
Authorized by \_\_\_\_\_ Date \_\_\_\_\_ Supporting PQR(s) \_\_\_\_\_ CVN Report \_\_\_\_\_

BASE METALS	Specification	Type or Grade	AWS Group No.	BASE METAL THICKNESS	As-Welded	With PWHT
Base Material	ASTM A131	A	I	CJP Groove Welds	3/4–1-1/2 in	—
Welded To	ASTM A131	A	I	CJP Groove w/CVN	—	—
Backing Material	ASTM A131	A	I	PJP Groove Welds	—	—
Other				Filler Welds	—	—
				DIAMETER	—	—

JOINT DETAILS  
Groove Type: Single V Groove Butt Joint  
Groove Angle: 35° Included  
Root Opening: 1/4 in  
Root Face: —  
Backgouging: None  
Method: —

POSTWELD HEAT TREATMENT  
Temperature: None  
Time at Temperature: —  
Other: —

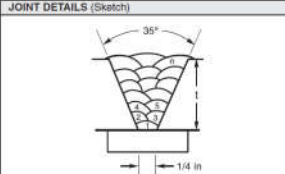
JOINT DETAILS (Sketch)  





Getting the Welds You Need

**AWS D1.1:2020 Annex J**

Structural Welding Code—Steel 2020

PROCEDURE		PROCEDURE	
Weld Layer(s)	All	Weld Layer(s)	All
Weld Pass(es)	All	Weld Pass(es)	All
Process	FCAW	Process	FCAW
Type (Semi-automatic, Mechanized, etc.)	Semiauto	Type (Semi-automatic, Mechanized, etc.)	Semiauto
Position	OH	Position	OH
Vertical Progression	—	Vertical Progression	—
Filler Metal (AWS Spec.)	A5.20	Filler Metal (AWS Spec.)	A5.20
AWS Classification	E71T-1C	AWS Classification	E71T-1C
Diameter	0.045 in	Diameter	0.045 in
Manufacturer/trade Name	—	Manufacturer/trade Name	—
Shielding Gas (Composition)	100% CO <sub>2</sub>	Shielding Gas (Composition)	100% CO <sub>2</sub>
Flow Rate	45–55 cfm	Flow Rate	45–55 cfm
Nozzle Size	#4	Nozzle Size	#4
Preheat Temperature	60° min.	Preheat Temperature	60° min.
Interpass Temperature	60°–350°	Interpass Temperature	60°–350°
Electrical Characteristics	—	Electrical Characteristics	—
Current Type & Polarity	DCEP	Current Type & Polarity	DCEP
Transfer Mode	—	Transfer Mode	—
Power Source Type (cc, cv, etc.)	CV	Power Source Type (cc, cv, etc.)	CV
Amps	180–220	Amps	180–220
Volts	25–26	Volts	25–26
Wire Feed Speed	—	Wire Feed Speed	—
Travel Speed	8–12 ipm	Travel Speed	8–12 ipm
Maximum Heat Input	—	Maximum Heat Input	—
Technique	—	Technique	—
Stringer or Weave	Stringer	Stringer or Weave	Stringer
Multi or Single Pass (per side)	Multipass	Multi or Single Pass (per side)	Multipass
Oscillation (Mechanized, Automatic)	—	Oscillation (Mechanized, Automatic)	—
Number of Electrodes	1	Number of Electrodes	1
Contact Tube to Work Dist.	1/2–1 in	Contact Tube to Work Dist.	1/2–1 in
Peening	None	Peening	None
Interpass Cleaning	Wire Brush	Interpass Cleaning	Wire Brush
Other	—	Other	—

Form J-2

125

Getting the Welds You Need

**Table 5.8 Prequalified Minimum Preheat and Interpass Temperature (see 5.7) Category B**

Structural Welding Code—Steel 2020

**Table 5.8 Prequalified Minimum Preheat and Interpass Temperature (see 5.7)**

C A T E G O R Y	Steel Specification	Welding Process	Thickness of Thickest Part at Point of Welding		Minimum Preheat and Interpass Temperature	
			in	mm	°F	°C
B	ASTM A139 Grade B	SMAW with low-hydrogen electrodes, SAW, GMAW, FCAW	1/8 to 3/4 incl.	3 to 20 incl.	32*	0*
	ASTM A381 Grade Y35					
	ASTM A500 Grades A, B, C					
	ASTM A501 Grades A, B		Over 3/4 thru 1-1/2 incl.	Over 20 thru 38 incl.	50	10
	ASTM A516 Grades 55, 60, 65, 70					
	ASTM A524 Grades I, II		Over 1-1/2 thru 2-1/2 incl.	Over 38 thru 65 incl.	150	65
	ASTM A529 Grades 50, 55					
	ASTM A537 Classes 1, 2					
ASTM A572 Grades 42, 50, 55						
ASTM A573 Grades 58, 65						
ASTM A588						
			Over 2-1/2	Over 65	225	110

126

Getting the Welds You Need

**Table 5.8 Prequalified Minimum Preheat and Interpass Temperature (see 5.7) Category C**

Structural Welding Code—Steel 2020

**Table 5.8 Prequalified Minimum Preheat and Interpass Temperature (see 5.7)**

C A T E G O R Y	Steel Specification	Welding Process	Thickness of Thickest Part at Point of Welding		Minimum Preheat and Interpass Temperature	
			in	mm	°F	°C
C	ASTM A709 <sup>b</sup> Grade HPS70W	SMAW with low-hydrogen electrodes, SAW, GMAW, FCAW	1/8 to 3/4 incl.	3 to 20 incl.	50	10
	ASTM A710 Grade A, Class 2 ≤ 2 in [50 mm]					
	ASTM A710 Grade A, Class 3 > 2 in [50 mm]		Over 3/4 thru 1-1/2 incl.	Over 20 thru 38 incl.	150	65
	ASTM A913 Grades 60, 65, 70					
	ASTM A1018 HSLAS Grade 60 Class 2		Over 1-1/2 thru 2-1/2 incl.	Over 38 thru 65 incl.	225	110
	ASTM A1018 HSLAS-F Grade 70 Class 2					
ASTM A1066 Grades 60, 65, 70	Over 2-1/2	Over 65	300	150		

127

Getting the Welds You Need

**Table 5.8 Prequalified Minimum Preheat and Interpass Temperature (see 5.7) Category D**

Structural Welding Code—Steel 2020

**Table 5.8 Prequalified Minimum Preheat and Interpass Temperature (see 5.7)**

C A T E G O R Y	Steel Specification	Welding Process	Thickness of Thickest Part at Point of Welding		Minimum Preheat and Interpass Temperature	
			in	mm	°F	°C
D	ASTM A710 Grade A (All classes)	SMAW, SAW, GMAW, and FCAW with electrodes or electrode-flux combinations capable of depositing weld metal with a maximum diffusible hydrogen content of 8 ml/100 g (H <sub>8</sub> ) when tested according to AWS A4.3.	All thicknesses Over 1/8 in	All thicknesses Over [3 mm]	32*	0*
	ASTM A913 Grades 50, 60, 65					

128



Getting the Welds You Need

**Table 5.8 Prequalified Minimum Preheat and Interpass Temperature (see 5.7)**  
**Category E**

Structural Welding Code—Steel 2020

**Table 5.8**  
**Prequalified Minimum Preheat and Interpass Temperature (see 5.7)**

C A T E G O R Y	Steel Specification	Welding Process	Thickness of Thickest Part at Point of Welding		Minimum Preheat and Interpass Temperature	
			in	mm	°F	°C
E	ASTM A1066 Grades 50, 60, 65  ASTM A1066 / A1066M – High-Strength Low-Alloy Structural Steel Plate Produced by Thermo-Mechanical Controlled Process (TMCP)	SMAW, SAW, GMAW, and FCAW with electrodes or electrode-flux combinations capable of depositing weld metal with a maximum diffusible hydrogen content of 8 ml/100 g (H <sub>8</sub> ), when tested according to AWS A4.3.	1/8 to 1 incl.	3 to 25 incl.	50	10
			Over 1	Over 25	120	50

129

Getting the Welds You Need

**Preheat**

AWS D14.8M:2009  
(ISO/TR 17844:2004 IDT)  
An American National Standard

**3 CET-method**

- 3.1 Cracking test method
- 3.2 Parent metal composition range
- 3.3 Plate thickness
- 3.4 Hydrogen level and welding process
- 3.5 Heat input
- 3.6 Influence of residual stress
- 3.7 Determination of preheat
- 3.8 Special considerations

**Standard Methods for the Avoidance of Cold Cracks**

$$T_p = T_{pCET} + T_{pd} + T_{pHD} + T_{pQ}$$

130

Getting the Welds You Need

**INNERSHIELD® WIRES PRODUCT CATALOG**

**OUTERSHIELD® WIRES**



Gas-Shielded, Flux-Cored Wires



Gas-Shielded Flux-Cored & Metal-Cored Wires

131

Getting the Welds You Need

**INNERSHIELD NR-232** AWS A5.20-95: E71T-8

**TYPICAL OPERATING PROCEDURES**

Wire, Polarity Electrical Stickout Wire Weight	Wire Feed Speed in/min (m/min)	Arc Voltage (volts)	Approx. Current (amps)	Melt-Off Rate lbs/hr (kg/hr)	Deposition Rate lbs/hr (kg/hr)	Efficiency (%)	
.068" DC- 1/2-1" (12-25mm) .755 lbs/1000'	110 (2.7)	19	195	5.0 (2.3)	3.9 (1.8)	78	
	130 (3.3)	20	225	6.2 (2.8)	4.6 (2.0)	74	
	150 (3.8)	20	250	7.1 (3.2)	5.3 (2.4)	75	
	170 (4.3)	21	270	7.8 (3.5)	6.1 (2.8)	78	
	195 (5.0)	23.5	300	9.4 (4.3)	7.0 (3.2)	74	
.072" DC- 1/2-1" (12-25mm) .778 lbs/1000'	250 (6.4)	23	315	11.7 (5.3)	9.6 (4.3)	82	
	320 (7.4)	26	400	15.2 (6.9)	11.4 (5.2)	75	
	80 (2.0)	17	130	4.0 (1.8)	3.3 (1.5)	83	
	140 (3.6)	19.5	225	6.8 (3.1)	5.5 (2.5)	81	
	155 (3.9)	20.5	240	7.2 (3.3)	6.0 (2.7)	83	
1/2-1" (12-25mm) .778 lbs/1000'	170 (4.3)	21.5	255	8.0 (3.6)	6.5 (2.9)	81	
	250 (6.4)	23	315	11.7 (5.3)	9.6 (4.3)	82	
	290 (7.4)	24	350	13.6 (6.2)	11.0 (5.0)	81	
	5/64"	60 (1.5)	16.5	145	3.7 (1.7)	2.7 (1.2)	73
	115 (2.9)	19.5	260	7.0 (3.2)	5.5 (2.5)	78	
DC- 1/2-1" (12-25mm) 1.000 lbs/1000'	120 (3.0)	19.5	270	7.3 (3.3)	5.7 (2.6)	78	
	130 (3.3)	20.5	285	7.8 (3.5)	6.2 (2.8)	79	
	180 (4.6)	22.5	365	10.9 (5.0)	8.7 (3.9)	80	

NOTE: Above typical operating procedures are starting points and may be adjusted as required.

132





Getting the Welds You Need

**CHAPTER 8**  
**WELDING PROCEDURE SPECIFICATIONS**

- 8.1 INTRODUCTION
- 8.2 WRITING WELDING PROCEDURE SPECIFICATIONS
- 8.3 USING WELDING PROCEDURE SPECIFICATIONS
- 8.4 PREQUALIFIED WELDING PROCEDURE SPECIFICATIONS
- 8.5 QUALIFIED WELDING PROCEDURE SPECIFICATIONS
- 8.6 WPS AND AWS D1.5
- 8.7 WPS AND AWS D1.8
- 8.8 EFFECTS OF WPS VARIABLES
- 8.9 SAMPLE FORMS
- 8.10 CODE-COMPLIANT VERSUS USEFUL WPS

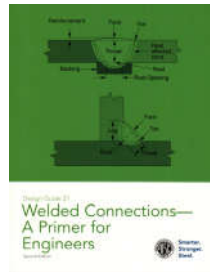

137

Getting the Welds You Need

- welding symbols
- joint details
- document submittals
- welding procedure specification (WPS) review
- **inspection**
- nondestructive testing



138

Getting the Welds You Need



139

Getting the Welds You Need

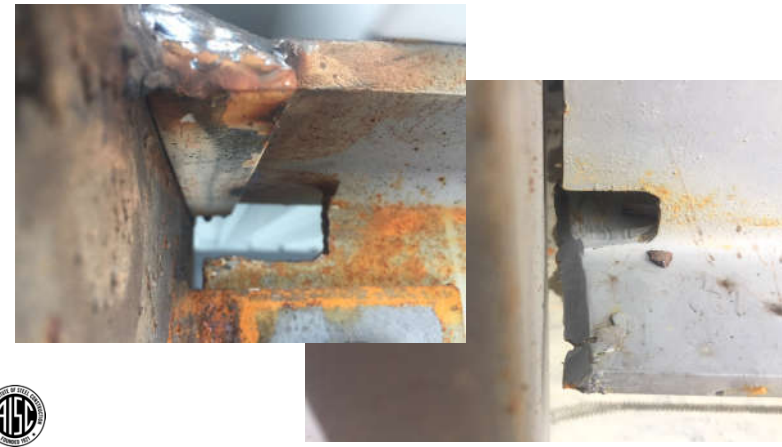

140



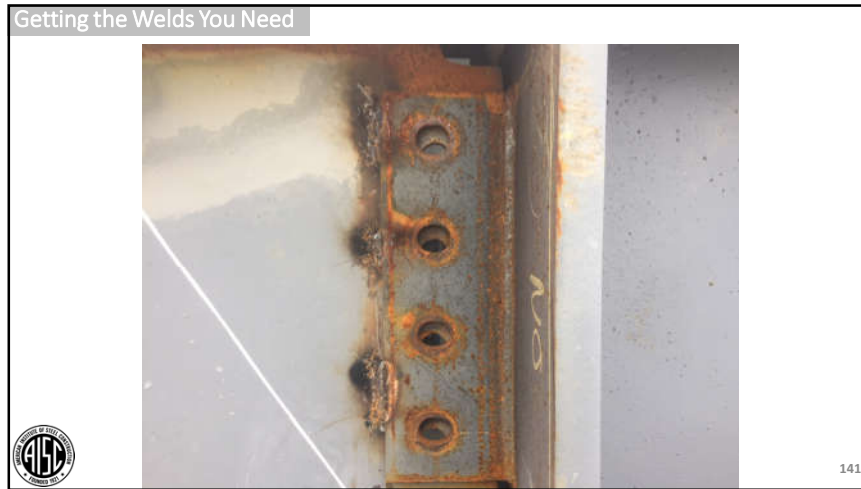

Getting the Welds You Need International Building Code

**17 Special Inspections and Tests**  
**1705.2 Steel construction**  
**1705.2.1 Structural steel**

*Special inspections* and nondestructive testing of *structural steel elements* in buildings, structures and portions thereof shall be in accordance with the quality assurance inspection requirements of **AISC 360**.

2015

2010

Chapter N

2018

2017

142

Getting the Welds You Need Specification for Structural Steel Buildings

**N5 MINIMUM REQUIREMENTS FOR INSPECTION OF STRUCTURAL STEEL BUILDINGS**  
**N5.4 Inspection of Welding**

Observation of welding operations and visual inspection of in-process and completed welds shall be the primary method to confirm that the materials, procedures and workmanship are in conformance with the construction documents.

143

Getting the Welds You Need Specification for Structural Steel Buildings

**N5 MINIMUM REQUIREMENTS FOR INSPECTION OF STRUCTURAL STEEL BUILDINGS**  
**N5.4 Inspection of Welding**

As a minimum, welding inspection tasks shall be in accordance with Tables N5.4-1, N5.4-2 and N5.4-3. In these tables, the inspection tasks are as follows:

- (a) **Observe (O):** The inspector shall observe these items on a random basis. Operations need not be delayed pending these inspections.
- (b) **Perform (P):** These tasks shall be performed for each welded joint or member.

144



Getting the Welds You Need		Specification for Structural Steel Buildings	
<b>N5 MINIMUM REQUIREMENTS FOR INSPECTION OF STRUCTURAL STEEL BUILDINGS</b>			
<b>N5.4 Inspection of Welding – Table N5.4-1</b>			
<b>Inspection Tasks Prior to Welding</b>	<b>QC</b>	<b>QA</b>	
Welder qualification records and continuity records	P	O	
WPS available	P	P	
Manufacturer certifications for welding consumables available	P	P	
Material identification (type/grade)	O	O	
Welder identification system <sup>[a]</sup>	O	O	
...			
Check welding equipment	O	-	
[a] The fabricator or erector, as applicable, shall maintain a system by which a welder who has welded a joint or member can be identified. Stamps, if used, shall be the low-stress type			
		145	

Getting the Welds You Need		Specification for Structural Steel Buildings	
<b>N5 MINIMUM REQUIREMENTS FOR INSPECTION OF STRUCTURAL STEEL BUILDINGS</b>			
<b>N5.4 Inspection of Welding – Table N5.4-1</b>			
<b>Inspection Tasks Prior to Welding</b>	<b>QC</b>	<b>QA</b>	
<b>Fit-up of groove welds (including joint geometry)</b>			
<ul style="list-style-type: none"> <li>Joint preparations</li> <li>Dimensions (alignment, root opening, root face, bevel)</li> <li>Cleanliness (condition of steel surfaces)</li> <li>Tacking (tack weld quality and location)</li> <li>Backing type and fit (if applicable)</li> </ul>	O	O	
<b>Fit-up of CJP groove welds of HSS T-, Y- and K-joints without backing (including joint geometry)</b>			
<ul style="list-style-type: none"> <li>Joint preparations</li> <li>Dimensions (alignment, root opening, root face, bevel)</li> <li>Cleanliness (condition of steel surfaces)</li> <li>Tacking (tack weld quality and location)</li> </ul>	P	O	
		146	

Getting the Welds You Need		Specification for Structural Steel Buildings	
<b>N5 MINIMUM REQUIREMENTS FOR INSPECTION OF STRUCTURAL STEEL BUILDINGS</b>			
<b>N5.4 Inspection of Welding – Table N5.4-1</b>			
<b>Inspection Tasks Prior to Welding</b>	<b>QC</b>	<b>QA</b>	
Configuration and finish of access holes	O	O	
<b>Fit-up of fillet welds</b>			
<ul style="list-style-type: none"> <li>Dimensions (alignment, gaps at root)</li> <li>Cleanliness (condition of steel surfaces)</li> <li>Tacking (tack weld quality and location)</li> </ul>	O	O	
		147	

Getting the Welds You Need		Specification for Structural Steel Buildings	
<b>Commentary TABLE C-N5.4-1</b>			
<b>Reference to AWS D1.1/D1.1M 2015</b>			
<b>Clauses for Inspection Tasks Prior to Welding</b>			
<b>Inspection Tasks Prior to Welding</b>	<b>AWS D1.1/D1.1M References</b>		
Welder qualification records and continuity records	6.4 (welder qualification)		
WPS available	6.3		
Manufacturer certifications for welding consumables available	6.2		
Material identification (type/grade)	6.2		
Welder identification system	identification system not required by AWS D1.1/D1.1M		
Check welding equipment	6.2, 5.10		
		148	



Getting the Welds You Need		
Specification for Structural Steel Buildings		
N5 MINIMUM REQUIREMENTS FOR INSPECTION OF STRUCTURAL STEEL BUILDINGS		
N5.4 Inspection of Welding – Table N5.4-2		
Inspection Tasks During Welding	QC	QA
<b>Control and handling of welding consumables</b>		
<ul style="list-style-type: none"> <li>• Packaging</li> <li>• Exposure control</li> </ul>	O	O
<b>No welding over cracked tack welds</b>	O	O
<b>Environmental conditions</b>		
<ul style="list-style-type: none"> <li>• Wind speed within limits</li> <li>• Precipitation and temperature</li> </ul>	O	O
...		
<b>Placement and installation of steel headed stud anchors</b>	P	P
 <span style="float: right;">149</span>		

Getting the Welds You Need		
Specification for Structural Steel Buildings		
N5 MINIMUM REQUIREMENTS FOR INSPECTION OF STRUCTURAL STEEL BUILDINGS		
N5.4 Inspection of Welding – Table N5.4-2		
Inspection Tasks During Welding	QC	QA
<b>WPS followed</b>		
<ul style="list-style-type: none"> <li>• Settings on welding equipment</li> <li>• Travel speed</li> <li>• Selected welding materials</li> <li>• Shielding gas type/flow rate</li> <li>• Preheat applied</li> <li>• Interpass temperature maintained (min./max.)</li> <li>• Proper position (F, V, H, OH)</li> </ul>	O	O
<b>Welding techniques</b>		
<ul style="list-style-type: none"> <li>• Interpass and final cleaning</li> <li>• Each pass within profile limitations</li> <li>• Each pass meets quality requirements</li> </ul>	O	O
 <span style="float: right;">150</span>		

Getting the Welds You Need		
Specification for Structural Steel Buildings		
N5 MINIMUM REQUIREMENTS FOR INSPECTION OF STRUCTURAL STEEL BUILDINGS		
N5.4 Inspection of Welding – Table N5.4-3		
Inspection Tasks After Welding	QC	QA
<b>Welds cleaned</b>	O	O
<b>Size, length, and location of welds</b>	P	P
<b>Welds meet visual acceptance criteria</b>		
<ul style="list-style-type: none"> <li>• Crack prohibition</li> <li>• Weld/base-metal fusion</li> <li>• Crater cross-section</li> <li>• Weld profiles</li> <li>• Weld size</li> <li>• Undercut</li> <li>• Porosity</li> </ul>	P	P
<b>Arc strikes</b>	P	P
...		
 <span style="float: right;">151</span>		

Getting the Welds You Need		
Specification for Structural Steel Buildings		
N5 MINIMUM REQUIREMENTS FOR INSPECTION OF STRUCTURAL STEEL BUILDINGS		
N5.4 Inspection of Welding – Table N5.4-3		
Inspection Tasks After Welding	QC	QA
...		
<b>k-area</b> <sup>[a]</sup>	P	P
<b>Weld access holes in rolled heavy shapes and built-up heavy shapes</b> <sup>[b]</sup>	P	P
<b>Backing removed and weld tabs removed (if required)</b>	P	P
<b>Repair activities</b>	P	P
<b>Document acceptance or rejection of welded joint or member</b>	P	P
<b>No prohibited welds have been added without the approval of the EOR</b>	O	O
<p>[a] When welding of doubler plates, continuity plates, or stiffeners has been performed in the k-area, visually inspect the web k-area for cracks within 3 in. [75 mm] of the weld.</p> <p>[b] After rolled heavy shapes (see Section A3.1c) and built-up heavy shapes (see Section A3.1d) are welded, visually inspect the weld access hole for cracks.</p>		
 <span style="float: right;">152</span>		



Getting the Welds You Need

Structural Welding Code—Steel 2020

**8 Inspection**  
**Part A General Requirements**  
**8.1.2 Inspection and Contract Stipulations**

**8.1.2.1 Contractor's Inspection**

This type of inspection and test shall be performed as necessary

- prior to assembly,
- during assembly,
- during welding, and
- after welding

to ensure that materials and workmanship meet the requirements of the contract documents.

Fabrication/erection inspection and testing shall be the responsibilities of the **Contractor** unless otherwise provided in the contract documents.



153

Getting the Welds You Need

Structural Welding Code—Steel 2020

**8 Inspection**  
**Part A General Requirements**  
**8.1.2 Inspection and Contract Stipulations**

**8.1.2.2 Verification Inspection**

This type of inspection and testing shall be performed and their results reported to the Owner and Contractor in a timely manner to avoid delays in the work.

Verification inspection and testing are the **prerogatives of the Owner** who

- may perform this function or,
- when provided in the contract,
  - waive independent verification, or
  - stipulate that both inspection and verification shall be performed by the **Contractor**.



154

Getting the Welds You Need

Structural Welding Code—Steel 2020

**8 Inspection**  
**Part A General Requirements**  
**8.1.3 Definition of Inspection Categories**

**8.1.3.1 Contractor's Inspector**

This inspector is the duly designated person who **acts for, and in behalf of, the Contractor** on all inspection and quality matters within the scope of the contract documents.

**8.1.3.2 Verification Inspector**

This inspector is the duly designated person who **acts for, and in behalf of, the Owner or Engineer** on all inspection and quality matters within the scope of the contract documents.



155

Getting the Welds You Need

Structural Welding Code—Steel 2020

**1 General Requirements**  
**1.5 Responsibilities**  
**1.5.3 Inspector's Responsibilities**

**1.5.3.1 Contractor Inspection**

Contractor inspection shall be supplied by the **Contractor** and shall be performed as necessary to ensure that materials and workmanship meet the requirements of the contract documents.



156



Getting the Welds You Need

**1 General Requirements**  
**1.5 Responsibilities**  
**1.5.3 Inspector's Responsibilities**  
**1.5.3.2 Verification Inspection**

The **Engineer** shall determine if Verification Inspection shall be performed.

Responsibilities for Verification Inspection shall be established between the **Engineer** and the **Verification Inspector**.



Structural Welding Code—  
Steel 2020

157

Getting the Welds You Need

**8 Inspection**  
**Part A General Requirements**  
**8.2 Inspection of Materials and Equipment**

The **Contractor's Inspector** shall ensure that only materials and equipment conforming to the requirements of this code shall be used.



Structural Welding Code—  
Steel 2020

158

Getting the Welds You Need

**8 Inspection**  
**Part A General Requirements**  
**8.3 Inspection of WPSs**  
**8.3.1 Prequalified WPS**

The **Contractor's Inspector** shall ensure that all prequalified WPSs to be used for the work conform with the requirements Clause 5, 7, 10 (if tubular), and the contract documents.

**8.3.2 WPSs Qualified by Test**

The **Contractor's Inspector** shall ensure that all WPSs qualified by test conform with the requirements of Clauses 6, 7, 10 (if tubular), and contract documents.

**8.3.3 WPSs in Production**

The **Contractor's Inspector** shall ensure that all welding operations are performed in conformance with WPSs that meet the requirements of this code and the contract documents.



Structural Welding Code—  
Steel 2020

159

Getting the Welds You Need

**8 Inspection**  
**Part A General Requirements**  
**8.4 Inspection of Welder, Welding Operator, and Tack Welder Qualifications**  
**8.4.1 Determination of Qualification**

The Inspector shall allow welding to be performed only by welders, welding operators, and tack welders who are qualified in conformance with the requirements of Clause 6, or Clause 10 for tubulars,

or shall ensure that each welder, welding operator, or tack welder has previously demonstrated such qualification under other acceptable supervision and approved by the Engineer in conformance with 6.2.2.1.



Structural Welding Code—  
Steel 2020

160



Getting the Welds You Need

**8 Inspection**  
**Part A General Requirements**  
**8.5 Inspection of Work and Records**  
**8.5.1 Size, Length, and Location of Welds**

The Inspector shall ensure that the

- size,
- length, and
- location

of all welds conform to the requirements of this code and to the detail drawings and that no unspecified welds have been added without the approval of the **Engineer**.



161

Structural Welding Code—Steel 2020

Getting the Welds You Need

**8 Inspection**  
**Part A General Requirements**  
**8.5 Inspection of Work and Records**  
**8.5.2 Scope of Examinations**

The Inspector shall, at suitable intervals, observe

- joint preparation,
- assembly practice,
- the welding techniques, and
- performance of each welder, welding operator, and tack welder to ensure that the applicable requirements of this code are met.



162

Structural Welding Code—Steel 2020

Getting the Welds You Need

**8 Inspection**  
**Part A General Requirements**  
**8.5 Inspection of Work and Records**  
**8.5.3 Extent of Examination**

The Inspector shall examine the work to ensure that it meets the requirements of this code.

Other acceptance criteria, different from those described in the code, may be used when approved by the **Engineer**.

Size and contour of welds shall be measured with suitable gages.

Visual inspection for cracks in welds and base metal and other discontinuities should be aided by a strong light, magnifiers, or such other devices as may be found helpful.



163

Structural Welding Code—Steel 2020

Getting the Welds You Need

**8 Inspection**  
**Part A General Requirements**  
**8.5 Inspection of Work and Records**  
**8.5.4 Inspector Identification of Inspections Performed**

Inspectors shall identify with a distinguishing mark or other recording methods all parts or joints that they have inspected and accepted.

Any recording method which is mutually agreeable may be used.

Die stamping of cyclically loaded members without the approval of the **Engineer** shall be prohibited.



164

Structural Welding Code—Steel 2020



Getting the Welds You Need

**CHAPTER N**  
**QUALITY CONTROL AND QUALITY ASSURANCE**

- N1 General Provisions
- N2 Fabricator and Erector Quality Control Program
- N3 Fabricator and Erector Documents
- N4 Inspection and Nondestructive Testing Personnel**
- N5 Minimum Requirements for Inspection of Structural Steel Buildings
- N6 Approved Fabricators and Erectors
- N7 Nonconforming Material and Workmanship



165

Getting the Welds You Need

**8 Inspection**  
**Part A General Requirements**  
**8.1.4 Qualification of Inspection Personnel**

**8.1.4.1 Engineer's Responsibilities**

If the **Engineer** requires a specific basis of inspection personnel qualification other than those listed in 8.1.4.2, the basis shall be designated in the contract documents.

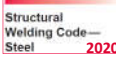

166

Getting the Welds You Need

**8 Inspection**  
**Part A General Requirements**  
**8.1.4 Qualification of Inspection Personnel**

**8.1.4.2 Basis for Qualification of Welding Inspectors**

Inspectors responsible for acceptance or rejection of material and workmanship on the basis of visual inspection shall be qualified.

The acceptable qualification basis shall be one of the following:

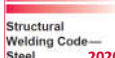



167

Getting the Welds You Need

**8 Inspection**  
**Part A General Requirements**  
**8.1.4 Qualification of Inspection Personnel**

**8.1.4.2 Basis for Qualification of Welding Inspectors**

(1) Current or previous certification as an AWS Certified Welding Inspector (CWI) or Senior Certified Welding Inspector (SCWI) in conformance with the requirements of AWS QC1, *Standard for AWS Certification of Welding Inspectors*, AWS QC1: 2016-AMD1



168



Getting the Welds You Need

**8 Inspection**  
**Part A General Requirements**  
**8.1.4 Qualification of Inspection Personnel**

**8.1.4.2 Basis for Qualification of Welding Inspectors**

(2) Current or previous certification as a Level 2 or Level 3 Welding Inspector in conformance with the requirements of Canadian Standards Association (CSA) Standard W178.2, *Certification of Welding Inspectors*,



169

Structural Welding Code—Steel 2020

Getting the Welds You Need

**8 Inspection**  
**Part A General Requirements**  
**8.1.4 Qualification of Inspection Personnel**

**8.1.4.2 Basis for Qualification of Welding Inspectors**

(3) Current or previous qualification as a Welding Inspector (WI) or Senior Welding Inspector (SWI) in conformance with the requirements of AWS B5.1, *Specification for the Qualification of Welding Inspectors*,

AWS B5.1:2013-AMD1  
An American National Standard



170

Structural Welding Code—Steel 2020

Getting the Welds You Need

**8 Inspection**  
**Part A General Requirements**  
**8.1.4 Qualification of Inspection Personnel**

**8.1.4.2 Basis for Qualification of Welding Inspectors**

(4) Current or previous qualification as an ASNT SNT-TC-1A-VT Level II in conformance with the requirements of ASNT Recommended Practice No. SNT-TC- 1A, *Personnel Qualification and Certification in Nondestructive Testing*, or ANSI/ASNT CP-189, *ASNT Standard for Qualification and Certification of Nondestructive Personnel*, or



171

Structural Welding Code—Steel 2020

Getting the Welds You Need

**8 Inspection**  
**Part A General Requirements**  
**8.1.4 Qualification of Inspection Personnel**

**8.1.4.2 Basis for Qualification of Welding Inspectors**

(5) An individual who, by training or experience, or both, in metals fabrication, inspection and testing, is competent to perform inspection of the work.

172

Structural Welding Code—Steel 2020



Getting the Welds You Need

8 Inspection  
Part A General Requirements  
8.1.4 Qualification of Inspection Personnel

8.1.4.3 Alternative Inspector Qualifications

The basis of alternative qualification for inspection personnel shall be specified in contract documents if different than the requirements in 8.1.4.2.

When requested by the **Engineer**, or an authorized representative of the owner, documentation of the specified alternative qualification of inspection personnel shall be submitted for verification and approval.



Structural Welding Code—Steel 2020

173

Getting the Welds You Need

8 Inspection  
Part A General Requirements  
8.1.4 Qualification of Inspection Personnel

8.1.4.5 Basis for Qualification of Assistant Inspectors

Assistant Inspectors shall be qualified to perform the specific functions to which they are assigned.

The acceptable qualification basis shall be one of the following:

- (1) Certified Associate Welding Inspector (CAWI) or higher (AWS QC1)
- (2) Level 1 Welding Inspector or higher (CSA W178.2)
- (3) Associate Welding Inspector (AWI) or higher (AWS B5.1)
- (4) VT Level 1 (ASNT SNT-TC-1A, ANSI/ASNT CP-189)
- (5) An individual who is qualified by training and experience to perform the specific functions they are assigned.



Structural Welding Code—Steel 2020

174

Getting the Welds You Need

8 Inspection  
Part A General Requirements  
8.1.4 Qualification of Inspection Personnel

8.1.4.7 Term of Effectiveness

The qualification of an Inspector shall remain in effect indefinitely, provided the Inspector

- remains active in inspection of welded steel fabrication and
- their eye examinations are current,

unless there is specific reason to question the Inspector's ability.



Structural Welding Code—Steel 2020

175

Getting the Welds You Need

N4 INSPECTION AND NONDESTRUCTIVE TESTING PERSONNEL

N4.1 Quality Control Inspector Qualifications

N4.2 Quality Assurance Inspector Qualifications

N4.3 NDT Personnel Qualifications

**GLOSSARY**

**Quality control inspector (QCI).** Individual designated to perform quality control inspection tasks for the work being performed.

**Quality assurance inspector (QAI).** Individual designated to provide quality assurance inspection for the work being performed.



Specification for Structural Steel Buildings

176



Getting the Welds You Need Specification for Structural Steel Buildings

**N4 INSPECTION AND NONDESTRUCTIVE TESTING PERSONNEL**  
**N4.1 Quality Control Inspector Qualifications**

**QC** welding inspection personnel shall be qualified to the satisfaction of the fabricator's or erector's QC program, as applicable, and in accordance with either of the following:

- Associate welding inspectors (AWI) or higher as defined in *Standard for the Qualification of Welding Inspectors* (AWS B5.1), or
- Qualified under the provisions of AWS D1.1/D1.1M clause 6.1.4.

AWS B5.1:2013-AMD1  
An American National Standard



**Specification for the Qualification of Welding Inspectors**

AWS D1.1/D1.1M:2015  
An American National Standard



**Structural Welding Code—Steel**



177

Getting the Welds You Need Specification for Structural Steel Buildings

**N4 INSPECTION AND NONDESTRUCTIVE TESTING PERSONNEL**  
**N4.2 Quality Assurance Inspector Qualifications**

**QA** welding inspectors shall be qualified to the satisfaction of the QA agency's written practice, and in accordance with either of the following:

- Welding Inspectors (WIs), or Senior Welding Inspectors (SWIs), as defined in *Standard for the Qualification of Welding Inspectors* (AWS B5.1), except AWI are permitted to be used under the direct supervision of WI, who are on the premises and available when weld inspection is being conducted, or
- Qualified under the provisions of AWS D1.1/D1.1M clause 6.1.4.

AWS B5.1:2013-AMD1  
An American National Standard



**Specification for the Qualification of Welding Inspectors**

AWS D1.1/D1.1M:2015  
An American National Standard



**Structural Welding Code—Steel**



178

Getting the Welds You Need

- welding symbols
- joint details
- document submittals
- welding procedure specification (WPS) review
- inspection
- **nondestructive testing**







179

Getting the Welds You Need Specification for Structural Steel Buildings

**N5 MINIMUM REQUIREMENTS FOR INSPECTION OF STRUCTURAL STEEL BUILDINGS**  
**N5.5 Nondestructive Testing of Welded Joints**  
**N5.5a Procedures**

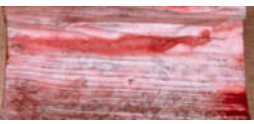
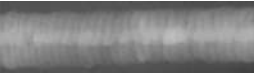
Ultrasonic testing (UT), magnetic particle testing (MT), penetrant testing (PT) and radiographic testing (RT), where required, shall be performed by QA in accordance with AWS D1.1/D1.1M.



180

Getting the Welds You Need

Visual Testing (after welding)		
Discontinuity	Ability	
Cracks	A	(1)
Laminations	A	(1,3)
Porosity	A	(1)
Overlap	O	
Undercut	A	
Inadequate joint preparation	U	
Incomplete fusion	U	
Slag Inclusions	U	

A - Applicable    O - Marginal    U - Generally Inapplicable  
 (1) Surface only    (3) Weld preparation or base edge



181

Getting the Welds You Want and Need

Penetrant Testing

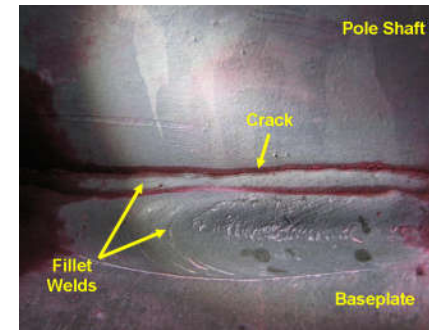

182

Getting the Welds You Need

Penetrant Testing		
Discontinuity	Ability	
Cracks	A	(1)
Laminations	A	(1,3)
Porosity	A	(1)
Overlap	A	
Undercut	O	
Inadequate joint preparation	U	
Incomplete fusion	U	
Slag Inclusions	U	

A - Applicable    O - Marginal    U - Generally Inapplicable  
 (1) Surface only    (3) Weld preparation or base edge



183

Getting the Welds You Need

Magnetic Particle Testing



184



Getting the Welds You Need

Magnetic Particle Testing		
Discontinuity	Ability	
Cracks	A	(2)
Laminations	A	(2,3)
Porosity	O	(2)
Overlap	A	
Undercut	O	
Inadequate joint preparation	U	
Incomplete fusion	U	
Slag Inclusions	O	(2)

A - Applicable    O - Marginal    U - Generally Inapplicable  
 (2) Surface and slightly subsurface    (3) Weld preparation or base edge



185



Getting the Welds You Need

Ultrasonic Testing		
Discontinuity	Ability	
Cracks	A	
Laminations	A	
Porosity	O	
Overlap	O	
Undercut	O	
Inadequate joint preparation	A	
Incomplete fusion	A	
Slag Inclusions	A	

A - Applicable    O - Marginal    U - Generally Inapplicable



187

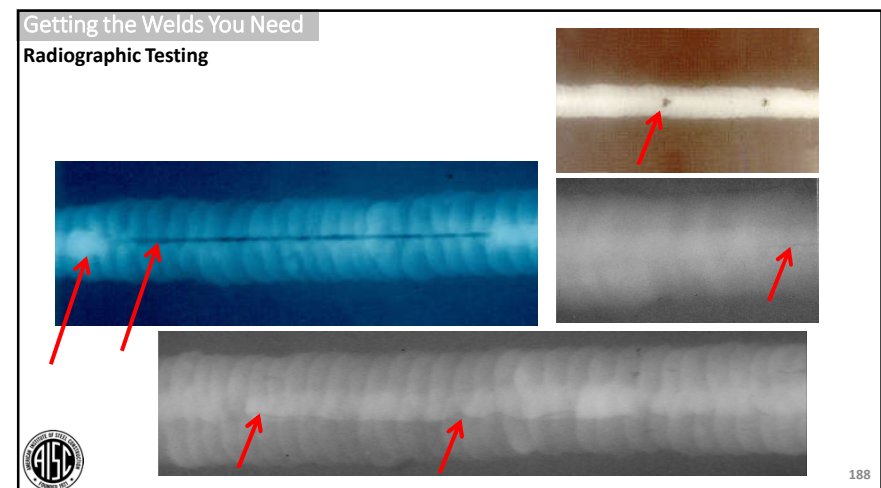

Getting the Welds You Need

Radiographic Testing	
Discontinuity	Ability
Cracks	O
Laminations	U
Porosity	A
Overlap	U
Undercut	A
Inadequate joint preparation	A
Incomplete fusion	O
Slag Inclusions	A
A - Applicable    O - Marginal    U - Generally Inapplicable	



189

Getting the Welds You Need

**8 Inspection**  
**Part D NDT Procedures**  
**8.15 Extent of Testing**

**8.15.1 Full Testing**  
Weld joints requiring testing by contract specification shall be tested for their full length, unless partial or spot testing is specified.

**8.15.2 Partial Testing**  
When partial testing is specified, the location and lengths of welds or categories of weld to be tested shall be clearly designated in the contract documents.

**8.15.3 Spot Testing**  
number of spots in each designated category of welded joint to be specified  
minimum spot test length 4 in. [100 mm]

- if passes, ok
- if fails, explore & test two more spots
- if fails, test entire segment of weld





190

Getting the Welds You Need

Specification for Structural Steel Buildings

**N5 MINIMUM REQUIREMENTS FOR INSPECTION OF STRUCTURAL STEEL BUILDINGS**  
**N5.5 Nondestructive Testing of Welded Joints**  
**N5.5b CJP Groove Weld NDT**

For structures in Risk Category III or IV, UT shall be performed by QA on all CJP groove welds subject to transversely applied tension loading in butt, T- and corner joints, in materials 5/16 in. [8 mm] thick or greater.

191

Getting the Welds You Need

Specification for Structural Steel Buildings

**N5 MINIMUM REQUIREMENTS FOR INSPECTION OF STRUCTURAL STEEL BUILDINGS**  
**N5.5 Nondestructive Testing of Welded Joints**  
**N5.5b CJP Groove Weld NDT**

For structures in Risk Category II, UT shall be performed by QA on 10% of CJP groove welds in butt, T- and corner joints subject to transversely applied tension loading, in materials 5/16 in. [8 mm] thick or greater.



192

Getting the Welds You Need

Specification for Structural Steel Buildings

**N5 MINIMUM REQUIREMENTS FOR INSPECTION OF STRUCTURAL STEEL BUILDINGS**

**N5.5 Nondestructive Testing of Welded Joints**

**N5.5c Welded Joints Subjected to Fatigue**

When required by Appendix 3, Table A-3.1, welded joints requiring weld soundness to be established by radiographic or ultrasonic inspection shall be tested by QA as prescribed.

Reduction in the rate of UT is prohibited.



193



Getting the Welds You Need

Structural Welding Code—Steel 2020

**4 Design of Welded Connections**

**Part C Specific Requirements for Design of Nontubular Connections**

**(Cyclically Loaded)**

**4.19 Inspection**

Fatigue categories B and C require that the **Engineer** ensure that CJP groove welds subject to **cyclic transverse applied stress into the tensile range** be inspected using Radiographic Testing (RT) or Ultrasonic Testing (UT).

194



Getting the Welds You Need

Specification for Structural Steel Buildings

**N5 MINIMUM REQUIREMENTS FOR INSPECTION OF STRUCTURAL STEEL BUILDINGS**

**N5.5 Nondestructive Testing of Welded Joints**

**N5.5e Reduction of Ultrasonic Testing Rate**

... The rate of UT is permitted to be reduced if approved by the **EOR** and the **AHJ**.

Where the initial rate for UT is 100%, the NDT rate for an individual welder or welding operator is permitted to be reduced to 25%, provided the rejection rate, the number of welds containing unacceptable defects divided by the number of welds completed, is demonstrated to be 5% or less of the welds tested for the welder or welding operator.

A sampling of at least 40 completed welds shall be made for such reduced evaluation on each project.

195



Getting the Welds You Need

Seismic Provisions for Structural Steel Buildings

**J6 WELDING INSPECTION AND NONDESTRUCTIVE TESTING**

**J6.2 NDT of Welded Joints**

In addition to the requirements of *Specification* Section N5.5, nondestructive testing of welded joints shall be as required in this section.

196



Getting the Welds You Need

**J6 WELDING INSPECTION AND NONDESTRUCTIVE TESTING**  
**J6.2 NDT of Welded Joints**  
**J6.2a CJP Groove Weld NDT**

Seismic Provisions for Structural Steel Buildings

Ultrasonic testing shall be performed on 100% of CJP groove welds in materials 5/16 in. [8 mm] thick or greater.

Ultrasonic testing in materials less than 5/16 in. [8 mm] thick is not required.

Magnetic particle testing shall be performed on 25% of all beam-to-column CJP groove welds.

**Exception:** For ordinary moment frames in risk categories I or II, UT and MT of CJP groove welds are required only for demand critical welds.





197

Getting the Welds You Need

**J6 WELDING INSPECTION AND NONDESTRUCTIVE TESTING**  
**J6.2 NDT of Welded Joints**  
**J6.2d Beam Cope and Access Hole NDT**

Seismic Provisions for Structural Steel Buildings

At welded splices and connections, thermally cut surfaces of beam copes and access holes shall be tested using magnetic particle testing or penetrant testing, when the flange thickness exceeds 1-1/2 in. [38 mm] in rolled shapes, or when the web thickness exceeds 1-1/2 in. [38 mm] for built-up shapes.

198

Getting the Welds You Need

**7 Inspection**  
**7.4 Wide-Flange k-Area Inspection**

Structural Welding Code—Seismic Supplement

When required by the QAP, MT of the member web shall be performed after welding of doubler plates, continuity plates or stiffeners in the k-area.

The member web area to be tested for cracks using MT shall include the k-area base metal within 3 in [75 mm] of the weld.

The MT shall be performed no sooner than 48 hours following completion of the welding.



199

Getting the Welds You Need

**8 Inspection**  
**Part D NDT Procedures**  
**8.14 Procedures**  
**8.14.6 Personnel Qualification**  
**8.14.6.1 ASNT Requirements**

Structural Welding Code—Steel 2020

Personnel performing NDT other than visual shall be qualified in conformance with the current edition of the American Society for Nondestructive Testing Recommended Practice No. SNT-TC-1A.

Individuals who perform NDT shall be qualified for:

- (1) NDT Level II, or
- (2) NDT Level I working under the NDT Level II



200

Getting the Welds You Need

Recommended Practice No. SNT-TC-1A      ANSI/ASNT Standard CP-189

[www.asnt.org](http://www.asnt.org)

201

Getting the Welds You Need

**8 Inspection**  
**Part F Ultrasonic Testing (UT) of Groove Welds**  
**8.19 General**  
**8.19.2 Variations**

Structural Welding Code—Steel 2020

Annex O and Annex H specify alternative ultrasonic techniques for performing conventional UT and phased array UT examination of groove welds.

Other variations in testing procedures, equipment, and acceptance standards not included in Part F of Clause 8 may be used with the approval of the Engineer.

Such variations include other thicknesses, weld geometries, transducer sizes, frequencies, couplant, painted surfaces, testing techniques, etc.

Such approved variations shall be recorded in the inspection records.

202

Getting the Welds You Need

**Annex H (Normative)**  
**Phased Array Ultrasonic Testing (PAUT)**

Structural Welding Code—Steel 2020

**H1. Introduction**  
This annex provides mandatory requirements that shall apply when phased array ultrasonic testing (PAUT) is used. The alternative techniques presented in this annex require written procedures, advanced personnel training and qualification, and calibration methods specific to PAUT.

**H2. Scope**  
The procedures and standards set forth in this annex govern PAUT examinations of groove welds, including heat-affected zones (HAZ), for thicknesses between 3/16 in and 8 in [5 mm and 200 mm] using encoded linear scanning. These procedures and standards exclude the PAUT examination of tubular T, Y, and K connection welds.

203

Getting the Welds You Need

**7 Inspection**  
**7.10 Ultrasonic Testing**  
**7.10.1 Technique**

Structural Welding Code—Seismic Supplement

Ultrasonic testing (UT) of welds required by the Quality Assurance Plan shall be performed according to the procedures prescribed in AWS D1.1/D1.1M Clause 6, Part F, following a written procedure containing the elements prescribed in AWS D1.1/D1.1M Clause Q3 of Annex Q, UT Examination of Welds by Alternative Techniques.

AWS D1.1/D1.1M Clause 6, Part F procedures shall be qualified using weld mock-ups having 1.5 mm diameter side drilled holes similar to Annex Q Figure Q.3 of AWS D1.1/D1.1M.

204



Getting the Welds You Need

**7 Inspection**  
**7.10 Ultrasonic Testing**  
**7.10.1 Technique**

**AWS D1.1 – Annex Q**  
**UT Examination of Welds by Alternative Techniques**

<b>Q3</b>	<b>UT Procedure</b>
Q4	UT Operator & Equipment
Q5	Reference Standard
Q6	Calibration Methods
Q7	Scanning
Q8	Weld Discontinuity Characterization Methods
Q9	Weld Discontinuity Sizing and Location Methods
Q10	Problems with Discontinuities
Q11	Discontinuity Amplitude Levels and Weld Classes Discontinuity Amplitude Levels
Q12	Acceptance / Rejection Criteria
Q13	Preparation and Disposition of Reports

Structural Welding Code—  
Seismic Supplement

205

Getting the Welds You Need

**7 Inspection**  
**7.2 Inspector Qualifications**  
**7.2.4 UT Technicians**

Ultrasonic testing (UT) for QA shall be performed only by UT technicians:

- (1) Certified as Level II or Level III by their employer, or
- (2) Certified as ASNT Level III through examination by the ASNT.

Structural Welding Code—  
Seismic Supplement

206

Getting the Welds You Need

**7 Inspection**  
**7.2 Inspector Qualifications**  
**7.2.4 UT Technicians**

**Annex F Supplemental Ultrasonic Technician Testing**

$D$  = detected flaws / number flaws  
 $F$  = false indications / total indications  
 $n$  = number of flaws

$$R = \frac{n - 2}{2(n - 1)} (1 + D - F)$$

$R_{min} = 80\%$

Structural Welding Code—  
Seismic Supplement

207

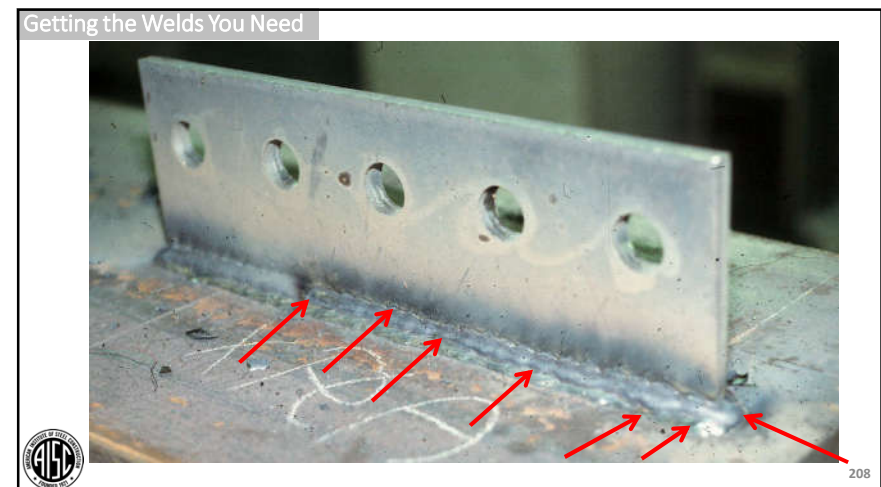

Getting the Welds You Need

Structural Welding Code—Steel 2020

**1 General Requirements**  
**1.5 Responsibilities**  
**1.5.1 Engineer's Responsibilities**

The Engineer shall be responsible for the development of the contract documents that govern products or structural assemblies produced under this code.

The **Engineer** may add to, delete from, or otherwise modify, the requirements of this code to meet the particular requirements of a specific structure.

All requirements that modify this code shall be incorporated into contract documents.

...



209

Getting the Welds You Need

Structural Welding Code—Steel 2020

**1 General Requirements**  
**1.5 Responsibilities**  
**1.5.1 Engineer's Responsibilities**

The Engineer shall specify in contract documents, as necessary, and as applicable, the following:

...

**(4) Weld acceptance criteria other than that specified in Clause 8.**

...



210

Getting the Welds You Need

Structural Welding Code—Steel 2020

**8 Inspection**  
**Part C Acceptance Criteria**  
**8.8 Engineer's Approval for Alternate Acceptance Criteria**

The fundamental premise of the Code is to provide general stipulations applicable to most situations.

Acceptance criteria for production welds different from those described in the Code may be used for a particular application, provided they are suitably documented by the proposer and approved by the **Engineer**.

These alternate acceptance criteria can be based upon evaluation of suitability of service using past experience, experimental evidence or engineering analysis considering material type, service load effects, and environmental factors.



211

Getting the Welds You Need

Structural Welding Code—Steel 2020

**8 Inspection**  
**Part C Acceptance Criteria**  
**C8.8 Engineer's Approval for Alternate Acceptance Criteria**

The criteria provided in section 7, Fabrication, of the Code are based upon knowledgeable judgement of what is achievable by a qualified welder.

The criteria in section 7 should not be considered as a boundary of suitability for service. Suitability for service analysis would lead to widely varying workmanship criteria unsuitable for a standard code.

Furthermore, in some cases, the criteria would be more liberal than what is desirable and producible by a qualified welder.

...



212



Getting the Welds You Need

**8 Inspection**  
**Part C Acceptance Criteria**  
**C8.8 Engineer's Approval for Alternate Acceptance Criteria**

...

In general, the appropriate quality acceptance criteria and whether a deviation produces a harmful product should be the Engineer's decision.

When modifications are approved, evaluation of suitability for service using modern fracture mechanics techniques, a history of satisfactory service in similar structures, or experimental evidence is recognized as a suitable basis for alternate acceptance criteria for welds.



Structural Welding Code—Steel 2020

213

Getting the Welds You Need



BRITISH STANDARD

**BS 7910**

**Guide on methods for assessing the acceptability of flaws in metallic structures**

Fitness-For-Service

**API 579-1**  
**ASME FFS-1**



214

Getting the Welds You Need

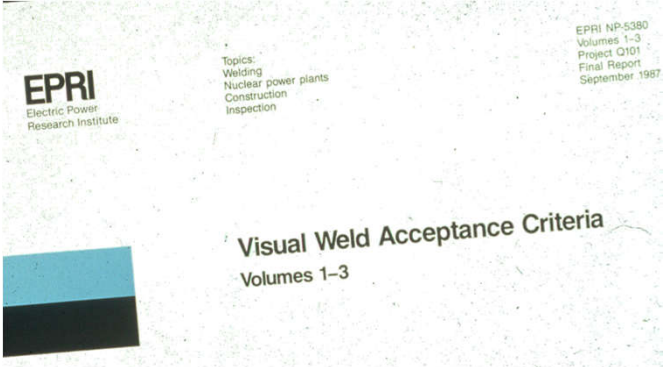

EPRI  
Electric Power  
Research Institute

Topics:  
Welding  
Nuclear power plants  
Construction  
Inspection

EPRI NP-5380  
Volumes 1-3  
Project Q101  
Final Report  
September 1987

**Visual Weld Acceptance Criteria**  
Volumes 1-3



**EPRI NP-5380**  
[https://www.epri.com/#/pages/product/NP-5380-V1-V3\(SET\)?lang=en](https://www.epri.com/#/pages/product/NP-5380-V1-V3(SET)?lang=en)

215

Getting the Welds You Need

- **welding symbols**
- **joint details**
- **document submittals**
- **welding procedure specification (WPS) review**
- **inspection**
- **nondestructive testing**



216

Getting the Welds You Need

**Engineers**

- Start with *AISC 360* (and *AISC 341* and *AISC 358*, if seismic) .... then look at *AWS D1* Structural Welding Codes
- Make sure your contract documents satisfy *AISC 303*
- Write project specifications for the specific project – don't use a "collection" from previous projects with excessive req'ts
- Seek advice from prospective fabricators and erectors, or use a welding consultant, to review your project specifications and your welded connections during design development
- Listen to the suggestions from your fabricator and erector
- Consider using a welding consultant to assist with difficult welded details, reviewing WPS submittals, responding to complex RFIs, addressing nonconformances



217

Getting the Welds You Need

**Fabricators and Erectors**

- Review your Quality Management System, including procedures and personnel, regarding the project
- Review project specifications and design documents thoroughly, repeat
- Review complex welded connections, plan your assembly sequence, and be proactive in suggesting improvements to the details to the Engineer
- Make sure you have and use experienced welding supervision, not leaving the assembly sequence and details to the welders and welding operators alone
- Remember, the Code contains minimum requirements, and you may need to do more
- Consider using a welding consultant to assist with difficult welded details, reviewing WPSs prior to submittal, submitting complex RFIs, and addressing nonconformances and repairs



218

Getting the Welds You Need



AISC Regional Engineer Staff Meeting, 1982



AISC Associate Director of Education  
1986 - 1990



219

Getting the Welds You Need

**Getting the Welds You Need**



Robert E. Shaw, Jr., PE  
President  
Steel Structures Technology Center, Inc.  
Howell, Michigan

AISC | Questions?



Smarter.  
Stronger.  
Steel.

## PDH Certificates

---

- You will receive an email on how to report attendance from: [registration@aisc.org](mailto:registration@aisc.org).
- Be on the lookout: Check your spam filter! Check your junk folder!
- Completely fill out online form. Don't forget to check the boxes next to each attendee's name!



## PDH Certificates

---

- Reporting site (URL will be provided in the forthcoming email).
- Username: Same as AISC website username.
- Password: Same as AISC website password.



AISC | Thank you

