

There's always a solution in steel.

## AISC Live Webinars

Thank you for joining our live webinar today.  
We will begin shortly. Please standby.

Thank you.

Need Help?  
Call ReadyTalk Support: 800.843.9166



## AISC Live Webinars

Today's audio will be broadcast through the internet.

Alternatively, to hear the audio through the phone, dial:  
(866) 519-2796                      Passcode: 638011



There's always a solution in steel!

## AISC Live Webinars

Today's live webinar will begin shortly. Please stand by.

As a reminder, all lines have been muted. Please type any questions or comments through the Chat feature on the left portion of your screen.

Today's audio will be broadcast through the internet.  
Alternatively, to hear the audio through the phone, dial:

(866) 519-2796                      Passcode: 638011



There's always a solution in steel!

## AISC Live Webinars

AISC is a Registered Provider with The American Institute of Architects Continuing Education Systems (AIA/CES). Credit(s) earned on completion of this program will be reported to AIA/CES for AIA members. Certificates of Completion for both AIA members and non-AIA members are available upon request.

This program is registered with AIA/CES for continuing professional education. As such, it does not include content that may be deemed or construed to be an approval or endorsement by the AIA of any material of construction or any method or manner of handling, using, distributing, or dealing in any material or product.

Questions related to specific materials, methods, and services will be addressed at the conclusion of this presentation.



There's always a solution in steel!



## AISC Live Webinars

### Copyright Materials

This presentation is protected by US and International Copyright laws. Reproduction, distribution, display and use of the presentation without written permission of AISC is prohibited.

© The American Institute of Steel Construction 2017

The information presented herein is based on recognized engineering principles and is for general information only. While it is believed to be accurate, this information should not be applied to any specific application without competent professional examination and verification by a licensed professional engineer. Anyone making use of this information assumes all liability arising from such use.



There's always a solution in steel!

## Course Description

### Session L3: Effects of Curvature and Skew

October 26, 2017

This session will address the behavior, analysis, and construction of curved and skewed steel I-girder bridges. The session will begin with a discussion of how steel I-girders and their connecting cross-frames fit together during erection, which will establish the framework for the class. Then the behavior of curved and skewed steel I-girder bridges will be reviewed, with an emphasis on behaviors unique to these types of structures (torsional stresses and deformations, global overturning, etc.). Various analysis methods for curved and skewed steel I-girder bridges will be described and compared, including 1D, 2D, and 3D analysis methods. The effects of boundary conditions, span length, curvature, and skew will also be presented. The session will then transition to a discussion of the fabrication and erection processes associated with fit, including fabrication detailing, girder and cross frame fabrication, and girder and cross frame erection practices.



There's always a solution in steel!

## Learning Objectives

- Become familiar with curved and skewed steel I-girder bridges, from analysis to construction.
- Gain an understanding of the behavior unique to these types of structures including torsional stresses, torsional deformation, global overturning and more.
- Become familiar with analysis methods that are appropriate for curved and skewed steel I-girder bridges.
- Gain an understanding of the fabrication and erection processes associated with fit for curved and skewed steel I-girder bridges.



There's always a solution in steel!

## Introduction to Steel Bridge Design

Session L3: Effects of Curvature and Skew



Presented by

Domenic Coletti, PE  
HDR  
Raleigh, NC



Ronnie Medlock, PE  
High Steel  
Lancaster, PA

There's always a solution in steel.



There's always a solution in steel.

### Introduction to Steel Bridge Design

Session L3: Effects of Curvature and Skew





Domenic Coletti, PE  
HDR – Raleigh, NC



### Introduction to Steel Bridge Design

- R1: Introduction to Bridge Engineering
- R2: Introduction and History of AASHTO LRFD Bridge Design Specifications
- R3: Steel Material Properties
- R4: Loads and Analysis
  
- L1: [Steel Bridge Fabrication](#)
- L2: [Plate Girder Design and Stability](#)
- **L3: [Effects of Curvature and Skew](#)**
- L4: [Fatigue and Fracture Design](#)

---





10

### Session L3

- **Effects of Curvature and Skew**
  - Behavior Considerations
  - Analysis Topics
    - Analysis Methods (1D, 2D, 3D)
    - Boundary Conditions
    - Magnitude of Span Length, Curvature and Skew
  - Erection of Curved and/or Skewed Steel I-Girder Bridges → Cross-Frame Fit

---





11

### Why?

- **What is a curved girder bridge, and why is it curved?**
- **What is a skewed bridge, and why is it skewed?**

---



12



## Why?

- Curved girder bridges



13

## Why?

- Curved girder bridges



14

## Why?

- Skewed bridges



15

## Behavior Considerations

- Overview

- The Basics
- Torsion: Stresses
- Torsion: Deformations
- Curved Girder Load Shifting
- Curved Girder Flange Lateral Bending
- Effects of Skew



16

## Behavior Considerations

- The Basics
  - Shear
  - Moment
  - Vertical Deflection



17

## Behavior Considerations

- Torsion: Stresses in I-Girders
  - St. Venant Torsion
  - Warping Torsion

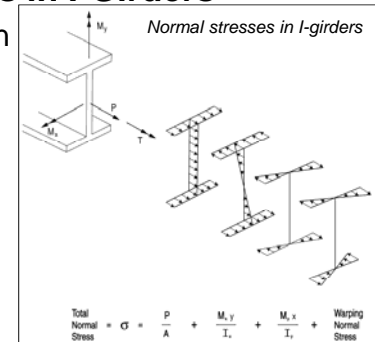

$$\text{Total Normal Stress} = \sigma = \frac{P}{A} + \frac{M_y}{I_x} + \frac{M_x}{I_y} + \text{Warping Normal Stress}$$



18

## Behavior Considerations

- Torsion: Stresses in I-Girders
  - St. Venant Torsion
  - Warping Torsion

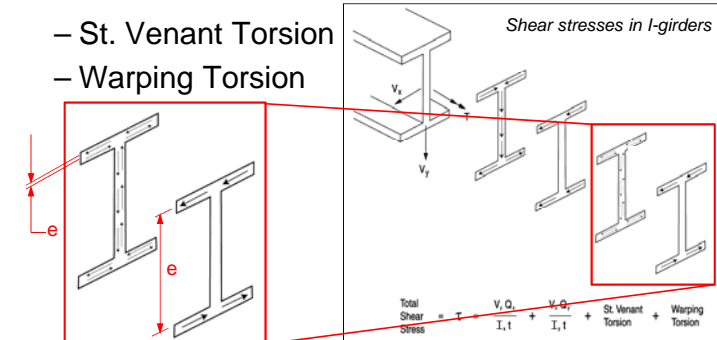

$$\text{Total Shear Stress} = \tau = \frac{V_y Q_x}{I_x I_t} + \frac{V_x Q_y}{I_y I_t} + \text{St. Venant Torsion} + \text{Warping Torsion}$$



19

## Behavior Considerations

- Torsion: Stresses in Box Girders
  - St. Venant Torsion
  - Warping Torsion

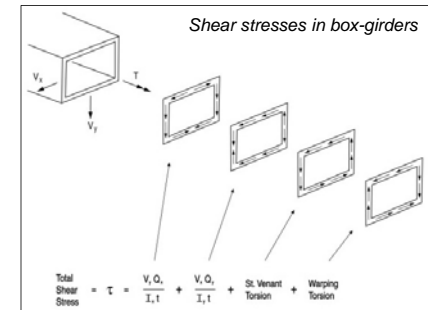

$$\text{Total Shear Stress} = \tau = \frac{V_y Q_x}{I_x I_t} + \frac{V_x Q_y}{I_y I_t} + \text{St. Venant Torsion} + \text{Warping Torsion}$$



20

## Behavior Considerations

- **Torsion: Stresses in Box Girders**

- St. Venant Torsion
- Warping Torsion

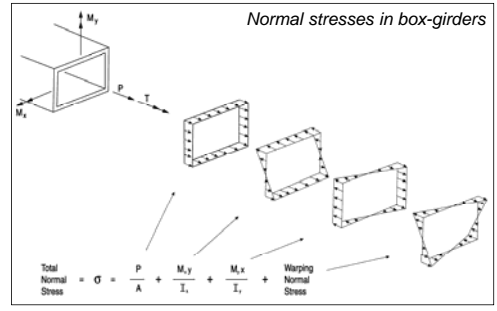

## Behavior Considerations

- **Torsion: Deformations**

- Twisting
- Warping
- Deformations affect fit-up

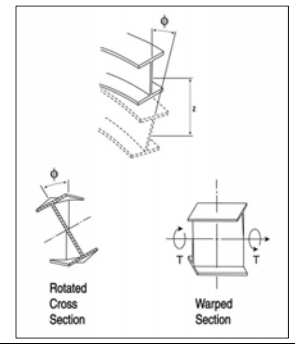

## Behavior Considerations

- **Curved Girder Load Shifting**

- CG offset from chord line between supports
- Girders on outside of curve carry more load
- Load is transferred through cross-frames

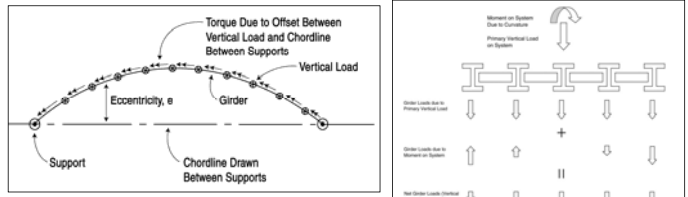

## Behavior Considerations

- **Curved Girder Response to Torsion**

- Radial flange load

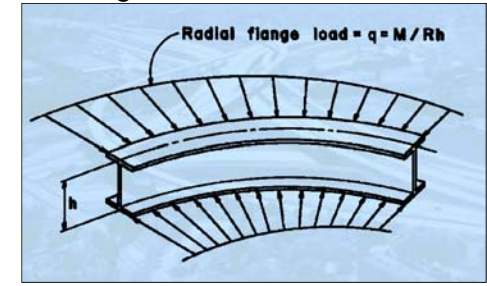

## Behavior Considerations

- **Curved Girder Response to Torsion**
  - Changes in vertical moment

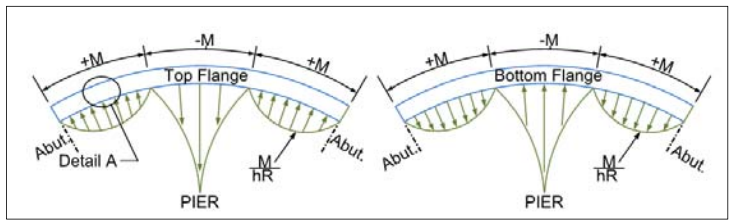

## Behavior Considerations

- **Curved Girder Response to Torsion**
  - Flange Lateral Bending
  - Cross-Frame Forces

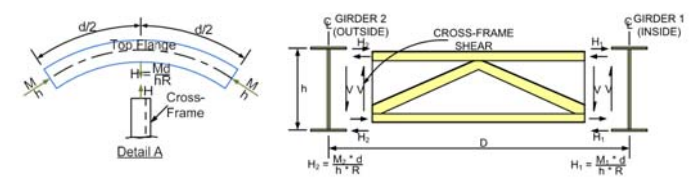

## Behavior Considerations

- **Curved Girder Response to Torsion**

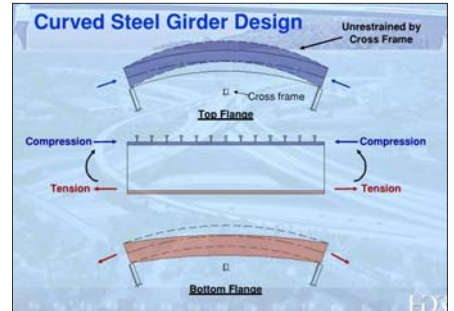

## Behavior Considerations

- **Curved Girder Response to Torsion**

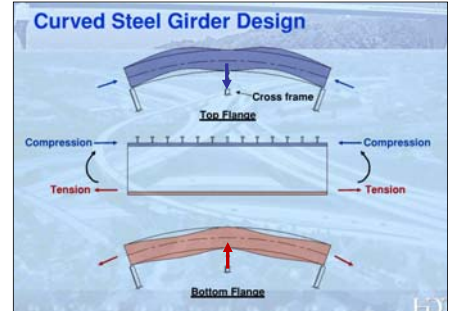

## Behavior Considerations

- **Effects of Skew**

- Depends on magnitude of skew and type of framing

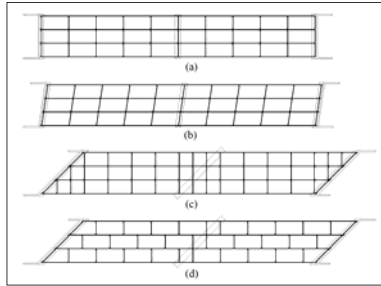

Plan views of framing plans for straight steel I-girder bridges



29

## Behavior Considerations

- **Effects of Skew**

- Non-skewed cross-frames

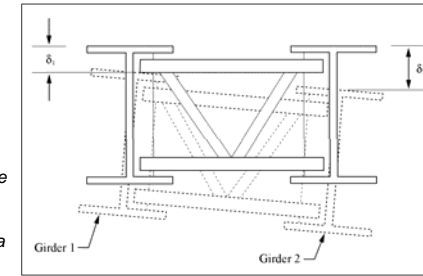
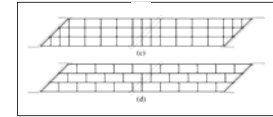

Superstructure cross-section showing steel I-girders and a cross-frame



30

## Behavior Considerations

- **Effects of Skew**

- Skewed cross-frames

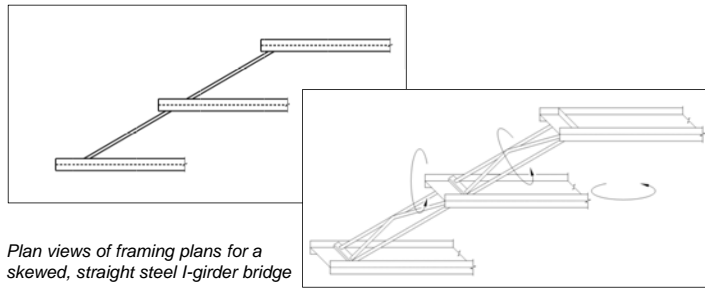
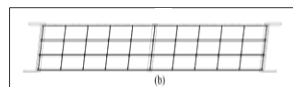

Plan views of framing plans for a skewed, straight steel I-girder bridge



31

## Behavior Considerations

- **Effects of Skew**

- “Nuisance Stiffness” effect

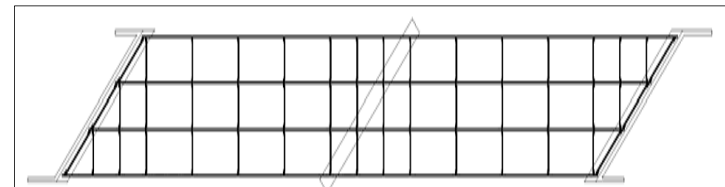

Plan view of a framing plan for a skewed, straight steel I-girder bridge



32

## Behavior Considerations

- **Effects of Skew**
  - “Nuisance Stiffness” effect

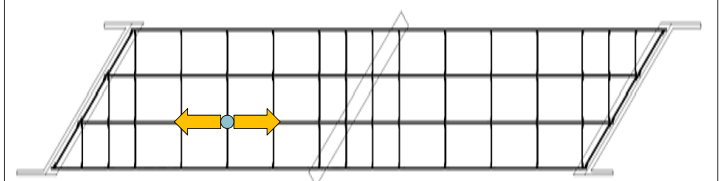

Plan view of a framing plan for a skewed, straight steel I-girder bridge



33

## Behavior Considerations

- **Effects of Skew**
  - “Nuisance Stiffness” effect

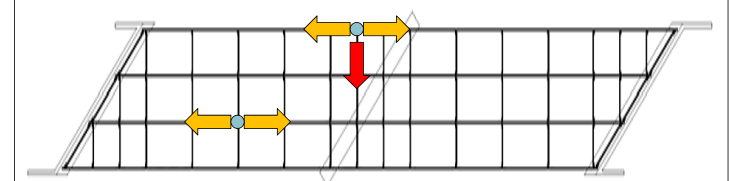

Plan view of a framing plan for a skewed, straight steel I-girder bridge



34

## Behavior Considerations

- **Effects of Skew**
  - “Nuisance Stiffness” effect

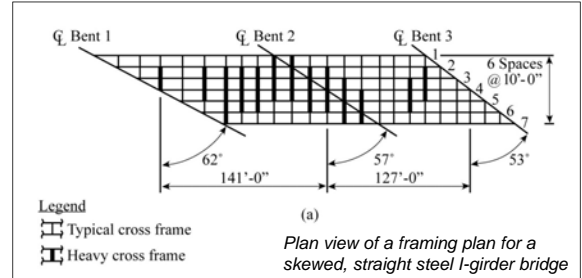

Plan view of a framing plan for a skewed, straight steel I-girder bridge



35

## Behavior Considerations

- **Effects of Skew**
  - “Nuisance Stiffness” effect

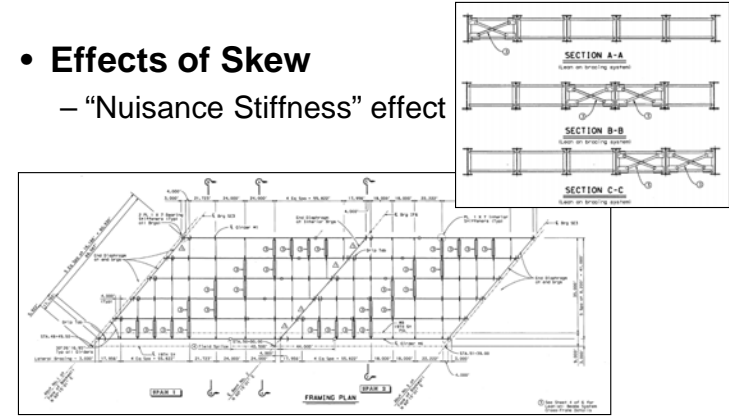

36



## Behavior Considerations

- **Effects of Skew**
  - “Nuisance Stiffness” effect



37

## Presentation Poll 1

Curved girders generally experience torsion:

- a. In all cases
- b. In some cases
- c. In few or no cases



38

## Presentation Poll 2

Straight girders generally experience torsion:

- a. In all cases
- b. In some cases
- c. In few or no cases



39

## Analysis Topics

- **Analysis Methods (1D, 2D, 3D)**
- **Boundary Conditions**



40

## Analysis Methods

- 1D Analysis
- 2D Analysis
- 3D Analysis

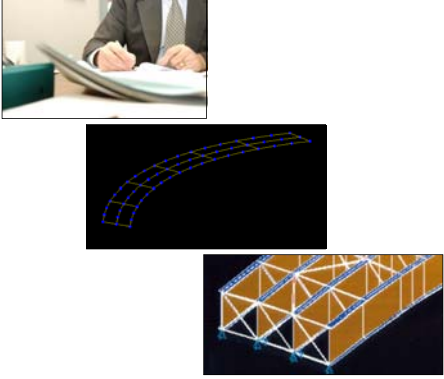

41

## Analysis Methods

- 1D Analysis
- 2D Analysis
- 3D Analysis

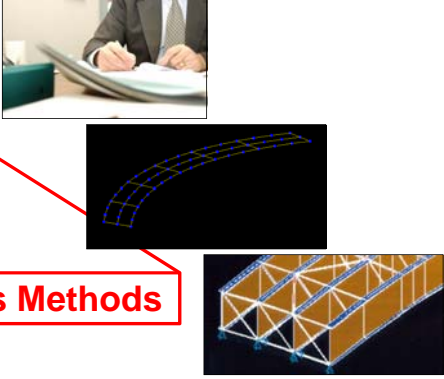

**Refined Analysis Methods**



42

## Analysis Methods

- **Issues**
  - Level of modeling refinement
  - Level of modeling effort
  - Amount of output
  - Live load modeling



43

## Analysis Methods

- **Live Load Modeling**
  - Multiple live load cases (“live load generator”)
  - Influence surface approach

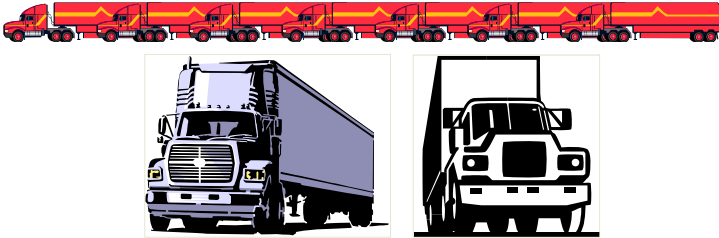

44

## Analysis Methods

- **1D Analysis (Approximate Analysis)**
  - Line Girder + Factors
  - V-Load Method: I-Girders
  - M/R Method: Tub Girders



45

## Analysis Methods

- **Line Girder + Factors**
  - Any line girder analysis tool can be used
  - Factors – FHWA “Curved Girder Workshop”
  - Approximate! Good for preliminary design

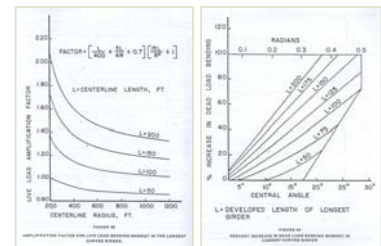

46

## Analysis Methods

- **V-Load Method (Curved I-Girders)**
  - Developed by USS in 1960s
  - “V-Loads” are the shears in cross-frames
  - Computer tools available

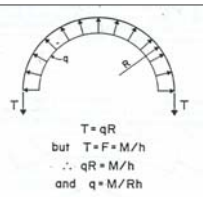
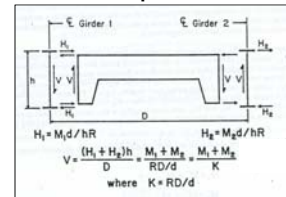

47

## Analysis Methods

- **M/R Method (Curved Box Girders)**
  - Developed by Tung and Fountain in 1970
  - Analogous to V-Load
  - Very cumbersome for multiple girder systems

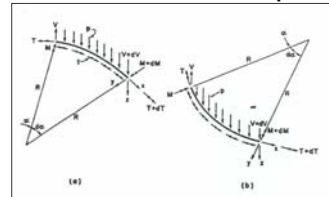

48



## Analysis Methods

- **2D Analysis Methods**
  - 2D Grid Analysis
  - 2D Plate & Eccentric Beam Analysis

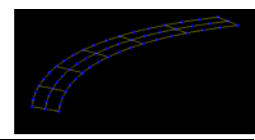

49

## Analysis Methods

- **2D Grid Analysis**
  - Girders modeled as line elements
  - Cross-frames modeled as line elements
  - Deck modeled in strips as line elements

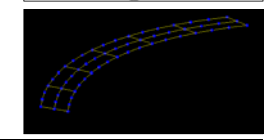
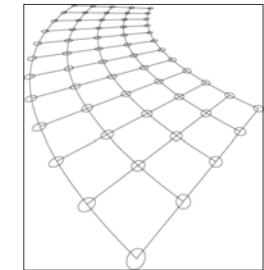

50

## Analysis Methods

- **2D Plate & Eccentric Beam Analysis**
  - Variant of 2D grid analysis
  - Deck modeled with plate or shell elements

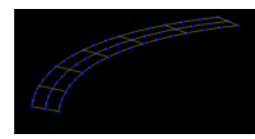
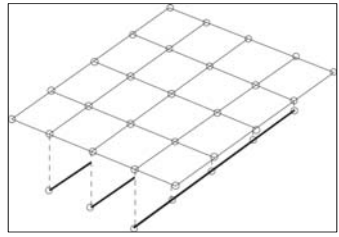

51

## Analysis Methods

- **2D Analysis Methods – Advantages**
  - Simple modeling
  - Efficient (level of modeling effort)
  - Some find it easier to understand
  - Computer tools readily available

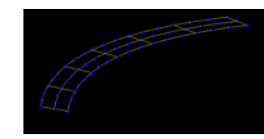

52



## Analysis Methods

- **2D Analysis Methods – Disadvantages**
  - I-Girder torsional stiffness modeling
  - Diaphragm stiffness modeling
  - Deck modeling
  - Live load distribution
  - In sum: Accuracy questions?

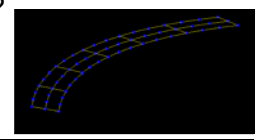

53

## Analysis Methods

- **2D Analysis Methods – Limitations**
  - Severe curvature and/or skew
  - Deep girders
  - Long spans
  - Variable depth girders

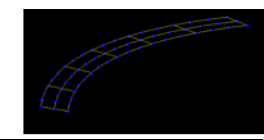

54

## Analysis Methods

- **3D Analysis Methods**
  - Flanges: beam or plate elements
  - Webs: plate elements
  - Cross-frames, bracing: truss or plate elements
  - Deck: solid or plate elements

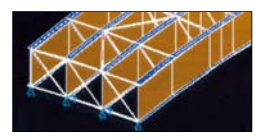

55

## Analysis Methods

- **3D Analysis Methods – Advantages**
  - All pieces and parts modeled - rigorous
  - Direct analysis results for all pieces and parts
  - Greater refinement
  - Greater accuracy (?)

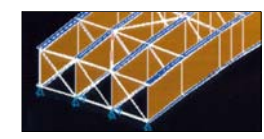

56



## Analysis Methods

- **3D Analysis Methods – Disadvantages**
  - Greater modeling effort
  - More complicated model
  - Results less “intuitive”
  - In sum: Is the refinement worth the effort?

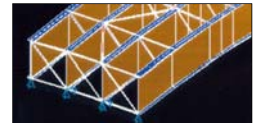

57

## Analysis Methods

- **3D Analysis Methods – Limitations**
  - Virtually no limitations on type or complexity of structures that can be modeled
  - Limitations come down to time, money, and experience/confidence with complex analysis

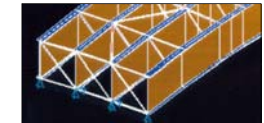

58

## Analysis Methods

- **Which should you use?**
  - “It depends...”
  - Analysis method should be appropriate for the complexity of the bridge

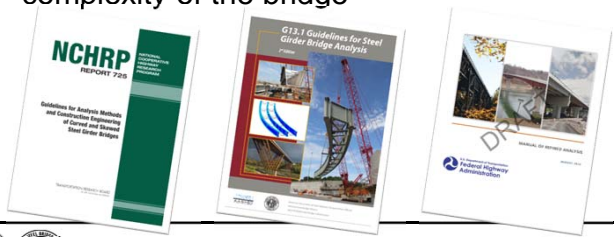

59

## Presentation Poll 3

- What is an appropriate analysis method for the final design of a straight 2-span bridge, 150'-150' spans, and a 12 degree skew?
- Line Girder Analysis
  - Line Girder + Factors Analysis
  - 2D Grid
  - Answers a and b
  - Answers a and c



60



## Boundary Conditions

- **Rollers vs. Pins**

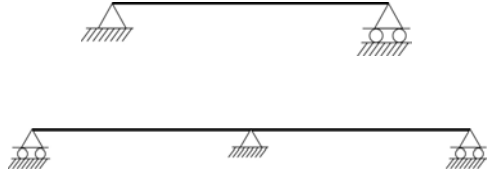

61

## Boundary Conditions

- **Simply supported beam**
  - One pin and one roller at neutral axis

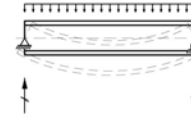

*Model and deflected shape*



*Moment diagram*



62

## Boundary Conditions

- **Simply supported beam**
  - One pin and one roller at bottom flange

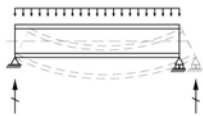

*Model and deflected shape*



*Moment diagram*



63

## Boundary Conditions

- **Simply supported beam**
  - Two pins at neutral axis

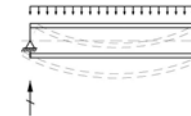

*Model and deflected shape*



*Moment diagram*



64

## Boundary Conditions

- **Simply supported beam**
  - Two pins at bottom flange

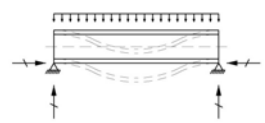

*Model and deflected shape*



*Moment diagram*



65

## Boundary Conditions

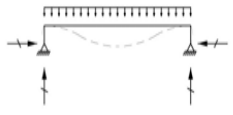
- **Simply supported beam**
  - Rigid frame analogy



*Model and deflected shape*





*Moment diagram*

66

## Boundary Conditions

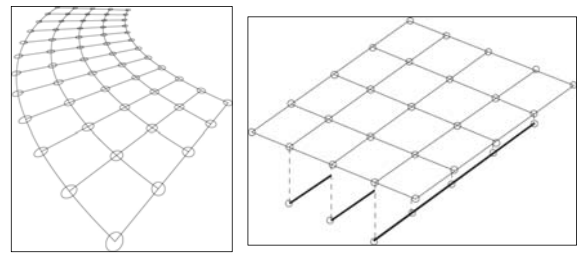







- **2D Grid Model vs. 2D Plate & Eccentric Beam Model**

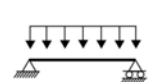
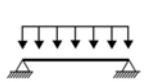
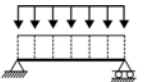
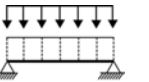

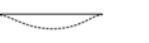

67

## Boundary Conditions

- **Effects of Various Boundary Conditions**

MODEL				
DEFLECTED SHAPE				
MOMENT DIAGRAM				
	<span style="font-size: 2em;">}</span>		<span style="font-size: 2em;">}</span>	
	BEAM OR GRID ANALYSIS		PLATE AND ECCENTRIC BEAM ANALYSIS	

68

## Boundary Conditions

- **Effects of Various Boundary Conditions**
  - Study in a design project
  - 2-span curved steel plate girder
  - 225' – 225' spans
  - Composite moments varied up to **5%**
  - Composite DL deflections varied up to **5%**
  - Composite LL deflections varied up to **31%**



69

## Boundary Conditions

- **Substructure Stiffness Effects**

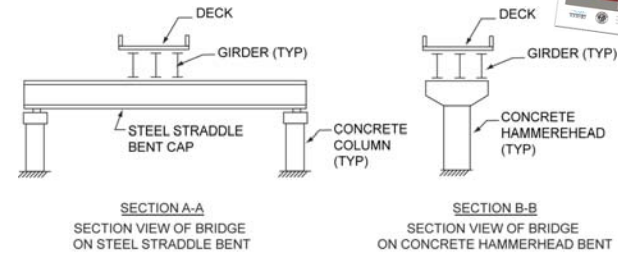

70

### Introduction to Steel Bridge Design

Session L3: Effects of Curvature and Skew



Ronnie Medlock, PE  
 High Steel, Lancaster, PA

There's always a solution in steel.



## Fit Considerations

- **What is fit**
- **Differential Deflections**
- **Fit Conditions**
  - No Load fit
  - Steel Dead Load Fit
  - Full Dead Load Fit
- **Fit impact on erection**
  - Straight, Skewed Bridges
  - Curved Bridges



72



## What is fit?

- As bridges deflect, there are subtle changes in the relationship of the bridge parts. Hence, bridge part may not fit the same way in various deflection conditions. Choices must be made about when the bridge parts should fit. The fit decision will impact erection and internal stresses associated with changing conditions.



73

## What is fit?

- I-girders on straight, skewed bridges can be fit to final dead load or to steel dead load

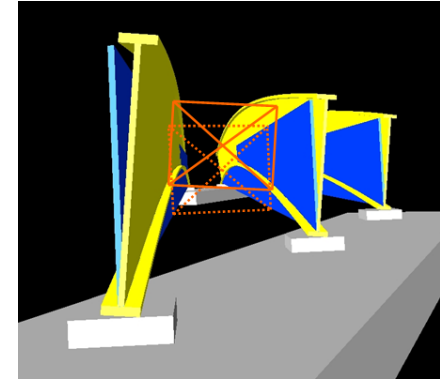

74

## Flexibility

- I-girders on straight, skewed bridges can be fit to final dead load due to flexibility in the girder
- Curved bridges are stiffer and do not fit well in final dead load fit



75

## Given Condition at a Discrete Cross Frame with Differential Deflections

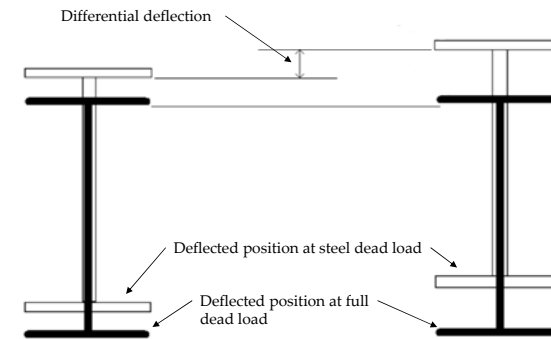

76



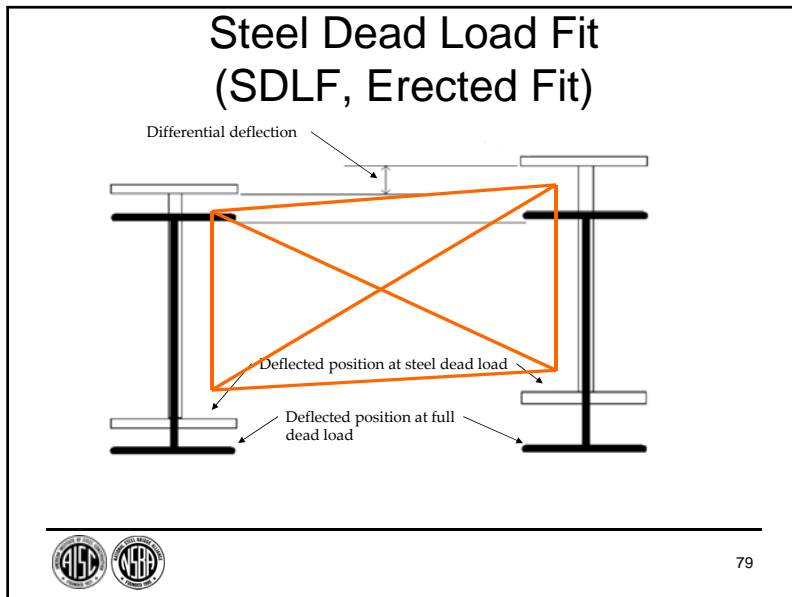
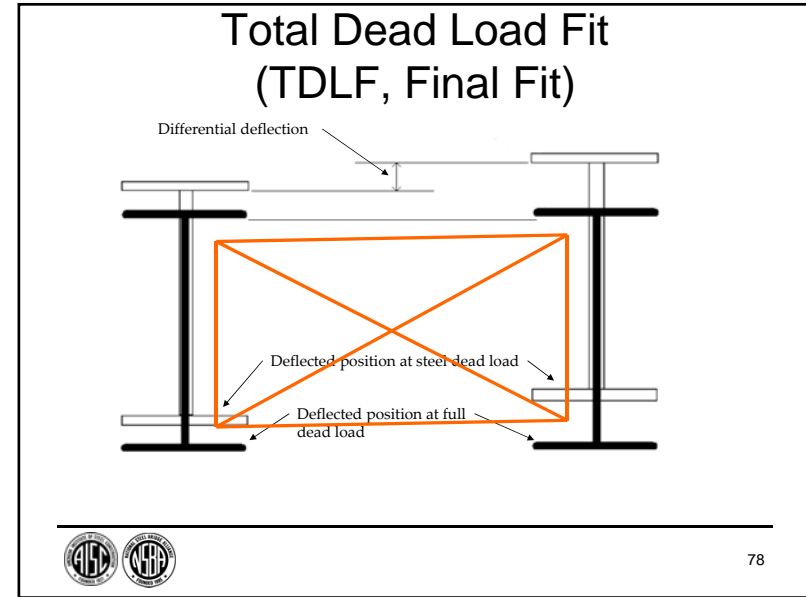
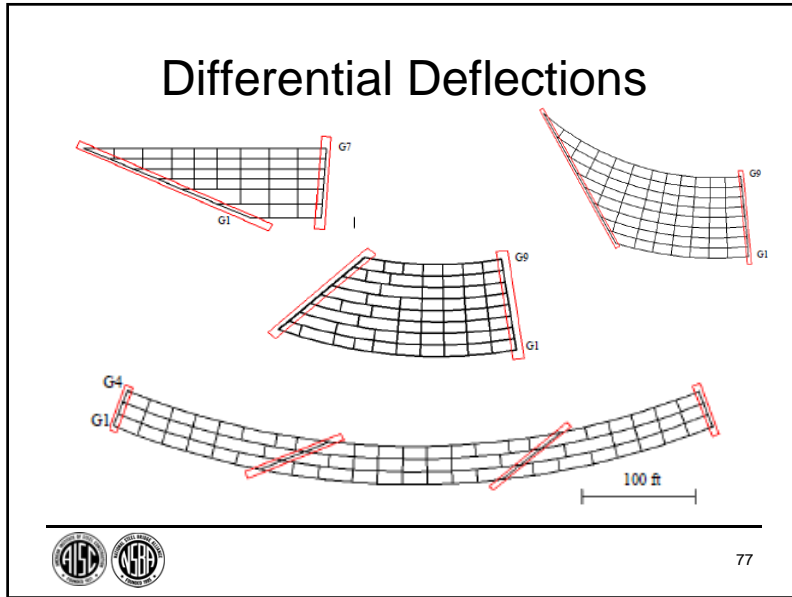

### Fit Conditions

	Useful	Avoid	Description
No-load fit	Fully Cambered Fit		Cross frames are detailed such that they fit when the girders are in the no-load condition
Steel Dead Load Fit	Erected Fit	Plumb at erection	Cross frames are detailed such that they fit when the girders are erected and under the weight of the erected steel only
Total Dead Load Fit	Final Fit	Plumb after all dead loads are in placed	Cross frames are detailed such that they fit when the girders are erected and all dead loads (deck, barrier, etc.) are present

80

## Practices for Fit Choice

- Fabricators follow the plans
- Skewed bridges
  - Sometimes total dead load fit
  - Sometimes steel dead load fit
- Curved bridges
  - “Always” steel dead load fit
- “Complex” structures
  - Generally steel dead load fit
- AASHTO requires the engineer to designate the fit condition
- Some owners have prescribed practices



## Fit Decision Goals

- Achieve erection
- Limit bearing rotation demands
- Facilitate joint alignment and bearing alignment
- On curved bridges, to limit the magnitude of additive locked-in dead load force effects



TABLE 2 - RECOMMENDED FIT CONDITIONS FOR STRAIGHT I-GIRDER BRIDGES  
 (INCLUDING CURVED I-GIRDER BRIDGES WITH L/R IN ALL SPANS  $\leq 0.03$  +/-)

Square Bridges and Skewed Bridges up to 20 deg +/- Skew			
	Recommended	Acceptable	Avoid
Any span length	Any		None
Skewed Bridges with skew > 20 deg +/- and $I_s \leq 0.30$ +/-			
	Recommended	Acceptable	Avoid
Any span length	TDLF or SDLF		NLF
Skewed Bridges with skew > 20 deg +/- and $I_s > 0.30$ +/-			
	Recommended	Acceptable	Avoid
Span lengths up to 200' +/-	SDLF	TDLF	NLF
Span lengths greater than 200' +/-	SDLF		TDLF & NLF

Reference: “Skewed and Curved I-girder Bridge Fit”, NSBA, August 2014

$$I_s = \frac{w_g \tan \theta}{L}$$



## Erection of Skewed Girder Bridges

- Detailed to Steel Dead Load Fit
  - Steel tends to go together readily
  - Girders are “plumb” at erection
  - Girders have some final lay over?
- Detailed to Full Dead Load Fit
  - Steel may have to be “forced together” (by, say, come along)
  - Girders are “laying over” at erection
  - Girders are “plumb” in final condition



TABLE 3 - RECOMMENDED FIT CONDITIONS FOR HORIZONTALLY CURVED I-GIRDER BRIDGES  
 ( $(L/R)_{MAX} > 0.03$  +/-)

Radial or Skewed Supports			
	Recommended	Acceptable	Avoid
Span lengths greater than 250' +/- and $L/R > 0.1$ +/-	NLF	SDLF	TDLF
All other cases	SDLF	NLF	TDLF

The recommendation of SDLF up to about 250' is based on many years of practice: use of SDLF has been almost universal for long span curved I-girder bridges like direct connectors and curved ramps in the United States. The recommendation transitions to NLF above this length because a limited study of these bridges shows cross frame forces can become significant as spans get longer and radii get smaller. NLF matches the normal analysis methods used in the design and will provide a better match between predicted forces and displacements than SDLF when the steel dead load displacements become large.

Reference: "Skewed and Curved I-girder Bridge Fit", NSBA, August 2014



## Erection of Curve Girder Bridges

- Detailed to Steel Dead Load Fit
  - Customary
  - Experience demonstrates steel goes together readily
- Detailed to Total Deal Load Fit
  - Can work, but can also lead to constructability issues: best to avoid
- Detailed to No Load Fit
  - May want to consider for long span curved structures



## Presentation Poll 4

What fit conditions are recommended for straight, skewed bridges?

- Total dead load fit
- Steel dead load fit
- No load fit



## Presentation Poll 5

What fit condition should be avoided on curved bridges?

- Total dead load fit
- Steel dead load fit
- No load fit



## Session L3 Recap

- **Effects of Curvature and Skew**
  - Behavior Considerations
  - Analysis Topics
    - Analysis Methods (1D, 2D, 3D)
    - Boundary Conditions
  - Erection of Curved and/or Skewed Steel I-Girder Bridges → Cross-Frame Fit



89

## Questions?



90

## Individual Webinar Registrants CEU/PDH Certificates

Within 2 business days...

- You will receive an email on how to report attendance from: [registration@aisc.org](mailto:registration@aisc.org).
- Be on the lookout: Check your spam filter! Check your junk folder!
- Completely fill out online form. Don't forget to check the boxes next to each attendee's name!



There's always a solution in steel!

## Individual Webinar Registrants CEU/PDH Certificates

Within 2 business days...

- Reporting site (URL will be provided in the forthcoming email).
- Username: Same as AISC website username.
- Password: Same as AISC website password.



There's always a solution in steel!



## 8-Session Registrants CEU/PDH Certificates

One certificate will be issued at the conclusion of all 8 sessions.



There's always a solution in steel!

## 8-Session Package Registrants Course Resources

1. Log on to your AISC account and go to Course Resources.  
<https://www.aisc.org/myaisc/course-resources/>
2. Locate your course.
3. Access handouts, videos, quizzes, quiz scores and attendance records.

aisc > myaisc > course resources > steel bridge design

### Steel Bridge Design

#### 8-SESSION PACKAGE RESOURCES

Event	Date	Handouts	Video	Quiz	Attendance
R1: Introduction To Bridge Engineering	N/A	<a href="#">Handouts</a>	<a href="#">Video</a> Parade R2N1L41	<a href="#">Pass</a> Score: 80	N/A
R2: Introduction and History of AASHTO Bridge Design	N/A	<a href="#">Handouts</a>	Available 9/11/2017 5:00 PM EDT	Available 9/11/2017 5:00 PM EDT	N/A
R3: Steel Material Properties	N/A	<a href="#">Handouts</a>	Available 9/11/2017 5:00 PM EDT	Available 9/11/2017 5:00 PM EDT	N/A
R4: Loads and Analysis	N/A	<a href="#">Handouts</a>	Available 9/11/2017 5:00 PM EDT	Available 9/11/2017 5:00 PM EDT	N/A
L1: Steel Bridge Fabrication	Oct 11 2017 1:30PM EDT	<a href="#">Handouts</a>	Available 10/14/2017 5:00PM EDT	Available 10/14/2017 5:00PM EDT	Pending
L2: Plate Girders Design and Stability	Oct 19 2017 1:30PM EDT	<a href="#">Handouts</a>	Available 10/21/2017 5:00PM EDT	Available 10/21/2017 5:00PM EDT	Pending
L3: Effects of Curvature and Skew	Oct 26 2017 1:30PM EDT	<a href="#">Handouts</a>	Available 10/28/2017 5:00PM EDT	Available 10/28/2017 5:00PM EDT	Pending
L4: Fatigue and Fracture	Nov 2 2017 1:30PM EDT	<a href="#">Handouts</a>	Available 11/04/2017 5:00PM EDT	Available 11/04/2017 5:00PM EDT	Pending
Intro To Steel Bridge Design - Final Exam	Nov 23 2017 9:00AM EST			Available 11/20/2017 5:00PM EST	



There's always a solution in steel!

## 8-Session Package Registrants Videos and Quizzes

### Videos

- For Sessions R1 – R4, find access to recordings starting September 11. Recording access expires on November 23.
- For Sessions L1 – L4, find access to recordings within two days after the live air date. Recording access expires three weeks after the live session.

### Quizzes

- For Sessions R1 – R4, find access to quizzes starting September 11. Quizzes are due on November 23.
- For Sessions L1 – L4, find access to quizzes within two days after the live air date. Quizzes are due three weeks after the live session.
- A final exam will also be given.
- Quiz scores are displayed in the Course Resources table.



There's always a solution in steel!

## 8-Session Package Registrants Course Credit

### Attendance and PDH Certificates

- For Sessions R1 – R4, you must pass the quiz to receive credit for the session.
- For Sessions L1 – L4, you have two options to receive credit for the session.
  - Option 1: Watch the session live. Credit for live attendance will be displayed in the Course Resources table within two days of the session.
  - Option 2: Watch the recording and pass the quiz.

### EEU Certificates – Certificate of Completion

- In addition to PDH certificates earned for each individual session, an EEU (Equivalent Education Unit) certificate of completion will be issued for participants who complete the full course. Participants must pass at least 7 of 8 quizzes and the final exam to earn the EEU.

### Distribution of Certificates

- All certificates (PDH and EEU) will be issued after the final session. Only the registrant will receive certificates for the course.



There's always a solution in steel!



There's always a solution in steel.

# Thank You

Please give us your feedback!  
*Survey at conclusion of webinar.*

