

AISC Live Webinars

Thank you for joining our live webinar today.
We will begin shortly. Please standby.

The Science and Art of FEA Modeling
February 9, 2021



AISC Live Webinars

Today's live webinar will begin shortly. Please stand by.

Today's audio will be broadcast through the internet. Please be sure to turn up the volume on your speakers.

Please type any questions or comments in the Q&A window.



AISC Live Webinars

AIA Credit

AISC is a Registered Provider with The American Institute of Architects Continuing Education Systems (AIA/CES). Credit(s) earned on completion of this program will be reported to AIA/CES for AIA members. Certificates of Completion for both AIA members and non-AIA members are available upon request.

This program has been submitted with AIA/CES for continuing professional education. As such, it does not include content that may be deemed or construed to be an approval or endorsement by the AIA of any material of construction or any method or manner of handling, using, distributing, or dealing in any material or product.

Questions related to specific materials, methods, and services will be addressed at the conclusion of this presentation.



AISC Live Webinars

Copyright Materials

This presentation is protected by US and International Copyright laws. Reproduction, distribution, display and use of the presentation without written permission of AISC is prohibited.

© The American Institute of Steel Construction 2021

The information presented herein is based on recognized engineering principles and is for general information only. While it is believed to be accurate, this information should not be applied to any specific application without competent professional examination and verification by a licensed professional engineer. Anyone making use of this information assumes all liability arising from such use.



AISC Live Webinars

Course Description Submitted for AIA CE Credit

The Science and Art of FEA Modeling
February 9, 2021

The translation of a bridge design into a finite element analysis (FEA) model is not a simple data conversion process. The designer needs to determine what behaviors are important to capture and what minimum level of refinement is required to achieve the goals of the analysis. Obtaining a model that accurately reflects the important behavior, without excessive effort or complication, often requires the creative application of basic engineering principles and experience. This webinar will explore some of the frequent modeling issues encountered when creating FEA models of steel bridges and cover some of the more effective solutions.



**Smarter.
Stronger.
Steel.**

AISC Live Webinars

Learning Objectives Submitted for AIA CE Credit

- List several bridge analysis types and explain when each might be used.
- Describe the relationship between accuracy and effort when creating an analysis model.
- Explain how to represent a cross frame as an equivalent beam in a finite element model.
- Identify strategies for verifying the results of a finite element analysis.



**Smarter.
Stronger.
Steel.**

The Science and Art of FEA Modeling

February 9, 2021



Thomas Murphy, SE, PE, PhD
Chairman of the Board,
Senior Vice President, and Chief Technical Officer
Modjeski and Masters, Inc.
Mechanicsburg, PA



**Smarter.
Stronger.
Steel.**

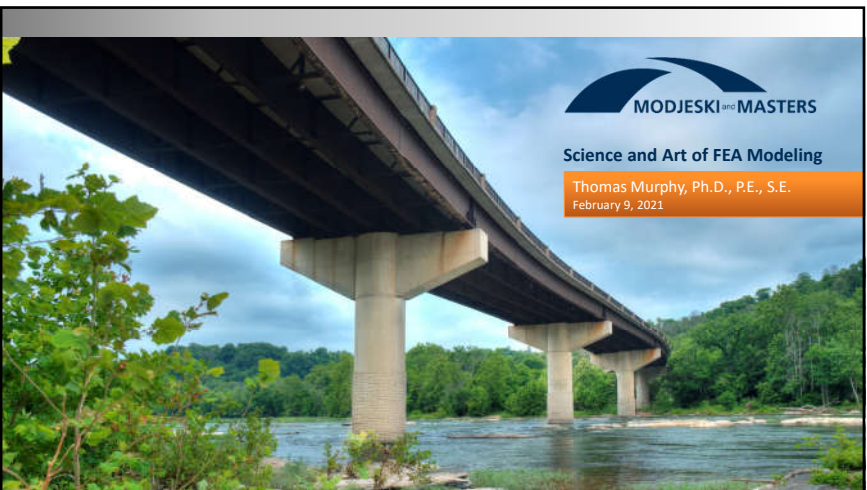

Webinar Outline

- › Level of Modeling Needed
 - › Choices available
 - › Objectives of model
- › Girder
- › Slab
- › Bearings
- › Substructures



9

Initial Considerations

- › What is the goal of the analysis?
- › Determine forces for a strength limit state check?
- › What about service limit states?
- › Will a lateral analysis be needed?
- › Primarily girder moments and shears?
- › Cross-frame forces?
- › Fatigue forces?
- › How will results be verified?



10

Focus of Modeling

- › Steel multi-girder bridges
- › Analysis for the purpose of design
- › Not included:
 - › Distortion induced fatigue modeling
 - › Research-level analyses



11

Before we begin.....

“Structural Engineering is the art of molding materials we do not wholly understand into shapes we cannot precisely analyze to withstand forces we cannot properly assess in such a way that the public at large has no reason to suspect the extent of our ignorance”

- E. H. Brown

12

Strength Limit States

- Conservative modeling assumptions are typically made
 - No participation of the barriers
 - Minimum, or no haunch heights
- Not related to nonlinear behavior
- Design level forces for components

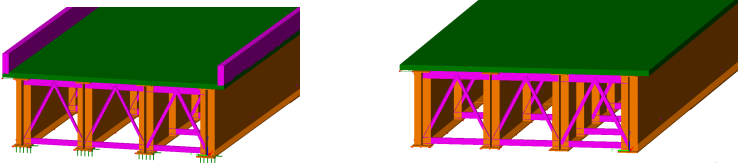

13

Lateral Analysis

- If lateral analysis needed, some model types not practical
 - Grillage
- If dynamic analysis needed
 - Model mass, don't use forces
 - Barriers, wearing surface
 - Substructure/foundation



14

Choosing analysis type

- What type of behavior is expected
 - Distortion of the web of a girder?
 - Torsional moments in girders?
 - Relying on substructure/soil flexibility?
- Any unusual design decisions to model
 - Substringers
 - Integral pier caps



15

Types of Analyses to Consider

- Element types do not define analysis type
- Can use a 3D element in a 1D analysis
- Can use a 1D element in a 3D analysis

- 1D
 - Results a function of one coordinate
 - Line girder
 - Spline girder
- 2D
 - Results a function of two coordinates
 - Grillage
 - Plate with Eccentric Beam (PEB)
- 3D
 - Results a function of three coordinates
 - Shell web, beam flange
 - Shells for girder and slab

16

Grillage, Grid

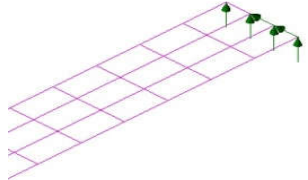

- › Girders are modeled with composite properties
- › Behavior of slab is modeled with transverse beam elements
- › Transverse beams incorporate torsional stiffness
- › Equivalent beams for cross frames
- › Moments, shears in composite girders
- › Not good for lateral analyses

17

Plate with Eccentric Beam, PEB

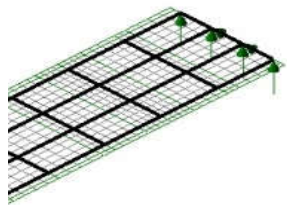

- › Girders are modeled as steel-only, eccentric from slab (or vice versa)
- › Slab is modeled with shell elements (should be SEB)
- › Cross frames modeled with equivalent beams (options)
- › Must combine forces in shell elements with moments and forces in girders to determine moments
- › Good for lateral analyses

18

3D Model

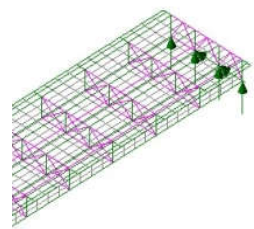

- › Depth of girder modeled with shells
- › Flanges can be beam elements or shells
- › Cross frames can be explicitly modeled
- › Good for transverse analysis
- › Need to integrate shell and beam forces to obtain design moments and shears
- › Not always apparent what quantity to maximize in live load analyses

19

Practical Considerations

- › The more elements, the more output
- › What output is needed
 - › Stresses
 - › Forces
 - › Displacements
- › Accuracy versus effort
- › Lowest level that fulfills objective

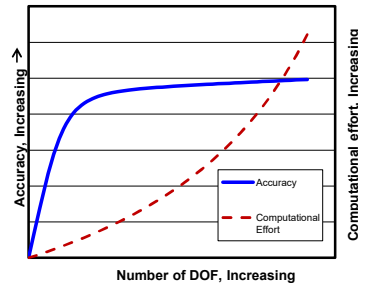

20

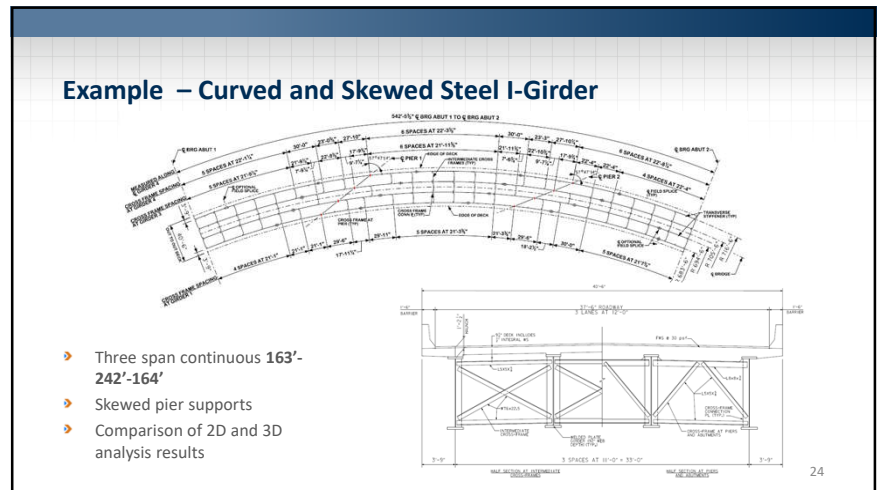
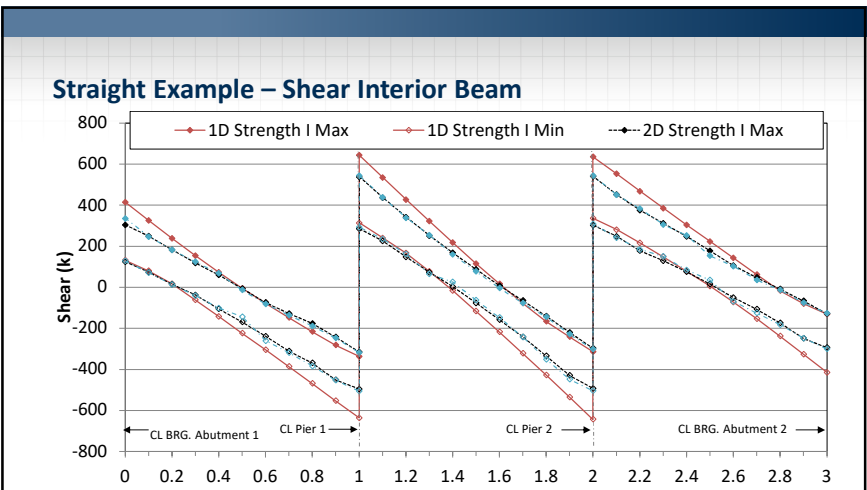
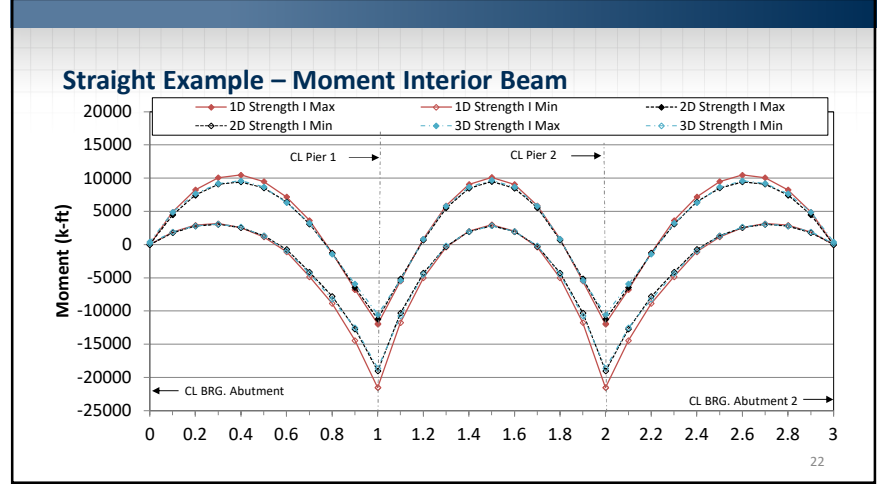
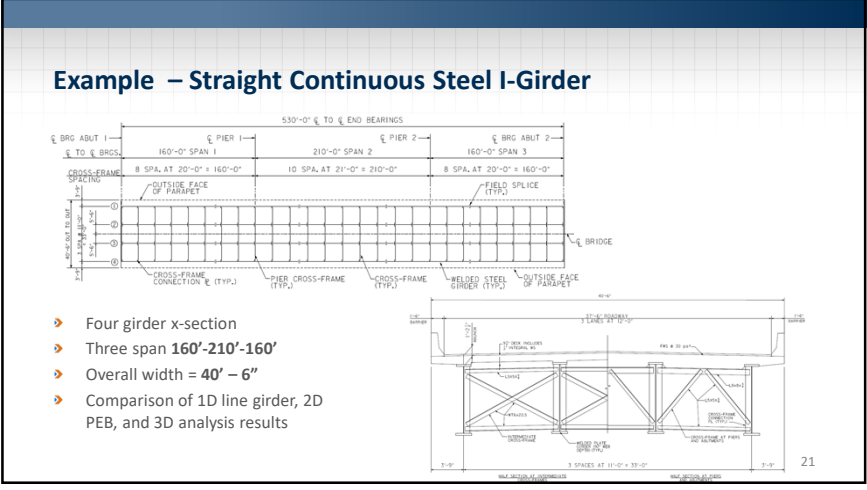

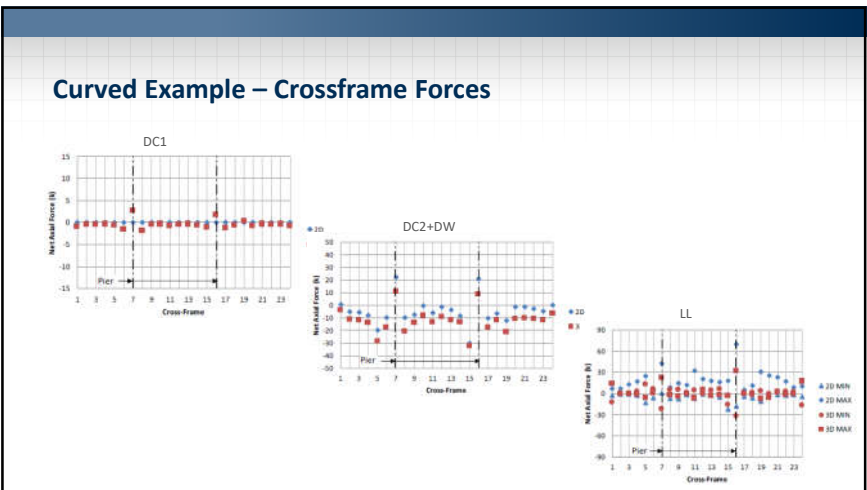
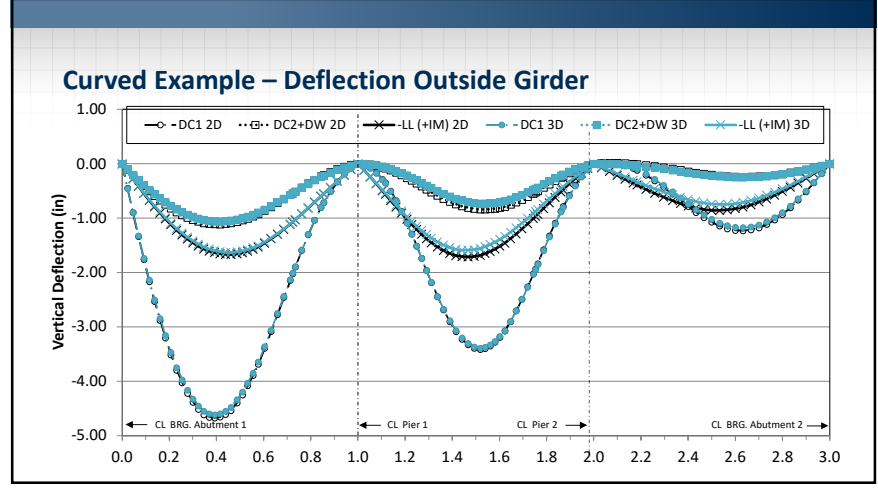
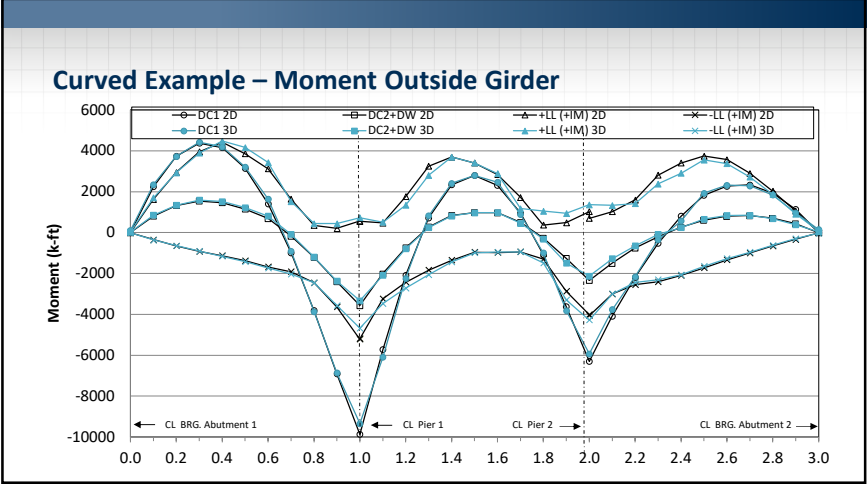

Design Quantities

- Most design procedures need forces, moments, shears as input
- FEA Models provide displacements, strains, stresses
- Significant effort can be required to obtain design quantities
- Analysis model and design model may be different
 - Negative bending over Pier
 - Analysis includes deck in tension, design does not

The diagram illustrates the process of finding the moment from stress values. It shows a cross-section of a beam with a neutral axis. The process involves integrating the stresses and summing them about the neutral axis to determine the moment.

Section Properties and Results

- Not always intuitively obvious how to do this
- When mixing beams of different stiffnesses, tributary slab width will be different.

tributary width for small girder

tributary width for large girder

29

Girder Modeling

- 2D Analyses
 - Section properties
 - Major Axis bending
 - Axial
 - Eccentricities – PEB
 - Torsional properties

30

Torsional Properties

- Warping torsion
- NCHRP Report 725
- Equivalent St. Venant's, J_{EQ}

$$J_{eq} = J \left[1 - \frac{\sinh(pL_b)}{pL_b} + \frac{[\cosh(pL_b) - 1]^2}{pL_b \sinh(pL_b)} \right]^{-1}$$

where $p^2 = GJ/EC_w$

$$C_w = \frac{t_f h^2}{12} \left\{ \frac{b_1^3 b_2^3}{(b_1^4 + b_2^4)} \right\}$$

where: b_1, b_2 = individual flange widths (in.)
 h = distance between flange centroids (in.)
 t_f = flange thickness (in.)

$$J_{eq} = J + \frac{6EIh^2}{GL_b^3}$$

31

Girder Modeling

- 3D Analyses
 - Shell Flanges
 - Beam Flanges
 - Flange transitions
 - Stiffeners
 - Not modeled
 - Beam elements
 - Shell elements
 - Cross-frame connections

Flange thickness transition

32



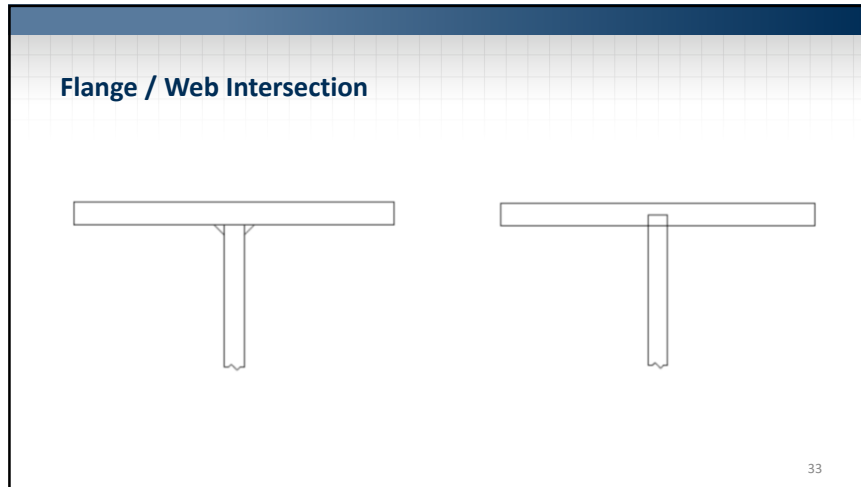

Web Modeling

- › Flexural behavior
- › Shear behavior
- › Parabolic shear stress profile
- › Compatible with flange mesh
- › Compatible with connection/stiffener locations
- › Minimum 4 elements for the depth of the web
- › Keep aspect ratios below 5:1

34

Cross Frames

- › Transverse connections between girders
- › For straight, square bridges enforce compatibility between girders
- › Load dependent on stiffness
- › Provide bracing to girders during erection (stability)
- › For curved girder bridges, can be main load path
- › Loading less dependent on stiffness
- › 2D models, need equivalent beam properties (could model explicitly)

35

Cross Frame Modeling – 2D

- › Representing a truss with a beam element
- › Trusses typically have significant shear deformations
- › Substituting a beam element with only bending stiffness introduces significant errors
- › Need to use a beam element with shear stiffness
- › Adjust moment of inertia and shear area to best match behavior of trussed cross frame
- › Don't forget axial properties – acts composite with deck

36

Cross Frame Modeling - Flexure

- Step 1 – Determine equivalent moment of inertia
- Model cross frame
- Apply equal and opposite forces to chords
- Determine deflections Δ_1 and Δ_2

$$I_{eq} = \frac{ML}{E\theta}$$

Equal and opposite forces

Fixed supports

Δ_1

Δ_2

37

Cross Frame Modeling - Shear

- Step 2 – Determine equivalent shear area
- Apply vertical load to one end
- Determine deflections Δ

$$A_{eq} = \frac{VL}{G \left(\Delta - \frac{VL^2}{3EI_{eq}} \right)}$$

Unit Load

Δ

38

Cross Frame Modeling – 3D

- Connections to Girders
 - Easiest to frame into flange/web intersections
 - Normally only small errors are introduced
 - For short cross-frames, model actual geometry
 - Need to model connection stiffener (beam elements, or shells)
- Connection eccentricity
 - Reduces stiffness
 - Most important when forces driven by compatibility
 - Can model directly or use reduction factor

39

Deck Slab

- Acts compositely with girders for bending loads
- Distributes loads transversely to girders
- Design methods often don't use analysis results (empirical method)
- Research indicates ultimate strength governed by punching shear failure mode
- Shell elements typically used
- Solid elements very rarely

40

Meshing

- For beam elements, generally don't need a refined mesh
- Different story for shells and solids
- Stiffness decreases as mesh is refined
- Need to determine if mesh is too coarse for purpose of analysis
- Post-processing requirements also important – integrating stresses to forces and moments
- Mesh refinement study – refine mesh, compare results

41

Boundary Conditions / Bearings

- A frequent source of modeling errors
- Sufficient boundary conditions needed to ensure stability
- Commonly idealized as completely free or fully fixed to either translation or rotation (infinitely rigid)

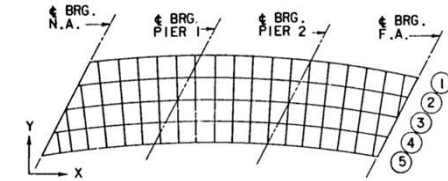

42

Bearings

- Never friction free or perfectly rigid
- Restrained directions often have small movement before engaging restraints
- Very large forces can develop in model that don't occur in real bearing
- Directions of restraint and release often a source of trouble (modeled bearing orientation)
- Eccentricity of bearing from neutral axis – rotation/movement coupling

43

Rotation/Movement Coupling

- When girders rotate at support, bearings move longitudinally
- Different rotations among girders means different longitudinal movements
- Can result in large, self-equilibrating longitudinal forces in bearings at a support

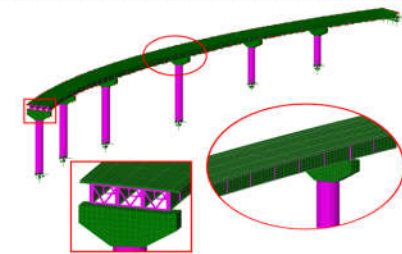

44

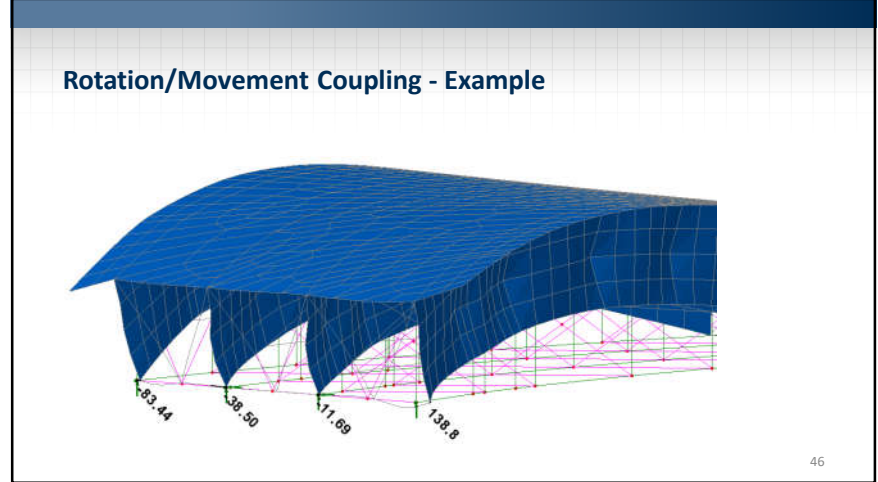
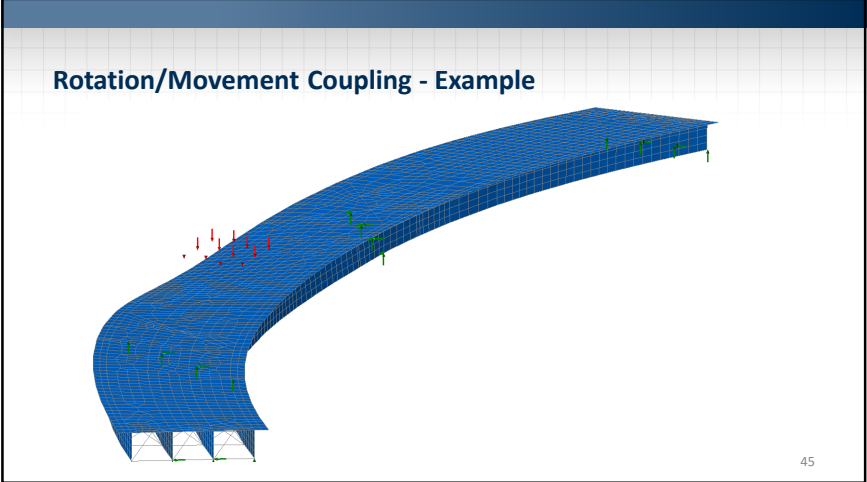

Friction in Bearings

- Friction in sliding bearings dependent on many factors
- Never zero
- For high vertical loads, can be significant force
- Effects of forces on other components needs to be accounted for

47

Substructure / Foundation Modeling

- Stiffness / flexibility can have large effects on superstructure forces / moments
- Rotation / movement coupling of bearings
- Integral abutments
- Multiple fixed piers

48



Substructure Modeling

- › Single or multi-column piers – beam elements
- › Wall piers – beam or shell, depending on aspect ratio



Substructure Modeling

- › What stiffness to use?
 - › Elastic uncracked gross
 - › Cracked
 - › Effective
- › Uncracked most conservative for forces
- › If deflections are important, then cracked - stability
- › More accurate – effective stiffness
- › Many options for increasing accuracy – benefits vs cost need evaluation





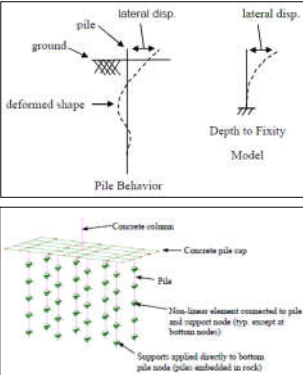

Soil Structure Interaction

- › Different methods of including SSI
- › Equivalent depth to fixity
 - › Common errors
 - › Inflection point meaning
- › Separate foundation modeling vs. integrated
- › Linear springs, nonlinear springs, solid modeling

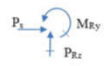
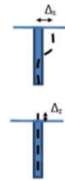
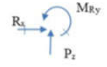

Foundation Stiffness

- › If using separate analysis for foundation, need to incorporate in bridge model
- › Build up stiffness matrix based on applied loads
- › Linearized nonlinear behavior

Loads and Boundary Conditions	Deformed Shape	Stiffness Terms
		$K_{11} = P_x/\Delta_x$ $K_{31} = M_{Ry}/\Delta_x$
		$K_{33} = P_z/\Delta_z$
		$K_{25} = M_y/\theta_y$ $K_{15} = P_{Rx}/\theta_y$

Verification of Analysis Results

- As part of QA/QC procedures, need to check results of analysis
- Can be challenging for more complex analyses
- Several different options
- "Sanity check"
- Sensitivity study
- Input check
 - Data
 - Assumptions
- Output check
 - Compare to hand calculations
 - Compare to published results for similar structure
 - Separate analysis with different methods – simpler/approximate
 - Separate analysis with different methods – similar complexity

53

Verification of Analyses

- Method used dependent on several factors
 - Complexity of the behavior being modeled
 - Similarity to other structures
 - Unusual features of the design
 - Complexity of the model
- Checks need to encompass full span of analysis
- Ultimately the design quantities are what matters
- Deflection check does not ensure bending moments are correct



Published Data

- AISC Moment, Shears, and Reactions for Continuous Highway Bridges
- Roark's Formulas for Stress and Strain
- AISC Steel Construction Manual
- NSBA LRFD Simon

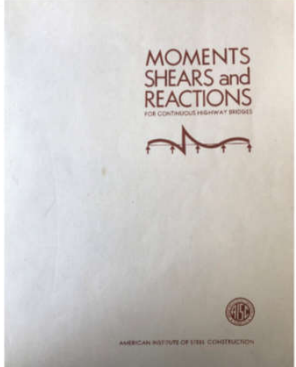
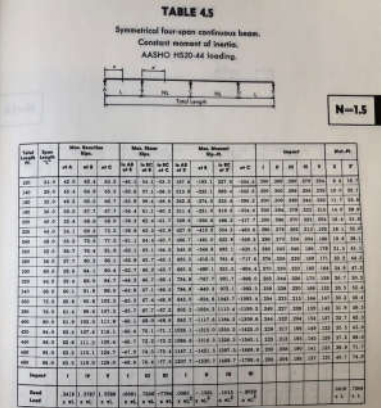

Published Moment Tables

56



General Checks of a Model

- Do the total reactions equal the load applied?
- Are the reactions in the directions expected?
- Are the reactions distributed as expected?
- Is the displaced shape continuous?
- Are the magnitudes of the displacements reasonable?
- Is everything that should be connected together moving together?



Verification of Complex Models

- Start with a simplified model, check the results with published or hand calculated data
- Add complexity, check results
- Example: reduce model to a simply supported beam, check moments, deflections, reactions

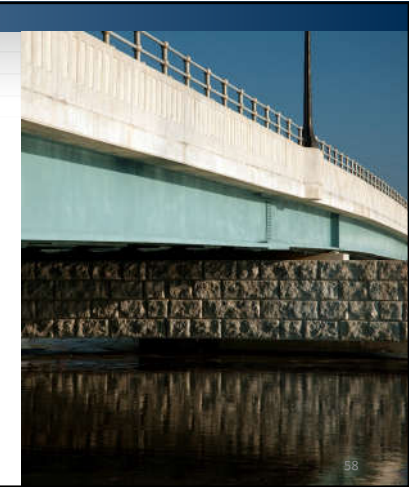

Approximate Methods

- A large variety of methods have been developed in the past to save effort
- Elastic center method for frames
- Column analogy for frames
- Three-moments equation
- Portal frame method
- V-Load method for curved bridges
- FHWA Curved Girder Manual
- Methods can be used to aid in modeling
- Elastic center method decouples stiffness terms (diagonalizes stiffness matrix)
- Can use simple support springs in place of full matrix

59

FHWA Curved Girder Manual

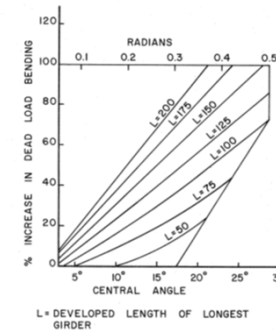

FIGURE 43
PERCENT INCREASE IN DEAD LOAD BENDING MOMENT IN LONGEST CURVED GIRDER

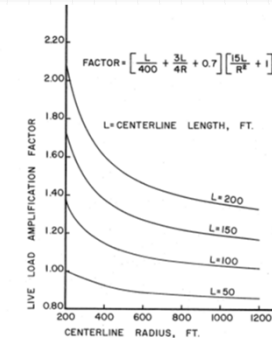

FIGURE 44
AMPLIFICATION FACTOR FOR LIVE LOAD BENDING MOMENT IN THE LONGEST CURVED GIRDER

60

Stability Analysis

- Global, local stability
 - P- Δ vs. P- δ
 - Building industry practice vs. Bridge
 - How to incorporate in analysis
- Verifying stability analyses
- Newmark numerical buckling method
- Spring-link simple models

Column

Moments

Small Displacement (1st Order) Contribution

P δ Contribution

P Δ Contribution

61

Stability Analysis

- Stability analysis and design
 - Adding geometric nonlinear option sufficient?
 - Initial imperfections and residual stresses
 - Elastic buckling load approach
- Elastic buckling load approach
 - Use analysis to find critical elastic buckling load
 - Back-calculate a value for kl/r based on the critical elastic load
 - Use this kl/r in design equations which account for residual stresses and initial imperfections

62

For More Information

- G13.1-2019 Guidelines for Steel Girder Bridge Analysis
- FHWA Manual for Refined Analysis in Bridge Design and Evaluation
- NCHRP Report 725

63

Acknowledgements

- Dr. John Kulicki, Andrew Adams, Dr. Phil Ritchie, Dr. Nohemy Galindez, Vanessa Storlie, Jared Weisman, Travis Hopper
- Brandon Chavel, Dr. Don White
- Mike Grubb, Dominic Colletti
- Dr. Brian Kozy, Reggie Holt
- Staff at Modjeski and Masters

64

QUESTIONS

PDH Certificates

- You will receive an email on how to report attendance from: registration@aisc.org.
- Be on the lookout: Check your spam filter! Check your junk folder!
- Completely fill out online form. Don't forget to check the boxes next to each attendee's name!



PDH Certificates

- Reporting site (URL will be provided in the forthcoming email).
- Username: Same as AISC website username.
- Password: Same as AISC website password.



AISC | Thank you

