



AISC
Night School

Thank you for joining our live webinar today.
We will begin shortly. Please standby.

Thank you.

Need Help?
Call ReadyTalk Support: 800.843.9166



Today's audio will be broadcast through the internet.

Alternatively, to hear the audio through the phone, dial 888 224 7958.



There's always a solution in steel!

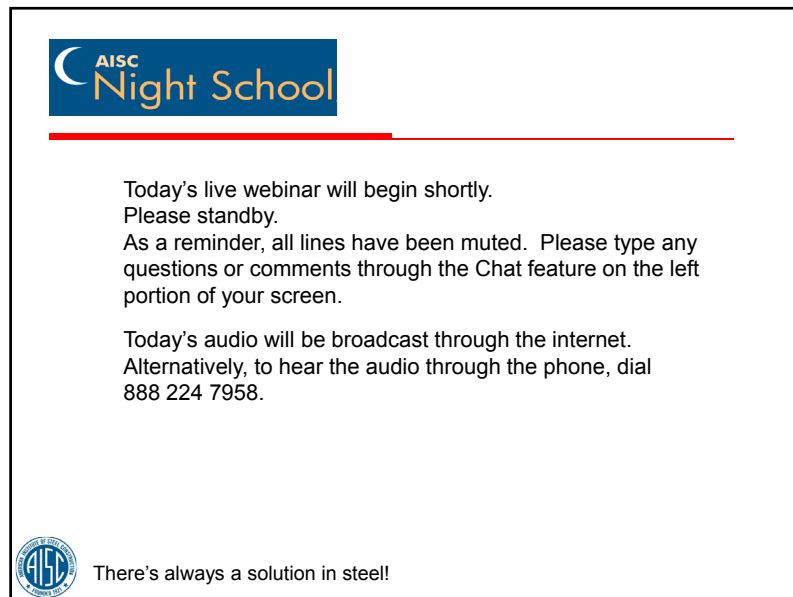

Today's live webinar will begin shortly.
Please standby.

As a reminder, all lines have been muted. Please type any questions or comments through the Chat feature on the left portion of your screen.

Today's audio will be broadcast through the internet.
Alternatively, to hear the audio through the phone, dial 888 224 7958.



There's always a solution in steel!



AISC is a Registered Provider with The American Institute of Architects Continuing Education Systems (AIA/CES). Credit(s) earned on completion of this program will be reported to AIA/CES for AIA members. Certificates of Completion for both AIA members and non-AIA members are available upon request.

This program is registered with AIA/CES for continuing professional education. As such, it does not include content that may be deemed or construed to be an approval or endorsement by the AIA of any material of construction or any method or manner of handling, using, distributing, or dealing in any material or product.

Questions related to specific materials, methods, and services will be addressed at the conclusion of this presentation.



There's always a solution in steel!





Copyright Materials

This presentation is protected by US and International Copyright laws. Reproduction, distribution, display and use of the presentation without written permission of AISC is prohibited.

© The American Institute of Steel Construction 2017

The information presented herein is based on recognized engineering principles and is for general information only. While it is believed to be accurate, this information should not be applied to any specific application without competent professional examination and verification by a licensed professional engineer. Anyone making use of this information assumes all liability arising from such use.



There's always a solution in steel!



Course Description

Session 1: Design Criteria
January 30, 2017

In Lesson 1, loads as required by IBC 2015 and ASCE 7-10 are discussed as well as owner established design criteria. Advantages and disadvantages of various roof and wall systems are presented. Serviceability issues and other design considerations are discussed in detail for roof and wall types. Expansion joint requirements and details for expansion joints for both buildings without overhead cranes and those with overhead cranes are presented. Member selection guidelines for optimum design are discussed.



There's always a solution in steel!



Learning Objectives

- Establish design criteria and loads for building design based on IBC 2015, ASCE 7-10 and owner requirements.
- List advantages and disadvantages of various roof and wall systems.
- Describe expansion joint requirements and explain appropriate expansion joint details based on the type of building being designed.
- Describe the guidelines for the optimum member design.



There's always a solution in steel!



Design of Industrial Buildings
Lesson 1: Design Criteria
January 30, 2017



Presented by
James M. Fisher, PE, PhD
Emeritus Vice President, Computerized
Structural Design

There's always a solution in steel.



AISC Night School 13

Design of Industrial Buildings Lesson 1



Presenter:
Jim Fisher



There's always a solution in steel!

9

AISC Night School



There's always a solution in steel!

10

AISC Night School



There's always a solution in steel!

11

Night School- 13

- In this Night School a complete design of an industrial building with a 50 ton overhead crane will be presented along with a discussion of the critical design issues. Prior to that discussion we will discuss design issues that pertain to buildings, both with and without, overhead cranes.
- Calculations will be presented in a manner that serve as a teaching tool for engineers.



There's always a solution in steel!

12



Night School- 13

There are eight 1.5 hours of discussion.

Lessons include:

- Lesson 1: Loads, Roofs, Walls, Serviceability, and Expansion Joints
- Lesson 2: Roof Trusses, Framing Considerations, Bay Analysis, Hanging Loads, RTUs, Roof Diaphragms, and Details
- Lesson 3: Lateral Load Systems and Examples
- Lesson 4: Project Description (50 ton crane building): Design Criteria and Preliminary Design
- Lesson 5: Crane Runway Design, Building Loads and Analysis
- Lesson 6: Column Design, Connections, Specification of Components and Anchor Rod Design
- Lesson 7: Longitudinal and Endwall Bracing
- Lesson 8: Roof, Wall and Stability Bracing



There's always a solution in steel!

13

Buildings w/o Overhead Cranes

• Lesson 1

- Loading Conditions and Load Combinations
- Owner Established Criteria
- Roof Systems
- Wall Systems
- Serviceability Considerations
- Expansion Joints



There's always a solution in steel!

14

Codes, Loads and Other Design Criteria



Also ASCE 7-10 and the AISC Seismic Provisions



There's always a solution in steel!

15

Loads and Combinations

• Loads from *IBC* and *ASCE 7*

- Dead Loads
- Live Loads
- Snow Loads
- Wind Loads
- Seismic Loads
- Other Loads

• Load Combinations



There's always a solution in steel!

16



Required Design Loads

Code specified loads are specified in locally adopted governing codes, i.e., the International Building Code, in most jurisdictions.



There's always a solution in steel!

17

Dead Load – Roofs & Floors

- Steel Systems
 - Roof deck, joists and Joist Girders
 - Floor deck, concrete slabs, wide flange beams, joists, Joist Girders
 - Columns



There's always a solution in steel!

18

Dead Load - Roof

- Roofing – Ballast and Membrane 10 - 18 psf
- Insulation 2 - 4 psf
- Deck 2 - 4 psf
- Framing – Joists, and infill beams 3 - 5 psf
- Framing – Girders 1 - 2 psf
- Ceiling 1 - 4 psf
- M - E - P 3 - 10 psf



There's always a solution in steel!

19

Dead Loads - Walls

- Exterior walls
 - Glass and aluminum curtain walls 8 - 16 psf
 - Brick and block 70 - 100 psf
 - Brick and steel studs 45 - 55 psf
 - Brick and wood studs 45 - 55 psf
 - Exterior insulation systems 10 - 15 psf
- Interior walls
 - Studs and drywall or plaster 5 - 20 psf
 - Concrete block 30 - 60 psf



There's always a solution in steel!

20



Live Loads – IBC 1607

- 1607.3 Uniform live loads
- “The live loads used in the design of buildings and other structures shall be the maximum loads expected in the intended use or occupancy but in no case shall be less than the minimum uniformly distributed unit loads required by Table 1607.1.”



There's always a solution in steel!

21

Live Loads – IBC 1607

- 1607.4 Concentrated loads
- “Floors and other similar surfaces shall be designed for uniformly distributed live loads prescribed in Section 1607.3 or the concentrated live loads, given in Table 1607.1, whichever produces the greater load effects.”
- Distribute over area 2.5- feet by 2.5- feet. Locate to produce maximum effects.



There's always a solution in steel!

22

Live Loads – IBC 1607

- 1607.9 Impact loads
- “The live loads specified in Sections 1607.3 through 1607.8 include allowance for impact conditions. Provisions shall be made in the structural design for uses and loads that involve unusual vibration and impact forces.”



There's always a solution in steel!

23

Live Loads – IBC 1607

- 1607.9.2 Machinery
- Weight of machinery and moving loads to be increased by
 - 20% - light, shaft- or motor driven
 - 50% - reciprocation or power driven
- Percentages shall be increased where specified by the manufacturer.



There's always a solution in steel!

24



Snow Loads – IBC 1608

- Ground Snow Load, p_g
- Flat Roof Snow Load, p_f
 - Exposure Factor
 - Thermal Factor
 - Importance Factor
- Sloped Roof Snow Load, p_s
 - Surface
 - Temperature



There's always a solution in steel!

25

Snow Loads – IBC 1608

- Drifts on Lower Roofs, Behind Parapets and at Projections
 - Roof length (source of snow)
 - Height of roof offset, etc.
- Sliding snow
 - Extent of upper roof
 - Surface of upper roof
 - Slope
 - Snow Guards



There's always a solution in steel!

26

Snow Loads – IBC 1608

- Rain-on-Snow
 - Where $p_g \leq 20$ psf, add 5 psf surcharge to balanced case only.



There's always a solution in steel!

27

Rain Loads – IBC 1611

- 1611.1 Design Rain Loads
- “Each portion of a roof shall be designed to sustain the load of rainwater that will accumulate on it if the primary drainage system for that portion is blocked, plus the uniform load caused by water that rises above the inlet of the secondary drainage at its design flow.”



There's always a solution in steel!

28



Rain Loads – IBC 1611

- $R = 5.2 (d_s + d_h)$ (Eq. 16-36)
 - Where
 - d_s = height to secondary inlet
 - d_h = hydraulic head above secondary inlet



There's always a solution in steel!

29

Rain Loads- Ponding

- AISC Specification and Appendix 2
- AISC Design Guide 3, "Serviceability Design Considerations for Steel Buildings" (Second Edition)
- SJI Technical Digest 3, "Structural Design of Steel Joist Roofs to Resist Ponding Loads"



There's always a solution in steel!

30

Rain Loads



There's always a solution in steel!

31

Rain Loads



There's always a solution in steel!

32



Rain Loads



There's always a solution in steel!

33

Rain Loads



There's always a solution in steel!

34

Rain Loads

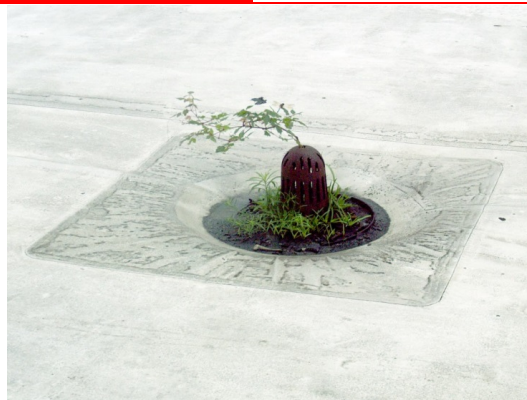

There's always a solution in steel!

35

Wind Loads – IBC 1609

- Basic Wind Speed
- Topography
- Importance Factor
- Exposure Category
- Enclosure Classification
- Gust
- Building Geometry



There's always a solution in steel!

36

Wind Loads – IBC 1609

- Main Wind-Force Resisting Systems
- Components and Cladding
 - Effective Area
- Reference ASCE 7 – 10, “Minimum Design Loads for Buildings and Other Structures”
- Another reference is the ATC Windspeed web site: windspeed.atcouncil.org



There's always a solution in steel!

37

Wind Loads – ASCE 7-10

Main Wind-Force Resisting System (MWFRS)

- Method 1- Directional Procedure
- Method 2- Envelope Procedure
- Method 3- Directional Procedure for Building Appurtenances (roof top equipment, free standing walls etc.)
- Method 4- Wind Tunnel Procedure



There's always a solution in steel!

38

Earthquake Loads- ASCE 7-10

- Seismic Design Category A
 - $F_x = 0.01w_x$
 - where
 - F_x = the design lateral force applied at story x
 - w_x = the proportion of the total dead load of the structure, D , located or assigned to level x
- R values are not used



There's always a solution in steel!

39

Earthquake Loads- ASCE 7-10

- Seismic Design Categories B and C
- $R = 3$ permitted and should be used
- ANSI/AISC 360-10 *Specification for Structural Steel Buildings* is applicable (Seismic Provisions not required)



There's always a solution in steel!

40



Earthquake Loads- ASCE 7-10

- Design Categories D, E, and F
- Use R values per ASCE 7-10 Table 12.2-1
- ANSI/AISC 341-10 *Seismic Provisions for Structural Steel Buildings*, is required



There's always a solution in steel!

41

Seismic Design Criteria- ASCE 7 Chapter 12

- Structural System Selection – basic lateral and vertical seismic force-resisting system per Table 12.2-1 or Combinations per Sections 12.2.2, .3 or .4
 - Seismic design category (SDC)
 - Height limitations



There's always a solution in steel!

42

Seismic Loads

- The 2015 IBC references ASCE 7-10 for seismic design requirements. Spectral accelerations (S_s and S_1) are provided in maps contained in this standard. However, these values can also be obtained from the US Geological Survey (USGS) website:
- <http://earthquake.usgs.gov/hazards/designmaps/>.



There's always a solution in steel!

43

Load Combinations- IBC 1605

- 1605.2 Load combinations using strength design or load and resistance factor design
- 1605.3 Load combinations using allowable stress design
 - 1605.3.1 Basic load combinations
 - 1605.3.2 Alternate basic load combinations



There's always a solution in steel!

44



Load Combinations - LRFD

- **BASIC COMBINATIONS – IBC 1605.2**

$1.4D$

$1.2D + 1.6L + 0.5(L_r \text{ or } S \text{ or } R)$

$1.2D + 1.6(L_r \text{ or } S \text{ or } R) + (f_1L \text{ or } 0.5W)$

$1.2D + 0.6W + 0.5(L_r \text{ or } S \text{ or } R)$

$1.2D + 1.0E + f_1L + f_2S$

$0.9D + 1.0W$

$0.9D + 1.0E$

Relative to one story industrial buildings: $f_1 = 0.5$ for live loads, $f_2 = 0.7$ for roofs that do not shed snow and 0.2 for other roof configurations



There's always a solution in steel!

45

Load Combinations - ASD

- **BASIC COMBINATIONS – IBC 1605.3**

D

$D + L$

$D + (L_r \text{ or } S \text{ or } R)$

$D + (0.6W \text{ or } 0.7 E)$

$D + 0.75L + 0.75(0.6W \text{ or } 0.7 E) + 0.75(L_r \text{ or } S \text{ or } R)$

$0.6D + 0.6W$

$0.6D + 0.7E$

Note: Flood and Lateral Pressure Loads not shown



There's always a solution in steel!

46

AISC Specification

- B2 Loads and Load Combinations
- “The **loads and load combinations** shall be as stipulated by the *applicable building code*. In the absence of a building code, the loads and load combinations shall be those stipulated in SEI / ASCE 7. For design purposes, the *nominal loads* shall be taken as the *loads* stipulated by the applicable building code.”



There's always a solution in steel!

47

Other Design Criteria

- Drift Criteria
- Loss Prevention (FM Global or other insurance requirements)
- Roof Drainage
- OSHA rules



There's always a solution in steel!

48



Drift Criteria

- Code Requirements
 - See ASCE 7- 10, Section 12.12 and Table 12.12-1 for allowable story drift for seismic loads.



There's always a solution in steel!

49

Loss Prevention (FM Global)

- Wind Forces on Buildings
- Roof Deck Securement
- Metal Roof Systems
- Perimeter Roof Flashing
- Roof Loads for New Construction

For additional information
Go to :<http://www.fmglobal.com>



There's always a solution in steel!

50

Drainage

- Drainage and Slopes
 - Built-up and membrane roofs
 - Metal roofs

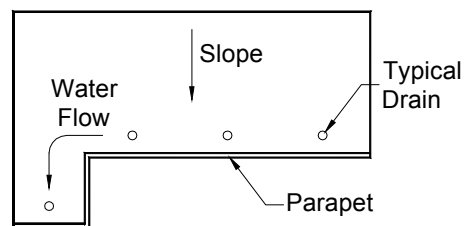

There's always a solution in steel!

51

OSHA Rules

- Code of Federal Code Regulations 29, Part 1926, Subpart R regulates the work of steel erection.
- These rules apply to steel erectors and their employees.
- These rules prescriptively describe features of the structure that should be incorporated in the construction documents and shop drawings.



There's always a solution in steel!

52



Owner Established Criteria

- Slab-on-Grade Design
- Jib Cranes
- Type of Usage
- Future Expansion



There's always a solution in steel!

53

Slabs on Grade



There's always a solution in steel!

54

Jib Cranes

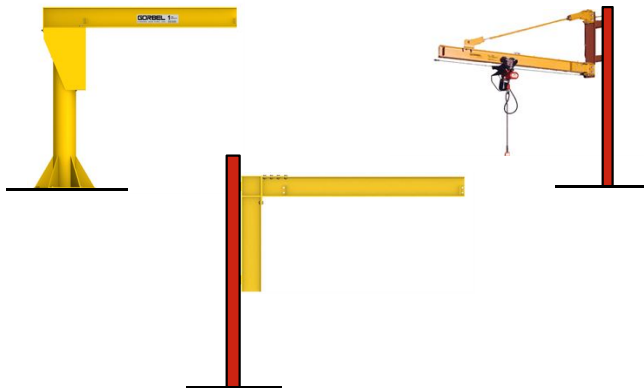

There's always a solution in steel!

55

Type of Usage:

Forklift trucks require special attention:

- Type of Walls
- Column Protection
- Use of Guard Rails



There's always a solution in steel!

56



Future Expansion

- Direction of primary and secondary framing
- Roof Slopes
- Location of X bracing



There's always a solution in steel!

57

Exterior Gutters

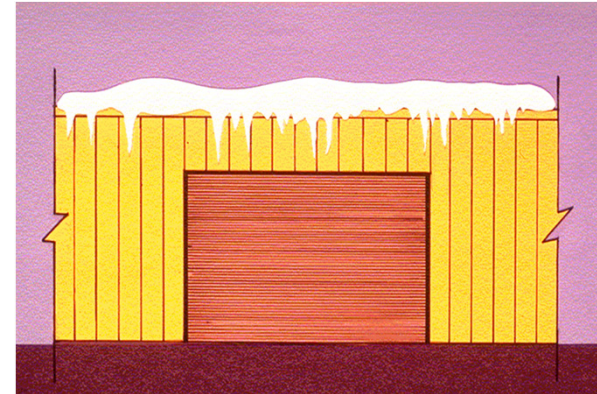

There's always a solution in steel!

58

Roof Systems

Expensive Portion of Building:
Therefore:

- Do not over design
- Note mechanical loads on drawings



There's always a solution in steel!

59

Member Selection Guidelines

- Deck
- Open Web Steel Joists and Beams
- Columns



There's always a solution in steel!

60



Structural Roof Systems

- Through Fastened Roofs (TFR)
 - 100 to 200 feet between joints, if supported by cold formed Zees or Cees
- Standing Seam Roofs
 - 150 to 200 feet between joints



There's always a solution in steel!

61

Deck Selection Guidelines

- SDI Recommended Spans
- FM Global and other Insurance Requirements



There's always a solution in steel!

62

SDI Maximum Deck Spans

Fire Rating	Deck Depth	Deck Gage						
		22	21	20	19	18	17	16
3.5" LWC Above Flutes	2	8'-5"	9'-0"	9'-6"	10'-6"	11'-4"	12-1"	12-8"
	3	9'-1"	10'-9"	11'-7"	12-10"	13-8"	14-7"	15-3"
	4.5" NWC Above Flutes							
2-Hr. Fire Rating	2	6'-2"	7'-6"	8'-1"	8'-11"	9'-8"	10'-3"	10'-9"
	3	6'-6"	7'-9"	8'-10"	10'-10"	11'-7"	12'-4"	13'-0"
	2.75" LWC Above Flutes							
1-Hr. Fire Rating	2	8'-10"	9'-6"	10'-1"	11'-2"	12'-0"	12-10"	13-5"
	3	10'-1"	11'-7"	12-3"	13-6"	14-5"	15-4"	16-1"
	3.5" NWC Above Flutes							
1-Hr. Fire Rating	2	7'-2"	8'-2"	8'-8"	9'-7"	10'-4"	11'-0"	11-7"
	3	7'-5"	8'-10"	10'-1"	11'-7"	12-5"	13-3"	13-11"



There's always a solution in steel!

63

FM Global Data for Roof Deck

Vulcraft Division - Nucor Corp 2100 Rexford Rd Charlotte NC 28211

Trade Name:	Type 1.5A
Type:	Type A Narrow Rib
Thickness:	18, 20 or 22 ga. (0.0474, 0.0358, 0.0295 in. [1.2, 0.91, 0.75 mm])
Depth:	1.5 in. (38 mm)
Max Spans:	4 ft 10 in. (1.5 m) for 22 ga. (0.0295 in. [0.75 mm]) 5 ft 3 in. (1.6 m) for 20 ga. (0.0358 in. [0.91 mm]) 6 ft 0 in. (1.8 m) for 18 ga. (0.0474 in. [1.20 mm])
Trade Name:	Type 1.5F
Type:	Type F Intermediate Rib
Thickness:	18, 20 or 22 ga. (0.0474, 0.0358, 0.0295 in. [1.2, 0.91, 0.75 mm])
Depth:	1.5 in. (38 mm)
Max Spans:	4 ft 11 in. (1.5 m) for 22 ga. (0.0295 in. [0.75 mm]) 5 ft 5 in. (1.7 m) for 20 ga. (0.0358 in. [0.91 mm]) 6 ft 3 in. (2.0 m) for 18 ga. (0.0474 in. [1.20 mm])
Trade Name:	Type 1.5B, 1.5BI
Type:	Type B Wide Rib
Thickness:	18, 20 or 22 ga. (0.0474, 0.0358, 0.0295 in. [1.2, 0.91, 0.75 mm])
Depth:	1.5 in. (38 mm)
Max Spans:	6 ft 0 in. (1.8 m) for 22 ga. (0.0295 in. [0.75 mm]) 6 ft 6 in. (2.0 m) for 20 ga. (0.0358 in. [0.91 mm]) 7 ft 5 in. (2.3 m) for 18 ga. (0.0474 in. [1.20 mm])



There's always a solution in steel!

64

Secondary Roof Members

- Cold formed members
- Open Web Steel Joists
- HSS



There's always a solution in steel!

65

C and Z Purlins

Designed as Continuous Members

- Z's can be nested
- Z's can be loaded through shear center, C's cannot
- Z's may have principal axis vertical



There's always a solution in steel!

66

Open Web Steel Joists

- Load tables for uniformly loaded simple span members
- For other end conditions and other loading conditions see the SJI Catalog



There's always a solution in steel!

67

HSS

- Used primarily for columns and lintels

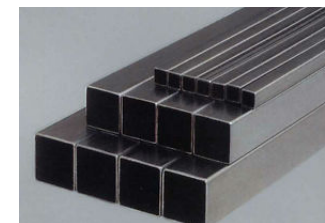

There's always a solution in steel!

68



Wall Systems

- Field Assembled Metal Panels
- Factory Assembled Metal Panels
- Precast Concrete Panels
- Masonry Walls



There's always a solution in steel!

69

Wall Systems- Considerations

Cost Interior Surface Characteristics
Appearance Acoustical Considerations
Insulating Properties Fire Consideration
Dust Control Ease of Erection
Maintenance Considerations
Ease of Future Expansion
Speed of Erection



There's always a solution in steel!

70

Field Assembled Panels

- Rapid Erection
- Good Cost Competition
- Easily Replaced
- Openings Easily Created
- Panels Are Lightweight
- Easy Acoustic Treatment



There's always a solution in steel!

71

Factory Assembled Panels

- Light Weight
- Hard Interior Liner
- “Clean” Appearance



There's always a solution in steel!

72



Factory Assembled Panels

- Color matching for expansion may be a problem
- Inside - Outside temperature gradient may cause bowing between girts
- Openings may be difficult
- Attention to details and tolerances is important



There's always a solution in steel!

73

Precast Wall Panels

Hollow Core Slabs
Double - T Sections
Site Cast Tilt - Up Panels
Factory Cast Panels



There's always a solution in steel!

74

Precast Wall Panels

- Hard Surface
- Excellent Fire Resistance
- Less Maintenance
- Girts Not Required
- Excellent Sound Barrier



There's always a solution in steel!

75

Precast Wall Panels

- Color matching may be difficult
- Possible condensation problems
- Adding wall openings difficult
- Require heavier foundations
- Require heavier eave struts
- Heavy cranes required for erection
- Future expansion may be difficult



There's always a solution in steel!

76



Masonry Walls

- Many colors, textures and finishes available
- Economical
- Special reinforcement is easy
- Can be utilized as shear walls
- Easy maintenance



There's always a solution in steel!

77

Masonry Walls

- Low bending resistance
- May require heavy foundation
- Special considerations required for masonry ties



There's always a solution in steel!

78

Masonry Wall Cracks

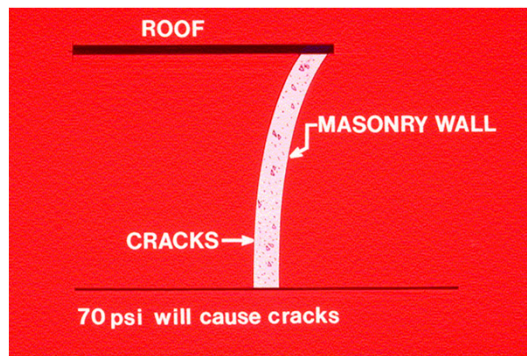

There's always a solution in steel!

79

Checks for Masonry Walls

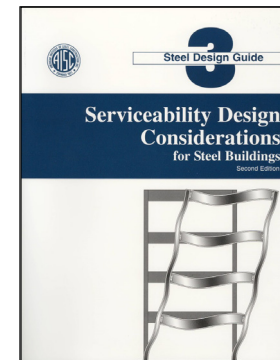

There's always a solution in steel!

80



Girts

Required for metal panels and some precast and masonry panels.

C and Z, hot or cold rolled sections most commonly used.



There's always a solution in steel!

81

Wind Columns

- Bay spacing greater than 30 feet
- End Walls
- Suction and Uplift may be important
- Roof must take top reaction



There's always a solution in steel!

82

Wind Columns

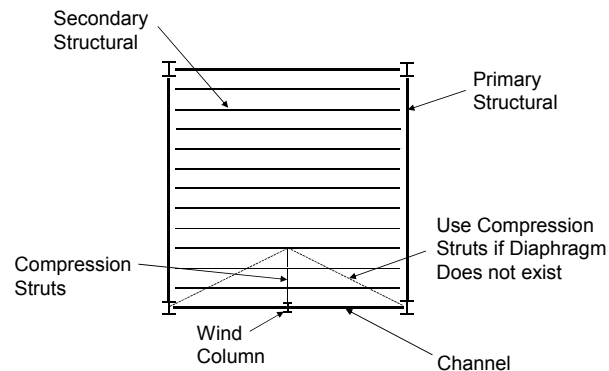

There's always a solution in steel!

83

Wind Columns

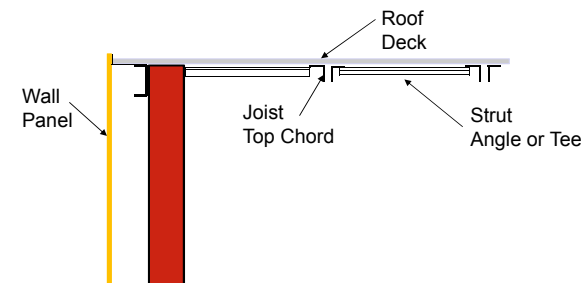

There's always a solution in steel!

84



Serviceability Limit States

- Expansion and Contraction
- Deflection



There's always a solution in steel!

85

Strength vs. Serviceability

- Strength limit states control the safety of the structure and must be met.
- Serviceability limit states define the functional performance of the structure and should be met.
- Consider different loading requirements.



There's always a solution in steel!

86

AISC Design Guides

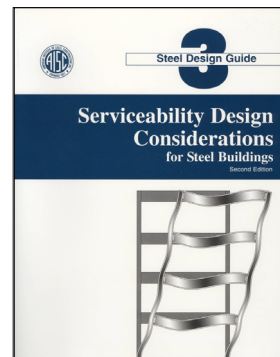
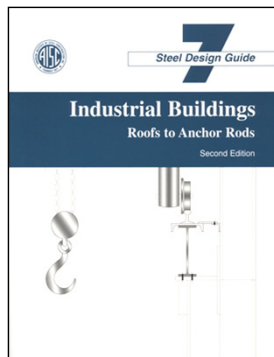

There's always a solution in steel!

87

Serviceability Requirements

- Live Load Deflection Limit for Roof Members
 - Joists and Joist Girders: $\text{Span}/240$
 - SSR: $\text{Span}/180$
- Deflection Limit for Walls
 - Wind Columns: $\text{Span}/120$ - 10 year wind
 - Girts: $\text{Span}/120$ - 10 year wind
 - Panels: $\text{Span}/120$ - 10 year wind



There's always a solution in steel!

88



Serviceability- SSR

Structural Element	Deformation	Recommended	Loading
Expansion Joints	Horizontal Movement	150 ft. to 200 ft. Maximum	Thermal
Roof	Slope	1 / 4 in. per ft. Minimum	Drainage
Purlin	Vertical Deflection	L / 150 Maximum	Snow Load
Purlin	Vertical Deflection	Positive Drainage	DL+ 0.5 x Snow DL+ 5 psf (min)



There's always a solution in steel!

89

Expansion Joints

VARIABLES

Mean temperature during construction



Expected service temperature range



There's always a solution in steel!

90

Expansion Joints

This lesson will focus on the basic requirements used to determine if an expansion joint is required at a given location, or locations, within a structure.

Area dividers as provided in roof membranes to control the effects of thermal loads for roofing are not discussed, as they are relief joints in the membrane and do not require a joint in the roof structure below.

Control joints for materials other than structural steel are also eliminated from this discussion.



There's always a solution in steel!

91

Expansion Joints

- AISC 360, Section L.7, "The effects of thermal expansion and contraction of a building shall be considered."
- ASCE 7-10, Appendix C: "Dimensional changes in a structure and its elements due to variations in temperature, relative humidity, or other effects shall not impair the serviceability of the structure."



There's always a solution in steel!

92



General Requirements

From the National Roofing Contractors Association, structural expansion joints shall be used:

- Where steel framing, structural steel, or decking change direction.
- Where separate wings of L, U, T or similar configurations exist.
- Where the type of decking changes, for example, where a precast concrete deck and a steel deck abut.
- Where additions are connected to existing buildings.
- At junctions where interior heating conditions change, such as a heated office abutting unheated warehouse, canopies, etc.
- Where movement between vertical walls and the roof deck may occur.



There's always a solution in steel!

93

Length Between Expansion Joints vs. Design Temperature Change

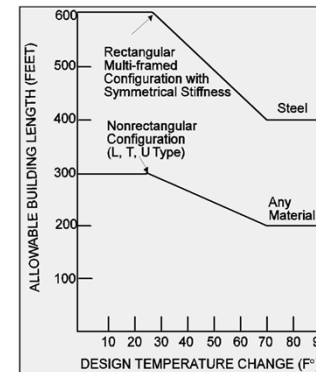

Federal Construction Council, 1974



There's always a solution in steel!

94

Use of the Curves

The curves are directly applicable to buildings of beam and column construction, hinged at the base, and with heated interiors. When other conditions prevail, the following rules are applicable:

1. If the building will be heated only and will have hinged-column bases, use the allowable length as specified;
2. If the building will be air conditioned as well as heated, increase the allowable length by 15 percent (provided the environmental control system will run continuously);
3. If the building will be unheated, decrease the allowable length by 33 percent;
4. If the building will have fixed column bases, decrease the allowable length by 15 percent;
5. If the building will have substantially greater stiffness against lateral displacement at one end of the plan dimension, decrease the allowable length by 25 percent.



There's always a solution in steel!

95

Analytical Calculation-Moment Frame

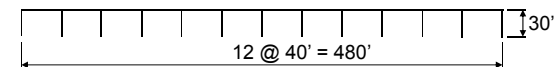

All columns: W12X90 All beams: W24X52
 $\Delta_T = 50^\circ \text{ F}$
 Fixed base $M = 74.4 \text{ kip-ft.}$, $\Delta = 0.87 \text{ in.}$ $f = 6.2 \text{ ksi}$
 Pinned base $M = 36.5 \text{ kip-ft.}$, $\Delta = 0.92 \text{ in.}$ $f = 3.1 \text{ ksi}$



There's always a solution in steel!

96

Federal Construction Council

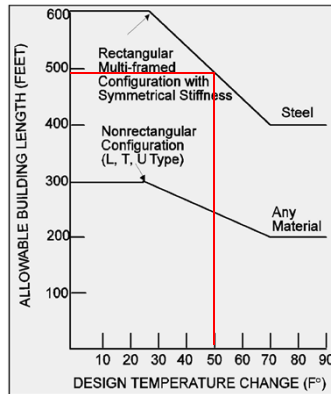

There's always a solution in steel!

97

Beam Expansion Joint

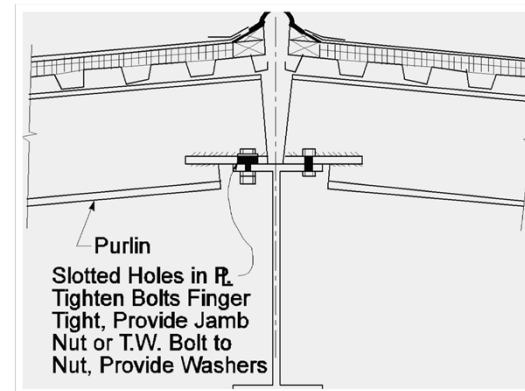

There's always a solution in steel!

98

Beam Expansion Joint

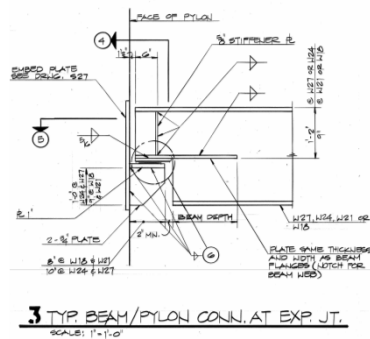

There's always a solution in steel!

99

Beam Expansion Joint

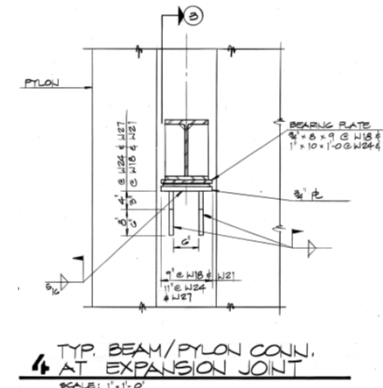

There's always a solution in steel!

100

Beam Expansion Joint

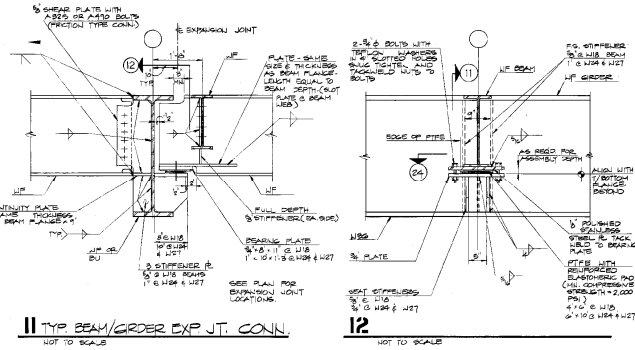

11 TYP. BEAM/GIRDER EXP. JT. CONN.
NOT TO SCALE

12
NOT TO SCALE



There's always a solution in steel!

101

Beam Expansion Joint

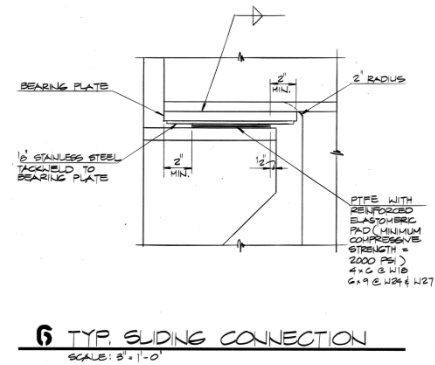

6 TYP. SLIDING CONNECTION
SCALE: 5'-1'-0"



There's always a solution in steel!

102

Deck Expansion Joint

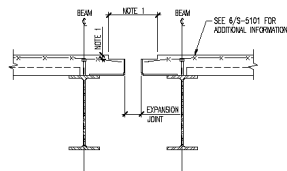

NOTES:
1. COORDINATE DEPRESSIONS AT SLAB EDGES WITH EXPANSION JOINT COVER REQUIREMENTS.



There's always a solution in steel!

103

Special Details

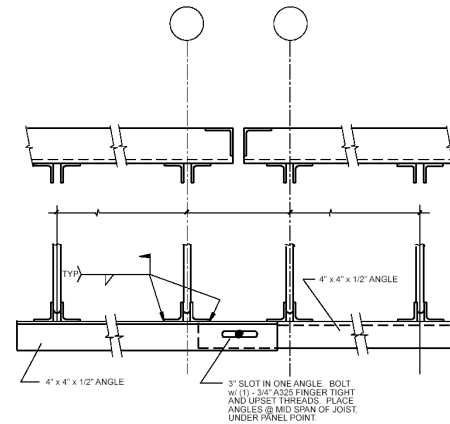

104



Expansion Joint Shear Transfer

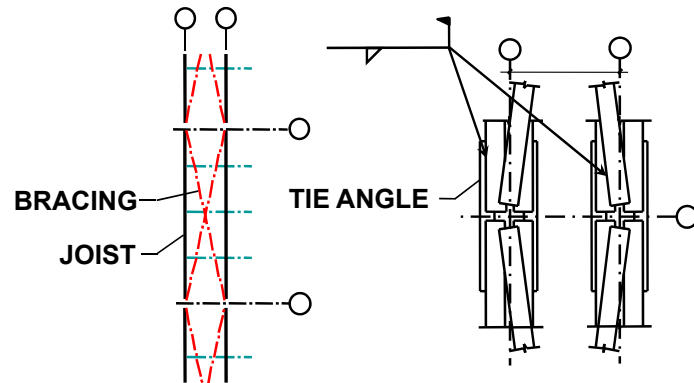

There's always a solution in steel!

1.1#

Overhead Crane Buildings- Crane Runway Beams

Only as a last resort should expansion joints be provided for runway beams:

- By providing oversize holes at the beam ends expansion and contraction can be allowed in each beam segment, so that an expansion joint is not necessary.
- If an expansion joint is provided in the runway system, careful consideration must be given as to how the lateral crane forces are transferred across the joint.
- Special details are required to prevent high shears in the crane rail, and large forces in the rail clamps.



There's always a solution in steel!

106

Overhead Crane Buildings- Crane Rails

Expansion joints should never be provided in the crane rails:

- Such joints often lead to rail cracking. In lieu of such joints, the rail should be allowed to expand toward the stops.
- Adequate space must be allowed between the end of the rail and the face of the crane stops.
- In addition, a rail clamping system which allows longitudinal expansion and contraction of the rail must be provided, particularly in runway systems which exceed 400 ft. in length.



There's always a solution in steel!

107

Large Clear Span Structures

- Long span structures and components often require special expansion joint hardware.



There's always a solution in steel!

108



End of Lesson 1



There's always a solution in steel!

109

Individual Webinar Registrants

PDH Certificates

Within 2 business days...

- You will receive an email on how to report attendance from: registration@aisc.org.
- Be on the lookout: Check your spam filter! Check your junk folder!
- Completely fill out online form. Don't forget to check the boxes next to each attendee's name!



There's always a solution in steel!

Individual Webinar Registrants

PDH Certificates

Within 2 business days...

- New reporting site (URL will be provided in the forthcoming email).
- Username: Same as AISC website username.
- Password: Same as AISC website password.



There's always a solution in steel!

8-Session Registrants

PDH Certificates

One certificate will be issued at the conclusion of all 8 sessions.



There's always a solution in steel!



8-Session Registrants

QUIZZES

Access to the quiz: Information for accessing the quiz will be emailed to you by Thursday. It will contain a link to access the quiz. EMAIL COMES FROM NIGHTSCHOOL@AISC.ORG

Quiz and Attendance records: Posted Tuesday mornings. www.aisc.org/nightschool - click on Current Course Details.

Reasons for quiz:

EEU – must take all quizzes and final to receive EEU

PDHS – If you watch a recorded session you must take quiz for PDHS.

REINFORCEMENT – Reinforce what you learned tonight. Get more out of the course.

NOTE: If you attend the live presentation, you do not have to take the quizzes to receive PDHS.



There's always a solution in steel!

8-Session Registrants

RECORDINGS

Access to the recording: Information for accessing the recording will be emailed to you by this Thursday. The recording will be available for two weeks. For 8-session registrants only. EMAIL COMES FROM NIGHTSCHOOL@AISC.ORG.

PDHS – If you watch a recorded session you must take AND PASS the quiz for PDHS.



There's always a solution in steel!

Thank You

Please give us your feedback!
Survey at conclusion of webinar.

There's always a solution in steel.

