



Thank you for joining our live webinar today.
We will begin shortly. Please standby.

Thank you.

Need Help?
Call ReadyTalk Support: 800.843.9166



Today's audio will be broadcast through the internet.

Alternatively, to hear the audio through the phone, dial 888 224 7958.



There's always a solution in steel!



Today's live webinar will begin shortly.
Please standby.
As a reminder, all lines have been muted. Please type any questions or comments through the Chat feature on the left portion of your screen.

Today's audio will be broadcast through the internet.
Alternatively, to hear the audio through the phone, dial
888 224 7958.



There's always a solution in steel!



AISC is a Registered Provider with The American Institute of Architects Continuing Education Systems (AIA/CES). Credit(s) earned on completion of this program will be reported to AIA/CES for AIA members. Certificates of Completion for both AIA members and non-AIA members are available upon request.

This program is registered with AIA/CES for continuing professional education. As such, it does not include content that may be deemed or construed to be an approval or endorsement by the AIA of any material of construction or any method or manner of handling, using, distributing, or dealing in any material or product.

Questions related to specific materials, methods, and services will be addressed at the conclusion of this presentation.





Copyright Materials

This presentation is protected by US and International Copyright laws. Reproduction, distribution, display and use of the presentation without written permission of AISC is prohibited.

© The American Institute of Steel Construction 2017

The information presented herein is based on recognized engineering principles and is for general information only. While it is believed to be accurate, this information should not be applied to any specific application without competent professional examination and verification by a licensed professional engineer. Anyone making use of this information assumes all liability arising from such use.



Course Description

Session 4: Preliminary Design Procedures
February 27, 2017

Lesson 4 sets the stage for a complete building design for a two bay 50-ton overhead crane building. The project description and design criteria including all loads and serviceability requirements are discussed. Preliminary design procedures and calculations are provided for the runway girders, columns, and roof members beginning with the determination of required eave height based upon the owner's requirement for the crane hook height. A discussion on the various choices for column types and the preliminary design hints for each is provided. A weight comparison between 30 ft. and 40 bay spacing is also provided.





Learning Objectives

- Establish design criteria and loads for building design based on IBC 2015, ASCE 7-10 and owner requirements.
- List the steps for the preliminary design procedures of runway girders, columns and roof members.
- Calculate the eave height based upon the owner's requirement for the crane hook height.
- Discuss the design differences in using 30 foot bays versus 40' bays.



Design of Industrial Buildings

Session 4: Preliminary Design Procedures
February 27, 2017



Presented by
James M. Fisher, PE, PhD
Emeritus Vice President, Computerized
Structural Design

There's always a solution in steel.



AISC Night School 13

Design of Industrial Buildings Lesson 4



CSD Presenter:
Jim Fisher



There's always a solution in steel!

Buildings with Overhead Cranes

- **Lesson 4**
 - Project Description and Design Criteria
 - Serviceability Requirements
 - Determination of Top of Rail and Eave Elevation
 - Preliminary Design Calculations



There's always a solution in steel!

10

Design of an Industrial Crane Building

• **Lesson 4**

- **Project Description and Design Criteria**
- Serviceability Requirements
- Determination of Top of Rail and Eave Elevation
- Preliminary Design Calculations



There's always a solution in steel!

11

Project Description

- Project Name: ABC Building
- Project Number: 160455
- Date: January 4, 2017
- Project Engineers: Fisher/Van de Pas
- Type of Building: Overhead Crane



There's always a solution in steel!

12

Project Description

- Building width: 120 ft
- Building length : 240 ft (Approximately)
- Eave height: TBD
- Provisions for future expansion: None
- Bay spacing: 6@30 ft, 1@60 ft
- One Interior column per bay
- Endwall column spacing: 6@20 ft



There's always a solution in steel!

13

Building Foot Print

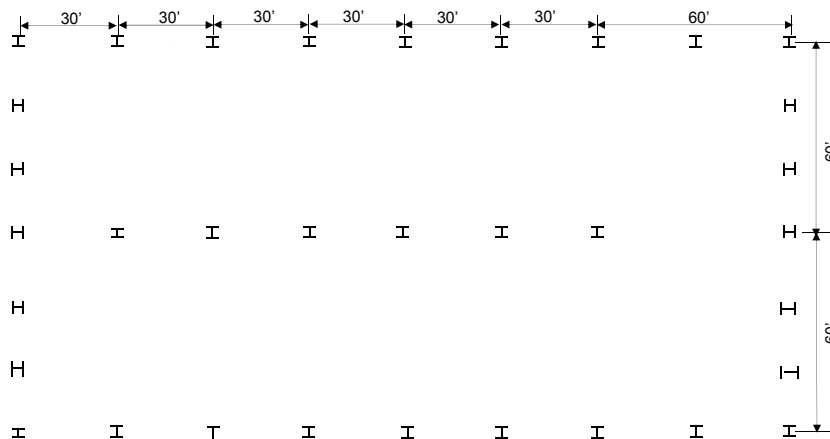

There's always a solution in steel!

Cross Section

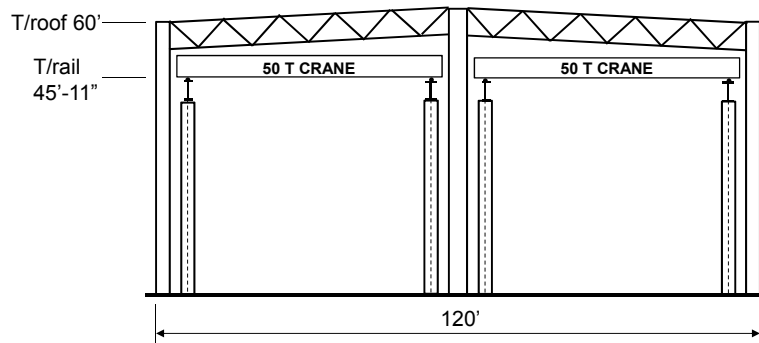

There's always a solution in steel!

15

Project Description

- 50 ton, Top Running Crane, Class D
- Quantity: 1 per aisle
- Hook height: 45 ft
- Roof type: Standing Seam on Joists
- Wall type: R- panel with Continuous Z's
- Automatic Sprinkler System



There's always a solution in steel!

16

Codes and Standards

- Building Code: IBC 2015
- Minimum Design Loads For Buildings And Other Structures (ASCE 7-10)
- Building Department Contact: John Smith
 - Date: July 6, 2016
 - Local Ordinances: None

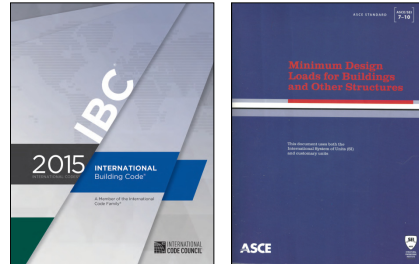

There's always a solution in steel!

17

Local Code Requirements

- Ground Snow Load: 15 psf
- Frost Depth: 24 in.
- Seismic Spectral Acceleration:
 - $S_s = 1.054g$
 - $S_1 = .400g$

<http://earthquake.usgs.gov/designmaps/us/application.php>



There's always a solution in steel!

18

Design Specifications

- Specification For Structural Steel Buildings, ANSI/AISC 360-10
- Seismic Provisions for Structural Steel Buildings, Including Supplement 1, ANSI/AISC 341-10
- Building Code Requirements For Reinforced Concrete, ACI 318-14
- Structural Welding Code, ANSI/AWS D1.1-10



There's always a solution in steel!

19

Design Specifications

- Steel Joist Institute, 43rd Edition, Standard Specifications, 2011
- North American Specification for the Design of Cold-Formed Steel Structural Members, ANSI S100-2007
- FM Global Requirements

<http://www.fmglobal.com>



There's always a solution in steel!

20

Loads

- ROOF DEAD LOAD
 - Roofing (SSR) 2.0 psf
 - Insulation 1.0 psf
 - Roof Bracing 1.0 psf
 - Joists 3.0 psf
 - Joist Girders 3.0 psf
 - Columns 6.0 psf
 - MEP Allowance 3.0 psf
 - **Total 19.0 psf**
- WALL DEAD LOAD **3.0 psf**
(Includes Girts)



There's always a solution in steel!

21

Loads

- ROOF LIVE LOADS
 - 20.0 psf (reduceable)
- SNOW LOADS
 - Ground Snow Load (p_g): 15.0 psf
 - Importance Factor, $I_s = 1.0$ ASCE Table 1.5-2
 - Thermal Factor, $C_t = 1.0$ ASCE Table 7-3
 - Exposure Factor, $C_e = 1.0$ (partially exposed) ASCE Table 7-2
 - Building Category: II
- Flat Roof Snow Load: $p_f = 0.7C_e C_t I_s p_g = 10.5$ psf ASCE (7.3-1)
- Minimum Roof Snow for Low Slope Roof: $p_f = I_s p_g = 15$ psf ASCE (7.3.4)
- Add Rain-on-Snow Surcharge: $p_f = 15$ psf + 5 psf = 20 psf ASCE (7.10)



There's always a solution in steel!

22

Loads

WIND LOADS

- Occ. II Risk category, Table 1.5-1
- $V = 115$ Basic wind speed (3 second gust), mph, Fig. 26.5-1A
- Exp = C Exposure category, Section 26.7
- $K_d = 0.85$ Wind directionality factor, Section 26.6 & Table 26.6-1
- $K_{zt} = 1$ Topographic factor, Section 26.8 & Fig. 26.8-1
- Encl. = Enclosure classification, Section 26.10
- $R = 1$ Large volume buildings reduction factor, Section 26.11.1.1
- $G = 0.85$ Gust factor, Section 26.9



There's always a solution in steel!

23

Loads

• SEISMIC LOADS

- Spectral Acceleration, S_s : 1.054g
- Spectral Acceleration, S_1 : 0.400g
- Occupancy Category: II
- Site Class: D
 - Soil shear wave velocity, \bar{v}_s : 800 ft/sec
 - Standard penetration resistance, \bar{N} : 15 blows
 - Soil undrained shear strength, $\bar{\tau}_u$: 1500 psf
- Importance Factor, I : 1.0
- Seismic Design Category: TBD



There's always a solution in steel!

24

Loads- Crane

- The following crane loads are required for the preliminary design of the frames:
 - Crane column loads:
 - Maximum and minimum
 - Lateral thrusts:



There's always a solution in steel!

25

Loads- Crane

- A good reference to determine preliminary crane loads is the Whiting Handbook.
- The following data is provided in the Whiting Handbook for a 50 ton cab operated crane with a 60 ft bridge .
 - Wheel loads: $WL = 78.0$ kips (Without impact, Two wheel end truck)
 - Wheel spacing: $s = 11$ ft
 - Crane weight: $CW = 90.8$ kips
 - Trolley weight: $TW = 31.2$ kips



There's always a solution in steel!

26

Loads- Crane

- Crane Vertical Column Loads:
 - $P_{\max} = 78 + (19/30)(78) = 127.4$ kips
 - $WL_{\min} = CW / 4 = 90.8 / 4 = 22.6$ kips (per wheel)
 - $P_{\min} = 22.6 + (19/30)(22.6) = 36.9$ kips
- Lateral Load to Frames:
 - $H = 20\%(\text{Lifted load} + \text{Trolley weight})$
 - $H = (0.20)(100,000 + 31,200)/1000 = 26.2$ kips
 - Load per wheel = $26.2/4 = 6.6$ kips
 - Column load, $H_L = 6.6 + (19/30)(6.6) = 10.8$ kips



There's always a solution in steel!

27

Loads- Crane

- Crane loads for longitudinal bracing design
 - Longitudinal Force: $LF = 10\%(WL)$
 - $LF = 0.10(78) = 7.8$ kips/wheel
 - Total LF per runway beam = $(2)(7.8) = 15.6$ kips
- Bumper Force (From AISC DG 7)
 - 2 times LF = $(2)(15.6) = 31.2$ kips
 - 10% times CW
= $(0.10)(90.8) = 9.1$ kips

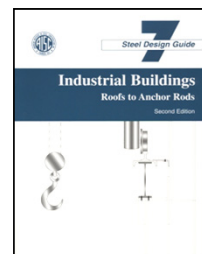

There's always a solution in steel!

28

Design of an Industrial Crane Building

• Lesson 4

- Project Description and Design Criteria
- **Serviceability Requirements**
- Determination of Top of Rail and Eave Elevation
- Preliminary Design Calculations



There's always a solution in steel!

29

Serviceability Requirements

- Live Load Deflection Limit for Roof Members
 - Joists and Joist Girders: $\text{Span}/240$
 - SSR: $\text{Span}/180$
- Deflection Limit for Walls
 - Wind Columns: $\text{Span}/120$ - 10 year wind
 - Girts: $\text{Span}/120$ - 10 year wind
 - Panels: $\text{Span}/120$ - 10 year wind



There's always a solution in steel!

30

Serviceability- SSR

Structural Element	Deformation	Recommended	Loading
Expansion Joints	Horizontal Movement	150 ft. to 200 ft. Maximum	Thermal
Roof	Slope	1 / 4 in. per ft. Minimum	Drainage
Purlin	Vertical Deflection	L / 150 Maximum	Snow Load
Purlin	Vertical Deflection	Positive Drainage	DL+ 0.5 x Snow DL+ 5 psf (min)



There's always a solution in steel!

31

Serviceability

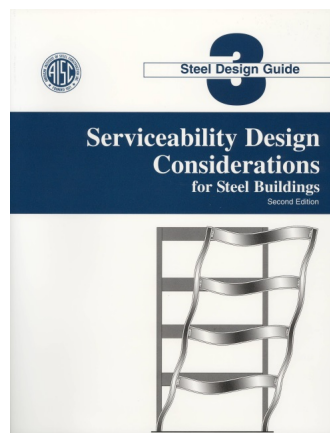

There's always a solution in steel!

32

Serviceability Requirements

- Deflection Limit for Crane Runways:
 - Vertical: $\text{Span}/800$
 - Horizontal: $\text{Span}/400$
- Frame Drift Limits:
 - $H/100$ @ Eave- 10 year wind or crane lateral
 - $H/240$, or 2 in. max. @ TOR- 10 year wind or crane lateral



There's always a solution in steel!

33

Design of an Industrial Crane Building

- **Lesson 4**
 - Project Description and Design Criteria
 - Serviceability Requirements
 - **Determination of Top of Rail and Eave Elevation**
 - Preliminary Design Calculations



There's always a solution in steel!

34

TOR and Eave Elevations

- A minimum hook height for the 50 ton cab operated crane was specified to be not less than 45 ft.
- The top of crane rail (TOR) and the building eave height are established from the hook height.
- Since the crane has not been ordered the crane dimensions are approximated.
- A good source for dimensional information is the Whiting Crane Handbook. The following information was taken from the handbook:



There's always a solution in steel!

Whiting Data

62 WHITING CRANE HANDBOOK

Fig. 36

Crane Load	Span	A	B	C	D	E	G	H	I	J	K	L
40 TON 10.7 ALK For each # of rails in span # of rails at each end # of rails at each end	120'	10'	10'	10'	10'	10'	10'	10'	10'	10'	10'	10'
	150'	10'	10'	10'	10'	10'	10'	10'	10'	10'	10'	10'
	180'	10'	10'	10'	10'	10'	10'	10'	10'	10'	10'	10'
	210'	10'	10'	10'	10'	10'	10'	10'	10'	10'	10'	10'
	240'	10'	10'	10'	10'	10'	10'	10'	10'	10'	10'	10'
	270'	10'	10'	10'	10'	10'	10'	10'	10'	10'	10'	10'
	300'	10'	10'	10'	10'	10'	10'	10'	10'	10'	10'	10'
	330'	10'	10'	10'	10'	10'	10'	10'	10'	10'	10'	10'
	360'	10'	10'	10'	10'	10'	10'	10'	10'	10'	10'	10'
	390'	10'	10'	10'	10'	10'	10'	10'	10'	10'	10'	10'
	420'	10'	10'	10'	10'	10'	10'	10'	10'	10'	10'	10'
	450'	10'	10'	10'	10'	10'	10'	10'	10'	10'	10'	10'
50 TON 13.7 ALK For each # of rails in span # of rails at each end # of rails at each end	120'	10'	10'	10'	10'	10'	10'	10'	10'	10'	10'	10'
	150'	10'	10'	10'	10'	10'	10'	10'	10'	10'	10'	10'
	180'	10'	10'	10'	10'	10'	10'	10'	10'	10'	10'	10'
	210'	10'	10'	10'	10'	10'	10'	10'	10'	10'	10'	10'
	240'	10'	10'	10'	10'	10'	10'	10'	10'	10'	10'	10'
	270'	10'	10'	10'	10'	10'	10'	10'	10'	10'	10'	10'
	300'	10'	10'	10'	10'	10'	10'	10'	10'	10'	10'	10'
	330'	10'	10'	10'	10'	10'	10'	10'	10'	10'	10'	10'
	360'	10'	10'	10'	10'	10'	10'	10'	10'	10'	10'	10'
	390'	10'	10'	10'	10'	10'	10'	10'	10'	10'	10'	10'
	420'	10'	10'	10'	10'	10'	10'	10'	10'	10'	10'	10'
	450'	10'	10'	10'	10'	10'	10'	10'	10'	10'	10'	10'

WHITING CRANE HANDBOOK 63

Fig. 38

Crane Load	Span	A	B	X	Y	Clearance	Clearance	Clearance
40 TON 10.7 ALK	120'	10'	10'	10'	10'	10'	10'	10'
	150'	10'	10'	10'	10'	10'	10'	10'
	180'	10'	10'	10'	10'	10'	10'	10'
	210'	10'	10'	10'	10'	10'	10'	10'
	240'	10'	10'	10'	10'	10'	10'	10'
	270'	10'	10'	10'	10'	10'	10'	10'
	300'	10'	10'	10'	10'	10'	10'	10'
	330'	10'	10'	10'	10'	10'	10'	10'
	360'	10'	10'	10'	10'	10'	10'	10'
	390'	10'	10'	10'	10'	10'	10'	10'
	420'	10'	10'	10'	10'	10'	10'	10'
	450'	10'	10'	10'	10'	10'	10'	10'
50 TON 13.7 ALK	120'	10'	10'	10'	10'	10'	10'	10'
	150'	10'	10'	10'	10'	10'	10'	10'
	180'	10'	10'	10'	10'	10'	10'	10'
	210'	10'	10'	10'	10'	10'	10'	10'
	240'	10'	10'	10'	10'	10'	10'	10'
	270'	10'	10'	10'	10'	10'	10'	10'
	300'	10'	10'	10'	10'	10'	10'	10'
	330'	10'	10'	10'	10'	10'	10'	10'
	360'	10'	10'	10'	10'	10'	10'	10'
	390'	10'	10'	10'	10'	10'	10'	10'
	420'	10'	10'	10'	10'	10'	10'	10'
	450'	10'	10'	10'	10'	10'	10'	10'



There's always a solution in steel!



Whiting Data

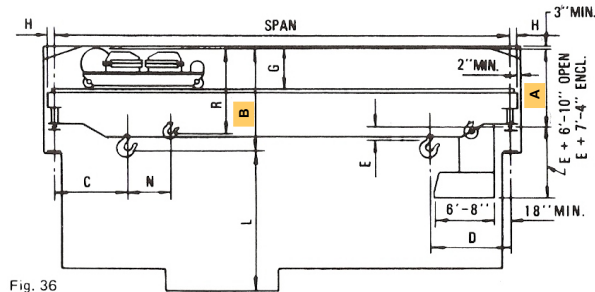

Fig. 36

Rated Load	Span	A	B	C	D	E	G	H	J	K	L
	50'0"	7'2"	8'10"	4'9"	8'0"	1'7"	4'0"	8 3/4"	11'0"	7'0"	33'0"
									12'0"	8'0"	42'4"
									13'0"	9'0"	51'8"
→	60'0"	7'11"	8'10"	4'9"	8'0"	1'7"	4'0"	8 3/4"	11'0"	7'0"	33'0"
									12'0"	8'0"	42'4"
									13'0"	9'0"	51'8"



There's always a solution in steel!

37

TOR Elevation

- Hook to top of crane = 8'-10"
- TOR to top of crane = 7'-11"
- TOR = 45' + (8'-10") - (7'-11") = 45'-11"



There's always a solution in steel!

38

Eave Elevation

- Eave height = hook height + hook to top of crane + clearance to structure + JG depth + joist seat height + deck height
- A good estimate of the Joist Girder depth (inches) is to use the depth equal to the span length in feet. A JG depth of 60 inches will be used.
- Eave height = $45' + (8'-10'') + 3'' + (5'-0'') + 5'' + 1.5'' = 59'-7.5''$ Use 60 ft.



There's always a solution in steel!

39

Design of an Industrial Crane Building

- **Lesson 4**
 - Project Description and Design Criteria
 - Serviceability Requirements
 - Determination of Top of Rail and Eave Elevation
 - **Preliminary Design Calculations**



There's always a solution in steel!

40

Preliminary Design

- **Structural System**

- 60 ft Joist Girders (JG)
- Open web steel joists
- Standing seam metal roof (SSR)
- Moment Frames using JG
 - Moment connections at sidewall columns only
- X-bracing in the longitudinal direction
- Fixed base columns
 - Likely that drift controls
 - Separate crane and building columns (based on a previous study)



There's always a solution in steel!

41

Design of an Industrial Crane Building

- **Basic Seismic Force Resisting Systems**
 - Transverse: Ordinary Moment Frames (OMF)
 - Longitudinal: Ordinary Steel Concentrically Braced Frames (OCBF)



There's always a solution in steel!

42

Preliminary Roof Framing

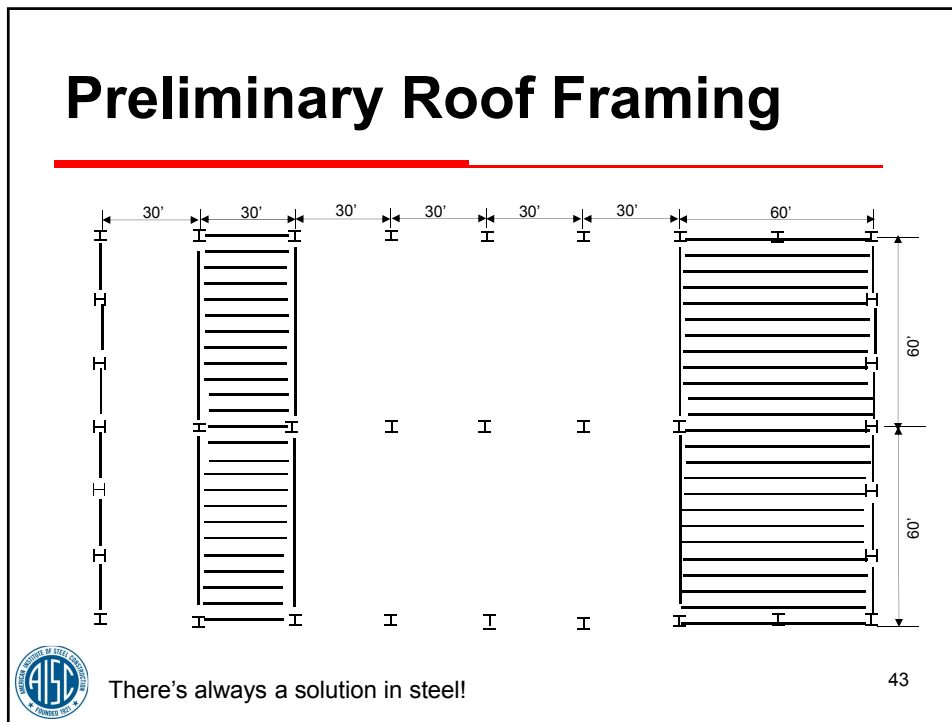

Preliminary Wall Bracing

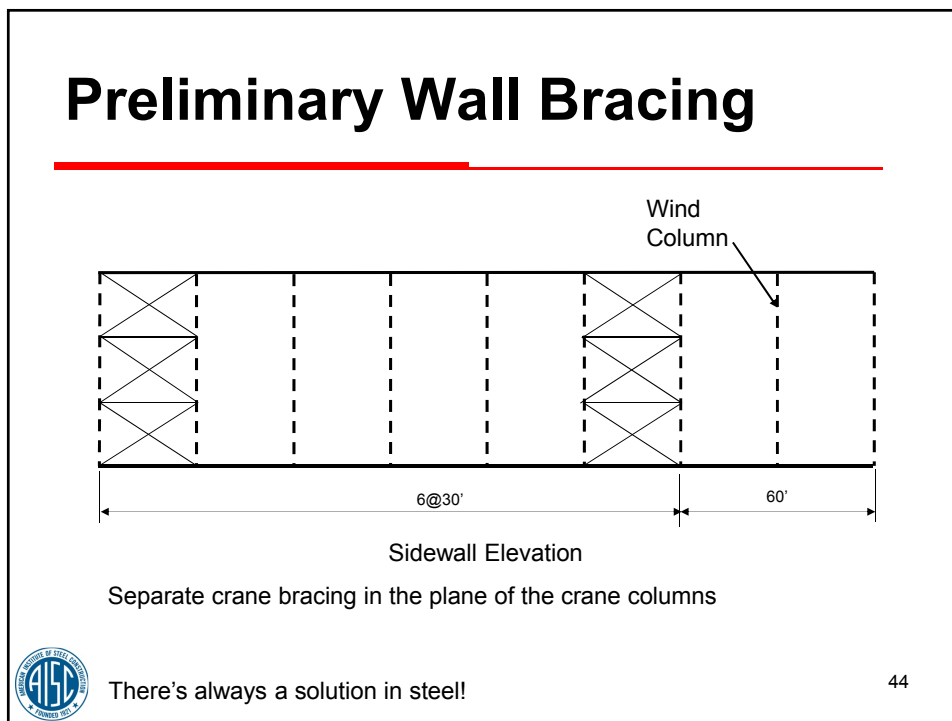

Preliminary Endwall Framing

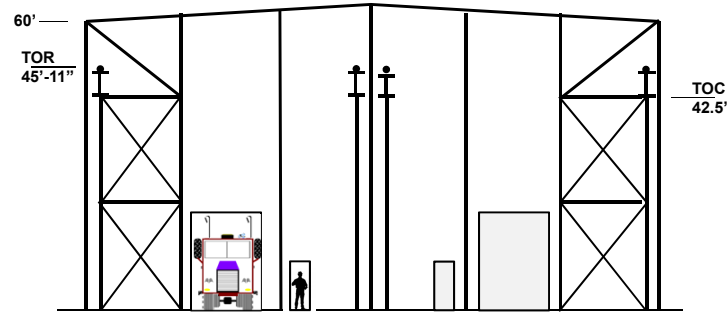

End Wall



There's always a solution in steel!

45

Preliminary Design Sidewall Columns

- An early decision must be made as to the type of columns to be used. Possible column types include:
 - Separate crane and building columns
 - Bracketed columns
 - Stepped columns
 - Composite crane and building columns
 - Composite columns can be achieved by either connecting the crane columns to the building columns with horizontal ties, or by lacing the two columns together.



There's always a solution in steel!

46

Column Types

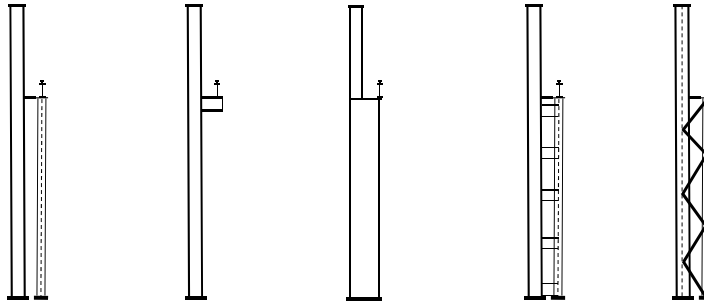

There's always a solution in steel!

47

Column Types

- **Separate Crane Columns**

- Ease of fabrication
- Ship as separate pieces for adjustability of the runway
- No bending in the building column from the crane vertical load
- Lateral deflections result primarily from the loads on the building column



There's always a solution in steel!

48

Preliminary Design of Separate Crane Columns

- Orient the crane column so that bending from the runway girder bends the column about the strong axis
- Tie the crane column to the building column at it's top only, if practical
- Consider the bending eccentricity from the runway reaction equal to the half depth of the crane column
- The column shaft flanges should be approximately the same width as the runway beam flange width



There's always a solution in steel!

49

Column Types

- **Bracketed Columns**
 - Relatively easy to fabricate
 - Bending in the building column from the crane vertical loads
 - Some lateral adjustability for the crane runway
 - Lateral deflections are critical
 - Limitations on bracket strength

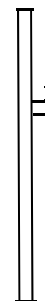

There's always a solution in steel!

50

Preliminary Design of Bracket Crane Columns

- Limit use to crane reactions less than 50 kips
- Select preliminary size based on the lateral deflection of the column
- Design the column considering the portion above the bracket and below the bracket as separate members
- Consider bending of the column about its weak axis
- Eliminate column stiffeners by using heavy column sections
- Consider the inward deflection of the columns as this may cause crane wheel binding



There's always a solution in steel!

51

Column Types

- **Stepped Columns**
 - Relatively easy to fabricate (if clean)
 - Bending in the building column from the crane vertical loads
 - Some lateral adjustability for the crane runway
 - Lateral deflections reduced as compared to separate and bracketed columns



There's always a solution in steel!

52

Preliminary Design of Stepped Crane Columns

- Consider weak axis bending from the runway beam. You may want to add a channel “cap” to the inside column flange
- Select the total section depth based on clearance requirements between the upper shaft and the runway centerline
- Position the crane beam web over the flange of the lower section
- Estimate the flange area of the lower section based on an area equal to $R/[(0.45)(F_y)]$, where R is the runway beam reaction on the column



There's always a solution in steel!

53

Column Types

- **Composite Columns**
 - Costly to fabricate
 - Minor bending in the building column from the crane vertical loads
 - Little lateral adjustability
 - Lateral deflections significantly reduced as compared to separate and bracketed columns
 - Advantages in taller buildings

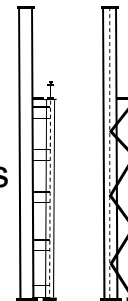

There's always a solution in steel!

54

Preliminary Design of Composite Crane Columns

- Orient upper shaft with web perpendicular to runway and lower shafts with webs parallel to the runway
- Spread lower shafts apart for economy
- Lacing is more economical than diaphragms plates or struts
- Lower column shaft flanges should be approximately the same width as the runway beam flange width

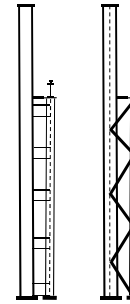

There's always a solution in steel!

55

Selection of Column Type

- See AISC Design Guide 7 for detailed preliminary design suggestions

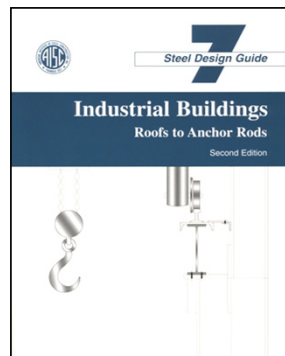

There's always a solution in steel!

56

Selection of Column Type

- For this design example the separate crane column was chosen based on:
 - Cost comparison with composite columns and the stepped column
 - The crane vertical loads are excessive for bracket use (AIST)



There's always a solution in steel!

57

Preliminary Design- Sidewall Columns

Drift for a single column:

$$\Delta = \frac{PH^3}{12EI}$$

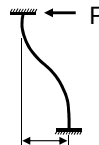

P is the concentrated load at mid-height of the roof truss.

H is the distance from the base to mid-height of the roof truss.

Drift Criteria.

- H/240 for 10 year wind with a 2 in. maximum at the TOR.
- H/100 at the eave.
- By observation for this building 2 in. controls.



There's always a solution in steel!

58

Preliminary Design- Sidewall Columns- 30 ft bays

Using an approximate wind load of 20 psf for the preliminary design, $P =$

$$P_{wind} = (20)(\text{Eave Height}/2)(\text{Bay Spacing})$$

$$P_{wind} = (20)(60/2)(30)/1000 = 18 \text{ kips}$$

$$= 13.5 \text{ kips for a 10 year wind.}$$

Since each column takes $\frac{1}{2}$ of the wind load, the load per column is 6.75 kips.

$$P_{crane} = 10.8 \text{ kips / column}$$

Use the lateral crane load as it is greater than the wind load.

As an approximation apply the crane load at mid-depth of the roof truss.

Use a 6 ft deep truss, and reduce the force at the mid-depth to reflect the difference in elevation between the TOR and the mid-depth of the truss. $P = (45.92/60-6/2)(10.8) = 8.7 \text{ kips}$.

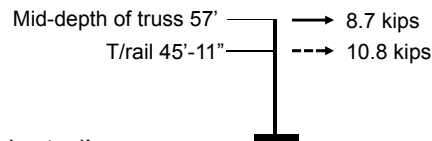

There's always a solution in steel!

59

Preliminary Design- Sidewall Columns- 30 ft bays

For each of the two fixed columns in the frame:

$$I_{xreq'd} = \frac{PH^3}{12E\Delta}$$

$$I_{xreq'd} = \frac{(8.7)(57)^3 (1728)}{(12)(29000)(2.0)} = 4000 \text{ in}^4.$$

Try a W30X99, $I_x = 3990 \text{ in}^4$ (AISC Manual Table 3-3)



There's always a solution in steel!

60

Loads

- ROOF DEAD LOAD

– Roofing (SSR)	2.0 psf
– Insulation	1.0 psf
– Roof Bracing	1.0 psf
– Joists	3.0 psf
– Joist Girders	3.0 psf
– Columns	6.0 psf
– MEP Allowance	3.0 psf
– Total	19.0 psf

- WALL DEAD LOAD

3.0 psf

(Includes Girts) Roofing, Insulation, Roof Bracing, Joists, Joist Girders, MEP = 13psf



There's always a solution in steel!

61

Preliminary Design- Sidewall Columns- 30 ft bays

- Conduct a preliminary drift analysis by modeling a typical frame line. Use ASD for this example.
- The JG moment of inertia based on gravity loads equals $0.027NPLd$, where,

N= # of panel points

P = the panel point load, kips (Roofing, Insulation, Roof Bracing, Joists, Joist Girders, MEP = 13 psf)

$P = (5 \text{ ft})(30 \text{ ft})[(13 \text{ psf}) + (20 \text{ psf})] = 4.95 \text{ kips}$

L = span length, ft

d = depth, in.

- $I = (0.027)(12)(4.95)(60)(60) = 5770 \text{ in.}^4$



There's always a solution in steel!

62

Preliminary Design- Sidewall Columns- 30 ft bays

- The JG size will most likely be controlled by seismic requirements.
- As a single story frame, the Ordinary Moment Frame can be designed as a strong beam weak column system.
- ANSI/AISC 341-10 requires that the Joist Girder to column moment connections in an OMF be designed for a moment equal to $1.1R_yM_p$ of the girder, or the maximum moment that can be developed by the system (see ANSI/AISC 341-10, Section E1.6b).



There's always a solution in steel!

63

Preliminary Design- Sidewall Columns- 30 ft bays

- In this system, where the Joist Girders have more flexural strength than the columns, the fuse in the system is the column, and the maximum force that can be developed by the system is that force which generates the maximum expected moment (M_p) in the column.
- **This requirement is only required in Seismic Design Categories D, E, and F as is the case here, or where $R = 3.5$ is used rather than 3.0 in SDC's B and C.**



There's always a solution in steel!

64

Preliminary Design- Sidewall Columns- 30 ft bays

- Also, single-story steel ordinary moment frames in structures assigned to Seismic Design Category D and E are permitted up to a height of 65 ft when:
 - The dead load supported by, and tributary to, the roof does not exceed 20 psf.
 - And the dead load tributary to the moment frame of the exterior wall more than 35 ft above the base does not exceed 20 psf.



Reference ASCE 12.2.5.7.1

There's always a solution in steel!

65

Preliminary Design- Sidewall Columns- 30 ft bays

- The premise of the OMF frame design for this type of system (strong beam – weak column) is that all columns participating in the lateral load resisting frame have hinged (or developed M_p) just below the bottom chord of the roof trusses.
- Refer to SJI Technical Digest 11 for additional information relative to Joist Girders



There's always a solution in steel!

66

Preliminary Design- Sidewall Columns- 30 ft bays

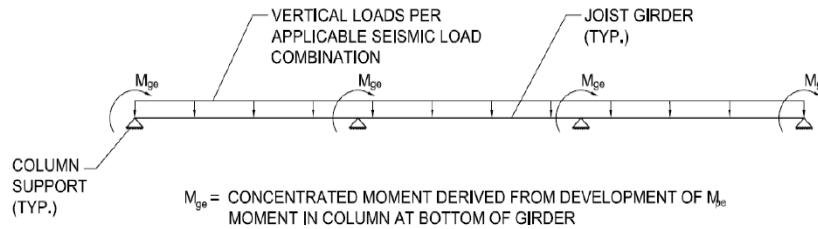

The moment at the girder to column connection is derived by extrapolating the maximum expected moment in the column ($1.1R_yM_p$) to the mid-depth of the girder. This moment is referred to as M_{ge} . At an interior column, where moment connected girders are on both sides of the column, the M_{ge} associated with this column is apportioned to each girder.



There's always a solution in steel!

67

Preliminary Design- Sidewall Columns- 30 ft bays

- Based on the W30X99, the column moment = $1.1R_yM_p = (1.1)(1.1)(1170/0.9) = 1573$ kip-ft. Note: ϕM_p is tabulated in the AISC Manual. To get M_p divide by ϕ .
- $M_{ge} = (57 \text{ ft} / 54 \text{ ft})(1573 \text{ kip-ft}) = 1660$ kip-ft
- Based on this moment, the approximate chord force in the truss is $M/d = (1660)(12)/(58) = 343$ kips, where d equals the approximate effective depth of the truss.
- For JG's the chord size to resist this force is approximately 4X4X5/8 (next slide), based on an unsupported length of 5 ft for the chord. This chord has an area of 9.21 in^2 . The angle size and the chord area are taken from the Table provided in SJI Technical Digest 11 .



There's always a solution in steel!

68

Double Angle Chord Available Strength (LRFD) for Various Unbraced Lengths, kips ($F_y = 50$ ksi, $\phi = 0.90$)

Angle Size	Unbraced Length				Area in. ²
	L = 4 ft.	L = 5 ft.	L = 6 ft.	L = 7 ft.	
2L 4 x 4 x 3/4	434	406	373	338	10.9
2L 4 x 4 x 5/8	368	345	318	289	9.21
2L 4 x 4 x 1/2	300	281	260	236	7.49
2L 4 x 4 x 7/16	262	249	230	210	6.61
2L 4 x 4 x 3/8	216	211	200	182	5.71
2L 4 x 4 x 5/16	144	143	143	141	4.80
2L 4 x 4 x 1/4	92	92	92	91	3.87

Only a portion of the table is shown
Table is courtesy of the Steel Joist Institute



There's always a solution in steel!

69

Preliminary Design- Sidewall Columns- 30 ft bays

- The approximate moment of inertia of the JG or truss is $(0.85)(2)Ad^2 = (0.85)(2)(9.21)(29)^2 = 13,167$ in⁴.
- The 0.85 factor is a reduction in the moment of inertia due to web member strains.
- The centroid distance to the top and bottom chord from the centroid is estimated to be 29 in.
- The computer model can now be constructed.



There's always a solution in steel!

70

Preliminary Design- Sidewall Columns- 30 ft bays

- The Model
 - Beam elements were used to represent the trusses.
 - The elevation of the beam elements is taken as the mid-depth of the trusses (57 ft).
- Results
 - Crane lateral, TOR deflection = 2.35 in. > 2.0 in.



There's always a solution in steel!

71

Preliminary Design- Center Columns- 30 ft bays

- The center column has no affect on the first order drift of the frame (pinned ends); however, the added bending in the column due to the crane lateral load is additive to the frame drift. Due to slenderness considerations a W24X104 was used in the model ($l/r = (12)(40)/(2.91) = 165$).
- The deflection in the W24X104 at the TOR was determined to be 2.50 in.



There's always a solution in steel!

72

Preliminary Design- Center Columns- 30 ft bays

- Since the deflection limits were exceeded a second trial was conducted using W30X116 sidewall columns and a W24X146 center column.
- Results for Sidewall Columns
 - Crane lateral, TOR deflection = 1.92 in. < 2.0 in.
- Results for Center Column
 - Crane lateral, TOR deflection = 1.99 in. < 2.0 in.



There's always a solution in steel!

73

Preliminary Design- Center Columns- 30 ft bays

- Summary of Preliminary Design Results
 - Sidewall Columns: W30X116
 - Center Column: W24X146
 - The truss or JG weight is estimated using 2.5 times the chord weight.
$$= (2.5)(9.21 \text{ in.}^2)(3.4 \text{ lbs/in.}^2/\text{ft}) = 78 \text{ lbs/ft}$$



There's always a solution in steel!

74

Preliminary Design- Sidewall Columns- 30 ft bays

- Determine if it would be economical to engage the center column as a part of the OMF.
 - The sum of the moment of inertias for the W30x116 columns is 9860 in^4 , thus any solution using the center column would have to provide a similar summation.
 - The moment of inertia of the W24X146 is 4580 in^4 , thus the sidewall columns each require a moment of inertia of approximately 2640 in^4 .
 - Try a W24X84, $I_x = 2370 \text{ in}^4$.
 - The W24X84 ($M_p = 933 \text{ kip-ft}$) controls the truss size because the M_p requirement of the W24X146 (1744 kip-ft) is divided equally to each of the truss framing to it.
 - The truss has an $I_x = 9450 \text{ in}^4$.



There's always a solution in steel!

75

Preliminary Design- Sidewall Columns- 30 ft bays

- Based on the computer model the deflection criterion at the TOR is $2.0 \leq 2.0 \text{ in}$.
- W24X84 sidewall columns are required.
- This solution has a weight savings of approximately (3840 lbs); as compared to the frame with a pinned ended center column; however, the weight savings may be offset by the added erection cost of the moment connection at the column, and the larger moment footing under the center column.



There's always a solution in steel!

76

Preliminary Design- Sidewall Columns- 30 ft bays

- Only the crane and wind lateral loads have been considered thus far in the preliminary design.
- Due to the location of the structure it is anticipated that the seismic loads may control the final design. The seismic loads are considered in Lecture 5.
- The solution using the center column as a part of the OMF will be used. This solution has greater flexibility for choosing member sizes and controlling seismic drifts.



There's always a solution in steel!

77

Bay Spacing

- Would a bay spacing greater than 30 ft be more economical?
 - Study a 40 ft bay spacing for comparison.



There's always a solution in steel!

78

Layout

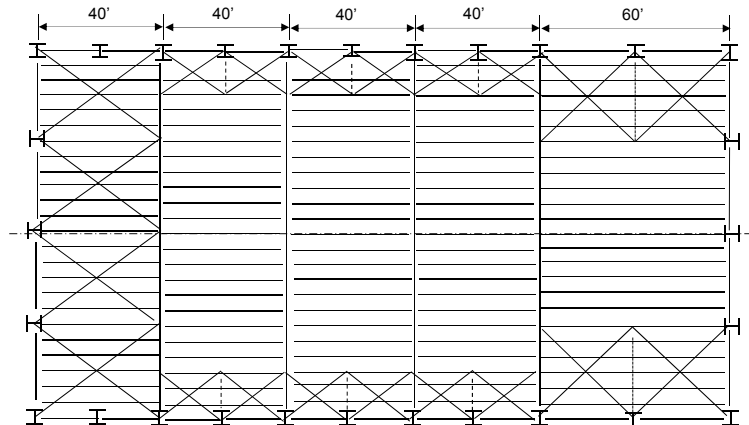

There's always a solution in steel!

79

Preliminary Design- Sidewall Columns- 40 ft bays

- A similar analysis was conducted for the 40 ft bay.
 - W24X94 sidewall columns were required.
 - A W24X146 center column was required.
 - The JG or truss weight was taken as 78 plf
 - The deflection at the TOR = 1.92 in.



There's always a solution in steel!

80

Wind Columns- 40 ft bays

- Since cold-formed girts are being used wind columns will be required for the 40 ft bay solution.
- Wind column design is not shown for brevity. **Use W18X40**



There's always a solution in steel!

81

Preliminary Design

- Joist Weights
 - Load per ft = $(5)(14 + 20) = 170$ plf
 - 30 ft bay: 18K3, Wt. = 6.6 plf
 - 40 ft bay: 22K4, Wt. = 8.0 plf



There's always a solution in steel!

82

Preliminary Crane Runways

- Two runway beam designs were conducted for the 30 ft and 40 ft bays.
- A plain beam solution and a combined section solution.
- The designs were conducted using an in-house program.
- A detailed hand calculation is provided in Lesson 5.



There's always a solution in steel!

83

Preliminary Crane Runways

- 30 ft span:
 - W36X230, or a W36135 w/ MC18X42.7
- 40 ft span:
 - W36X359
- A fabricators cost input indicated that the plain beam solutions were the most economical.



There's always a solution in steel!

84

Frame Weight Summary

Member Type	30 ft Bay		40 ft Bay	
	Size	Weight, lbs	Size	Weight, lbs
Sidewall Columns	W24X84	10,080	W24X94	11,280
Center Column	W24X146	8,760	W24x146	8,760
Crane Columns	W14X109	17,440	W14X109	17,440
Trusses	56 (plf)	6,720	64 (plf)	7,680
Joists	1.32 (#/sq.ft)	4,750	1.60 (#/sq.ft)	7,680
Runway Beams	W36X231	27,600	W36X361	57,440
Wind Columns	NA	-	W24X68	8,160
Total Weight		75,400		118,400
Total Weight		21.0 (#/sq.ft)		24.7 (#/sq.ft)



There's always a solution in steel!

85

Frame Weight Summary

- Even with the cost saving of the footings for the 40 ft bay structure, the 30 ft bays appear to be more economical.
- In addition, the bracing required for the wind columns for the 40 ft bays, would be expensive to erect



There's always a solution in steel!

86

End of Lesson 4



There's always a solution in steel!

87

Individual Webinar Registrants

PDH Certificates
Within 2 business days...

- You will receive an email on how to report attendance from: registration@aisc.org.
- Be on the lookout: Check your spam filter! Check your junk folder!
- Completely fill out online form. Don't forget to check the boxes next to each attendee's name!



There's always a solution in steel!

Individual Webinar Registrants

PDH Certificates

Within 2 business days...

- New reporting site (URL will be provided in the forthcoming email).
- Username: Same as AISC website username.
- Password: Same as AISC website password.



There's always a solution in steel!

8-Session Registrants

PDH Certificates

One certificate will be issued at the conclusion of
all 8 sessions.



There's always a solution in steel!

8-Session Registrants

QUIZZES

Access to the quiz: Information for accessing the quiz will be emailed to you by Wednesday. It will contain a link to access the quiz. EMAIL COMES FROM NIGHTSCHOOL@AISC.ORG

Quiz and Attendance records: Posted Tuesday mornings. www.aisc.org/nightschool - scroll down to Quiz and Attendance Records.

Reasons for quiz:

EEU – must take all quizzes and final to receive EEU

PDHS – If you watch a recorded session you must take quiz for PDHs.

REINFORCEMENT – Reinforce what you learned tonight. Get more out of the course.

NOTE: If you attend the live presentation, you do not have to take the quizzes to receive PDHs.



There's always a solution in steel!

8-Session Registrants

RECORDINGS

Access to the recording: Information for accessing the recording will be emailed to you by this Wednesday. The recording will be available for two weeks. For 8-session registrants only. EMAIL COMES FROM NIGHTSCHOOL@AISC.ORG.

PDHS – If you watch a recorded session you must take AND PASS the quiz for PDHs.



There's always a solution in steel!

Night School Resources for 8-session package Registrants

Find all your handouts, quizzes and quiz scores, recording access, and attendance information all in one place!



There's always a solution in steel!

Night School Resources for 8-session package Registrants

Go to www.aisc.org and sign in.



Login

If you're an existing customer, please enter your username and password.

USERNAME

Enter your username

PASSWORD

Enter your password

Remember Me

DON'T HAVE AN ACCOUNT?

My AISC allows you to access Engineering Journal articles and Design Guides you have downloaded from the bookstore.

[REGISTER NOW](#)

Night School Resources for 8-session package Registrants

IN THIS SECTION

- Edit Profile
- My Downloads
- My Pending Quizzes
- My Events
- Order History
- Course History
- Night School Resources

MyAISC

MY PROFILE
Update your contact and address information.

[EDIT PROFILE](#)

MY PURCHASED DOWNLOADS
Access articles and documents that you have purchased.

MY ORDER HISTORY
View your past orders.

[VIEW ORDERS](#)

MY NIGHT SCHOOL RESOURCES
View online resources for Night School courses, available for 8-Session Package registrants. See www.aisc.org/nightschool for information on Night School including registration.

[\[VIEW RESOURCES\]\(#\)](#)

Night School Resources for 8-session package Registrants

EDUCATION
PUBLICATIONS
NASCC: THE STEEL CONFERENCE
SAFETY
STEEL SOLUTIONS CENTER
AWARDS AND COMPETITIONS



AISC

AISC > MYAISC > NIGHT SCHOOL RESOURCES

Night School Resources

Event	Date
NS 13 8-Session Package	1/30/2017 7:00:00 PM



There's always a solution in steel!

Night School Resources for 8-session package Registrants



Night School 13: Design of Industrial Buildings

8-SESSION PACKAGE RESOURCES

Event	Date	Handouts	Video	Quiz	Attendance
NS13 - Design Criteria	1/30/2017 7:00:00 PM	Handouts	Video Passcode: NS13DSN	Pass Score: 80	Pending
NS13 - Economic Considerations	2/6/2017 7:00:00 PM	Handouts	Available 02/08/2017 5pm EST	Available 02/08/2017 5pm EST	Pending
NS13 - Lateral Load Systems and Details	2/13/2017 7:00:00 PM	Handouts	Available 02/15/2017 5pm EST	Available 02/15/2017 5pm EST	Pending
NS13 - Preliminary Design Procedures	2/27/2017 7:00:00 PM	Handouts	Available 03/01/2017 5pm EST	Available 03/01/2017 5pm EST	Pending
NS13 - Crane Girder Design and Frame Analysis	3/6/2017 7:00:00 PM	Handouts	Available 03/08/2017 5pm EST	Available 03/08/2017 5pm EST	Pending
NS13 - Frame Member and Connection Design	3/13/2017 7:00:00 PM	Handouts	Available 03/15/2017 5pm EST	Available 03/15/2017 5pm EST	Pending
NS13 - Transfer Crane Girder & Longitudinal Bldg Bracing Dsn	3/27/2017 7:00:00 PM	Handouts	Available 03/29/2017 5pm EST	Available 03/29/2017 5pm EST	Pending
NS13 - Building Envelope and Bracing Design	4/3/2017 7:00:00 PM	Handouts	Available 04/05/2017 5pm EST	Available 04/05/2017 5pm EST	Pending
NS13 - Final Exam	4/10/2017 7:00:00 PM			Available 04/12/2017 5pm EST	

Night School Resources for 8-session package Registrants

- Weekly “quiz and recording” email.
- Weekly updates of the master Quiz and Attendance record found at www.aisc.org/nightschool. Scroll down to Quiz and Attendance records.
 - Updated on Tuesday mornings.



There's always a solution in steel!

Night School Resources for 8-session package Registrants

- Webinar connection information:
 - Found in your registration confirmation/receipt.
 - Reminder email sent out Monday mornings.
- Link to handouts also found here.



There's always a solution in steel!

Thank You

Please give us your feedback!
Survey at conclusion of webinar.

There's always a solution in steel.

