



Thank you for joining our live webinar today.
We will begin shortly. Please standby.

Thank you.

Need Help?
Call ReadyTalk Support: 800.843.9166



Today's audio will be broadcast through the internet.

Alternatively, to hear the audio through the phone, dial 888 224 7958.



There's always a solution in steel!



Today's live webinar will begin shortly.
Please standby.
As a reminder, all lines have been muted. Please type any questions or comments through the Chat feature on the left portion of your screen.

Today's audio will be broadcast through the internet.
Alternatively, to hear the audio through the phone, dial 888 224 7958.



There's always a solution in steel!



AISC is a Registered Provider with The American Institute of Architects Continuing Education Systems (AIA/CES). Credit(s) earned on completion of this program will be reported to AIA/CES for AIA members. Certificates of Completion for both AIA members and non-AIA members are available upon request.

This program is registered with AIA/CES for continuing professional education. As such, it does not include content that may be deemed or construed to be an approval or endorsement by the AIA of any material of construction or any method or manner of handling, using, distributing, or dealing in any material or product.

Questions related to specific materials, methods, and services will be addressed at the conclusion of this presentation.



There's always a solution in steel!



Copyright Materials

This presentation is protected by US and International Copyright laws. Reproduction, distribution, display and use of the presentation without written permission of AISC is prohibited.

© The American Institute of Steel Construction 2017

The information presented herein is based on recognized engineering principles and is for general information only. While it is believed to be accurate, this information should not be applied to any specific application without competent professional examination and verification by a licensed professional engineer. Anyone making use of this information assumes all liability arising from such use.



There's always a solution in steel!



Course Description

Session 6: Frame Member and Connection Design
March 13, 2017

Lesson 6 incorporates the results of the frame analysis discussed in lesson 5 to demonstrate the design of the building columns, crane columns, and moment connections. The AISC Manual beam-column tables are used for the design of the beam columns to illustrate their use. The design of the Ordinary Moment Frame connection of a truss to the building column is provided. The development of the specification for the joist girders for the example building using the Steel Joist Institute's Technical Digest 11 is also discussed. The design of the column anchor rods is provided including evaluation of limit states according to ACI 318 Chapter 17. Discussion of the recommendations of AISC Design Guide 1 are included in the example as well as the calculation for the thickness of the column base plate.



There's always a solution in steel!



Learning Objectives

- Discuss how the results of a frame analysis are used to design columns, crane columns and moments connections.
- List where column and beam-column design values are found in the AISC Steel Construction Manual.
- List the requirements of an Ordinary Moment Frame design per AISC 341-10.
- List the criteria to establish the length and diameter of column anchor rods.



There's always a solution in steel!



Design of Industrial Buildings

Session 6: Frame Member and Connection Design

March 13, 2017



Presented by
Jules Van de Pas, SE, PE
Vice President, Computerized Structural Design

There's always a solution in steel.



AISC Night School 13

Design of Industrial Buildings Lesson 6

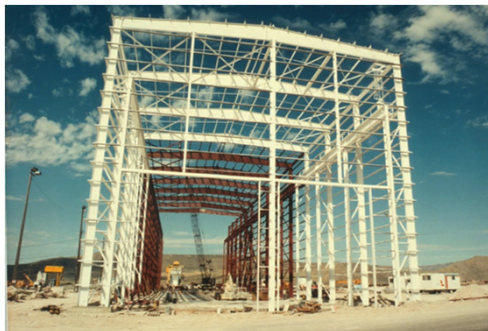

Presenter:
Jules Van de Pas



There's always a solution in steel!

Design of an Industrial Crane Building

• Lesson 6

- Final Design of the Building Columns
- Final Design of the Crane Columns
- Final Design of the Truss
- Design of the Frame Connections
- Design of the Anchor Rods



There's always a solution in steel!

10

Review of Design Criteria



There's always a solution in steel!

11

Project Description

- 50 ton, top running crane, Class D
- Quantity: 1 per aisle
- Hook height: 45 ft
- Roof type: Standing Seam on Joists
- Wall type: R- panel with continuous Zs
- Automatic Sprinkler System



There's always a solution in steel!

12

Codes and Standards

- Building Code: IBC 2015
- Minimum Design Loads For Buildings And Other Structures (ASCE 7-10)
- Building Department Contact: John Smith
- Date: July 6, 2016
- Local Ordinances: None
- Wind Speed: 115 mph
- Wind Exposure: C



There's always a solution in steel!

13

Local Code Requirements

- Ground Snow Load: 15 psf
- Seismic Spectral Acceleration:
 - $S_s = 1.054 g$
 - $S_1 = 0.400 g$



There's always a solution in steel!

14

Loads

- ROOF DEAD LOAD
 - Roofing (SSR) 2.0 psf
 - Insulation 1.0 psf
 - Roof Bracing 1.0 psf
 - Joists 3.0 psf
 - Joist Girders 3.0 psf
 - Columns 6.0 psf
 - MEP Allowance 3.0 psf
 - **Total 19.0 psf**
- WALL DEAD LOAD **3.0 psf**
(Includes Girts)



There's always a solution in steel!

15

Loads

- ROOF LIVE LOADS
 - 20.0 psf (reducible)
- SNOW LOADS
 - Ground Snow Load (P_g): 15.0 psf
 - Building Category: II \rightarrow Importance Factor, $I_s = 1.0$
 - Thermal Factor, C_t : 1.0
 - Exposure Factor, C_e , Partially Exposed: 1.0



There's always a solution in steel!

Load Calculations - Snow

- Low Slope Roof Snow Load (slope $< 15^\circ$):
 $P_f = 0.7C_e C_t I P_g = 10.5 \text{ psf}$
- Minimum Roof Snow for Low Slope Roof
 $P_m = I_s P_g = 15 \text{ psf}$ ← controls
- Check Rain-on-Snow Surcharge, slope $\frac{1}{4}$ " per ft.
 (Slope = 1.19°) $<$ ($W / 50 = 60 / 50 = 1.2$) Add Surcharge
 → $P_f = 15 \text{ psf} + 5 \text{ psf} = 20 \text{ psf}$
- Must consider unbalanced snow per 7.6 if slope is $\frac{1}{2}$ " per ft or greater.



There's always a solution in steel!

17

Loads

- SEISMIC LOADS
 - Spectral Acceleration, S_s : 1.054 g
 - Spectral Acceleration, S_1 : 0.40 g
 - Occupancy Category: II
 - Site Class: D
 - Soil shear wave velocity, \bar{v}_s : 800 ft/sec
 - Standard penetration resistance, \bar{N} : 15 blows
 - Soil undrained shear strength, $\bar{\tau}_u$: 1500 psf
 - Importance Factor, I_e : 1.0
 - Seismic Design Category: D



There's always a solution in steel!

18

Load

- Structure is considered to be a “Nonbuilding Structure Similar to Buildings” per Chapter 15 of ASCE 7-10
- Transverse Direction from Table 15.4-1 OMF – Ordinary Moment Frame with permitted height increase
 $R = 2.5$ $\Omega_o = 2.0$ $C_d = 2.5$
Detailing per AISC 341 Height limit = 100 feet.
- Longitudinal Direction from Table 15.4-1 OCBF – Ordinary Concentrically Braced Frame with permitted height increase
 $R = 2.5$ $\Omega_o = 2.0$ $C_d = 2.0$
Detailing per AISC 341 Height limit of 160 ft.



There's always a solution in steel!

Design of an Industrial Crane Building

- **Lesson 6**
 - Final Design of the Building Columns
 - Final Design of the Truss
 - Design of the Frame Connections
 - Design of the Anchor Rods



There's always a solution in steel!

20

Column Design

- Check preliminary building column sizes for forces and moments from the analysis.
- Reanalyze if column sizes change, including adjusted joist girder properties
- Re-check members
- Check drift (serviceability and seismic)
- Final design of the crane columns



There's always a solution in steel!

21

Design of Beam Columns

- Beam Column Design using Manual Tables
 - Part 6 of the Manual contains tables to assist in the design of members for combined forces
 - Table entries included for all W-shapes
 - Could actually be used to design for pure bending, pure compression, and pure tension
 - Available for W-shapes only
 - Includes ALL W-shapes



There's always a solution in steel!

22

Design for Combined Forces

- Interaction Equations

For $\frac{P_r}{P_c} \geq 0.2$

- H1-1a and H1-1b

$$\frac{P_r}{P_c} + \frac{8}{9} \left[\frac{M_{rx}}{M_{cx}} + \frac{M_{ry}}{M_{cy}} \right] \leq 1.0$$

For $\frac{P_r}{P_c} < 0.2$

$$\frac{P_r}{2P_c} + \left[\frac{M_{rx}}{M_{cx}} + \frac{M_{ry}}{M_{cy}} \right] \leq 1.0$$



There's always a solution in steel!

23

Design for Combined Forces

- These may be rewritten as

$$pP_r + b_x M_{rx} + b_y M_{ry} \leq 1.0 \quad (\text{H1-1a})$$

and

$$0.5pP_r + \frac{9}{8} (b_x M_{rx} + b_y M_{ry}) \leq 1.0 \quad (\text{H1-1b})$$

respectively



There's always a solution in steel!

24

Design for Combined Forces

• Where

$$p = \frac{1}{P_c}$$

$$b_x = \frac{8}{9M_{cx}}$$

$$b_y = \frac{8}{9M_{cy}}$$

Units are 1/kips and 1/ft-kips



There's always a solution in steel!

AISC Manual Table 6-1

Table 6-1 (continued)
Combined Axial
and Bending
 $F_y = 50$ ksi
W Shapes

Shape	W14								
	W14				W16				
	90°		74°		90°		74°		
Design	$p \times 10^2$ (kip-ft) ²	$b_x \times 10^3$ (kip-ft) ²	$p \times 10^2$ (kip-ft) ²	$b_x \times 10^3$ (kip-ft) ²	$p \times 10^2$ (kip-ft) ²	$b_x \times 10^3$ (kip-ft) ²	$p \times 10^2$ (kip-ft) ²	$b_x \times 10^3$ (kip-ft) ²	
8	1.33	0.802	2.33	1.55	1.55	1.03	2.56	1.71	1.14
9	1.38	0.844	2.33	1.55	1.60	1.06	2.57	1.73	1.17
10	1.36	0.807	2.33	1.55	1.65	1.10	2.61	1.74	1.21
11	1.38	0.801	2.33	1.55	1.71	1.14	2.66	1.77	1.26
12	1.41	0.850	2.33	1.55	1.76	1.18	2.70	1.80	1.31
13	1.44	0.856	2.33	1.55	1.85	1.25	2.75	1.83	1.36
14	1.47	0.876	2.33	1.55	1.94	1.29	2.79	1.86	1.43
15	1.50	0.898	2.33	1.55	2.04	1.36	2.84	1.90	1.50
16	1.54	1.00	2.35	1.57	2.15	1.43	2.89	1.92	1.58
17	1.58	1.05	2.38	1.59	2.26	1.52	2.94	1.96	1.67
18	1.62	1.09	2.42	1.61	2.42	1.61	3.00	2.00	1.78
19	1.67	1.11	2.45	1.63	2.58	1.71	3.05	2.05	1.89
20	1.72	1.14	2.48	1.65	2.75	1.83	3.11	2.07	2.02
22	1.83	1.27	2.58	1.76	3.18	2.17	3.29	2.15	2.34
24	1.97	1.31	2.62	1.74	3.75	2.45	3.37	2.24	2.74
26	2.12	1.41	2.70	1.79	4.38	2.91	3.51	2.34	3.22
28	2.31	1.53	2.78	1.85	5.08	3.38	3.67	2.44	3.79
30	2.52	1.68	2.86	1.91	5.83	3.88	3.84	2.55	4.42
32	2.77	1.85	2.95	1.97	6.63	4.41	4.03	2.68	5.12
34	3.02	2.04	3.05	2.04	7.48	4.98	4.24	2.82	5.88

Other Constants and Properties

$b_x \times 10^3$ (kip-ft) ²	4.90	3.26	7.95	3.29	8.80	5.85
$b_y \times 10^3$ (kip-ft) ²	1.26	0.840	1.29	0.904	1.53	1.02
$r_x \times 10^3$ (kip-ft) ²	1.55	1.03	1.71	1.14	1.88	1.26
$r_y \times 10^3$ (kip-ft) ²	1.85		2.44		2.44	

*Shape does not meet compactness limit for flexure with $F_y = 50$ ksi.



There's always a solution in steel!



Table 6-1

- See AISC Manual page 6-4
 - If $C_b = 1.0$ no adjustments are necessary to use Table 6-1.
 - If $C_b \geq 1.0$, then select b_x from Table 6-1 using L_b and then divide b_x by C_b for checking the section. ($b_x / C_b > b_{xmin.}$)
 - If $pP_r < 0.2$ then divide p by 2 and multiply b_x by 9/8 for checking the section.



There's always a solution in steel!

27

AISC Manual Table 6-1

Shape	W30-W27						W27-W					
	90°			90°			90°			90°		
	$p < 10^3$	$b_x < 10^3$	$b_x < 10^3$	$p < 10^3$	$b_x < 10^3$	$b_x < 10^3$	$p < 10^3$	$b_x < 10^3$	$b_x < 10^3$	$p < 10^3$	$b_x < 10^3$	$b_x < 10^3$
Design	(kip-ft) ¹	(kip-ft) ¹	(kip-ft) ¹	(kip-ft) ¹	(kip-ft) ¹	(kip-ft) ¹	(kip-ft) ¹	(kip-ft) ¹	(kip-ft) ¹	(kip-ft) ¹	(kip-ft) ¹	(kip-ft) ¹
	ASD	LFRD	ASD	LFRD	ASD	LFRD	ASD	LFRD	ASD	LFRD	ASD	LFRD
0	1.31	0.872	1.14	0.760	1.49	0.994	1.26	0.838	0.210	0.140	0.189	0.125
11	1.63	1.08	1.27	0.846	1.95	1.23	1.41	0.968	0.230	0.154	0.189	0.125
12	1.70	1.13	1.31	0.874	1.93	1.28	1.45	0.988	0.226	0.157	0.189	0.125
13	1.79	1.19	1.36	0.903	2.02	1.35	1.51	1.00	0.240	0.160	0.189	0.125
14	1.89	1.26	1.41	0.933	2.13	1.42	1.56	1.04	0.245	0.163	0.189	0.125
15	2.01	1.33	1.48	0.969	2.26	1.50	1.62	1.08	0.250	0.167	0.189	0.125
16	2.14	1.43	1.55	1.01	2.41	1.60	1.68	1.12	0.255	0.171	0.189	0.125
17	2.30	1.53	1.67	1.04	2.59	1.72	1.75	1.16	0.264	0.176	0.189	0.125
18	2.50	1.66	1.83	1.09	2.79	1.86	1.85	1.21	0.273	0.181	0.189	0.125
19	2.73	1.81	1.97	1.15	3.05	2.02	1.93	1.27	0.278	0.186	0.189	0.125
20	3.00	1.98	2.19	1.22	3.37	2.19	2.07	1.32	0.286	0.192	0.189	0.125
22	3.63	2.41	2.60	1.50	4.04	2.69	2.29	1.52	0.308	0.205	0.189	0.125
24	4.31	2.87	3.20	1.84	4.80	3.20	2.65	1.78	0.331	0.220	0.201	0.134
26	5.06	3.37	3.69	2.19	5.64	3.75	3.06	2.02	0.358	0.238	0.205	0.135
28	5.87	3.91	4.29	2.59	6.54	4.35	3.44	2.29	0.390	0.260	0.206	0.137
30	6.74	4.49	4.94	3.22	7.51	4.99	3.95	2.56	0.428	0.285	0.208	0.139
32	7.67	5.10	5.69	3.88	8.54	5.68	4.27	2.84	0.472	0.314	0.213	0.140
34	8.66	5.76	6.36	4.60	9.64	6.41	4.70	3.13	0.524	0.348	0.213	0.142
36									0.586	0.390	0.216	0.144
38									0.653	0.435	0.219	0.146
40									0.724	0.481	0.222	0.148
42									0.798	0.531	0.225	0.149
44									0.876	0.583	0.228	0.151
46									0.957	0.637	0.231	0.154
48									1.04	0.693	0.234	0.156
50									1.13	0.752	0.237	0.158



There's always a solution in steel!

28

Table 6-1

- Exterior columns: W30x99 $P_r = 16.9$ kips, $M_r = 359$ kip- ft
- Since the column has large bending moments compared to axial forces check first by using the beam Table 3-10. Try an unbraced length of 20 ft.

$$p \times 10^3 = 3.00; b_x \times 10^3 = 1.78$$

$$pP_r = (3 \times 10^{-3})(16.9) = (0.003)(16.9) = .051 < 0.2$$

$$(1/2)(.003)(16.9) + (9/8)(0.00178)(359 \text{ kip} - \text{ft}) = .74$$

$$.74 < 1.0 \text{ OK}$$



There's always a solution in steel!

29

Table 6-1

- Interior columns: W24x146 $P_a = 29.3$ kips, $M_a = 430$ kip- ft.
- Laterally braced at top of crane column = 42.5 ft.

$$p \times 10^3 = 4.45; b_x = 1.88 \times 10^{-3}$$

$$pP_a = (4.45 \times 10^{-3})(29.3) = (0.00445)(29.3) = 0.13 < 0.2$$

$$(1/2)pP_r + 9/8(b_x M_{rx} + b_y M_{ry}) \leq 1.0$$

$$(.5)(0.00445)(29.3 \text{ kips}) + (9/8)(.00188)(430 \text{ kip} - \text{ft}) =$$

$$.97 < 1.00 \text{ OK} \text{ -demonstrate adjustment for } C_b$$



There's always a solution in steel!

30

AISC Manual Table 6-1

Table 6-1 (continued)
 Combined Flexure and Axial Force
 W-Shapes

$F_y = 50 \text{ ksi}$



Shape	W24											
	176				162				146			
	$P_r \times 10^3$		$M_r \times 10^3$		$P_r \times 10^3$		$M_r \times 10^3$		$P_r \times 10^3$		$M_r \times 10^3$	
Design	(kip-ft)	(kip-ft)	(kip-ft)	(kip-ft)	(kip-ft)	(kip-ft)	(kip-ft)	(kip-ft)	(kip-ft)	(kip-ft)	(kip-ft)	
0	0.646	0.430	0.697	0.464	0.699	0.465	0.761	0.509	0.777	0.517	0.852	0.507
11	0.742	0.483	0.700	0.466	0.801	0.533	0.764	0.508	0.894	0.585	0.857	0.571
12	0.761	0.506	0.710	0.472	0.822	0.547	0.776	0.516	0.918	0.611	0.872	0.580
13	0.783	0.521	0.721	0.479	0.846	0.563	0.788	0.524	0.945	0.629	0.887	0.590
14	0.808	0.537	0.731	0.487	0.872	0.580	0.801	0.533	0.976	0.649	0.903	0.603
15	0.835	0.555	0.743	0.494	0.901	0.600	0.814	0.541	1.01	0.671	0.918	0.611
16	0.865	0.575	0.754	0.502	0.934	0.621	0.827	0.550	1.05	0.696	0.935	0.622
17	0.898	0.597	0.766	0.510	0.969	0.645	0.841	0.560	1.09	0.723	0.952	0.633
18	0.934	0.622	0.778	0.518	1.01	0.671	0.855	0.569	1.13	0.753	0.970	0.645
19	0.975	0.649	0.791	0.526	1.05	0.700	0.870	0.579	1.18	0.786	0.988	0.657
20	1.02	0.678	0.804	0.535	1.10	0.731	0.886	0.589	1.24	0.823	1.01	0.670
22	1.12	0.746	0.832	0.553	1.21	0.804	0.918	0.611	1.36	0.907	1.05	0.697
24	1.25	0.826	0.861	0.572	1.34	0.892	0.953	0.634	1.52	1.01	1.09	0.727
26	1.40	0.928	0.893	0.594	1.50	0.989	0.991	0.660	1.70	1.13	1.14	0.759
28	1.58	1.05	0.927	0.617	1.70	1.13	1.03	0.687	1.93	1.29	1.19	0.794
30	1.81	1.20	0.964	0.641	1.94	1.29	1.08	0.716	2.21	1.47	1.25	0.832
32	2.05	1.37	1.00	0.668	2.21	1.47	1.13	0.749	2.52	1.68	1.31	0.874
34	2.32	1.54	1.05	0.697	2.49	1.66	1.18	0.784	2.84	1.89	1.39	0.926
36	2.60	1.73	1.09	0.728	2.79	1.86	1.24	0.826	3.19	2.12	1.50	1.00
38	2.91	1.93	1.15	0.767	3.11	2.07	1.33	0.866	3.55	2.36	1.62	1.08
40	3.21	2.13	1.23	0.818	3.45	2.29	1.42	0.947	3.93	2.62	1.73	1.15
42	3.54	2.35	1.31	0.869	3.80	2.53	1.51	1.028	4.34	2.89	1.85	1.23
44	3.88	2.58	1.38	0.920	4.17	2.78	1.60	1.107	4.76	3.17	1.96	1.30
46	4.24	2.82	1.46	0.970	4.56	3.03	1.69	1.193	5.20	3.46	2.07	1.38
48	4.62	3.07	1.53	1.02	4.96	3.30	1.78	1.19	5.67	3.77	2.19	1.45
50	5.01	3.34	1.61	1.07	5.39	3.58	1.87	1.25	6.15	4.09	2.30	1.53



There's always a solution in steel!

Table 6-1

- Interior columns: W24x146 $P_r = 29.3 \text{ kips}$, $M_r = 430 \text{ kip-ft}$
- Laterally braced at top of crane column = 42.5 ft

$$P_r \times 10^3 = 4.45; b_x = 1.88 \times 10^{-3}$$

Say $C_b = 1.75$ (from evaluation of moment diagram)

$$b_x = 1.88 \times 10^{-3} / 1.75 = 1.07 \times 10^{-3} > b_{x(\min)} = 0.852 \times 10^{-3}$$

$$(.5)(0.00445)(29.3 \text{ kips}) + (9/8)(.00107)(430 \text{ kip-ft}) =$$

$$.59 \leq 1.0 \text{ ok}$$



There's always a solution in steel!

Final Column Sizes

- Exterior Columns: W30x99
 - Braced by struts aligned with longitudinal bracing, $L_b = 20$ ft. max.
- Interior Columns: W24x146
 - Braced by crane beam / longitudinal crane bracing
- Crane Columns: W14x90 if only one tie provided at top of column; W14x61 if add intermediate tie or brace at mid-height to adjacent building column



There's always a solution in steel!

33

Design of an Industrial Crane Building

- **Lesson 6**
 - Final Design of the Building Columns
 - Final Design of the Truss
 - Design of the Frame Connections
 - Design of the Anchor Rods



There's always a solution in steel!

34

AISC Seismic Manual 2010

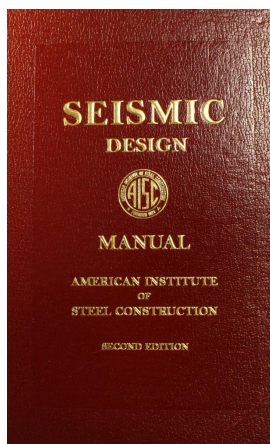

There's always a solution in steel!

2010 AISC Seismic Provisions E.1 Ordinary Moment Frames

Application of OMF Requirements (E.1 & Commentary):

- Minimal inelastic deformation capacity required, members and connections
- No limits on width to thickness ratios of members beyond the *Specification*.
- Truss and FR moment connection is designed for required flexural strength and required shear strength equal to the maximum moment and corresponding shear that can be transferred to the truss and the connection by the system including the effects of overstrength and strain hardening.



There's always a solution in steel!

36

2010 AISC Seismic Provisions E.1 Ordinary Moment Frames

Application of OMF Requirements (E.1 & Commentary):

The maximum force transferred by the system is determined based on flexural yielding (hinging) of the moment frame columns.



There's always a solution in steel!

37

Design of the OMF Truss

- Determine end moments and axial forces acting on the truss for the seismic load cases
- E based on $1.1R_yM_p$ of the columns LRFD
- $(1.1R_yM_p/1.5)$ for ASD)



There's always a solution in steel!

38

Design of the OMF Truss

Determine Chord forces acting on the end of the truss due to column yielding.

- W30x99 column at the left end of the truss

$$M_{\text{elleft}} = 1.1 * 1.1 * 50 * 312 / 1.5 = 12,584 \text{''-k}$$

$$P_{\text{elleft}} = 12584 \text{''-k} / (60 \text{''} - 3 \text{''}) = 221 \text{k}$$

- W24x146 column at the right end of the truss

$$M_{\text{eright}} = 1.1 * 1.1 * 50 * 418 / 1.5 / 2 = 8430 \text{''-k}$$

$$P_{\text{eright}} = 8430 \text{''-k} / (60 \text{''} - 3 \text{''}) = 148 \text{k}$$

Determine truss Gravity Loads for load case 5a

$$P_{\text{vert}} = (1 + 0.14 * .77) * (.013) * (5) * (30) = 2.1 \text{k}$$



There's always a solution in steel!

39

Design of the OMF Truss

Load Diagram Load Case 5a (ASCE 7-10 Section 12.2.2.3)

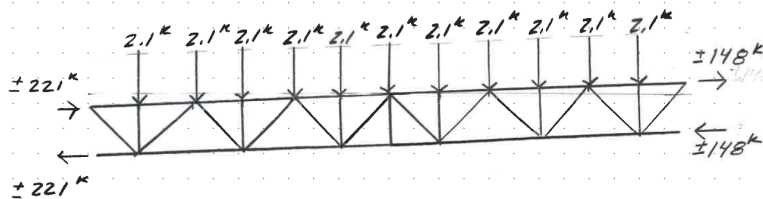

There's always a solution in steel!

40

Design of the OMF Truss

Model the truss with continuous chords and pinned diagonal members.

Based on analysis of the truss for the load diagram on the previous slide, the top chord forces at the critical location are:

- $P_{max} = 204.7k$
- $M_{max} = 62.5''-k$
- Check WT9x43.0 chord. Based on aligning braces with roof bracing use 10' unbraced length.
- Axial Strength use table 4-7



There's always a solution in steel!

Design of the OMF Truss

Table 4-7 (continued)
 Available Strength in Axial Compression, kips $F_y = 50 \text{ ksi}$
 WT-Shapes

Shape	WT9						WT10					
	4x3		4x4		5x7		5x9		6x9		6x12	
Design	P_n/Ω_c	$\phi_c P_n$	P_n/Ω_c	$\phi_c P_n$	P_n/Ω_c	$\phi_c P_n$	P_n/Ω_c	$\phi_c P_n$	P_n/Ω_c	$\phi_c P_n$	P_n/Ω_c	$\phi_c P_n$
0	435	539	356	534	274	412	299	450	250	376	219	315
10	362	444	306	450	239	366	262	393	223	339	187	281
12	337	407	286	430	226	339	246	370	209	314	178	267
14	310	380	264	397	210	316	226	345	196	291	168	250
16	282	404	241	363	194	292	212	319	182	273	157	235
18	255	380	218	337	177	266	193	291	167	251	145	219
20	224	358	194	309	160	240	175	262	152	229	133	200
22	195	334	171	287	143	215	156	234	137	209	121	182
24	165	310	148	263	126	190	138	207	122	184	109	164
26	144	276	128	239	109	166	120	181	108	162	97.3	146
28	124	246	110	216	95.3	143	104	150	94.1	141	85.9	128
30	108	212	95.8	184	83.1	125	90.6	136	81.9	123	75.1	113
32	94.9	183	84.2	157	73.0	110	79.6	120	72.0	108	66.0	99.0
34	84.0	158	74.5	137	64.7	97.2	70.2	106	63.8	95.9	58.5	87.9
36	75.9	113	66.5	100	57.7	86.7	62.9	94.3	56.9	85.5	52.2	78.4
40	60.7	87.2	53.0	81.0	46.7	70.2	50.0	70.6	46.3	69.3	42.6	63.3

$$P_n/\Omega = 287k$$

Table 4-7 considers torsional and flexural torsional buckling per Specification Section E4



There's always a solution in steel!

Design of the OMF Truss

- Calculate Flexural Strength per Section F9.
- Applicable limit states are yielding, Lateral torsional buckling, and local buckling.
- Yielding per F9.1(b) stem in compression

$$M_p = F_y Z_x \leq M_y \text{ where } M_y = F_y S_x$$

$$M_p = (50 \text{ ksi})(19.90 \text{ in}^3) \leq (50 \text{ ksi})(11.2 \text{ in}^3)$$

$$M_p = 560 \text{ in.} - \text{kip}$$



There's always a solution in steel!

43

Design of the OMF Truss

- Lateral Torsional Buckling per F9.2 with stem in compression

$$M_{cr} = \left(\frac{\pi \sqrt{EI_y GJ}}{L_b} \right) (B + \sqrt{1 + B^2})$$

$$\text{Where: } B = \pm 2.3(d/L_b) \sqrt{\frac{I_y}{J}}$$

- + B applies for stem in tension
- B applies for stem in comp.



There's always a solution in steel!

44

Design of the OMF Truss

- Lateral Torsional Buckling per F9.2 with stem in compression

$$B = -2.3 \left(\frac{9.2}{120} \right) \sqrt{\frac{87.6}{2.04}} = -1.15$$

$$M_{cr} = \left(\frac{3.14 \sqrt{(29000)(87.6)(11200)(2.04)}}{120} \right) (-1.15 + \sqrt{1 + (-1.15)^2})$$

$$M_{cr} = 2,347 \text{ in.} \cdot \text{kip} > M_p$$

Lateral torsional buckling does not control



There's always a solution in steel!

45

Design of the OMF Truss

- Local Buckling of the Tee stem F9.4 stem in compression

$$M_n = F_{cr} S_x \quad \text{when} \quad \frac{d}{t_w} \leq .84 \sqrt{\frac{E}{F_y}} \quad F_{cr} = F_y$$

$$\frac{d}{t_w} = 19.2 \leq .84 \sqrt{\frac{29000 \text{ ksi}}{50 \text{ ksi}}} = 20.2 \quad M_n = (50 \text{ ksi})(11.2 \text{ in}^3)$$

$$M_n = 560 \text{ in.} \cdot \text{kip} \quad M_n / \Omega = \frac{560 \text{ in.} \cdot \text{kip}}{1.67} = 335 \text{ in.} \cdot \text{kip}$$



There's always a solution in steel!

46

Design of the OMF Truss

- Check Combined Axial and Bending of the Tee stem

$$P_r = 204.7 \text{ kips} \quad P_n/\Omega = 287 \text{ kips}$$

$$M_r = 62.5 \text{ in-kip} \quad M_n/\Omega = 335 \text{ in-kip}$$

$$\frac{204.7}{287} + \frac{8}{9} \left(\frac{62.5}{335} \right) = .88 \leq 1.0 \text{ OK}$$



There's always a solution in steel!

47

Design of the OMF Truss

Verify the diagonal members:

Based on analysis:

$$\text{Max. } P_r = -60.2^k$$

Based on truss geometry:

$$L = 83'' = 6.9 \text{ ft.}$$

$$2L3 \frac{1}{2} \times 3 \frac{1}{2} \times 5/16$$

X axis controls

$$P_n/\Omega = 65.8^k$$

3 equally spaced connectors required.



There's always a solution in steel!

48

Table 4-8 (continued)
Available Strength in Axial Compression, kips
Double Angles—Equal Legs

Shape	2L3 1/2 x 3 1/2							
	5/8		5/8		5/8		5/8	
lb/ft	22.2	19.6	17.0	14.4	11.8	11.8	11.8	11.8
Design	P_n/Ω	ϕP_n	P_n/Ω	ϕP_n	P_n/Ω	ϕP_n	P_n/Ω	ϕP_n
0	146	211	125	187	104	162	90.5	136
1	139	209	124	186	107	161	90.0	135
2	130	205	121	182	105	158	89.2	133
3	127	198	117	176	102	153	86.4	128
4	126	189	112	168	98.9	146	81.6	121
5	118	177	105	158	91.3	137	77.0	116
6	109	164	97.7	147	84.6	128	71.7	108
7	106	160	95.6	145	82.9	126	70.6	106
8	90.2	136	80.9	122	70.6	109	58.7	88.8
9	86.3	131	77.3	116	67.0	104	55.5	84.4
10	70.4	106	63.5	96.4	55.6	83.6	47.3	71.0
11	61.0	91.6	55.1	82.8	48.4	72.7	41.2	62.0
12	51.9	78.1	47.1	70.8	41.5	62.4	35.6	53.4
13	44.3	66.5	40.1	60.3	35.4	53.1	30.3	45.5
14	38.2	57.4	34.6	52.0	30.5	45.8	26.1	39.2
15	33.2	50.0	30.1	45.3	26.6	39.9	22.7	34.2
16	29.2	43.9	26.5	39.6	23.3	35.1	20.0	30.0
17	25.9	38.9	23.2	35.3	20.7	31.1	17.7	26.6
18	23.0	35.9	21.2	32.3	19.1	28.1	15.8	23.7
19	20.4	32.4	19.1	29.1	17.5	25.1	14.2	21.1
20	18.1	29.1	17.5	26.1	16.0	22.1	12.8	18.1
21	16.1	26.1	16.0	23.1	14.6	19.1	11.6	16.1
22	14.4	23.1	14.6	20.1	13.3	16.1	10.5	14.4
23	12.9	20.1	13.3	17.1	12.1	13.1	9.5	12.9
24	11.6	17.1	12.1	14.1	11.0	10.1	8.6	11.6
25	10.5	14.1	11.0	11.1	10.0	9.1	7.8	10.5
26	9.5	11.1	10.0	8.1	9.1	8.1	7.1	9.5
27	8.6	8.1	9.1	5.1	8.1	7.1	6.1	8.6
28	7.8	5.1	8.1	2.1	7.1	6.1	5.1	7.8

Properties of 2 angles—1/2 in. back to back

A_g , in ²	6.50	5.78	5.00	4.30	3.60
I_x , in ⁴	1.05	1.07	1.08	1.09	1.09
I_y , in ⁴	1.63	1.61	1.59	1.59	1.57

Properties of single angle

I_x , in ⁴	0.679	0.681	0.683	0.685	0.688
-------------------------	-------	-------	-------	-------	-------

$\phi = 0.90$
 $\phi = 1.67$

Design of the OMF Truss

Design the typical truss connections:

Must check for limit states of:

- Weld shear rupture (dbl. angle to tee weld)
- Base metal shear rupture (dbl. angle to tee weld)
- Tensile rupture (dbl. angle)
- Whitmore yielding and buckling (tee web)
- Block shear strength (tee web)
- Vertical shear (tee)

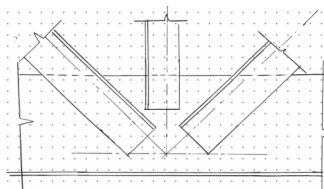

There's always a solution in steel!

49

OMF Truss Panel Connection

Connection Force : $P_{max} = 60.2k$

Weld Shear Rupture (Table J2.5)

$$\frac{R_n}{\Omega} = .6F_{exx} * t_{eff} / \Omega \quad \frac{R_n}{\Omega} = .6(70) .25 * \frac{.7071}{2} = 3.71 \text{ k/"}$$

Base Metal Shear Rupture – Tee (J4.2)

$$\frac{R_n}{\Omega} = .6F_u * A_{nw} / \Omega \quad \frac{R_n}{\Omega} = .6(65) \left(\frac{.48}{2}\right) / 2 = 4.68 \text{ k/"}$$

Base Metal Shear Rupture – Angle (J4.2)

$$\frac{R_n}{\Omega} = .6F_u * A_{nw} / \Omega \quad \frac{R_n}{\Omega} = .6(58) (.3125) / 2 = 5.44 \text{ k/"}$$

$L_{req} = 60.2 / 3.71 = 16.2$ " Use (4) 5" long 1/4 fillet welds



There's always a solution in steel!

50

OMF Truss Panel Connection

Connection Force: $P_r = 60.2$ kips (+/- Max T&C)

Double angle tensile rupture (d2(b))

$$\frac{R_n}{\Omega} = F_u A_n / \Omega \quad A_e = A_n U \quad U = 1 - x/L$$

$$U = 1 - \frac{.797}{5} = .804$$

$$\frac{R_n}{\Omega} = (58)(3.9)(.804)/2.00 = 90.9 \text{ kips} > 60.2 \text{ kips OK}$$



There's always a solution in steel!

51

OMF Truss Panel Connection

Connection Force : $P_{\max} = - 60.2^k$ (+/- Max T & C)

Whitmore Yielding (tension)

$$\frac{R_n}{\Omega} = F_y A_w / \Omega \quad A_w = W_{wh} t_w$$

$$W_{wh} = L_{angle} + 2L_{weld} \tan(30) = 3.5 + (2)(5) \tan(30)$$

$$W_{wh} = 9.27''$$

$$\frac{R_n}{\Omega} = (50)(9.27 * .48)/1.67 = 133^k > 60.2^k$$

Whitmore Buckling (Comp.)



There's always a solution in steel!

52

OMF Truss Panel Connection

Whitmore Buckling (Comp.)

$$r_{pl} = \sqrt{\frac{t^2}{12}} = \sqrt{\frac{.48^2}{12}} = .138''$$

$$Kl/r = 1.5 \cdot 4 / .138 = 43.5$$

$$\text{From table 4-22 } \frac{F_{cr}}{\Omega} = 26.1 \text{ ksi}$$

$$\frac{R_n}{\Omega} = (26.1 \text{ ksi})(9.27 \cdot .48) = 116.1 \text{ k} > 60.2 \text{ k} \quad \text{OK}$$



There's always a solution in steel!

53

OMF Truss Panel Connection

Connection Force: $P_r = 60.2 \text{ kips}$ (+/- Max T&C)

Block Shear Strength Section J4.3 Equation J4-5

$$\frac{R_n}{\Omega} = \frac{.6F_u A_{nv} + U_{bs} F_u A_{nt}}{2.00} \leq \frac{.6F_y A_{gv} + U_{bs} F_u A_{nt}}{2.00}$$

Welded connection, therefore $A_{nv} = A_{gv}$

$$\text{Conservatively } A_{gv} = (.48 \text{ in.})(2 \times 5 \text{ in.}) = 4.8 \text{ in}^2$$

$$A_{nt} = (.48 \text{ in.})(3.5 \text{ in.}) = 1.68 \text{ in}^2$$

$$R_n/\Omega = (.6(50)(4.8) + (1.0)(65)(1.68))/2 = 126.6 \text{ kips} > 60.2 \text{ kips} \quad \text{OK}$$



There's always a solution in steel!

54

OMF Truss Panel Connection

Connection Force: $P_{\max} = -60.2^k$ (+/- Max T & C)

Chord Shear Strength Chapter G

$$V_n = .6F_y A_w C_v \quad \Omega = 1.67 \quad \text{Section G2}$$

When $h/t_w \leq 1.1\sqrt{kvE/F_y}$ $C_v = 1.0$

$$C_v = 1.51kvE / ((h/t_w)^2 F_y)$$

$$h/t_w = 19.2 < 1.1\sqrt{\frac{5(29000)}{50}} = 59.2 \quad C_v = 1.0$$

$$V_n = .6(50)(.48 * 9.2)1.0 = 132.5^k$$

$$\frac{R_n}{\Omega} = 132.5^k / 1.67 = 79.3^k > 60.2^k (57/83) = 41.3^k \text{ OK}$$



There's always a solution in steel!

55

OMF Truss Panel Connection

Check shear rupture per J4.2

$$R_n = .60F_u A_{nv} \quad \Omega = 2.00$$

$$R_n / \Omega = .60(65)(.48)(9.2) / 2.0 = 86.1 \text{ kips} > 41.3 \text{ kips ok}$$



There's always a solution in steel!

56

OMF Truss Panel Connection

TYPICAL TRUSS CONNECTION
BOTTOM CHORD

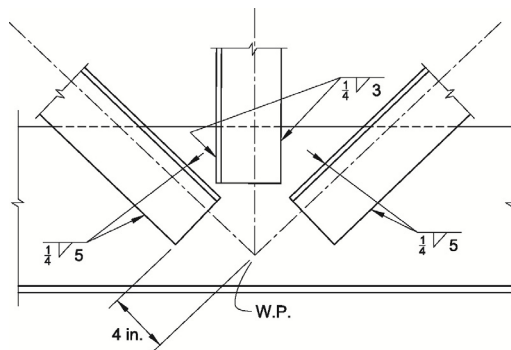

There's always a solution in steel!

57

Truss Chord Bracing

2 options:

1. Model the frame including the truss and the chord bracing system into a second order analysis.
2. Design the braces per Appendix 6 Stability Bracing for Columns and Beams

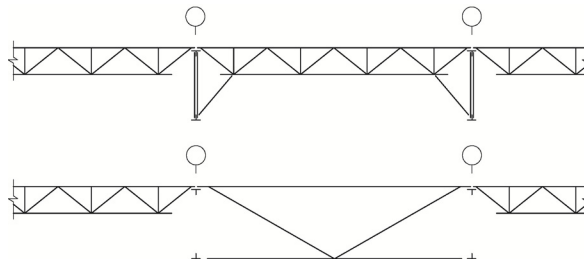

There's always a solution in steel!

58

Design of an Industrial Crane Building

• Lesson 6

- Final Design of the Building Columns
- Final Design of the Crane Columns
- Final Design of the Truss
- Design of the Frame Connections
- Design of the Anchor Rods



There's always a solution in steel!

59

2010 AISC Seismic Provisions Section A4

Section A4 of the Seismic Provisions requires the following information to be on the structural drawings (partial list):

- Designation of the *seismic load resisting system* (SFRS)
- Identification of the members and connections that are a part of the SFRS
- Configuration of the connections
- Connection material specifications and sizes
- Locations of *demand critical welds*
- ...



There's always a solution in steel!

60

Design of the OMF Connections

- The design of the OMF connections must meet the AISC 341 Seismic Provisions.
- For Joist Girders, the design procedures can be found in the SJI Technical Digest 11, "Design of Lateral Load Resisting Frames Using Steel Joists and Joist Girders", November 2007



There's always a solution in steel!

61

Exterior Moment Connection

This detail provides a direct transfer of the chord forces to the column.

Connection of the truss to the column must be based on developing $1.1R_yM_p$ of the column.

(Same as truss design)

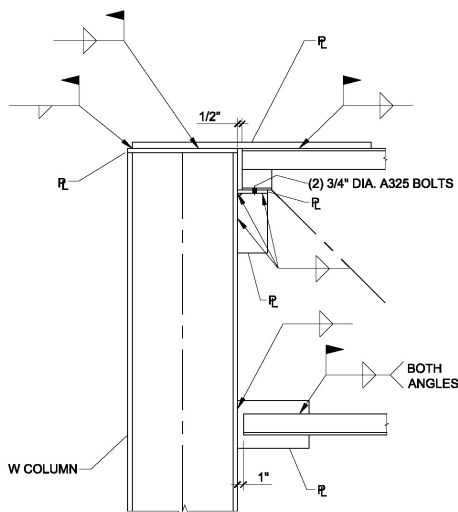

There's always a solution in steel!

62

Interior Moment Connection

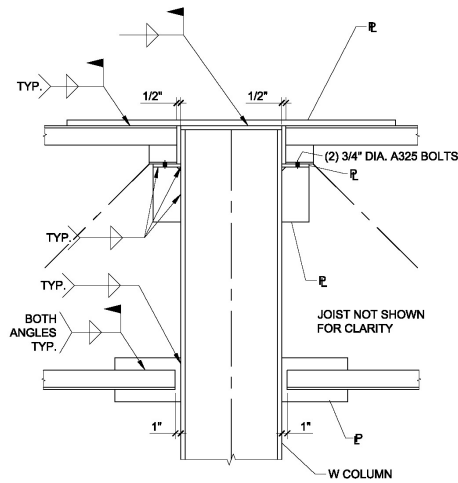

There's always a solution in steel!

63

OMF Connections

- The top plate and the bottom plate sizes are determined from the maximum chord force (based on $M=1.1R_yM_p$ of column).
- The seat size is determined using Table 10-8, "Bolted/Welded Stiffened Seated Connections" in the AISC Manual



There's always a solution in steel!

64

Truss Seat Connection

- Salmon and Johnson (1996) indicates four steps for the design of stiffened seats for beam reactions. These are:
 - Determine the seat width
 - Determine the eccentricity e_s of load
 - Determine the stiffener thickness t_s
 - Determine the angle or plate sizes and arrangement of bolts; or the weld size and length



There's always a solution in steel!

65

Truss Seat Connection

- The seat width for beam reactions is based on the required bearing for the beam to prevent local web yielding and web crippling. For the truss same limit states apply to the web of the tee. The vertical reaction is located at the work point of the end diagonal member.
- Based on the limit states of Web Local Yielding (J10.2) and Web Local Crippling (J10.3) a bearing length of 4" is selected.

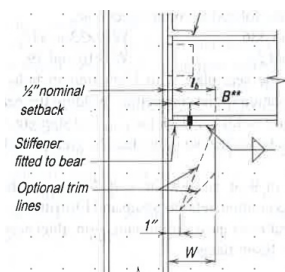

There's always a solution in steel!

66

Truss Seat Connection

The text by Salmon and Johnson indicates the following limit states for design of stiffened seats.

1. The stiffener thickness, t_s , should be equal to or greater than the thickness, t_w , of the supported beam web. Since the WT web is .48" use a $\frac{3}{4}$ " thick A36 plate.
2. Local buckling of the stiffener must be prevented. Local buckling is prevented provided the stiffener thickness is greater than or equal to $w/16$ per the 2010 AISC Specification Section J10.8(2). W = width of stiffener.
3. The design bearing strength, R_n , on the contact area of stiffener must satisfy the bearing equation from the 2010 AISC Specification Eqn. J7-1

$$(R_n = 1.8F_y A_{pb}, \Omega = 2.0, \phi = 0.75)$$



There's always a solution in steel!

67

Truss Seat Connection

- Limit States
 - Eccentric loading on the stiffener and weld
 - Stiffener shear yielding



There's always a solution in steel!

68

Truss Seat Connection

- Eccentric Loading on the stiffener (S&J)

$$t_s = \frac{P(6e_s - 2W)}{.90F_yW^2} = \frac{P(6 * 2.5 - 2 * 4.5)}{.90(36)4.5^2} = .0091P$$

For a 3/4" plate: $P_a = .75 / .0091 = 82.4 \text{ kips} > 43 \text{ kips}$ OK

Where, e_s = erection clearance + N/2 or $w - N/2$.

For A36 plate ($F_y = 36 \text{ ksi}$):

$w = 4 \text{ in.} + 0.5 \text{ in. (setback)} = 4.5 \text{ in}$

$e_s = 4.5 - 4/2 = 2.5 \text{ in.}$ $\Omega = 2.0$



There's always a solution in steel!

69

Truss Seat Connection

Stiffener shear yielding:

- $R_n = .6F_y * t_s * L = .6 * 36 * .75 * 12 = 194.4k$
- $R_n / \Omega = 116.4k > 43k$

Stiffener to Column Weld:

Refer to manual table 10-8

- For a 12" long seat 5" wide 5/16" weld;
- $R_n / \Omega = 80.2k$ $L = \text{stiffener length, 12 in.}$
 $\Omega = 1.67$



There's always a solution in steel!

70

Truss Seat Connection

**Table 10-8
 Bolted/Welded Stiffened
 Seated Connections
 Weld Available Strength, kips**

Width of Seat, *W*, in.

<i>L</i> , in.	70-ksi Weld Size, in.							
	4				5			
	1/4		5/16		3/8		7/16	
ASD	LRFD	ASD	LRFD	ASD	LRFD	ASD	LRFD	
6	22.7	34.9	29.4	42.5	34.0	51.1	33.7	50.8
7	29.9	44.9	37.4	56.1	44.9	67.3	43.6	63.2
8	37.8	56.7	47.2	70.8	56.7	85.0	56.2	80.8
9	46.1	69.2	57.7	86.5	69.2	101	69.1	97.1
10	54.9	82.3	68.6	103	82.3	120	82.3	112
11	63.9	95.8	79.8	120	95.8	141	108	134
12	73.1	110	91.4	137	110	166	130	160
13	82.5	124	103	155	124	190	144	187
14	92.1	138	115	173	138	217	161	217
15	102	152	127	191	152	249	183	257
16	111	167	139	209	167	280	195	280
17	121	181	151	227	181	312	218	307
18	131	196	163	245	196	343	240	330
19	140	211	175	263	211	376	263	354
20	150	225	188	281	225	408	285	384
21	160	240	200	300	240	449	309	419
22	169	254	212	318	254	491	331	445
23	179	269	224	336	269	533	353	470
24	189	283	236	354	283	575	375	495
25	198	297	248	372	297	617	397	520
26	208	312	260	390	312	660	419	545
27	217	326	272	408	326	702	441	570

Limitations for Connections to Column Webs

$\beta = 2\frac{1}{2}$ in. max	$\beta = 2\frac{1}{2}$ in. max
WT2-40, W14-43 for 2-5/16 in. limit weld = 5/16 in.	None

Notes:
 1. Values shown assume 70-ksi electrodes. For 60-ksi electrodes, multiply tabular values by 0.87, or enter table with 1.17 times the required strength.
 2. Tabular values are valid for stiffeners with minimum thickness of



There's always a solution in steel!

Truss to Column FR Conn,

- Design top plate for axial chord force:
- $$R_n = \frac{F_y A_g}{\Omega} = \frac{36(1.25 \cdot 9)}{1.67} = 242.5k > 221k$$
- Design Bottom plate:
- $$R_n = \frac{F_y A_g}{\Omega} = \frac{36(1.0 \cdot 12)}{1.67} = 258.7k > 221k$$
- Design the longitudinal fillet welds to the chord:
- Use 5/16 fillets $\frac{R_n}{\Omega} = 4.64 \text{ k/in}$ $L_{requ.} = 221/4.64 = 47.6"$
- Use (2) 24" lines of 5/16 fillet welds



There's always a solution in steel!



Truss Connection

- Design the transverse fillet welds from the bottom plate to the column flange:
- See J4, Linear welded group, uniform leg size, loaded through the center of gravity.

$$R_n = F_{nw}A_{we} \quad F_{nw} = .60F_{EXX}(1.0 + .50\sin^{1.5}\theta)$$

For 1/2" fillet welds the capacity per inch:

$$r_n/\Omega = .60 * 70(1.0 + .50\sin^{1.5}90)(.5*.7071)/2.00 = 11.1 \text{ k/"}$$

For 20" of weld:

$$\frac{r_n}{\Omega} = 222k > 221k \text{ ok}$$



There's always a solution in steel!

73

Truss Connection

- Check Column for Stiffeners:
- Flange Local Bending per J10.1: $\frac{R_n}{\Omega} = 84k < 221k \text{ ng}$
- Web Local Yielding per J10.2: $\frac{R_n}{\Omega} = 149.1k < 221k \text{ ng}$
- Web Local Crippling per J10.3: $\frac{R_n}{\Omega} = 84k < 221k \text{ ng}$
- Web Comp. Buckling per J10.5 : $\frac{R_n}{\Omega} = 90k < 221k \text{ ng}$

Stiffeners are required. See J10.8

- Size flange welds for diff. between required strength and available strength.
- Size web weld transfer stiffener force to the column web.



There's always a solution in steel!

74

Truss Connection

Check Column for Web Panel Zone Shear J10.6 (a)
 Panel zone deformation not considered in the analysis:

$$P_r \leq 4P_c \quad R_n = .60F_y d_c t_w \quad \Omega = 1.67$$

$$R_n / \Omega = .6(50)(.52)(29.7) / 1.67 = 277 \text{ kips} > 221 \text{ kips OK}$$

Note: The 221 kip demand is used for convenience and is conservative, The panel zone shear demand is actually based on the building code load combinations and does not need to achieve $1.1R_y M_p$



There's always a solution in steel!

75

Final Detail at Sidewalls

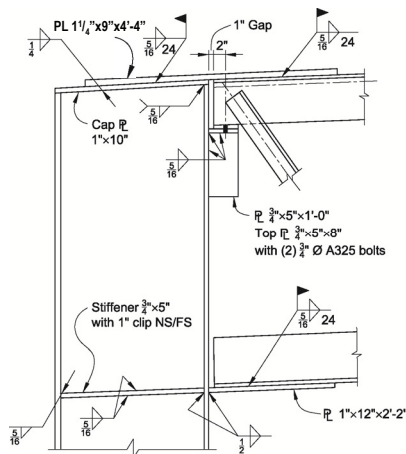

- Additional Design Steps:
1. Provide bearing for joists
 2. Review and coordinate with longitudinal bracing



There's always a solution in steel!

76

Alternate Joist Girders

As an alternate to the fabricated truss illustrated in this example a joist girder could be specified to act as the truss in the OMF.

SJI has Excel programs available from their website that can be used for the design of the JG to column connection.



There's always a solution in steel!

77

Controlling IBC Load Combinations (ASD)

Mark: G2 (Note: Left end @ sidewall)	Girder Designation: 60G12NSP			→ ←		
LRFD Load Combination:	Panel Load (kips)	Left End Moment (kip-ft.)	Right End Moment (kip-ft.)	TC Force (kips)	BC Force (kips)	Remarks
D + S	5.0	73	-487	2		
D + 3/4S + 1/4(Crane Lateral)	4.2	-43 120	-359 -515	3		
$(1.0 + 0.14S_{DS})D + M_{pe}/1.5$	2.2	+/-753	-/+703	4		
$[1.0 + (3/4)0.14S_{DS}]D + 3/4(M_{pe}/1.5) + 3/4S$	4.4	+/-565	-/+527	3		
$(0.6 - 0.14S_{DS})D + M_{pe}$	0.9	+/-753	-/+703	4		

M_{pe} in the load combination indicates the AISC OMF requirement, and the SJI requirement of applying $1.1R_yM_p$ to JG ends.



There's always a solution in steel!

78

Controlling IBC Load Combinations (ASD)

LRFD Load Combination:	Girder Designation: 60G12NSP					Remarks
	Panel Load (kips)	Left End Moment (kip-ft.)	Right End Moment (kip-ft.)	TC Force (kips)	BC Force (kips)	
D + S	5.0	487	-73	2		
D + 3/4S + 1/4(Crane Lateral)	4.2	359 515	43 -120	3		
$(1.0 + 0.14S_{DS})D + M_{pe}/1.5$	2.2	+/-703	-/+753	4		
$[1.0 + (3/4)0.14S_{DS}]D + 3/4(M_{pe}/1.5) + 3/4S$	4.4	+/-527	-/+565	3		
$(0.6 - 0.14S_{DS})D + M_{pe}$	0.9	+/-703	-/+753	4		

M_{pe} in the load combination indicates the AISC OMF requirement, and the SJI requirement of applying $1.1R_yM_p$ to JG ends.



There's always a solution in steel!

Design of an Industrial Crane Building

• Lesson 6

- Final Design of the Building Columns
- Final Design of the Crane Columns
- Final Design of the Truss
- Design of the Frame Connections
- Design of the Anchor Rods



There's always a solution in steel!

Anchor Rod Design



There's always a solution in steel!

81

Anchor Rod Design

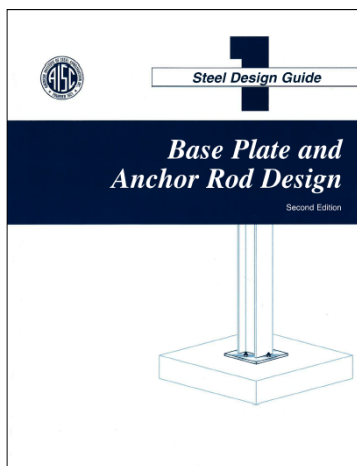

There's always a solution in steel!

82

Anchor Rod Specifications

ASTM F1554.

Two items of particular interest in 1554 relate to:

- Classification, and
- Product Marking (color coating)



There's always a solution in steel!

83

ASTM 1554 - Classifications

• Anchor rods furnished to the ASTM 1554 Specification can be obtained in three grades which denote three steel yield strengths, they are to be color coated as shown:

- **36 ksi - Blue**
- **55 ksi - Yellow ***
- **105 ksi - Red**

The 36 ksi rods, and the 55 ksi rods, can be obtained in diameters up to 4 in. The 105 ksi rods can be obtained up to 3 in. diameters.



*Supplement S1 for weldable material.
There's always a solution in steel!

84

Anchor Rod Erection Requirements Per OSHA 1926.75

- Minimum of 4 anchor rods
- Designed for a minimum load of 300 lbs at 18-inches eccentric from any column face
- Anchor rods shall not be repaired or replaced or field modified without the approval of SEOR
- Approval must state if repair/modification shall require guying or bracing of the column
- Contractor shall provide written notification to erector of any repair or modification



There's always a solution in steel!

85

Hole Sizes

AISC Anchor Rod Hole Sizes:

The recommended anchor rod hole diameters and minimum washer diameters and thicknesses can be found on page 14-21 of the AISC 14th edition Steel Construction Manual. The sizes are shown below:

Anchor Rod Diameter, in.	Hole Diameter, In.	Min. Washer Diameter, in.
3/4	1- 5/16	1- 7/8
7/8	1- 9/16	2- 1/4
1	1- 13/16	2- 5/8
1- 1/4	2- 1/16	2- 7/8
1- 1/2	2- 5/16	3- 1/8
1- 3/4	2- 3/4	3- 3/4
2	3-1/4	4- 1/2
2- 1/2	3-3/4	5



There's always a solution in steel!

86

Anchor Rod Available Strength, kips

Table 3.1. ASTM F1554 Anchor Rod (rod only) Available Tensile Strength, kips

Rod Diameter, in.	Rod Area, A_n , in. ²	LRFD $\phi = 0.75$			ASD $\Omega = 2.00$		
		ϕP_n			P_n/Ω		
		Grade 36 kips	Grade 55 kips	Grade 105 kips	Grade 36 kips	Grade 55 kips	Grade 105 kips
5/8	0.307	10.0	12.9	21.6	6.68	8.63	14.4
3/4	0.442	14.4	18.6	31.1	9.60	12.4	20.7
7/8	0.601	19.6	25.4	42.3	13.1	16.9	28.2
1	0.785	25.6	33.1	55.2	17.1	22.1	36.8
1 1/8	0.994	32.4	41.9	69.9	21.6	28.0	46.6
1 1/4	1.23	40.0	51.8	86.3	26.7	34.5	57.5
1 1/2	1.77	57.7	74.6	124	38.4	49.7	82.8
1 3/4	2.41	78.5	102	169	52.3	67.6	113
2	3.14	103	133	221	68.3	88.4	147
2 1/4	3.98	130	168	280	86.5	112	186
2 1/2	4.91	160	207	345	107	138	230
2 3/4	5.94	194	251	418	129	167	278
3	7.07	231	298	497	154	199	331
3 1/4	8.30	271	350	583	180	233	389
3 1/2	9.62	314	406	677	209	271	451
3 3/4	11.0	360	466	777	240	311	518
4	12.6	410	530	884	273	353	589



There's always a solution in steel!

87

Design of Anchor Rods in Tension:

- Determine the anchor rod tension.
- Select the anchor rod material and the number of anchor rods.
- Determine the base plate size and weld size.
- *Determine the required development length for the anchor rods.*



There's always a solution in steel!

88

AISC 341 REQUIREMENTS

AISC 341 Seismic Provisions, D2.6 Column **Bases**

- D2.6a Required **Axial** Strength – the greater of
 - (a)...calculated using the load combinations...including the amplified seismic load
 - (b)...required axial strength for column splices (D2.5b)
 - (a) ...*load combinations*...including the *amplified seismic load* or
 - (b) maximum force that can be delivered by the system



There's always a solution in steel!

89

AISC 341 REQUIREMENTS

AISC 341 Seismic Provisions, D2.6 Column **Bases**

- D2.6b Required **Shear** Strength
 - For Columns...required shear strength for column splices(D2.5c) which requires the greater of
 - (a) M_{pc}/h (LRFD) or $M_{pc}/(1.5h)$ (ASD)
 - (b) AISC 360 requirements and ...calculated using the *load combinations*...including the *amplified seismic load*



There's always a solution in steel!

90

AISC 341 REQUIREMENTS

AISC 341 Seismic Provisions, D2.6 Column **Bases**

- D2.6c Required **Flexural** Strength For Columns the lesser of
 - (a) $1.1R_yF_yZ$ (LRFD) $(1.1/1.5)R_yF_yZ$ (ASD)
 - or
 - (b) ...moment calculated using the load combinations...including the amplified seismic load



There's always a solution in steel!

91

AISC 341 REQUIREMENTS

AISC 341 Seismic Provisions, D2.6 Column **Bases**

Based on these rules, we calculate (for the critical load combination):

- | | |
|---------------------------|------------------------------|
| $P_r = 48 \text{ k}$ | (Ω load combination) |
| $M_r = 1006 \text{ k-ft}$ | (Ω load combination) |
| $V_r = 49 \text{ k}$ | (column flexure) |



There's always a solution in steel!

92

Large Moment Base Plate Design

Refer to AISC Design Guide 1
 Base Plate and Anchor Rod Design
 Second Edition

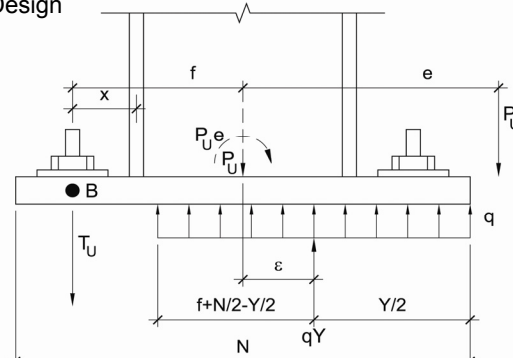

Fig. 3.4.1 Base Plate with Large Moment



There's always a solution in steel!

93

Anchor Rod Tension

For the W24x146: Using amplified forces for axial and the shear force based on hinging the column

$$P_r = 48.0 \text{ kips}, \quad M_r = 1006 \text{ kip-ft}, \quad V_r = 49 \text{ kips}$$

Try a base plate where $N = 40 \text{ in.}$ and $B = 24 \text{ in.}$

$$f'_c = 4 \text{ ksi}, \quad F_y \text{ of the base plate} = 36 \text{ ksi}, \quad \Omega_c = 2.31 \quad (\text{J8})$$

$$e = M_r / P_r = (1006 \text{ kip-ft})(12) / 48 \text{ kips} = \mathbf{251.5 \text{ in.}}$$

$$f_p(\text{max}) = \frac{.85 f'_c}{\Omega_c} \sqrt{\frac{A_2}{A_1}} \leq 1.7 f'_c = \frac{.85(4 \text{ ksi})}{2.31} (2) = 2.94 \text{ ksi}$$

$$q_{\text{max}} = (2.94 \text{ ksi})(B) = (2.94)(24 \text{ in.}) = 70.65 \text{ kips/in.}$$



There's always a solution in steel!

94

Anchor Rod Tension

Determine from Design Guide 1 equations if the base plate is considered a large moment base plate. If:

$$e > e_{crit} = \frac{N}{2} - \frac{P_a}{2q_{max}} = \frac{40 \text{ in.}}{2} - \frac{48 \text{ k}}{2(70.65 \text{ k/in}^2)} = 19.66 \text{ in.}$$

$e > e_{crit}$ 251.5 in. > 19.66 in.: Large moment base plate.

where:

e = the eccentricity of load, in.

N = the base plate length, in.

P_r = the required axial force in the column, kips

q_{max} = the maximum stress on the concrete



There's always a solution in steel!

95

Anchor Rod Tension

Check the inequality:

$$\frac{2P_a(e + f)}{q_{max}} < \left(f + \frac{N}{2}\right)^2 \text{ or a larger base plate is required}$$

$$\frac{2(48)(251.5 + 16)}{70.65} = 363.5 < \left(16 + \frac{40}{2}\right)^2 = 1296$$

OK, Base Plate Size is adequate to proceed.



There's always a solution in steel!

96

Base Plate Thickness

Washer size for 2-1/2 in. rod = 5 1/2 in. x 7/8 in.

Hole size = 3 3/4 in.

Check plate length beyond flange:

Washer/2 + edge distance + tolerance:

2.75 in. + 0.5 in. + 0.5 = 3.75 in.

Min. Plate length $\approx (2)16 \text{ in.} + (2)(3.75 \text{ in.}) = 39.5 \text{ in.}$

base plate 40 in. x 24 in. OK!

Based on current configuration
 Clearance for bolts

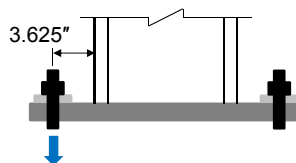

There's always a solution in steel!

99

Base Plate Thickness

Lever arm to flange = 3.625 in.

$M_t = (338 \text{ kips})(3.625 \text{ in.}) = 1225 \text{ kip-in.}$

$M_c = (5.46'')(70.65 \text{ k/}') (7.625 - 5.46/2) = 1888''\text{-k}$

Plate plastic modulus, $Z = Bt^2/4 = 24t^2/4 = 6t^2$

Plate strength $= \frac{F_y Z}{\Omega} = \frac{(36)(6t^2)}{1.67} = 129.34t^2$

$t = \sqrt{\frac{1888}{129.34}} = 3.82''$ Use 4" thick base pl.

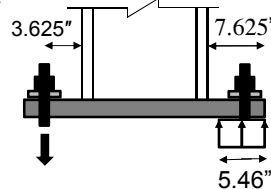

There's always a solution in steel!

100

Anchor Rods- Shear

- See AISC Design Guide 1 for suggestions and design procedures to transfer the shear load.
 - Bearing
 - Shear Lugs
 - Shear in Anchor Rods.



There's always a solution in steel!

101

Anchor Rod Development

- Refer to ACI 318- 14.

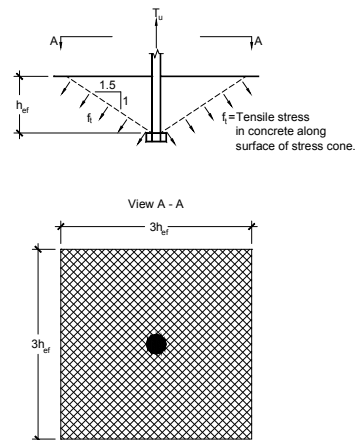

There's always a solution in steel!

102

End of Lesson 6



There's always a solution in steel!

103

Individual Webinar Registrants

PDH Certificates
Within 2 business days...

- You will receive an email on how to report attendance from: registration@aisc.org.
- Be on the lookout: Check your spam filter! Check your junk folder!
- Completely fill out online form. Don't forget to check the boxes next to each attendee's name!



There's always a solution in steel!

Individual Webinar Registrants

PDH Certificates
Within 2 business days...

- New reporting site (URL will be provided in the forthcoming email).
- Username: Same as AISC website username.
- Password: Same as AISC website password.



There's always a solution in steel!

8-Session Registrants

PDH Certificates
One certificate will be issued at the conclusion of
all 8 sessions.



There's always a solution in steel!

8-Session Registrants

QUIZZES

Access to the quiz: Information for accessing the quiz will be emailed to you by Wednesday. It will contain a link to access the quiz. EMAIL COMES FROM NIGHTSCHOOL@AISC.ORG

Quiz and Attendance records: Posted Tuesday mornings. www.aisc.org/nightschool - scroll down to Quiz and Attendance Records.

Reasons for quiz:

EEU – must take all quizzes and final to receive EEU

PDHS – If you watch a recorded session you must take quiz for PDHs.

REINFORCEMENT – Reinforce what you learned tonight. Get more out of the course.

NOTE: If you attend the live presentation, you do not have to take the quizzes to receive PDHs.



There's always a solution in steel!

8-Session Registrants

RECORDINGS

Access to the recording: Information for accessing the recording will be emailed to you by this Wednesday. The recording will be available for two weeks. For 8-session registrants only. EMAIL COMES FROM NIGHTSCHOOL@AISC.ORG.

PDHS – If you watch a recorded session you must take AND PASS the quiz for PDHs.



There's always a solution in steel!

Night School Resources for 8-session package Registrants

Find all your handouts, quizzes and quiz scores, recording access, and attendance information all in one place!



There's always a solution in steel!

Night School Resources for 8-session package Registrants

Go to www.aisc.org and sign in.



Login

If you're an existing customer, please enter your username and password.

USERNAME

Enter your username

PASSWORD

Enter your password

Remember Me

DON'T HAVE AN ACCOUNT?

My AISC allows you to access Engineering Journal articles and Design Guides you have downloaded from the bookstore.

[REGISTER NOW](#)



Night School Resources for 8-session package Registrants

IN THIS SECTION

- Edit Profile
- My Downloads
- My Pending Quizzes
- My Events
- Order History
- Course History
- Night School Resources**

MyAISC

MY PROFILE

Update your contact and address information.

[EDIT PROFILE](#)

MY PURCHASED DOWNLOADS

Access articles and documents that you have purchased.

MY ORDER HISTORY

View your past orders.

[VIEW ORDERS](#)



MY NIGHT SCHOOL RESOURCES

View online resources for Night School courses, available for 8-Session Package registrants. See www.aisc.org/nightschool for information on Night School including registration.

[VIEW RESOURCES](#)

Night School Resources for 8-session package Registrants

EDUCATION PUBLICATIONS NASCC: THE STEEL CONFERENCE SAFETY STEEL SOLUTIONS CENTER AWARDS AND COMPETITIONS



AISC

AISC > MYAISC > NIGHT SCHOOL RESOURCES

Night School Resources

Event	Date
NS 13 8-Session Package	1/30/2017 7:00:00 PM



There's always a solution in steel!

Night School Resources for 8-session package Registrants



Night School 13: Design of Industrial Buildings

8-SESSION PACKAGE RESOURCES

Event	Date	Handouts	Video	Quiz	Attendance
NS13 - Design Criteria	1/30/2017 7:00:00 PM	Handouts	Video Passcode: NS13DSN	Pass Score: 80	Pending
NS13 - Economic Considerations	2/6/2017 7:00:00 PM	Handouts	Available 02/08/2017 5pm EST	Available 02/08/2017 5pm EST	Pending
NS13 - Lateral Load Systems and Details	2/13/2017 7:00:00 PM	Handouts	Available 02/15/2017 5pm EST	Available 02/15/2017 5pm EST	Pending
NS13 - Preliminary Design Procedures	2/27/2017 7:00:00 PM	Handouts	Available 03/01/2017 5pm EST	Available 03/01/2017 5pm EST	Pending
NS13 - Crane Girder Design and Frame Analysis	3/6/2017 7:00:00 PM	Handouts	Available 03/08/2017 5pm EST	Available 03/08/2017 5pm EST	Pending
NS13 - Frame Member and Connection Design	3/13/2017 7:00:00 PM	Handouts	Available 03/15/2017 5pm EST	Available 03/15/2017 5pm EST	Pending
NS13 - Transfer Crane Girder & Longitudinal Bldg Bracing Dsn	3/27/2017 7:00:00 PM	Handouts	Available 03/29/2017 5pm EST	Available 03/29/2017 5pm EST	Pending
NS13 - Building Envelope and Bracing Design	4/3/2017 7:00:00 PM	Handouts	Available 04/05/2017 5pm EST	Available 04/05/2017 5pm EST	Pending
NS13 - Final Exam	4/10/2017 7:00:00 PM			Available 04/12/2017 5pm EST	

Night School Resources for 8-session package Registrants

- Weekly “quiz and recording” email.
- Weekly updates of the master Quiz and Attendance record found at www.aisc.org/nightschool. Scroll down to Quiz and Attendance records.
 - Updated on Tuesday mornings.



There's always a solution in steel!



Night School Resources for 8-session package Registrants

- Webinar connection information:
 - Found in your registration confirmation/receipt.
 - Reminder email sent out Monday mornings.
- Link to handouts also found here.



There's always a solution in steel!

Thank You

Please give us your feedback!
Survey at conclusion of webinar.

There's always a solution in steel.

