



AISC  
Night School

Thank you for joining our live webinar today.  
We will begin shortly. Please standby.

Thank you.  
Need Help?  
Call ReadyTalk Support: 800.843.9166



AISC  
Night School

Today's audio will be broadcast through the internet.

Alternatively, to hear the audio through the phone, dial 888 224 7958.



There's always a solution in steel!



AISC  
Night School

Today's live webinar will begin shortly.  
Please standby.  
As a reminder, all lines have been muted. Please type any questions or comments through the Chat feature on the left portion of your screen.

Today's audio will be broadcast through the internet.  
Alternatively, to hear the audio through the phone, dial 888 224 7958.



There's always a solution in steel!



AISC  
Night School

AISC is a Registered Provider with The American Institute of Architects Continuing Education Systems (AIA/CES). Credit(s) earned on completion of this program will be reported to AIA/CES for AIA members. Certificates of Completion for both AIA members and non-AIA members are available upon request.

This program is registered with AIA/CES for continuing professional education. As such, it does not include content that may be deemed or construed to be an approval or endorsement by the AIA of any material of construction or any method or manner of handling, using, distributing, or dealing in any material or product.

Questions related to specific materials, methods, and services will be addressed at the conclusion of this presentation.



There's always a solution in steel!





### Copyright Materials

This presentation is protected by US and International Copyright laws. Reproduction, distribution, display and use of the presentation without written permission of AISC is prohibited.

© The American Institute of Steel Construction 2017

The information presented herein is based on recognized engineering principles and is for general information only. While it is believed to be accurate, this information should not be applied to any specific application without competent professional examination and verification by a licensed professional engineer. Anyone making use of this information assumes all liability arising from such use.



### Course Description

#### Session 8: Building Envelope and Bracing Design April 3, 2017

Lesson 8 is the final lesson and the final design of the 50-ton overhead crane building design example is presented. The final roof and wall design is presented with a discussion relative to the design of standing seam roofs and to membrane roofs. Advantages and disadvantages of standing seam roofs are presented. Design concerns for metal roof deck and open web joists relative to mechanical membrane roofs subjected to wind uplift forces are presented. Proper specifications for open web joists subjected to gravity, uplift and roof ponding are discussed. Design procedures for cold-formed girts are presented along with wind column design. Lateral bracing calculations for the Ordinary Moment Frame (OMF) columns and beams are performed and discussed. The lesson concludes with suggested general notes for the installation of the runway beams.



### Learning Objectives

- Describe the advantages and disadvantages using a standing seam roof.
- List the key considerations to properly designing open web joists for roof structures.
- Describe the design procedure for rake beam design in an end wall.
- List the requirements for lateral bracing of an Ordinary Moment Frame (OMF).



#### Design of Industrial Buildings Session 8: Building Envelope and Bracing Design April 3, 2017



Presented by  
James M. Fisher, PE, PhD  
Emeritus Vice President  
Computerized Structural Design

There's always a solution in steel.



## AISC Night School 13

### Design of Industrial Buildings Lesson 8



Presenter:  
James Fisher



There's always a solution in steel!

9

## Design of an Industrial Crane Building

### Lesson 8

#### Roof Design

- Mechanically Fastened Membrane Roofs
- Standing Seam Roof Considerations
- Joist Design
  - Gravity loads, uplift loads, ponding

#### Wall Design

- Girt Design (Endwalls and Sidewalls)
- Rake Beam Design
- Wind Column Design

#### OMF Lateral Bracing Design



There's always a solution in steel!

10

## Review of Design Criteria

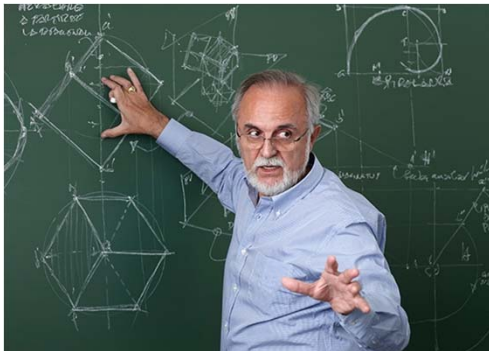

There's always a solution in steel!

11

## Project Description

- 50 ton, top running crane, Class D
- Quantity: 1 per aisle
- Hook height: 45 ft
- Roof type: Standing Seam on Joists
- Wall type: R- panel with continuous Zees
- Automatic Sprinkler System



There's always a solution in steel!

12

## Codes and Standards

- Building Code: IBC 2012
- Minimum Design Loads For Buildings And Other Structures (ASCE 7-10)
- Building Department Contact: John Smith
- Date: January 4, 2016
- Local Ordinances: None
- Wind Speed: 115 mph
- Wind Exposure: C
- Building Category II



There's always a solution in steel!

13

## Local Code Requirements

- Ground Snow Load: 15 psf
- Frost Depth: 24 in.



There's always a solution in steel!

14

## Loads

- ROOF DEAD LOAD
  - Roofing (SSR) 2.0 psf
  - Insulation 1.0 psf
  - Roof Bracing 1.0 psf
  - Joists 3.0 psf
  - Joist Girders 3.0 psf
  - Columns 6.0 psf
  - MEP Allowance 3.0 psf
  - **Total** **19.0 psf**
- WALL DEAD LOAD **3.0 psf**  
 (Includes Girts)



There's always a solution in steel!

15

## Loads

- ROOF LIVE LOADS
  - 20.0 psf (reduceable)
- SNOW LOADS
  - Ground Snow Load ( $P_g$ ): 15.0 psf
  - Importance Factor,  $I = 1.0$
  - Terrain Factor: C
  - Thermal Factor,  $C_t$ : 1.0
  - Exposure Factor,  $C_e$ , partially exposed: 1.0
  - Flat Roof Snow Load:  $P_f = 0.7(P_g)(I)(C_e) = 10.5 \text{ psf} < \text{Use } 20 \text{ psf}$
  - Building Category: II



There's always a solution in steel!

16



## Loads

### SEISMIC LOADS

- Spectral Acceleration,  $S_s$ : 1.054g
- Spectral Acceleration,  $S_1$ : 0.400g
- Occupancy Category: II
- Site Class: D
  - Soil shear wave velocity,  $\bar{V}_s$ : 800 ft/sec
  - Standard penetration resistance,  $\bar{N}$ : 15 blows
  - Soil undrained shear strength,  $\bar{\tau}_u$ : 1500 psf
- Importance Factor,  $I$ : 1.0
  
- Seismic Design Category: D



There's always a solution in steel!

17

## Loads

### WIND LOADS

- Occ. II Risk category, Table 1.5-1
- $V = 115$  Basic wind speed (3 second gust), mph, Fig. 26.5-1A
- $Exp = C$  Exposure category, Section 26.7
- $K_d = 0.85$  Wind directionality factor, Section 26.6 & Table 26.6-1
- $K_{zt} = 1$  Topographic factor, Section 26.6 & Fig. 26.8-1
- Encl. = Enclosure classification, Section 26.10
- $R = 1$  Large volume buildings reduction factor, Section 26.11.1.1
- $G = 0.85$  Gust factor, Section 26.9



There's always a solution in steel!

18

## Completed Design

- Final frame design
- Roof horizontal bracing
- Sidewall vertical bracing
- Endwall vertical bracing



There's always a solution in steel!

19

## Final Frame Design

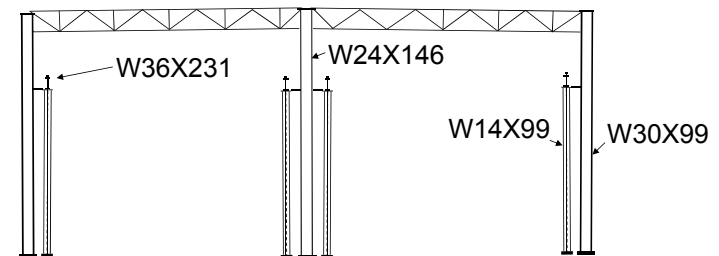

There's always a solution in steel!

20

## Roof Horizontal Bracing

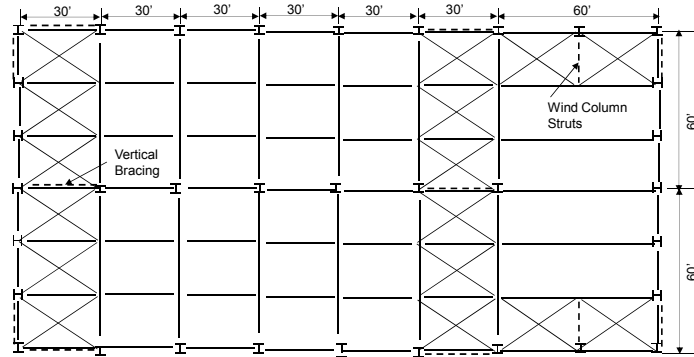

There's always a solution in steel!

21

## Sidewall Vertical Bracing

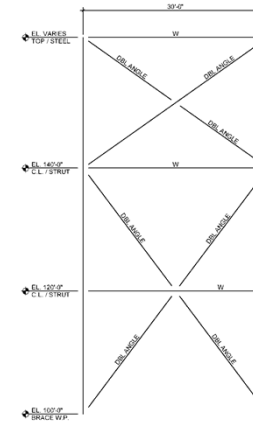

There's always a

22

## End Wall Vertical Bracing

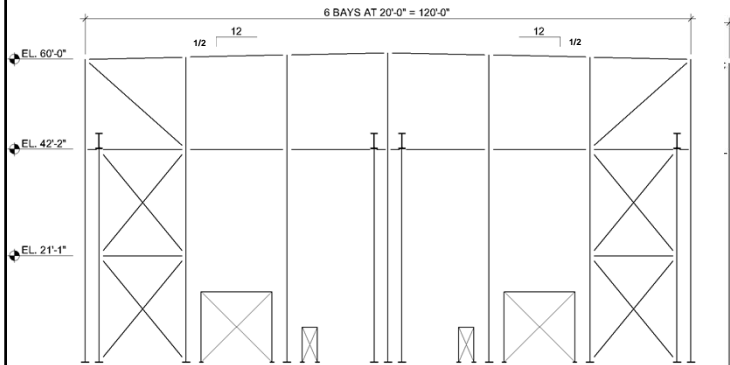

There's always a solution in steel!

23

## Roof Design

- Mechanically Fastened Membrane Roofs
- Standing Seam Roofs



There's always a solution in steel!

24



## Mechanically Fastened Membrane Roofs

---



There's always a solution in steel!

25

## Usage

---

- In the 1960s, single-ply membrane roof systems were first introduced into the U.S. roofing market and by the late 1970s, the **seam-fastened, mechanically-attached** method of installation was first introduced.
- With this installation method, the single-ply membrane sheet is **mechanically-attached along its outer edges** into the roof deck, which results in a larger tributary uplift load per fastener and fasteners being placed in linear, non-uniform loading configurations of the roof deck and underlying supporting structure



There's always a solution in steel!

26

## Usage

---

- When first introduced, membrane sheet widths in seam-fastened single-ply membrane roof systems typically were **five-foot-wide**, resulting in rows of mechanical fasteners in rows spaced at five feet on center.
- Since the early-2000s, single-ply membrane sheet widths have gotten wider, with **10-foot-wide sheets** now being commonplace -- resulting in rows of mechanical fasteners in rows spaced at 10 feet on center.
- In some cases, 12-foot wide sheets are being used and speculation is that **20-foot sheets** may be in the future.



There's always a solution in steel!

27

## Usage

---

- The seam-fastened, mechanically-attached method of installation has overtaken taken adhered methods of application used traditionally.



There's always a solution in steel!

28



## Deck and Joist Loading

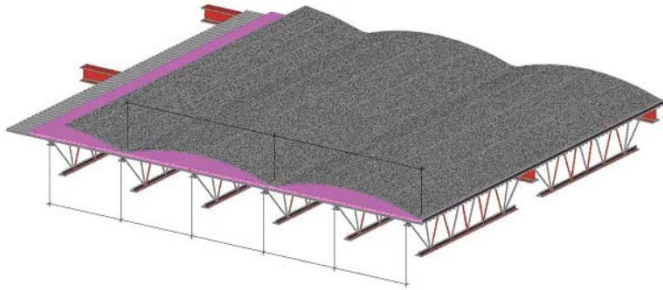

There's always a solution in steel!

29

## The Problem



From the National Research Council of Canada



There's always a solution in steel!

30

## Typical Layout

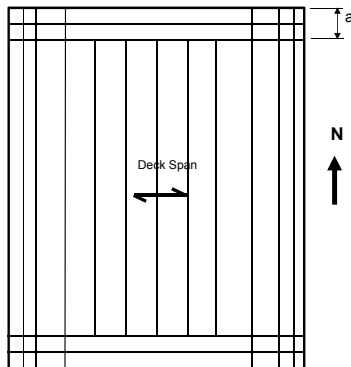

There's always a solution in steel!

31

## Fasteners Perpendicular to Deck Flutes

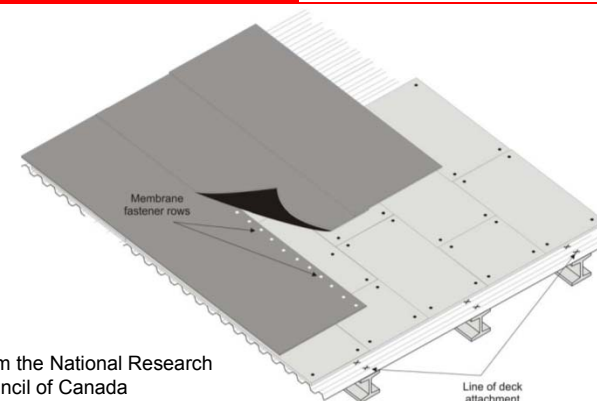

From the National Research Council of Canada



There's always a solution in steel!

32

## Fasteners Parallel to Deck Flutes

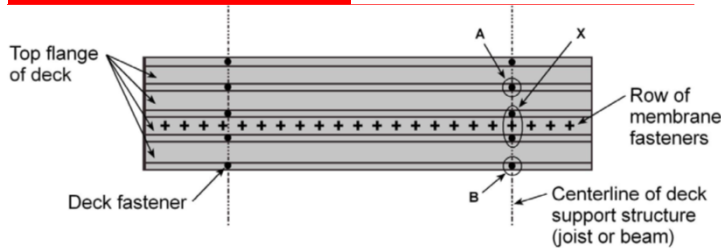

In this case, the 2 X deck fasteners must resist essentially 100% of the uplift load applied by the membrane fasteners because the steel deck transmits very little of the load to the adjacent deck fasteners A and B

From the National Research Council of Canada



There's always a solution in steel!

33

## Calculations for Deck Strength

Zone	Moment Line Load, $M_r$ (kip-inches)	$M_r / \phi M_p$ or $M_r / \phi M_n$	Moment Uniform Load, $M_r$ (kip-inches)	$M_r / \phi M_p$ or $M_r / \phi M_n$
Interior	4.85 <sup>1</sup>	0.95	1.24 <sup>2</sup>	0.23
East-West Perimeter	4.32 <sup>1</sup>	0.81	2.31 <sup>2</sup>	0.43
North-South Perimeter	11.9 <sup>2</sup>	<b>2.22</b>	2.22 <sup>2</sup>	0.41
Corner	11.55 <sup>2</sup>	<b>2.16</b>	3.48 <sup>2</sup>	0.65

1. Positive moment controls, 2. Negative moment controls  
 $\phi M_p = 5.088$  kip-in.,  $\phi M_n = 5.358$  kip-in.



There's always a solution in steel!

34

## Deck and Joist Design Case Study

- In order to comply with the IBC, the deck in the along the North-South Perimeter and the Corner Zones would have to be 16 gage.
- Joist Design:
  - Analysis indicates that the joists 6 ft. and 12 ft. from the building edges are not overloaded for the given geometry; however, the joists in the interior zone are significantly overloaded.
  - Design joists using ASD.
  - Joist Span = 33.3 ft., spacing = 6 ft.
  - Live Load = 20 psf, Dead Load = 6 psf



There's always a solution in steel!

35

## Joist Design Case Study

The unfactored uplift wind load = 33.3 psf  
 Uniform Net Uplift:  $0.6D + 0.6W = [(0.6)(6\text{psf}) - (0.6)(33.3\text{psf})](6\text{ft}) = 98$  plf  
 Concentrated Net Uplift:  $(0.6)(6\text{psf})(6\text{ft.}) - (0.6)(33.3\text{psf})(12\text{ft}) = 218$  plf

**Joist Weight (Normal Case):**  
 Uniform Case Gravity Load =  $(6\text{psf})(6\text{ft}) + (20\text{psf})(6\text{ft}) = 156$  plf  
 Use 18K156/120, Net Uplift = 98 plf  
**Weight/joist = 215 lbs**

**Joist Weight (12 ft Membrane Case):**  
 Concentrated Uplift Load Case: Net Uplift = 218 plf  
 Use 18K156/120, Net Uplift = 218 plf  
**Weight/joist = 260 lbs**  
**21% Increase.**



There's always a solution in steel!

36

## Paper in Structure Magazine – March 2017

---

### Are your roof members overstressed?

By: James M. Fisher, Ph.D., PE, Dist. M. ASCE , and  
Thomas Sputo, Ph.D., PE, SE, F.ASCE



There's always a solution in steel!

37

## Roof Design

---

- Standing Seam Roofs
  - Spans
  - Slope
  - Diaphragm
  - Anchorage
  - Snow drift areas



There's always a solution in steel!

38

## Standing Seam Roofs

---

- Spans: 5 ft
- Slope:  $\frac{1}{4}$  in./ft minimum
  - $\frac{1}{2}$  in./ft used
- Diaphragm: Limited
- Anchorage: One end
- Snow drift areas: Add secondary members



There's always a solution in steel!

39

## Standing Seam Roofs

---

- **Advantages**
  - The system is flexible and can accommodate the building movements associated with the overhead crane.
  - The roof can accommodate thermal movements without slotting the roofing at screw locations. This is particularly important when placing a metal roof on open web steel joists. Joist seats are stiff laterally, unlike cold-formed C or Z purlins, and do not roll as the roof attempts to expand and contract due to thermal loading.



There's always a solution in steel!

40

## Standing Seam Roofs

- **Disadvantages**

- First cost is greater than conventional roofs.
- Limited diaphragm strength and stiffness. Diaphragm strength cannot be relied upon to transfer horizontal roof forces to the vertical load resisting system. Other horizontal bracing systems must be used.



There's always a solution in steel!

41

## Roof Design Calculations

- Joists
- Girts
- Rake Beams
- Wind Columns



There's always a solution in steel!

42

## Joist Design

- Gravity Loads
- Ponding
- Seat Depths
- Wind Uplift

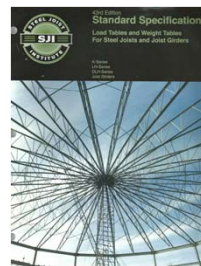

Free download from [steeljoist.org](http://steeljoist.org)



There's always a solution in steel!

43

## Joist Design- Gravity Loads

30 ft joists

Dead Load = 10 psf, Live Load = 20 psf,  $w = (10 \text{ psf} + 20 \text{ psf})(5 \text{ ft}) = 150 \text{ plf}$   
Try 18K3: 203 plf/123 plf

60 ft joists

Try 30K11: 231 plf/109 plf



There's always a solution in steel!

44

## Joist Calculations- Ponding

The structure is free draining to the eave; however, check to determine if the water can drain off the roof based on the deflection of the joists and Joist Girders. The eave is assumed not to deflect. Ignore joist and Joist Girder camber. Critical location is the first joist up from the eave.

30 ft joists (18K3) 203 plf/123 plf

$$I = 26.767(w_{LL})(L^3)(10^{-6}) \text{ in.}^4 \quad (\text{From SJI Catalog})$$

$$L = 30 \text{ ft} - 0.33 \text{ ft} = 29.67 \text{ ft}$$

$$I = (26.767)(123 \text{ plf})(29.67 \text{ ft})^3(10^{-6}) = 86 \text{ in.}^4$$

$$\Delta = \frac{(1.15)(5)w_{TL}L^4}{384EI} = \frac{(1.15)(5)(0.150)(29.67)^4(1728)}{(384)(29000)(86)} = 1.21 \text{ in.}$$

$$\text{Roof slope} = (0.50 \text{ in./ft})(5 \text{ ft}) = 2.50 \text{ in.}$$

1.21 in.  $\leq$  2.50 Positive slope exists o.k., not considering the Joist Girder deflection.



There's always a solution in steel!

45

## Joist Calculations- Ponding

- Determine the deflection of the Joist Girder 5 ft. upslope from the eave.
- The deflection at any point, x, along the Joist Girder can be determine using the following equation:

$$\Delta = \frac{wx}{24EI} (L_g^3 - 2L_g x^2 + x^3) \quad \text{From AISC Manual Table 3-23}$$

$$w = (10 \text{ psf} + 20 \text{ psf})(30 \text{ ft})/1000 = 0.90 \text{ kips/ft}, \quad x = 5 \text{ ft}, \quad L_g = 60 \text{ ft}$$

$$\text{From Lesson 4: } I_g = 13,167 \text{ in.}^4$$

$$\Delta = \frac{wx}{24EI} (L_g^3 - 2L_g x^2 + x^3)$$

$$= \frac{(0.90)(5)(1728)}{(24)(29000)(13,167)} [(60)^3 - 2(60)(5)^2 + (5)^3] = 0.18 \text{ in.}$$

$$\text{Total joist deflection} = 1.21 \text{ in.} + 0.18 \text{ in.} = 1.39 \text{ in.} < 2.50 \text{ in. o.k.}$$



There's always a solution in steel!

46

## Joist Calculations- Ponding

60 ft joists (30K11) 231 plf/109 plf

$$I = 26.767(w_{LL})(L^3)(10^{-6}) \text{ in.}^4$$

$$L = 60 \text{ ft} - 0.33 \text{ ft} = 59.67 \text{ ft}$$

$$I = (26.767)(109 \text{ plf})(59.67 \text{ ft})^3(10^{-6}) = 620 \text{ in.}^4$$

$$\Delta = \frac{(1.15)(5)w_{TL}L^4}{384EI} = \frac{(1.15)(5)(0.150)(59.67)^4(1728)}{(384)(29000)(620)} = 2.74 \text{ in.} > 2.50 \text{ in. n.g.}$$

$$\text{Joist Girder } \Delta, w = (30 \text{ psf})(45 \text{ ft}) / 1000 = 1.35 \text{ kips/ft}$$

$$\Delta = (0.18)(1.35/0.9) = 0.27 \text{ in.}$$

$$\text{Joist } I_{\text{req'd}} \text{ using } \Delta = 2.50 - 0.27 = 2.23 \text{ in.}, I_{\text{req'd}} = 760 \text{ in.}^4$$

$$\text{Solving for } w_{LL} = 134 \text{ plf}$$

$$\text{Use 32LH07, 271 plf / 140 plf, } I_{\text{furnished}} = 796 \text{ in.}^4$$



There's always a solution in steel!

47

## Roof Plan-Seat Depths

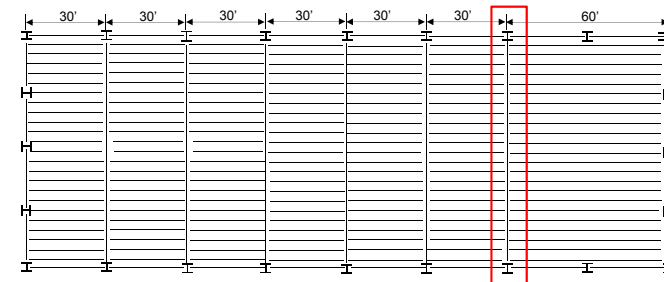

Typical 30 ft. joist: 18K3  
 Typical 60 ft. joist: 32LH07



There's always a solution in steel!

48

## Joist Wind Roof Suctions

Using Spreadsheet:

Part 1: Low-Rise Buildings  
 Gable Roof Pressures - Figure 30.4-2A ( h<60 feet & θ ≤ 7° )

Location	Tributary Area, ft. <sup>2</sup>							
	300		10		50		50	
	GCp	PSF	GCp	PSF	GCp	PSF	GCp	PSF
roof pressure - 1, 2, 3	0.20	12.4	0.30	15.7	0.23	13.4	0.23	13.4
roof suction - field - 1	-0.90	-35.3	-1.00	-38.6	-0.93	-36.3	-0.93	-36.3
roof suction - edge - 2	-1.10	-41.9	-1.80	-64.8	-1.31	-48.8	-1.31	-48.8
roof suction - corner - 3	-1.10	-41.9	-2.80	-97.5	-1.61	-58.6	-1.61	-58.6

Tributary area for joists = (1/3)(30)(30) = 300 ft<sup>2</sup>



There's always a solution in steel!

49

## Girder Roof Suctions

Using Spreadsheet:

Wind Loads For A Specific Height, h (Used for Components & Cladding)

Height	Kz	q	WW	LW	Total	Side	Roof WL		Int.	
			WL	WL	WL	WL	0 to h	h to 2h	> 2h	WL
0-15	0.85	24.43	16.6							
60	1.14	32.71	22.2	13.9	36.1	-19.5	-25.0	-13.9	-8.3	5.9



There's always a solution in steel!

50

## Joist Calculations

Uplift requirements (Gross)

Joists = (0.6)(35.3 psf) = 21.2 psf

Girders = (0.6)(25 psf + 5.9 psf) = 18.5 psf

Uplift requirements (Net)

Joists = 21.2 psf – (0.6)(7 psf) = 17.0 psf

Girders = 18.5 psf – (0.6)(10 psf) = 12.5 psf

ROOF DEAD LOADS

Roofing (SSR) 2.0 psf

Insulation 1.0 psf

Roof Bracing 1.0 psf

Joists 3.0 psf

Joist Girders 3.0 psf

Columns 6.0 psf

MEP Allowance 3.0 psf

Total 19.0 psf



There's always a solution in steel!

51

## Girt Design

- Cold-Formed Girts
  - Pressure and Suction
  - Maximum spans
  - Simple vs continuous span
  - Sag rods
  - OSHA requirements



There's always a solution in steel!

52



## Reference Material



1. Download all the AISI new standards from the link ([www.AISIStandards.org](http://www.AISIStandards.org))
2. Order the AISI Cold-Formed Steel Design Manual from the AISI online store or via the link (<https://shop.steel.org/p/312/cold-formed-steel-design-manual-2013-edition-electronic-version-includes-aisi-s1-12-specification-and-commentary>).



There's always a solution in steel!

53

## Girt Design- Sidewalls

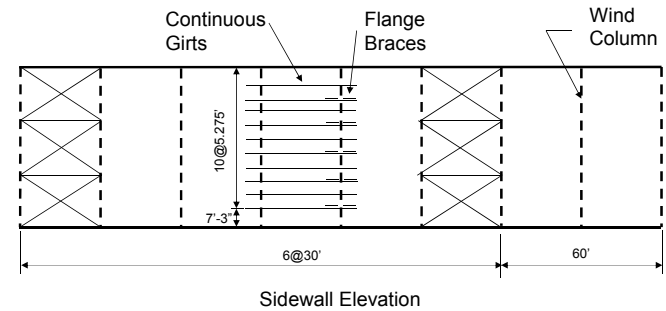

There's always a solution in steel!

54

## Girt Design- Endwalls

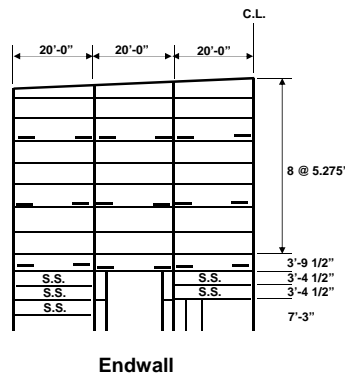

There's always a solution in steel!

55

## Girt Design

- Pressure and Suction Loads from IBC
- For pressure, the girts are laterally braced by the paneling.  $M_n = S_e F_y$   
 $\phi = 0.9, \Omega = 1.67$
- For suction, the strength of the girts is established using "R" values from the AISI Specification.  $M_n = R S_e F_y$   
 $\phi = 0.9, \Omega = 1.67$
- Sag rods are often used when the span exceeds 30 ft.



There's always a solution in steel!

56



## Girt Design- AISI Specification

TABLE D6.1.2.1  
 Single Span C- or Z- Section R Values

Depth Range, in. (mm)	Profile	R
$d \leq 6.5$ (165)	C or Z	0.70
$6.5$ (165) $< d \leq 8.5$ (216)	C or Z	0.65
$8.5$ (216) $< d \leq 11.5$ (292)	Z	0.50
$8.5$ (216) $< d \leq 11.5$ (292)	C	0.40



There's always a solution in steel!

57

## Girt Design- Windloads

Sidewall values:

- Tributary Area =  $[(5.275 \text{ ft} + 7.25 \text{ ft})/2](30 \text{ ft}) = 188 \text{ sq. ft}$
- Need not be  $< (1/3)(30)(30) = 300 \text{ sq.ft}$

Endwall values:

- Tributary Area (Typical girt) =  $(5.275)(20 \text{ ft}) = 106 \text{ sq. ft}$
- Need not be  $< (1/3)(20)(20) = 133 \text{ sq.ft}$

Conservatively use endwall values for all girts.



There's always a solution in steel!

58

## Girt Endwall Pressures

Using Spreadsheet:

SECONDARY FRAMING:  $p = qh^2[(GCp)-(GCpi)]$

qh = 32.71 psf	roof pitch	0.25	x/12
GCpi = 0.18 internal coefficient	roof slope	1.19	degrees
	reduction factor	0.9	

Wall Pressures - Figure 30.4-1 (h ≤ 60 feet)

Location	Tributary Area, ft <sup>2</sup>							
	133		10		10		10	
	GCp	P	GCp	P	GCp	P	GCp	P
wall pressure - 4 & 5	0.72	29.5	0.90	35.3				
wall suction - field - 4	-0.81	-32.4	-0.99	-38.3				
wall suction - edge - 5	-0.90	-35.4	-1.26	-47.1				



There's always a solution in steel!

59

## Girt Design

From AISI Specification D6.1.1:  $\Omega = 1.67$ ,  $R = 0.5$  for s.s. girt

Endwall:  $w = (5.275)(0.6)(35.4 \text{ psf}) = 112 \text{ plf} = 0.112 \text{ klf}$

$M = (1/8)wL^2 = (1/8)(0.112 \text{ plf})(20)^2 = 5.60 \text{ kip-ft}$

$$S_{req'd} = \frac{\Omega M}{RF_y} = \frac{(1.67)(5.6 \text{ kip-ft})(12 \text{ in./ft})}{(0.5)(50 \text{ ksi})} = 4.49 \text{ in.}^3 \text{ o.k.}$$

Specify: 10Z3.25x105  $S_x = 5.69 \text{ in.}^3$  (From AISI Manual)

Note: depth = 10 in., 3.25 flange width, 0.105 thickness



There's always a solution in steel!

60

## Design of Rake Beam

Seismic Loads Control:

$P_r$  (from analysis) = 24.6 kips

$M_r = (1/8)wL^2 = (1/8)[(1+0.14S_{DS})(0.15 \text{ klf}) + 0.30 \text{ klf}](20)^2 = 23.3 \text{ kip-ft}$

$S_{DS} = 0.770g$  (from Lesson 5)

$w_D = (10 \text{ psf})(30 \text{ ft} / 2)/1000 = 0.15 \text{ klf}$

$W_L = (20 \text{ psf})(30 \text{ ft} / 2)/1000 = 0.30 \text{ klf}$

$L = 20 \text{ ft}$

Try **W10x33**

From AISC Manual Table 6-1:  $p = 3.8 \times 10^3$ ,  $b_x = 9.18 \times 10^3$

Ratio =  $[(0.0038)(24.6) + (0.00918)(23.3)] = 0.31 < 1.0 \text{ o.k.}$

Use **W10x33** (seismically compact)



There's always a solution in steel!

61

## Wind Column Design

### MWFRS WIND LOAD CALCULATIONS

(ASCE 7-10)

Project: **ABC Building**  
 Job No.:  
 By: **JMF**  
 Date: **5/4/16**

$qz = 0.00256Kz^2Kd^2V^2$  (Eq. 27.3-1)

Occ. = **II** risk category, Table 1.5-1  
 $V = 115$  basic wind speed (3-second gust), mph, Figure 26.5-1A  
 Exp = **C** exposure category, Section 26.7  
 $K_d = 0.85$  wind directionality factor, Section 26.6 & Table 26.6-1  
 $K_z = 1$  topographic factor, Section 26.8 & Figure 26.8-1  
 Encl. = **E** enclosure classification, Section 26.10  
 $R_w = 1$  large volume buildings reduction factor, Section 26.11.1.1  
 $G = 0.85$  gust factor, Section 26.9  
 $z_0 = 900$  atmospheric boundary layer, ft., Table 26.9-1  
 $\alpha = 9.5$  3-sec gust speed power law exponent, Table 26.9-1

Pressure Coefficients per  
 Table 26.11-1 & 27.4-1

Height	$K_z$	$q_z$	Wind Pressures, psf							
			WW	LW	Total	Side	Roof WL		Internal	
			WL	WL	WL	WL	0 to h	h to 2h	> 2h	WL
0-15	0.85	24.43	16.6	10.4	27.0	-14.5	-18.7	-10.4	-6.2	4.4
20	0.90	25.95	17.6	11.0	28.7	-15.4	-19.9	-11.0	-6.6	4.7
30	0.98	28.27	19.2	12.0	31.2	-16.8	-21.6	-12.0	-7.2	5.1
40	1.04	30.03	20.4	12.8	33.2	-17.9	-23.0	-12.8	-7.7	5.4
50	1.09	31.48	21.4	13.4	34.8	-18.7	-24.1	-13.4	-8.0	5.7
60	1.14	32.71	22.2	13.9	36.1	-19.5	-25.0	-13.9	-8.3	5.9



There's always a solution in steel!

62

## Wind Columns

Sidewall Wind Columns:

Use  $p = (0.6)(22.2 \text{ psf} + 5.9 \text{ psf}) = 16.9 \text{ psf}$

Pressure:  $w = (16.9 \text{ psf})(30 \text{ ft})/1000 = 0.516 \text{ k/ft}$  (Use for suction also)

$M = (1/8)wL^2 = (1/8)(0.516 \text{ k/ft})(60 \text{ ft})^2 = 232 \text{ kip-ft}$  (Use Table 3-10)

Lateral bracing at  $\approx 10 \text{ ft}$  centers, Try **W18x55**,  $I_x = 890 \text{ in.}^4$

$$\Delta = \frac{5wL^4}{384EI} = \frac{(5)(0.516 \text{ k/ft})(60 \text{ ft})^4(1728)}{(384)(29000 \text{ ksi})(890 \text{ in.}^4)} = 5.83 \text{ in.}$$

Serviceability (10 year wind),  $H/120 = (60 \text{ ft})(12)/120 = 6.0 \text{ in.} > 5.83 \text{ in.}$

5.83 in. was for a 50 year wind.

Reaction at the top of column:  $(16.9 \text{ psf})(60 \text{ ft}/2)(30 \text{ ft})/1000 = 15.2 \text{ kips}$



There's always a solution in steel!

63

## Wind Columns

Endwall: Consider MWFRS

$p = (16.9 \text{ psf})(20) = 338 \text{ plf} = 0.338 \text{ klf}$

$M = (1/8)wL^2 = (1/8)(0.338 \text{ k/ft})(60 \text{ ft})^2 = 152 \text{ kip-ft}$  (Use ASIC Table 3-10)

Use a **W21x44**,  $I_x = 843 \text{ in.}^4$

Deflection ok by inspection



There's always a solution in steel!

64

## Bracing of Sidewall Columns

- AISC 2010 Specification Appendix 6  
 “Stability Bracing for Columns and Beams”
  - Beam columns
  - Nodal v. Relative Bracing
  - Beam Bracing
    - Nodal
    - Relative
    - Torsional



There's always a solution in steel!

65

## Relative Brace

- A relative column brace system (such as diagonal bracing or shear walls) is attached to two locations along the length of the column that defines the unbraced length. The relative brace system shown consists of the diagonal and the strut that controls the movement at one end of the unbraced length, *A*, with respect to the other end of the unbraced length, *B*.

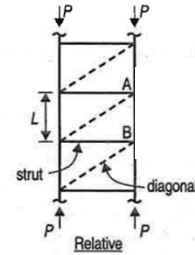

There's always a solution in steel!

66

## Relative and Nodal Braces

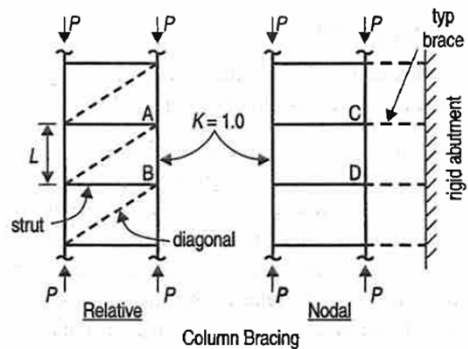

There's always a solution in steel!

67

## Nodal Brace

A nodal brace controls the movement only at the particular brace point, without direct interaction with adjacent braced points. The two nodal column braces at *C* and *D* that are attached to the rigid abutment define the unbraced length for which  $K=1.0$  can be used.

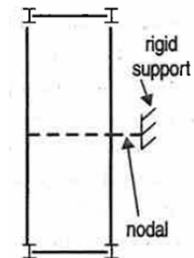

There's always a solution in steel!

68



## Girder Bracing

Typical girder bracing for stability and wind uplift

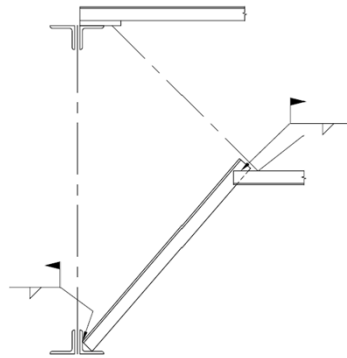

There's always a solution in steel!

69

## Girder Bracing

Typical girder bracing at plastic hinge locations

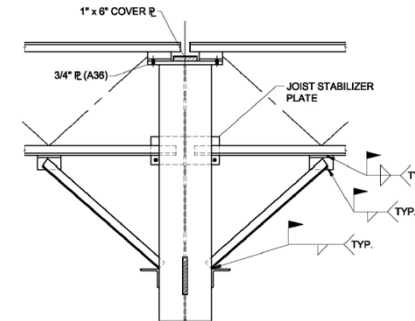

There's always a solution in steel!

70

## Bracing of Sidewall Columns

W30x99

Use AISC Specifications Appendix 6

Two conditions exist for bracing the sidewall columns:

Condition 1: The column exterior flange is in compression, this braced directly by the girts and panels.

Condition 2: The column interior flange is in compression and braced using a flange brace from the girt.

The sidewall columns are functioning primarily as beams thus the beam equations will be used.



There's always a solution in steel!

71

## Bracing of Sidewall Columns

Relative bracing equations are appropriate.

Strength:  $P_{br} = 0.008M_r C_d / h_o$

Stiffness:  $\beta_{br} = \Omega \frac{4M_r C_d}{L_b h_o} (ASD) = \frac{4M_r C_d}{\phi L_b h_o} (LRFD)$

$\Omega = 2.0, \phi = 0.75$

$h_o$  = distance between flange centroids, in.

$C_d$  = 1.0 bending in single curvature

$L_b$  = laterally unbraced length, in.

$M_r$  = required flexural strength, kip-in.



There's always a solution in steel!

72

## Bracing of Sidewall Columns

### Condition 1: Exterior Flange Compression

W30x99

Brace located 7.25 ft  
 from column base

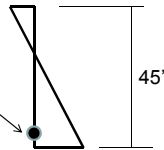

Moment at brace = 272 kip-ft

By inspection the stiffness will satisfy the stiffness equation.

$$P_{br} = 0.008M_r C_d / h_o = (0.008)(272 \text{ k-ft})(12)(1.0) / 29.0 \text{ in.} \\ = 0.90 \text{ kips}$$

Diaphragm strength: 900 lbs/30 ft = 30 lbs/ft

Typical R panel shear value = 140 lbs/ft ok



There's always a solution in steel!

73

## Bracing of Sidewall Columns

### Condition 2: Interior Flange Compression

Brace located 7.25 ft  
 from column base

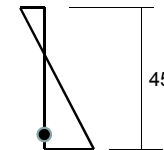

Moment at brace = 235 kip-ft

Determine brace stiffness: End span condition, cont. girts

Use L2x2x3/16 for flange brace,  $A_{brace} = 0.722 \text{ in.}^2$

Z girt (10Z3.25x105),  $A = 1.88 \text{ in.}^2$ ,  $I_x = 28.4 \text{ in.}^4$



There's always a solution in steel!

74

## Bracing of Sidewall Columns

From analysis:

$$\Delta = 0.05 \text{ in.}, P = 1.0 \text{ kips}, \beta_{furnished} = 1.0 / 0.05 = 20 \text{ kips/in.}$$

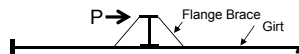

$$\beta_{br} = \Omega \frac{4M_r C_d}{L_b h_o} (ASD) = 2 \frac{(4)(235 \text{ kip-ft})(1.0)}{(7.25 \text{ ft})(29.0 \text{ in.})} = 8.9 \text{ kips/in.}$$

8.9 kips/in. < 20 kips/in. o.k.

$$P_{br} = 0.008M_r C_d / h_o = (0.008)(235 \text{ k-ft})(12)(1.0) / 29.0 \text{ in.} \\ = 0.78 \text{ kips}$$



There's always a solution in steel!

75

## Bracing of Sidewall Columns

Determine Flange Brace Angle Strength:

Length,  $L = (30 \text{ in.})(1.414) = 42.4 \text{ in.}$  (column depth = 30 in.)

$$r_x = 0.612 \text{ in.}^2$$

$$L/r_x = 42.4 \text{ in.} / 0.612 \text{ in.} = 69.0$$

Equivalent slenderness from AISC Section E5

$$KL/r_x = 72 + 0.75(L/r_x) = 72 + (0.75)(69) = 124$$

From Manual Table 4-22:  $F_{cr} / \Omega = 9.59 \text{ ksi}$

$$P_a = (9.59)(0.722) = 6.92 \text{ kips} > (1.414)(0.78) = 1.10 \text{ kips ok}$$



There's always a solution in steel!

76

## The End

---

### End of Lesson 8 and Night School 13



There's always a solution in steel!

77

## Individual Webinar Registrants

---

### PDH Certificates

Within 2 business days...

- You will receive an email on how to report attendance from: [registration@aisc.org](mailto:registration@aisc.org).
- Be on the lookout: Check your spam filter! Check your junk folder!
- Completely fill out online form. Don't forget to check the boxes next to each attendee's name!



There's always a solution in steel!

## Individual Webinar Registrants

---

### PDH Certificates

Within 2 business days...

- New reporting site (URL will be provided in the forthcoming email).
- Username: Same as AISC website username.
- Password: Same as AISC website password.



There's always a solution in steel!

## 8-Session Registrants

---

### PDH Certificates

One certificate will be issued at the conclusion of all 8 sessions.



There's always a solution in steel!

## 8-Session Registrants

---

### FINAL EXAM

The final exam will be issued on Tuesday, April 11.

The final exam must be submitted by Monday, April 24 at 8:00 AM EDT.



There's always a solution in steel!

## 8-Session Registrants

---

### QUIZZES

Access to the quiz: Information for accessing the quiz will be emailed to you by Wednesday. It will contain a link to access the quiz. EMAIL COMES FROM NIGHTSCHOOL@AISC.ORG

Quiz and Attendance records: Posted Tuesday mornings. [www.aisc.org/nightschool](http://www.aisc.org/nightschool) - scroll down to Quiz and Attendance Records.

Reasons for quiz:

EEU – must take all quizzes and final to receive EEU

PDHS – If you watch a recorded session you must take quiz for PDHs.

REINFORCEMENT – Reinforce what you learned tonight. Get more out of the course.

NOTE: If you attend the live presentation, you do not have to take the quizzes to receive PDHs.



There's always a solution in steel!

## 8-Session Registrants

---

### RECORDINGS

Access to the recording: Information for accessing the recording will be emailed to you by this Wednesday. The recording will be available for two weeks. For 8-session registrants only. EMAIL COMES FROM NIGHTSCHOOL@AISC.ORG.

PDHS – If you watch a recorded session you must take AND PASS the quiz for PDHs.



There's always a solution in steel!

## Night School Resources for 8-session package Registrants

---

Find all your handouts, quizzes and quiz scores, recording access, and attendance information all in one place!



There's always a solution in steel!

## Night School Resources for 8-session package Registrants

Go to [www.aisc.org](http://www.aisc.org) and sign in.

The screenshot shows the AISC website homepage. At the top, there are navigation tabs for EDUCATION, PUBLICATIONS, NASCC: THE STEEL CONFERENCE, SAFETY, STEEL SOLUTIONS CENTER, AWARDS AND COMPETITIONS, and RESEARCH LIBRARY. Below the navigation is a large banner with the AISC logo and the text "AISC". Underneath the banner is a "Login" section with a form for entering a username and password. To the right of the login form is a "DON'T HAVE AN ACCOUNT?" section with a "REGISTER NOW" button.

## Night School Resources for 8-session package Registrants

The screenshot shows the MyAISC user profile page. On the left, there is a sidebar menu with options: Edit Profile, My Downloads, My Pending Quizzes, My Events, Order History, Course History, and Night School Resources. The "Night School Resources" option is circled in red. The main content area shows the "MY PROFILE" section with an "EDIT PROFILE" button. Below that is the "MY PURCHASED DOWNLOADS" section. Further down is the "MY ORDER HISTORY" section with a "VIEW ORDERS" button. At the bottom, there is a "MY NIGHT SCHOOL RESOURCES" section with a "VIEW RESOURCES" button, which is also circled in red.

## Night School Resources for 8-session package Registrants

The screenshot shows the AISC website page for "Night School Resources". The page features the AISC logo and the text "AISC". Below the logo is a navigation bar with tabs for EDUCATION, PUBLICATIONS, NASCC: THE STEEL CONFERENCE, SAFETY, STEEL SOLUTIONS CENTER, AWARDS AND COMPETITIONS, and RESEARCH LIBRARY. The main content area is titled "Night School Resources" and contains a table with the following information:

Event	Date
<a href="#">NS13.8-Session Package</a>	1/30/2017 7:00:00 PM

At the bottom of the page, there is a small AISC logo and the text "There's always a solution in steel!"

## Night School Resources for 8-session package Registrants

The screenshot shows the AISC website page for "Night School 13: Design of Industrial Buildings". The page features the AISC logo and the text "AISC". Below the logo is a navigation bar with tabs for EDUCATION, PUBLICATIONS, NASCC: THE STEEL CONFERENCE, SAFETY, STEEL SOLUTIONS CENTER, AWARDS AND COMPETITIONS, and RESEARCH LIBRARY. The main content area is titled "Night School 13: Design of Industrial Buildings" and contains a table of "8-SESSION PACKAGE RESOURCES".

Event	Date	Handouts	Video	Quiz	Attendance
NS13 - Design Criteria	1/30/2017 7:00:00 PM	<a href="#">Handouts</a>	<a href="#">Video</a>	Pass Score: 80	Pending
NS13 - Economic Considerations	2/6/2017 7:00:00 PM	<a href="#">Handouts</a>	Available 02/08/2017 5pm EST	Available 02/08/2017 5pm EST	Pending
NS13 - Lateral Load Systems and Details	2/13/2017 7:00:00 PM	<a href="#">Handouts</a>	Available 02/15/2017 5pm EST	Available 02/15/2017 5pm EST	Pending
NS13 - Preliminary Design Procedures	2/27/2017 7:00:00 PM	<a href="#">Handouts</a>	Available 03/01/2017 5pm EST	Available 03/01/2017 5pm EST	Pending
NS13 - Crane Greder Design and Frame Analysis	3/6/2017 7:00:00 PM	<a href="#">Handouts</a>	Available 03/08/2017 5pm EST	Available 03/08/2017 5pm EST	Pending
NS13 - Frame Member and Connection Design	3/13/2017 7:00:00 PM	<a href="#">Handouts</a>	Available 03/15/2017 5pm EST	Available 03/15/2017 5pm EST	Pending
NS13 - Transfer Crane Gider & Longitudinal Brg Bracing Dcn	3/27/2017 7:00:00 PM	<a href="#">Handouts</a>	Available 03/29/2017 5pm EST	Available 03/29/2017 5pm EST	Pending
NS13 - Building Envelope and Bracing Design	4/3/2017 7:00:00 PM	<a href="#">Handouts</a>	Available 04/05/2017 5pm EST	Available 04/05/2017 5pm EST	Pending
NS13 - Final Exam	4/10/2017 7:00:00 PM			Available 04/12/2017 5pm EST	



## Night School Resources for 8-session package Registrants

- Weekly “quiz and recording” email.
- Weekly updates of the master Quiz and Attendance record found at [www.aisc.org/nightschool](http://www.aisc.org/nightschool). Scroll down to Quiz and Attendance records.
  - Updated on Tuesday mornings.



There's always a solution in steel!

## Night School Resources for 8-session package Registrants

- Webinar connection information:
  - Found in your registration confirmation/receipt.
  - Reminder email sent out Monday mornings.
- Link to handouts also found here.



There's always a solution in steel!

## Thank You

Please give us your feedback!  
*Survey at conclusion of webinar.*

There's always a solution in steel.

