



Thank you for joining our live webinar today.
We will begin shortly. Please standby.



Thank you.

Need Help?
Call ReadyTalk Support: 800.843.9166



Today's audio will be broadcast through the internet.



Alternatively, to hear the audio through the phone, dial 888-504-7949. Passcode: 660099



Today's live webinar will begin shortly.
Please standby.

As a reminder, all lines have been muted. Please type any questions or comments through the Chat feature on the left portion of your screen.

Today's audio will be broadcast through the internet.
Alternatively, to hear the audio through the phone, dial 888-504-7949.
Passcode: 660099



AISC is a Registered Provider with The American Institute of Architects Continuing Education Systems (AIA/CES). Credit(s) earned on completion of this program will be reported to AIA/CES for AIA members. Certificates of Completion for both AIA members and non-AIA members are available upon request.

This program is registered with AIA/CES for continuing professional education. As such, it does not include content that may be deemed or construed to be an approval or endorsement by the AIA of any material of construction or any method or manner of handling, using, distributing, or dealing in any material or product.

Questions related to specific materials, methods, and services will be addressed at the conclusion of this presentation.





Copyright Materials

This presentation is protected by US and International Copyright laws. Reproduction, distribution, display and use of the presentation without written permission of AISC is prohibited.

© The American Institute of Steel Construction 2017



Course Description

June 12, 2017 – Fundamentals of Stability for Steel Design: Design of Compression Members

Initially, an overview of flexural, torsional, and flexural-torsional resistance of individual column members will be provided. Emphasis then will be placed on defining and assessing the AISC LRFD and ASD strengths of various structural shapes, including wide flange, round and square HSS, cruciform, equal and unequal single and double leg angles, WT, channel, and built-up shapes.



Learning Objectives

- Explain the design limit states of flexural, torsional, and flexural-torsional buckling resistance of compression members
- Identify the steps to determine the design strengths for column design using the AISC *Specification*.
- Identify the applicable buckling limit states for various structural shapes subjected to compression.
- Understand stability design through the use of design examples.



Fundamentals of Stability for Steel Design Session 2: Design of Compression Members

June 12, 2017



Presented by
Perry S. Green, P.E., Ph.D.
Bechtel Corporation, Waynesboro, GA

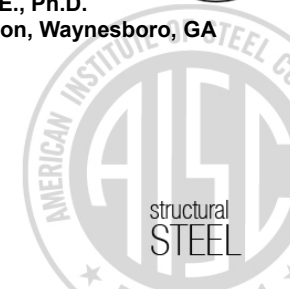

There's always a solution in steel.





There's always a solution in steel.

Fundamentals of Stability for Steel Design

Session 2 Design of Compression Members

Perry S. Green, P.E., Ph.D.



SESSION OUTLINE

- **Introduction**
- **Flexural Buckling**
- **Torsional Buckling**
- **Flexural-Torsional Buckling**
- **Built-Up Members**
- **Design Examples:**
 - Flexural Buckling**
 - Torsional Buckling**
 - Flexural-Torsional Buckling**

10

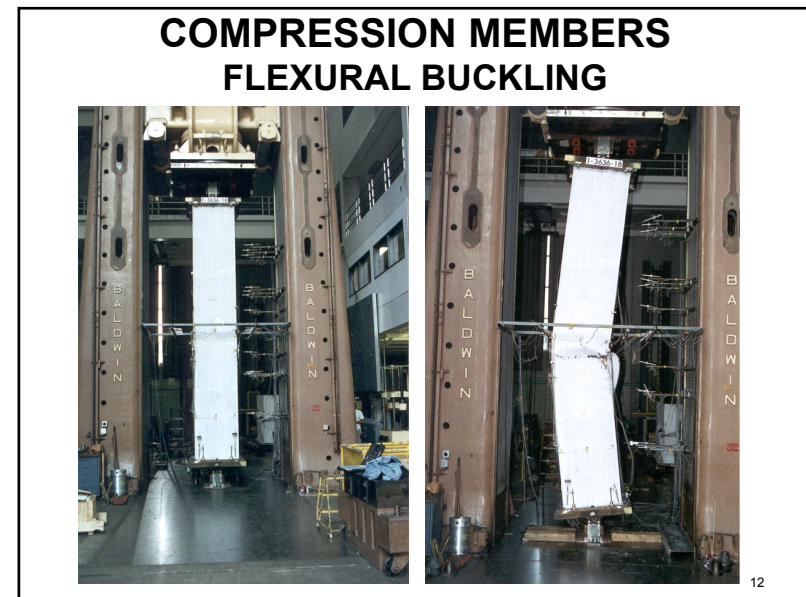

2010 AISC SPECIFICATION CHAPTER E - COMPRESSION MEMBERS

- All compression member strengths are controlled by the limit state of *buckling*

Bad News

There are four different types of buckling

FB: Flexural Buckling

TB: Torsional Buckling

FTB: Flexural-Torsional Buckling

LB: Local Plate Buckling

Good News

Not all types are applicable to every member

13

ANSI/AISC 360-10 *Specification for the Design of Steel Buildings, 2010*

CHAPTER E

DESIGN OF MEMBERS FOR COMPRESSION

- E1. GENERAL PROVISIONS
- E2. EFFECTIVE LENGTH
- E3. FLEXURAL BUCKLING OF MEMBERS WITHOUT SLENDER ELEMENTS**
- E4. TORSIONAL AND FLEXURAL-TORSIONAL BUCKLING OF MEMBERS WITHOUT SLENDER ELEMENTS**
- E5. SINGLE ANGLE COMPRESSION MEMBERS**
- E6. BUILT-UP MEMBERS**
- E7. MEMBERS WITH SLENDER ELEMENTS

14

2010 AISC SPECIFICATION CHAPTER E - COMPRESSION MEMBERS

FB: Flexural Buckling

TB: Torsional Buckling

FTB: Flexural-Torsional Buckling

~~**LB:** Local Plate Buckling~~

only for members with slender plate elements

Cross Section	Without Slender Elements	
	Sections in Chapter E	Limit States
	E3 E4	FB TB
	E3 E4	FB FTB
	E3	FB
	E3	FB
	E3 E4	FB FTB
	E3 E4 E6	FB FTB
	E5	FB TB
	E3	FB
Unsymmetrical shapes other than single angles	E4	FTB

TYPES OF COMPRESSION MEMBERS

- Doubly-symmetric Members

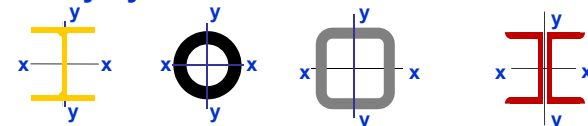

- Singly-symmetric Members

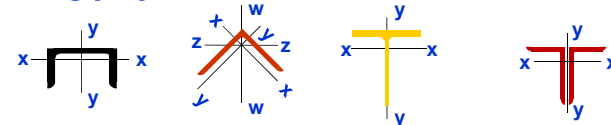

- Unsymymmetric Members

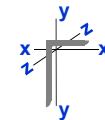

16



FLEXURAL BUCKLING DOUBLY-SYMMETRIC MEMBERS

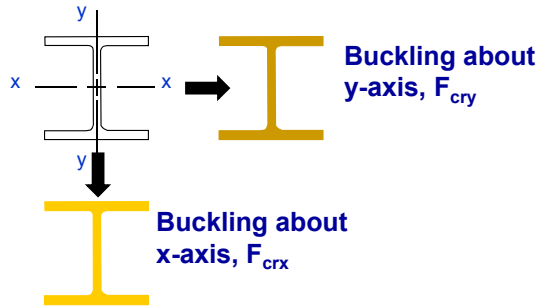

Most cases in design of W Shapes involve flexural buckling

17

2010 AISC SPECIFICATION CHAPTER E - COMPRESSION MEMBERS

CROSS SECTION	WITHOUT SLENDER ELEMENTS	
	SECTIONS IN CHAPTER E	LIMIT STATES
	E3 E4	FB TB

FB: Flexural Buckling
TB: Torsional Buckling
FTB: Flexural-Torsional Buckling

For doubly-symmetric I shapes *flexural buckling* will always control if twist of the member is prevented at all supports and brace points, *i.e.*, the lateral unbraced length \geq torsional unbraced length

18

INEFFECTIVE TORSIONAL SUPPORT

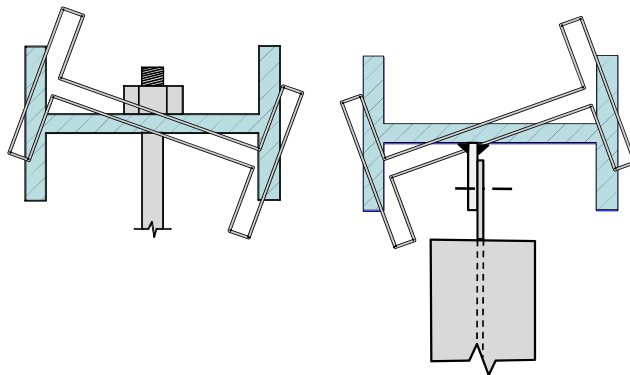

Torsional Buckling will be discussed later

19

COMPRESSION MEMBERS FLEXURAL BUCKLING W/O SLENDER ELEMENTS

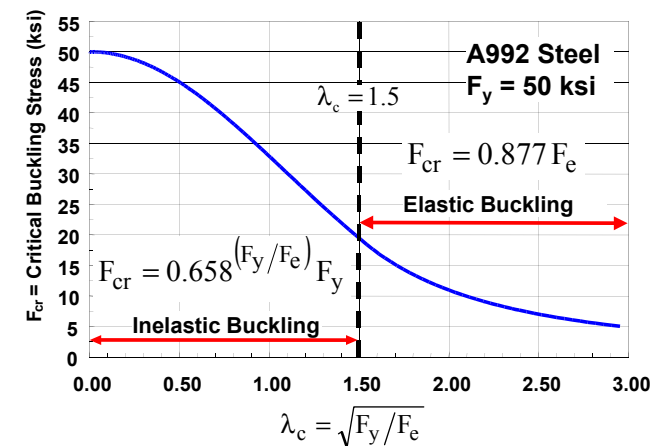

20



COMPRESSION MEMBERS

FLEXURAL BUCKLING W/O SLENDER ELEMENTS

ANSI/AISC 360-10 Specification for the Design of Steel Buildings, 2010

YES

NO

$$P_n = F_{cr} A_g \quad (E3-1)$$

$$F_{cr} = \left[0.658^{\frac{F_y}{F_e}} \right] F_y \quad (E3-2)$$

$$F_e = \frac{\pi^2 E}{\left(\frac{KL}{r} \right)^2} \quad (E3-4)$$

$$F_{cr} = 0.877 F_e \quad (E3-3)$$

21

COMPRESSION MEMBER DESIGN EXAMPLE 1

*ANSI/AISC 360-10 Specification
for the Design of Steel Buildings, 2010*

22

WF MEMBER DESIGN STRENGTH

$P_D = 125$ kips

$P_L = 400$ kips

$P_a = 525$ kips

$P_u = 790$ kips

Check Required Strength W12 x 96

$A_g = 28.2$ in.² $I_y = 270$ in.⁴ $r_y = 3.09$ in.

$F_y = 50$ ksi $KL_y = 240$ in.

20'

$$F_e = \frac{\pi^2 E}{\left(\frac{KL}{r} \right)^2} = \frac{\pi^2 (29000)}{\left(\frac{240}{3.09} \right)^2} = 47.44 \text{ ksi} \quad (E3-4)$$

$$\frac{F_y}{F_e} = \frac{50}{47.44} = 1.05 \leq 2.25 \quad \therefore \text{Inelastic}$$

$$F_{cr} = \left[0.658^{\frac{F_y}{F_e}} \right] F_y = \left[0.658^{1.05} \right] (50) = 32.17 \text{ ksi} \quad (E3-2)$$

$$P_n = F_{cr} A_g = (32.17)(28.2) = 907.0 \text{ kips} \quad (E3-1)$$

$$\frac{P_n}{\Omega_c} = \frac{907}{1.67} = 543 \text{ kips} > 525 \text{ kips} \quad \therefore \text{OK}$$

$$\phi_c P_n = 0.9(907) = 816 \text{ kips} > 790 \text{ kips} \quad \therefore \text{OK}$$

NOTE: From the Column Strength Tables $\phi_c P_n = 816$ kips

23

POTENTIAL BUCKLING MODES

Flexural Buckling

Section A-A

Torsional Buckling

Section B-B

24

2010 AISC SPECIFICATION CHAPTER E - COMPRESSION MEMBERS

CROSS SECTION	WITHOUT SLENDER ELEMENTS	
	SECTIONS IN CHAPTER E	LIMIT STATES
	E3 E4	FB TB

FB: Flexural Buckling

TB: Torsional Buckling

FTB: Flexural-Torsional Buckling

Torsional buckling occurs over short lengths

- Usually KL/r will be less than approximately 50
- Doubly-symmetric section
- Wide flange, cruciform, and point symmetric sections

25

TORSIONAL BUCKLING OPEN CROSS SECTION MEMBERS

- Buckling in a torsional mode (torsion of non-circular sections involves torsional shear and warping):
 - K_z is normally taken as 1.0
 - Effective length in torsion is $K_z L_z = L_z$
 - Function of the torsional constant $J \approx \Sigma(bt^3/3)$
 - Capacity of section with warping stiffness is a function of warping constant C_w
 - C_w , J , r_x , r_y are given in the Properties Tables where x and y are the axes of symmetry of the section
 - $E = 29,000$ ksi, $G = 0.385E$ (11,200 ksi)

26

COMPRESSION MEMBERS TORSIONAL BUCKLING W/O SLENDER ELEMENTS

ANSI/AISC 360-10 *Specification for the Design of Steel Buildings, 2010*

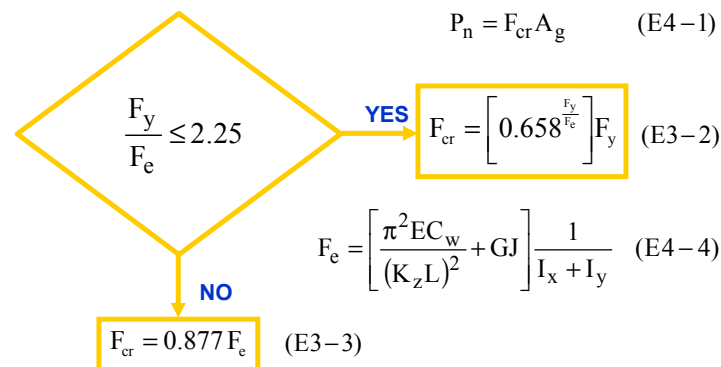

27

COMPRESSION MEMBER DESIGN EXAMPLE 2

ANSI/AISC 360-10 *Specification for the Design of Steel Buildings, 2010*



28



TORSIONAL BUCKLING EXAMPLE

Are the columns stable with the 140 k factored load if bracing at midheight is supplied by tie rods?

Columns: W16x26; $F_y = 50$ ksi; $P_y = 384$ kips
 $I_y = 9.59$ in⁴; $J = 0.26$ in⁴; $A_g = 7.68$ in²
 $I_x = 301$ in⁴; $C_w = 565$ in⁶
 Flexural Buckling Effective Length: $L_y = 10$ ft
 $\phi P_n = 150$ kips $>$ 140 kips \therefore OK

29

TORSIONAL BUCKLING EXAMPLE

Torsional Buckling
Effective Length: $L_T = 20$ ft.

$$F_e = \left[\frac{\pi^2 (29000)(565)}{(20 \times 12)^2} + 11200(0.262) \right] \frac{1}{(301 + 9.59)} = 18.5 \text{ ksi} \quad (E4-4)$$

$$\frac{F_y}{F_e} = \frac{50}{18.5} = 2.70 > 2.25 \therefore \text{Elastic} \quad F_{cr} = 0.877(18.5) = 16.2 \text{ ksi} \quad (E3-3)$$

$$P_{Tn} = F_{cr} A_g = (16.2)(7.68) = 124.4 \text{ kips} \quad (E4-1)$$

$$\phi_c P_{Tn} = 0.9(124.4) = 112 \text{ kips} < 140 \text{ kips} \quad \therefore \text{NG}$$

Note: If $L_T = 10$ ft., $P_T = 283$ k

30

2010 AISC SPECIFICATION CHAPTER E - COMPRESSION MEMBERS

CROSS SECTION	WITHOUT SLENDER ELEMENTS	
	SECTIONS IN CHAPTER E	LIMIT STATES
	E5	FB TB FTB

FB: Flexural Buckling
TB: Torsional Buckling
FTB: Flexural-Torsional Buckling

31

TORSIONAL BUCKLING EQUAL LEG ANGLE MEMBERS

$$P_{crz} = \frac{GJA}{I_p}$$

$$A = 2bt, \quad J = 2 \frac{bt^3}{3}$$

$$I_p = 2 \frac{b^3 t}{3}, \quad C_w \approx 0$$

$$P_{crz} = \frac{2Gt^3}{b}$$

Observations:
 Torsional buckling is not a function of the angle length
 The buckling capacity decreases for large leg sizes

32

TORSIONAL BUCKLING EQUAL LEG ANGLE MEMBERS

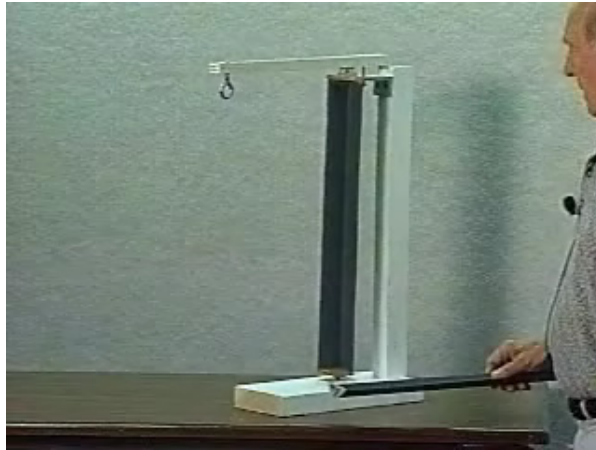

33

2010 AISC SPECIFICATION CHAPTER E - COMPRESSION MEMBERS

CROSS SECTION	WITHOUT SLENDER ELEMENTS	
	SECTIONS IN CHAPTER E	LIMIT STATES
	E3 E4 E6	FB FTB

FB: Flexural Buckling

TB: Torsional Buckling

FTB: Flexural-Torsional Buckling

34

FLEXURAL-TORSIONAL BUCKLING SINGLY AND UNSYMMETRIC MEMBERS

- Flexural buckling will occur in the plane of symmetry
- Sections always rotate about the shear center; the shear center lies on the axis of symmetry
- Singly symmetric sections can buckle either in a Flexural or Flexural-Torsional mode
- Flexural-Torsional buckling will occur by twisting about a point in the plane of symmetry
- Unsymmetric sections will always buckle in a Flexural-Torsional mode

35

FLEXURAL-TORSIONAL BUCKLING SINGLY AND UNSYMMETRIC MEMBERS

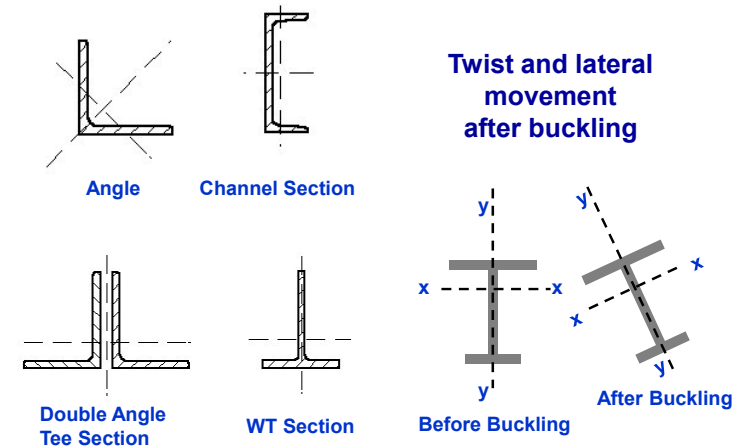

36



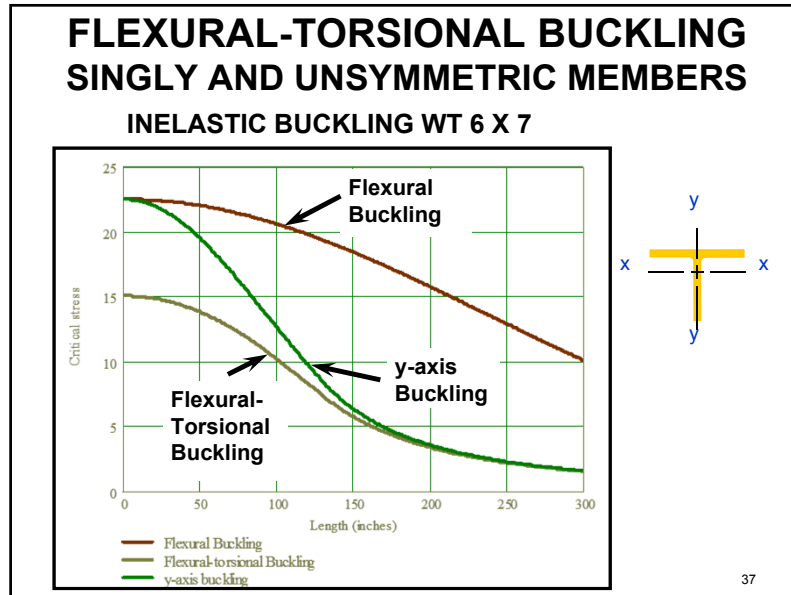

POLLING QUESTION 1

38

COMPRESSION MEMBERS BUCKLING OF SINGLE ANGLES WITH OR W/O SLENDER ELEMENTS

AISC/LRFD Specification for Single Angle Members (Nov. 10, 2000) permitted design for L/r_z only. OK for usual dimensions, but can be unconservative for short single angles

The 2005 AISC Specification recommended using effective length formulas from ASCE Transmission Line Standard for single angle columns attached to a gusset plate to one leg

See the SSRC Guide to Stability Design Criteria for Metal Structures Chapter 11 for more info

39

- ### COMPRESSION MEMBERS BUCKLING OF SINGLE ANGLES WITH OR W/O SLENDER ELEMENTS
- **The effects of eccentricity on single angle members are permitted to be neglected when the members are evaluated as axially loaded compression members using one of the effective slenderness ratios specified below, provided that:**
 - Members are loaded at the ends in compression through the same one leg
 - Members are attached by welding or by minimum two-bolt connections; and
 - No intermediate transverse loads are present
- 40



COMPRESSION MEMBERS EQUIVALENT KL/r FOR SINGLE ANGLES

Case 1 - E5(a): Planar truss, attachment to chord or gusset plate

$\frac{L}{r_x} \leq 80$

YES

$\frac{KL}{r} = 72 + 0.75 \frac{L}{r_x}$ (E5-1)

NO

$\frac{KL}{r} = 32 + 1.25 \frac{L}{r_x}$ (E5-2)

41

COMPRESSION MEMBERS EQUIVALENT KL/r FOR SINGLE ANGLES

Additional requirements for unequal leg angles:

$$\left(\frac{KL}{r}\right)_{eq} \geq 0.95 \frac{L}{r_z}$$

For unequal leg angles with $b_{long}/b_{short} < 1.7$ where attachment is to the shorter leg, increase

$$\left(\frac{KL}{r}\right)_{eq} \text{ by } 4 \left[\left(\frac{b_{long}}{b_{short}}\right)^2 - 1 \right]$$

42

COMPRESSION MEMBERS EQUIVALENT KL/r FOR SINGLE ANGLES

Case 2 - E5(b): Box or space truss

$\frac{L}{r_x} \leq 75$

YES

$\frac{KL}{r} = 60 + 0.80 \frac{L}{r_x}$ (E5-3)

NO

$\frac{KL}{r} = 45 + \frac{L}{r_x}$ (E5-4)

43

COMPRESSION MEMBERS EQUIVALENT KL/r FOR SINGLE ANGLES

Additional requirements for unequal leg angles:

$$\left(\frac{KL}{r}\right)_{eq} \geq 0.82 \frac{L}{r_z}$$

For unequal leg angles with $b_{long}/b_{short} < 1.7$ where attachment is to the shorter leg, increase

$$\left(\frac{KL}{r}\right)_{eq} \text{ by } 6 \left[\left(\frac{b_{long}}{b_{short}}\right)^2 - 1 \right]$$

44



COMPRESSION MEMBER DESIGN EXAMPLE 3

*ANSI/AISC 360-10 Specification
for the Design of Steel Buildings, 2010*



45

MEMBER DESIGN STRENGTH SINGLE ANGLE COLUMN L 2 x 2 x 3/16

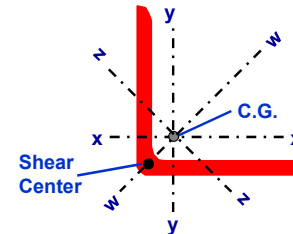

Section Properties:

$A = 0.722 \text{ in.}^2$
 $r_x = 0.612 \text{ in.}$
 $r_z = 0.389 \text{ in.}$
 $Q_s = 1.0$

Compression Member
Length: $L = 44 \text{ in.}$

Material Properties:

$F_y = 36 \text{ ksi or } 50 \text{ ksi}$
 $E = 29,000 \text{ ksi}$
 $G = 0.385 E$

An equal leg angle is welded to the web of tee chords of a planar truss. Is it more advantageous to use 50 ksi material rather than 36 ksi yield strength material?

46

MEMBER DESIGN STRENGTH SINGLE ANGLE COLUMN L 2 x 2 x 3/16

Effective Slenderness

$$\frac{b}{t} = \frac{2}{0.1875} = 10.7 < 20$$

$$\frac{L}{r_x} = \frac{44}{0.612} = 72 < 80$$

$$\left(\frac{KL}{r}\right)_x = 72 + 0.75 \frac{L}{r_x} = 126 \leq 4.71 \sqrt{\frac{E}{F_y}} = 133 \quad (\text{E5-1})$$

Details:

Equal leg angle
One leg connected to tee chord
Attached by welding
Width-to-thickness ratio meets
criteria in Section E5
 $F_y = 36 \text{ ksi}$

47

MEMBER DESIGN STRENGTH SINGLE ANGLE COLUMN L 2 x 2 x 3/16

$$F_c = \frac{\pi^2 E}{\left(\frac{KL}{r}\right)^2} = 18.03 \text{ ksi} \quad (\text{E3-4})$$

$$F_{cr} = \left[0.658 \frac{F_y}{F_c} \right] F_y = 15.60 \text{ ksi} \quad (\text{E3-2})$$

$$P_n = F_{cr} A_g = 11.27 \text{ kips} \quad (\text{E3-1})$$

➔ ASD $\frac{P_n}{\Omega} = 6.75 \text{ kips}$ LRFD $\phi P_n = 10.14 \text{ kips}$

Single angle will buckle inelastically in a flexural mode

48



MEMBER DESIGN STRENGTH SINGLE ANGLE COLUMN L 2 x 2 x 3/16

Effective Slenderness

$$\frac{b}{t} = \frac{2}{0.1875} = 10.7 < 20$$

Details:
 All same except
 $F_y = 50$ ksi

$$\frac{L}{r_x} = \frac{44}{0.612} = 72 < 80$$

$$\left(\frac{KL}{r}\right)_x = 72 + 0.75 \frac{L}{r_x} = 126 > 4.71 \sqrt{\frac{E}{F_y}} = 113 \quad (E5-1)$$

49

MEMBER DESIGN STRENGTH SINGLE ANGLE COLUMN L 2 x 2 x 3/16

$$F_e = \frac{\pi^2 E}{\left(\frac{KL}{r}\right)^2} = 18.03 \text{ ksi} \quad (E3-4)$$

$$F_{cr} = 0.877 F_e = 15.81 \text{ ksi} \quad (E3-2)$$

$$P_n = F_{cr} A_g = 11.41 \text{ kips} \quad (E3-1)$$

➔ ASD $\frac{P_n}{\Omega} = 6.83$ kips LRFD $\phi P_n = 10.27$ kips

Single angle will buckle elastically in a flexural mode
 NOTE: Design strength has only increased about 1%

50

COMPRESSION MEMBERS BUILT-UP COLUMNS

- **Built-up members are comprised of two or more sections**
 - Stitch bolts
 - Batten plates
 - Lacing
 - Combined batten plates and lacing
 - Perforated cover plates
- **Built-up batten member buckling is somewhat similar to frame buckling**
 - Battens act like beams
 - Battens get shear and moment due to the bending of the frame like built-up member at the time of buckling

COMPRESSION MEMBERS BUILT-UP LACED OR BATTEN COLUMNS

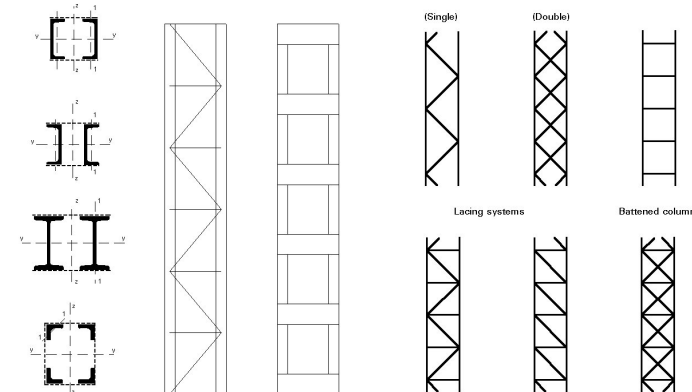

See the *SSRC Guide to Stability Design Criteria for Metal Structures Chapter 3* for more info

52

COMPRESSION MEMBERS BUCKLING OF BUILT-UP MEMBERS COMPOSED OF TWO SHAPES

(a) For intermediate connectors that are bolted snug-tight

$$\left(\frac{KL}{r}\right)_m = \sqrt{\left(\frac{KL}{r}\right)_o^2 + \left(\frac{a}{r_i}\right)^2} \quad (E6-1)$$

a = distance between connectors (in.)
 r_i = minimum radius of gyration of individual component (in.)

$\left(\frac{KL}{r}\right)_m$ = modified slenderness of built-up member
 $\left(\frac{KL}{r}\right)_o$ = slenderness ratio of built-up member acting as a unit in the buckling direction being considered

53

COMPRESSION MEMBERS BUCKLING OF BUILT-UP MEMBERS COMPOSED OF TWO SHAPES

(b) For intermediate connectors that are welded or are connected by means of pretensioned bolts

$\frac{a}{r_i} \leq 40$

YES →

$\left(\frac{KL}{r}\right)_m = \left(\frac{KL}{r}\right)_o \quad (E6-2a)$

NO ↓

$\left(\frac{KL}{r}\right)_m = \sqrt{\left(\frac{KL}{r}\right)_o^2 + \left(\frac{K_i a}{r_i}\right)^2} \quad (E6-2b)$

$K_i = 0.50$	
$= 0.75$	
$= 0.86$	all others

54

COMPRESSION MEMBER DESIGN EXAMPLE 4

*ANSI/AISC 360-10 Specification
 for the Design of Steel Buildings, 2010*

55

MEMBER DESIGN STRENGTH DIAGONAL BRACE 2L s 6 x 4 x 5/8 LLBB

What is the design strength of the 14 ft. long diagonal brace that is comprised of 2L's 6 x 4 x 5/8 LLBB, A36 steel.

There are two intermediate bolted connectors at a spacing of 56 in. Use $K = 1.0$

56

MEMBER DESIGN STRENGTH DIAGONAL BRACE 2L s 6 x 4 x 5/8 LLBB

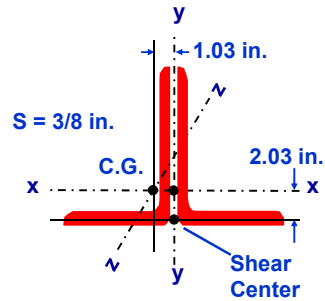

Material Properties

$$F_y = 36 \text{ ksi}$$

$$E = 29,000 \text{ ksi}$$

$$G = 0.385 E$$

Single Angle Section Properties

$$J = 0.775 \text{ in.}^4 \quad C_w = 1.59 \text{ in.}^6$$

$$r_z = 0.859 \text{ in.} \quad r_{yi} = 1.13 \text{ in.}$$

Double Angle Section Properties

$$A = 11.7 \text{ in.}^2 \quad I_x = 42.0 \text{ in.}^4$$

$$r_x = 1.89 \text{ in.} \quad r_y = 1.66 \text{ in.}$$

$$\bar{r}_0 = 3.05 \text{ in.} \quad J = 1.55 \text{ in.}^4$$

$$H = 0.684 \text{ in.}$$

57

MEMBER SLENDERNESS DIAGONAL BRACE 2L s 6 x 4 x 5/8 LLBB

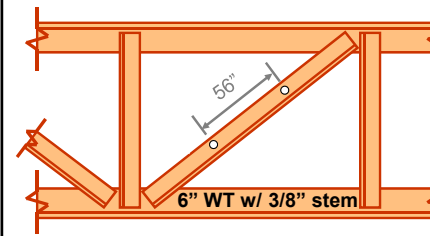

$$x-x \text{ axis: } KL/r_x = 88.9$$

$$z-z \text{ axis: } a/r_z = 65.2$$

$$y-y \text{ axis: } KL/r_y = 101.2$$

The intermediate connectors are only snug-tight
Determine the design strength neglecting flexural-torsional buckling;
Y-Y axis is built-up and acts as a single unit, therefore,

$$\left(\frac{KL}{r}\right)_m = \sqrt{\left(\frac{KL}{r}\right)_o^2 + \left(\frac{a}{r_i}\right)^2} \quad (E6-1)$$

58

MEMBER DESIGN STRENGTH DIAGONAL BRACE 2L s 6 x 4 x 5/8 LLBB

$$\left(\frac{KL}{r}\right)_m = \sqrt{\left(\frac{KL}{r}\right)_o^2 + \left(\frac{a}{r_i}\right)^2} = \sqrt{(101.2)^2 + (65.2)^2} = 120.38$$

$$F_{ey} = \frac{\pi^2 E}{\left(\frac{KL}{r}\right)_m^2} = 19.75 \text{ ksi} \quad F_y/F_{ey} = 36/19.75 = 1.82 < 2.25$$

$$F_{cry} = 0.658 \frac{F_y}{F_e} F_y = 16.79 \text{ ksi}$$

$$P_n = A_g F_{cr} = (11.7)(16.79) = 196.4 \text{ kips}$$

59

MEMBER SLENDERNESS DIAGONAL BRACE 2L s 6 x 4 x 5/8 LLBB

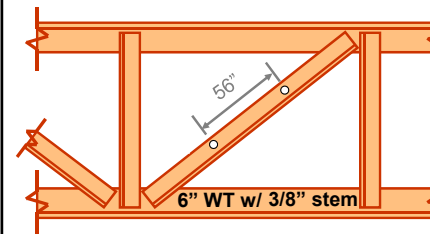

$$x-x \text{ axis: } KL/r_x = 88.9$$

$$z-z \text{ axis: } a/r_z = 65.2$$

$$y-y \text{ axis: } KL/r_y = 101.2$$

$$\frac{a}{r_i} = \frac{56}{0.859} = 65.2 > 40$$

The intermediate connectors are pretensioned
Determine the design strength neglecting flexural-torsional buckling;
Y-Y axis is built-up and acts as a single unit, therefore,

$$\left(\frac{KL}{r}\right)_m = \sqrt{\left(\frac{KL}{r}\right)_o^2 + \left(\frac{K_i a}{r_i}\right)^2} \quad (E6-2b)$$

60

MEMBER DESIGN STRENGTH DIAGONAL BRACE 2L s 6 x 4 x 5/8 LLBB

$$\left(\frac{KL}{r}\right)_m = \sqrt{\left(\frac{KL}{r}\right)_o^2 + \left(\frac{K_1 a}{r_1}\right)^2}$$

$$= \sqrt{(101.2)^2 + [(0.5)(65.2)]^2} = 106.3$$

$$F_{ey} = \frac{\pi^2 E}{\left(\frac{KL}{r}\right)_y^2} = 25.32 \text{ ksi} \quad F_y / F_{ey} = 36 / 25.32 = 1.42 < 2.25$$

$$F_{cry} = 0.658 F_e F_y = 19.85 \text{ ksi}$$

$$P_n = A_g F_{cr} = (11.7)(19.85) = 232.3 \text{ kips} \leftarrow \text{Use}$$

61

DETERMINATION OF CRITICAL STRESS DIAGONAL BRACE 2L s 6 x 4 x 5/8 LLBB

Flexural-Torsional Buckling

$$F_{crz} = \left(\frac{\pi^2 EC_w}{(K_z L)^2} + GJ \right) \frac{1}{A_g \bar{r}_o^2} \cong \frac{GJ}{A_g \bar{r}_o^2} \quad (E4-3)$$

Small compared to GJ, therefore this term can be safely ignored for angles, double angles and tees. In this case, 32 versus 17360

$$F_{crz} = \frac{GJ}{A_g \bar{r}_o^2} = \frac{(11200)(1.55)}{(11.7)(3.05)^2} = 159.5 \text{ ksi}$$

$$F_{cr} = \frac{F_{cry} + F_{crz}}{2H} \left[1 - \sqrt{1 - \frac{4F_{cry}F_{crz}H}{(F_{cry} + F_{crz})^2}} \right] \quad (E4-2)$$

62

MEMBER DESIGN STRENGTH DIAGONAL BRACE 2L s 6 x 4 x 5/8 LLBB

$$F_{cr} = \frac{19.85 + 159.5}{2(0.684)} \left[1 - \sqrt{1 - \frac{4(19.85)(159.5)(0.684)}{(19.85 + 159.5)^2}} \right]$$

$$F_{cr} = 19.0 \text{ ksi}$$

$$P_n = A_g F_{cr} = (11.7)(19.0) = 222.4 \text{ kips}$$

$$\text{ASD } \frac{P_n}{\Omega} = 133.2 \text{ kips} \quad \text{LRFD } \phi P_n = 200.10 \text{ kips}$$

The Flexural-Torsional buckling load is ~5% less than the Euler buckling load in this case. If the legs of the angles or stem of the tees are thin, Flexural-Torsional buckling could be up to 20% less than the Flexural buckling load.

63

COMPRESSION MEMBERS BUILT-UP COLUMNS

Effect of Connector End Restraint on the Behavior of Built-up Columns - Consider Three Cases:

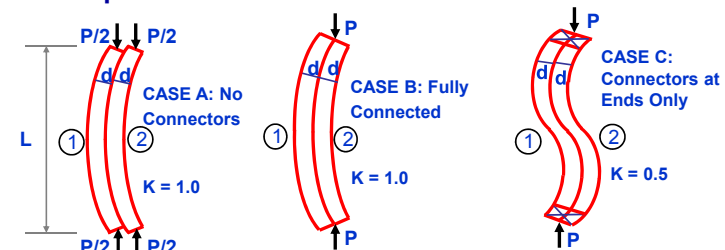

$$\frac{P_{cr}}{2} = \frac{\pi^2 E \left(\frac{1}{12} b d^3\right)}{L^2}$$

$$P_{cr} = \frac{\pi^2 E b d^3}{6 L^2}$$

$$P_{cr} = \frac{\pi^2 E \left(\frac{1}{12} b (2d)^3\right)}{L^2}$$

$$P_{cr} = \frac{4 \pi^2 E b d^3}{6 L^2}$$

$$\frac{P_{cr}}{2} = \frac{\pi^2 E \left(\frac{1}{12} b d^3\right)}{(0.5L)^2}$$

$$P_{cr} = \frac{4 \pi^2 E b d^3}{6 L^2}$$

64



COMPRESSION MEMBERS BUILT-UP COLUMNS

CASE A: With no connectors, I_{eff} of the cross-section is the sum of the I of the individual components,
 $I_{eff} = 2 \left[\frac{1}{12} b d^3 \right]$.

CASE B: With the two components fully connected, no slip occurs between members, the cross-section acts as a single unit and $I_{eff} = \frac{1}{12} b (2d)^3$ or four times that with no connectors.

CASE C: Providing just a few connectors will give an effective member stiffness somewhere between these two extremes. The maximum effect will occur when connectors are placed near the ends where the relative displacement between the contact surfaces would be a maximum. Connections near midspan will have no effect.

65

COMPRESSION MEMBERS BUILT-UP COLUMNS

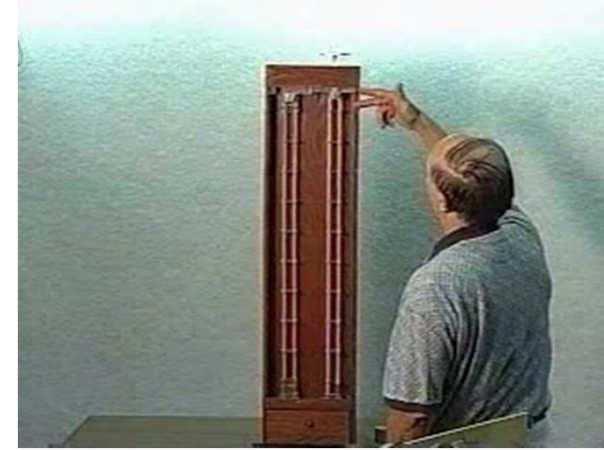

66

COMPRESSION MEMBERS BUILT-UP COLUMNS

Shear Connector Design Requirements for Slip

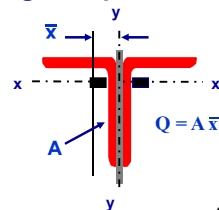
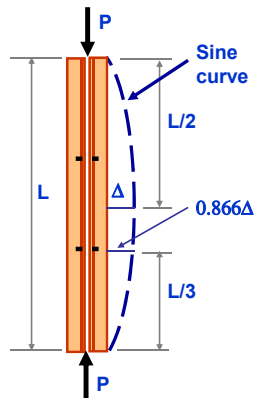

$$\text{Total Shear Force} = P \Delta \frac{Q}{I_y}$$

$$\Delta = \frac{\Delta_0}{1 - \frac{P}{P_{cr}}}$$

where $\Delta_0 = 0.001L$ and $P/P_{cr} = 0.877$, then

$$\text{Required Slip Resistance} = 0.008 P_u L \frac{Q}{I_y}$$

67

COMPRESSION MEMBERS BUILT-UP COLUMNS

Shear Force Distribution Along Length of the Column

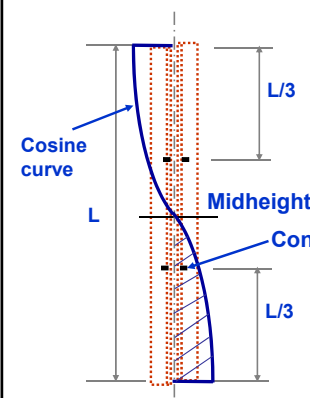

With 2 intermediate fasteners along the length of the column, connector "a" can only provide 13% of the shear transfer. The end connection must be designed for 87% of the total shear force.

YOU CANNOT DISTRIBUTE THE SHEAR CONNECTORS UNIFORMLY AS IN COMPOSITE BEAMS

68



COMPRESSION MEMBER DESIGN EXAMPLE 5

ANSI/AISC 360-10 Specification for the Design of Steel Buildings, 2010



69

COMPRESSION MEMBERS BUILT-UP COLUMNS

Design Slip Resistance – RCSC Specification for Structural Joints Using ASTM A325 and A490 Bolts

Example: 2L 5 x 3 1/4
 $P_u = 46.8k$ $F_y = 36 \text{ ksi}$ $L = 150 \text{ in.}$
 $A = 3.88 \text{ in.}$ $I_y = 5.53 \text{ in.}^4$ $\bar{x} = 0.648 \text{ in.}$
 Double Angles have 3/8 in. separation

$$Q = \frac{3.88}{2} \left(0.648 + \frac{0.375}{2} \right) = 1.62 \text{ in.}^3$$

$$\text{S.F.} = 0.008 (46.8)(150) \frac{1.62}{5.53} = 16.45k$$

The shear force (single shear) is 35% of P_u
 For a slip = 1/32 in. at the ends,
 the mid-height deflection will be 2 1/4 in.

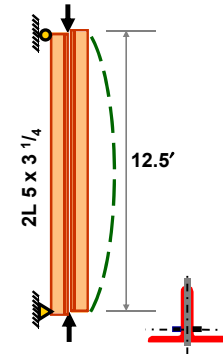

70

SUMMARY

- A better understanding of the stability design for various structural shapes has been provided.
- The design limit states of flexural, torsional, and flexural-torsional buckling resistance of compression members have been reviewed.
- The most frequently applied AISC LRFD and ASD design strengths for compression members provided in the Steel Specification have been discussed.
- The use of design examples and video demonstrations has helped our understanding of stability design.

71

POLLING QUESTION 2

72



Up Next...

Session 3: June 26 –
Behavior of Flexural Members
by R.D. Ziemian, PE, PhD

Using an approach similar to that employed in Session 1, this lecture will begin by presenting and dissecting the solution to the differential equation that defines the elastic lateral torsional buckling (LTB) strength of beams. Related flexural and torsional concepts, including the benefits of warping resistance, will be briefly reviewed. The assumption of elastic behavior will then be relaxed to define the inelastic LTB and plastic moment capacities of flexural members. The strength of beams without slender elements will be covered and ultimately presented in the form of beam resistance curves.

73

Individual Webinar Registrants

CEU/PDH Certificates

Within 2 business days...

- You will receive an email on how to report attendance from: registration@aisc.org.
- Be on the lookout: Check your spam filter! Check your junk folder!
- Completely fill out online form. Don't forget to check the boxes next to each attendee's name!



Individual Webinar Registrants

CEU/PDH Certificates

Within 2 business days...

- New reporting site (URL will be provided in the forthcoming email).
- Username: Same as AISC website username.
- Password: Same as AISC website password.



8-Session Registrants

CEU/PDH Certificates

One certificate will be issued at the conclusion of all 8 sessions.



8-Session Registrants

Access to the quiz: Information for accessing the quiz will be emailed to you by Wednesday. It will contain a link to access the quiz. EMAIL COMES FROM NIGHTSCHOOL@AISC.ORG

Quiz and Attendance records: Posted Tuesday mornings.
www.aisc.org/nightschool - click on Current Course Details.

Reasons for quiz:

- EEU – must take all quizzes and final to receive EEU
- CEUs/PDHS – If you watch a recorded session you must take quiz for CEUs/PDHS.
- REINFORCEMENT – Reinforce what you learned tonight. Get more out of the course.

NOTE: If you attend the live presentation, you do not have to take the quizzes to receive CEUs/PDHS.



8-Session Registrants

Access to the recording: Information for accessing the recording will be emailed to you by this Wednesday. The recording will be available for three weeks. For 8-session registrants only. EMAIL COMES FROM NIGHTSCHOOL@AISC.ORG.

CEUs/PDHS – If you watch a recorded session you must take AND PASS the quiz for CEUs/PDHS.



Night School Resources for 8-session package Registrants

Find all your handouts, quizzes and quiz scores, recording access, and attendance information all in one place!



Night School Resources for 8-session package Registrants

Go to www.aisc.org and sign in.



Login

If you're an existing customer, please enter your username and password.

USERNAME

Enter your username

PASSWORD

Enter your password

Remember Me

DON'T HAVE AN ACCOUNT?

My AISC allows you to access Engineering Journal articles and Design Guides you have downloaded from the bookstore.

[REGISTER NOW](#)



Night School Resources for 8-session package Registrants

Go to www.aisc.org and sign in.

IN THIS SECTION

- Edit Profile
- My Downloads
- My Pending Quizzes
- My Events
- Order History
- Course History
- Course Resources**

MyAISC

MY PROFILE
Update your contact and address information.
[EDIT PROFILE](#)

MY PURCHASED DOWNLOADS
Access articles and documents that you have purchased.
[VIEW DOWNLOADS](#)

MY COURSE RESOURCES
View online resources for Night School and Live Webinar package registrations.
[VIEW RESOURCES](#)

Night School Resources for 8-session package Registrants

Course Resources

Event	Start Date
NS 13 8-Session Package-Night School 13 - Design of Industrial Buildings	1/30/2017 7:00:00 PM
NS 14 8-Session Package-Night School 14 - Fundamentals of Stability	6/5/2017 7:00:00 PM

Night School Resources for 8-session package Registrants

Night School 13: Design of Industrial Buildings

8-SESSION PACKAGE RESOURCES

Event	Date	Handouts	Video	Quiz	Attendance
NS13 - Design Criteria	1/30/2017 7:00:00 PM	Handouts	Video Podcast: NS13DSN	Pass Score: 80	Pending
NS13 - Economic Considerations	2/6/2017 7:00:00 PM	Handouts	Available 02/08/2017 5pm EST	Available 02/08/2017 5pm EST	Pending
NS13 - Lateral Load Systems and Details	2/13/2017 7:00:00 PM	Handouts	Available 02/15/2017 5pm EST	Available 02/15/2017 5pm EST	Pending
NS13 - Preliminary Design Procedures	2/27/2017 7:00:00 PM	Handouts	Available 03/01/2017 5pm EST	Available 03/01/2017 5pm EST	Pending
NS13 - Crane Grid Design and Frame Analysis	3/6/2017 7:00:00 PM	Handouts	Available 03/08/2017 5pm EST	Available 03/08/2017 5pm EST	Pending
NS13 - Frame Member and Connection Design	3/13/2017 7:00:00 PM	Handouts	Available 03/15/2017 5pm EST	Available 03/15/2017 5pm EST	Pending
NS13 - Transfer Crane Grid & Longitudinal Bldg Bracing Dcn	3/27/2017 7:00:00 PM	Handouts	Available 03/28/2017 5pm EST	Available 03/28/2017 5pm EST	Pending
NS13 - Building Envelope and Bracing Design	4/3/2017 7:00:00 PM	Handouts	Available 04/05/2017 5pm EST	Available 04/05/2017 5pm EST	Pending
NS13 - Final Exam	4/10/2017 7:00:00 PM			Available 04/12/2017 5pm EST	

Night School Resources for 8-session package Registrants

- Weekly “quiz and recording” email.
- Weekly updates of the master Quiz and Attendance record found at www.aisc.org/nightschool. Scroll down to Quiz and Attendance records.
 - Updated on Tuesday mornings.

Night School Resources for 8-session package Registrants

- Webinar connection information:
 - Found in your registration confirmation/receipt.
 - Reminder email sent out Monday mornings.
- Link to handouts also found here.



There's always a solution in steel.

Thank You

Please give us your feedback!
Survey at conclusion of webinar.



87

**TORSIONAL BUCKLING
 CRUCIFORM MEMBERS**

$$\bar{r}_o^2 = x_o^2 + y_o^2 + \frac{I_x + I_y}{A_g} \quad (E4 - 11)$$

$$F_{crz} = \frac{GJ}{A_g \bar{r}_o^2} \quad (E4 - 3)$$

88



**TORSIONAL BUCKLING
CRUCIFORM MEMBERS**

Twist about the shear center of the section.

89

**TORSIONAL BUCKLING
CRUCIFORM MEMBERS**

$$J = \frac{4bt^3}{3}$$

$$I_x = I_y = 2 \frac{b^3t}{3}$$

$$F_{crz} = \frac{GJ}{Ar_c^2} = \frac{GJ}{I_x + I_y} = \frac{G}{\left(\frac{b}{t}\right)^2} = \frac{0.385E}{\left(\frac{b}{t}\right)^2}$$

90

**DESIGN STRENGTH
SINGLE ANGLE COLUMN L 2 x 2 x 3/16**

Buckling about z-axis

$$\left(\frac{KL}{r}\right)_z = \frac{44}{0.389} = 113 \leq 4.71 \sqrt{\frac{E}{F_y}} = 133 \quad F_y = 36 \text{ ksi}$$

$$F_c = \frac{\pi^2 E}{\left(\frac{KL}{r}\right)^2} = 22.41 \text{ ksi}$$

$$F_{cr} = \left[0.658 \frac{F_y}{F_c}\right] F_y = 18.38 \text{ ksi}$$

$$P_n = F_{cr} A_g = 13.27 \text{ kips}$$

$$\text{ASD } \frac{P_n}{\Omega} = 7.95 \text{ kips} \quad \text{LRFD } \phi P_n = 11.94 \text{ kips}$$

Buckling about z-axis does not control

91

**COMPRESSION MEMBER
DESIGN EXAMPLE 4**

*ANSI/AISC 360-10 Specification
for the Design of Steel Buildings, 2010*

92

MEMBER DESIGN STRENGTH
SINGLE ANGLE COLUMN L 6 x 6 x 5/8

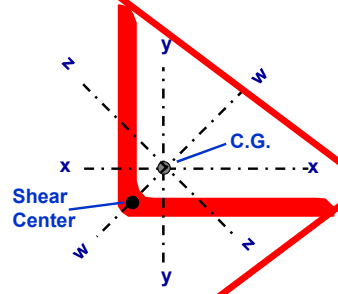

Section Properties:
 $A_g = 7.13 \text{ in.}^2$
 $I_x = I_y = 24.1 \text{ in.}^4$
 $J = 0.955 \text{ in.}^4$
 $C_w = 2.5 \text{ in.}^6$
 $r_x = 1.84 \text{ in.}$
 $r_y = 1.17 \text{ in.}$
 $\bar{r}_o = 3.28 \text{ in.}$
 $Q = 1.0$
 $H = 0.631$

Material Properties:
 $F_y = 50 \text{ ksi}$
 $E = 29,000 \text{ ksi}$
 $G = 0.385 E$

Length: $KL = L = 10 \text{ ft.}$

93

MEMBER DESIGN STRENGTH
SINGLE ANGLE COLUMN L 6 x 6 x 5/8

Flexural-Torsional Buckling

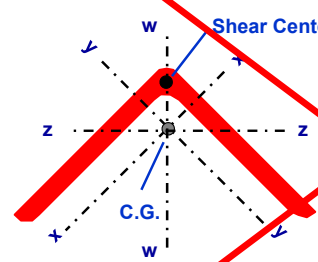

$I_z = A_g r_z^2 = (7.13)(1.17)^2 = 9.76 \text{ in.}^2$

$I_w = I_x + I_y - I_z$
 $= 2(24.1) - 9.76 = 38.44 \text{ in.}^4$

$r_w = \sqrt{\frac{I_w}{A_g}} = \sqrt{\frac{38.44}{7.13}} = 2.32 \text{ in.}$

94

MEMBER DESIGN STRENGTH
SINGLE ANGLE COLUMN L 6 x 6 x 5/8

Flexural-Torsional Buckling

$$F_{ez} = \left(\frac{\pi^2 EC_w}{(KL)^2} + GJ \right) \frac{1}{A_g \bar{r}_o^2} \approx \frac{GJ}{A_g \bar{r}_o^2}$$

Small compared to GJ , therefore this term can be safely ignored for angles, double angles and tees
 In this case, 50 versus 10700

$$F_{ez} = \frac{GJ}{A_g \bar{r}_o^2} = \frac{(11200)(0.955)}{(7.13)(3.28)^2} = 139.44 \text{ ksi}$$

95

MEMBER DESIGN STRENGTH
SINGLE ANGLE COLUMN L 6 x 6 x 5/8

Flexural-Torsional Buckling

$$F_{ew} = \frac{\pi^2 E}{\left(\frac{KL}{r_w} \right)^2} = 106.98 \text{ ksi}$$

$$F_e = \frac{F_{ew} + F_{ez}}{2H} \left[1 - \sqrt{1 - \frac{4F_{ew}F_{ez}H}{(F_{ew} + F_{ez})^2}} \right] \quad (E4 - 5)$$

$$F_e = \frac{106.98 + 139.44}{2(0.631)} \left[1 - \sqrt{1 - \frac{4(106.98)(139.44)(0.631)}{(106.98 + 139.44)^2}} \right]$$

$F_e = 74.90 \text{ ksi}$

96



DESIGN STRENGTH
SINGLE ANGLE COLUMN L 6 x 6 x 5/8
Buckling about z-axis

$$\left(\frac{KL}{r}\right)_z = \frac{(12)(10)}{1.17} = 103 \leq 4.71 \sqrt{\frac{E}{F_y}} = 113 \quad \text{OK}$$

$$F_e = \frac{\pi^2 E}{\left(\frac{KL}{r}\right)_z^2} = 27.21 \text{ ksi} \quad \frac{F_y}{F_{ez}} = \frac{50}{27.21} = 1.837$$

$$F_{cr} = \left[0.658 \frac{F_y}{F_e} \right] F_y = 23.18 \text{ ksi} \quad \text{(E3 - 2)}$$

$$P_n = F_{cr} A_g = 165.25 \text{ kips} \quad \text{(E3 - 1)}$$

→ ASD $\frac{P_n}{\Omega} = 98.95 \text{ kips}$ LRFD $\phi P_n = 148.72 \text{ kips}$

97

MEMBER DESIGN STRENGTH
SINGLE ANGLE COLUMN L 6 x 6 x 5/8
Flexural-Torsional Buckling

$$\left(\frac{KL}{r}\right)_{F-T} = \frac{(12)(10)}{2.32} = 52 \leq 4.71 \sqrt{\frac{E}{F_y}} = 113 \quad \text{OK}$$

$$\frac{F_y}{F_{eF-T}} = \frac{50}{74.90} = 0.667$$

$$F_{crF-T} = \left[0.658 \frac{F_y}{F_e} \right] F_y = 37.82 \text{ ksi}$$

$$P_n = F_{cr} A_g = 269.66 \text{ kips}$$

ASD $\frac{P_n}{\Omega} = 161.47 \text{ kips}$ LRFD $\phi P_n = 242.69 \text{ kips}$

Buckling about z-axis controls

98

COMPRESSION MEMBERS
BUILT-UP COLUMNS

Star-Batten
Column Detail

Built-up Columns, Closely Spaced Members

99

POLLING QUESTION 1

The AISC 360-10 Specification defines which buckling limit states for compression members?

- A. Flexural and Local Plate
- B. Torsional and Flexural-Torsional
- C. Flexural and Distortional

100