



AISC Night School

Thank you for joining our live webinar today.
We will begin shortly. Please standby.

Thank you.

Need Help?
Call ReadyTalk Support: 800.843.9166





Today's audio will be broadcast through the internet.

Alternatively, to hear the audio through the phone, dial 888 504 7949. Passcode: 660099.





Today's live webinar will begin shortly.

Please stand by.

As a reminder, all lines have been muted. Please type any questions or comments through the Chat feature on the left portion of your screen.

Today's audio will be broadcast through the internet.

Alternatively, to hear the audio through the phone, dial 888-504-7949. Passcode: 660099.





AISC is a Registered Provider with The American Institute of Architects Continuing Education Systems (AIA/CES). Credit(s) earned on completion of this program will be reported to AIA/CES for AIA members. Certificates of Completion for both AIA members and non-AIA members are available upon request.

This program is registered with AIA/CES for continuing professional education. As such, it does not include content that may be deemed or construed to be an approval or endorsement by the AIA of any material of construction or any method or manner of handling, using, distributing, or dealing in any material or product.

Questions related to specific materials, methods, and services will be addressed at the conclusion of this presentation.





Copyright Materials

This presentation is protected by US and International Copyright laws. Reproduction, distribution, display and use of the presentation without written permission of AISC is prohibited.

© The American Institute of Steel Construction 2017





Course Description

August 7, 2017– Design of Bracing for Beams

This lecture will emphasize the design requirements for bracing of beam systems. Several design examples will demonstrate the effective use of the AISC Specification Appendix 6 provisions. These examples will include relative, nodal, and lean-on applications. The uses of the provisions covered in the Specification Appendix as well as modifications covered in the Specification Commentary will be addressed. The importance of brace connection details is emphasized.





Learning Objectives

- Learn and understand the design requirements related to bracing beams.
- Gain an understanding of AISC Specification Appendix 6 requirements.
- Become familiar with designing for relative, nodal, and lean-on bracing applications.
- Understand bracing design through the use of design examples.



There's always a solution in steel.



Fundamentals of Stability for Steel Design

Session 8: Design of Bracing for Beams

August 7, 2017



Presented by
Joseph A. Yura, Ph.D., P.E.
Emeritus Professor
University of Texas at Austin

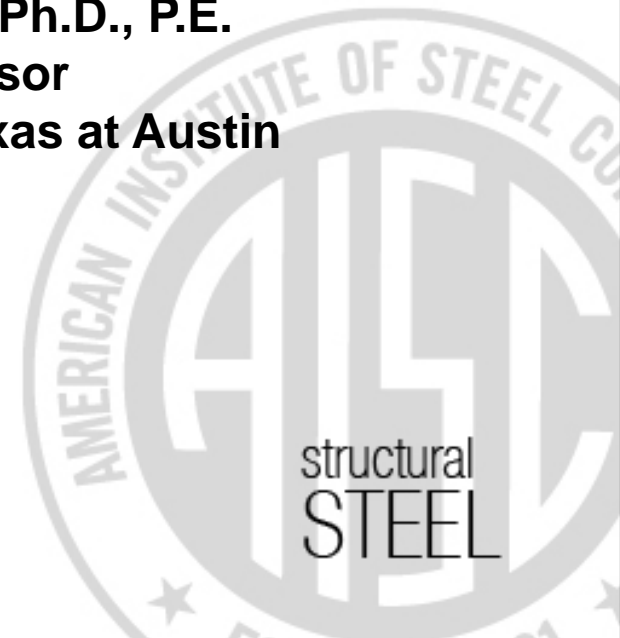

There's always a solution in steel.

Fundamentals of Stability for Steel Design

Session 8

Design of Bracing for Beams

Joseph A. Yura, Ph.D., P.E.



BEAM BRACING

- Multiple girder systems
 - System buckling of narrow girder units
 - Lean-on bracing

- Bracing of single girders
 - Lateral brace behavior and design
 - Torsional brace behavior and design

- Multiple girder systems
 - **System buckling of narrow girder units**

TWIN GIRDER SYSTEMS - Plan View

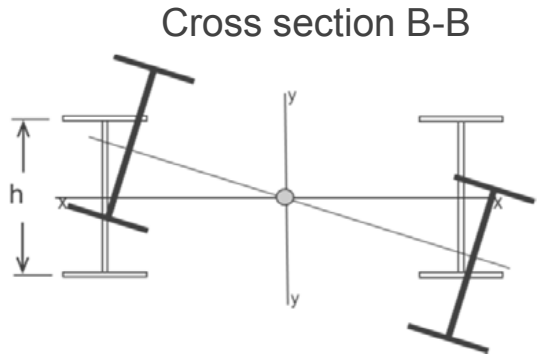
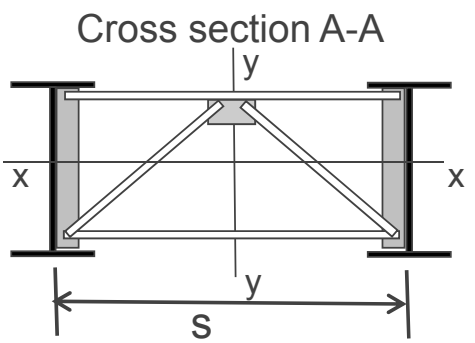
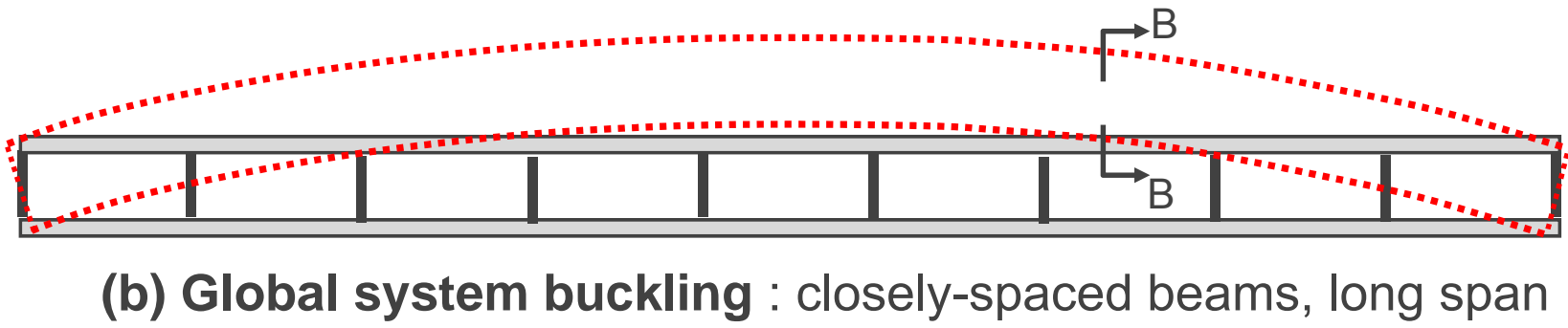
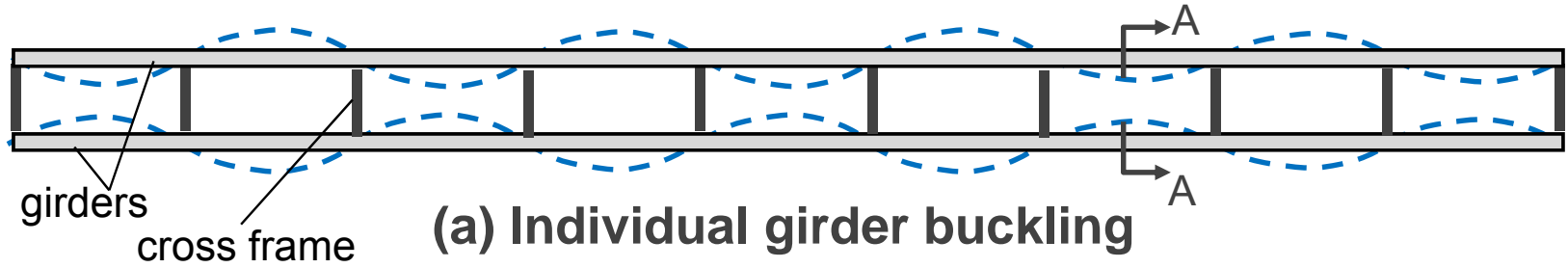

SYSTEM TWIST

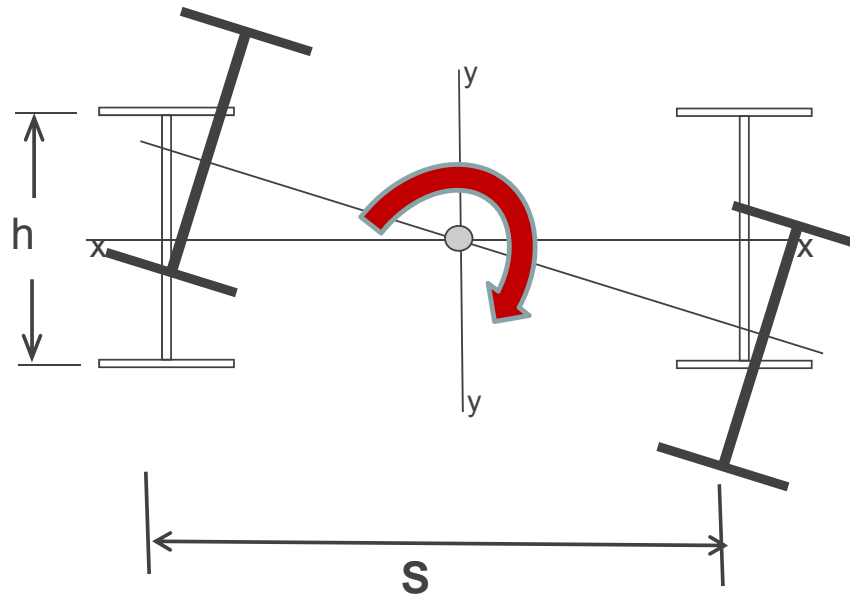

$$\text{Total warping rigidity} = 2E \left(\frac{h^2}{4} I_y + \frac{s^2}{4} I_x \right)$$

Use with beam buckling formulas in Lectures 3 and 4

TWIN GIRDER SYSTEM BUCKLING

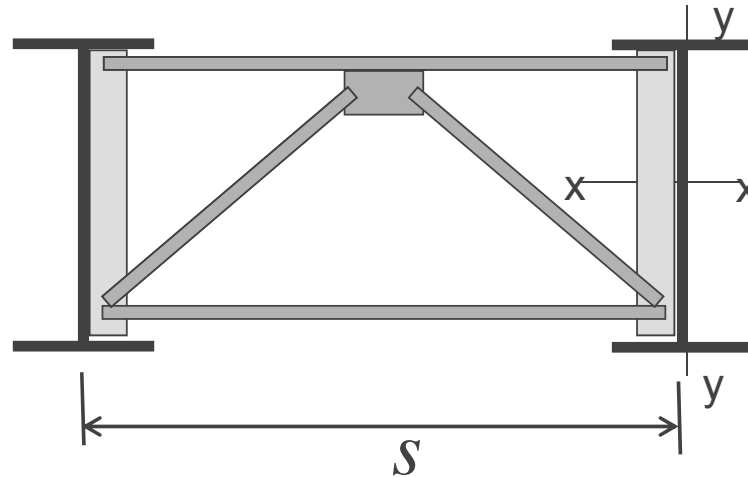

$$M_{crs} = \frac{2\pi}{L} \sqrt{EI_y GJ + \frac{\pi^2 E^2 I_y (I_y h^2 + I_x s^2)}{4L^2}} \quad (\text{exact})$$

All section properties are for a single girder

$$\Sigma \text{ Girder Maximum Moments} \leq M_{crs}$$

TWIN GIRDER SYSTEM BUCKLING

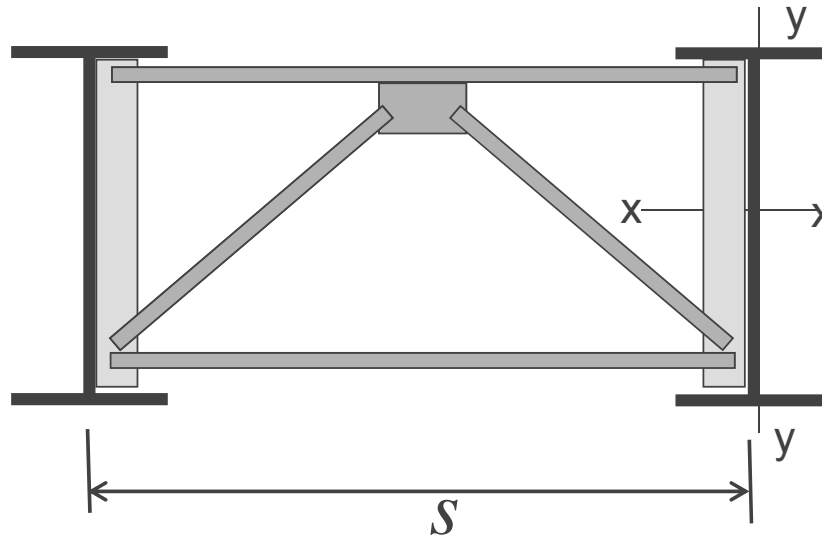

$$M_{crs} = \frac{2\pi}{L} \sqrt{\cancel{EI_y GJ} + \frac{\pi^2 E^2 I_y (\cancel{I_y k^2} + I_x s^2)}{4L^2}} \quad (\text{exact})$$

$$M_{crs} = \frac{\pi^2 s E}{L^2} \sqrt{I_y I_x} \quad (\text{simple})$$

TWIN GIRDER EXAMPLE

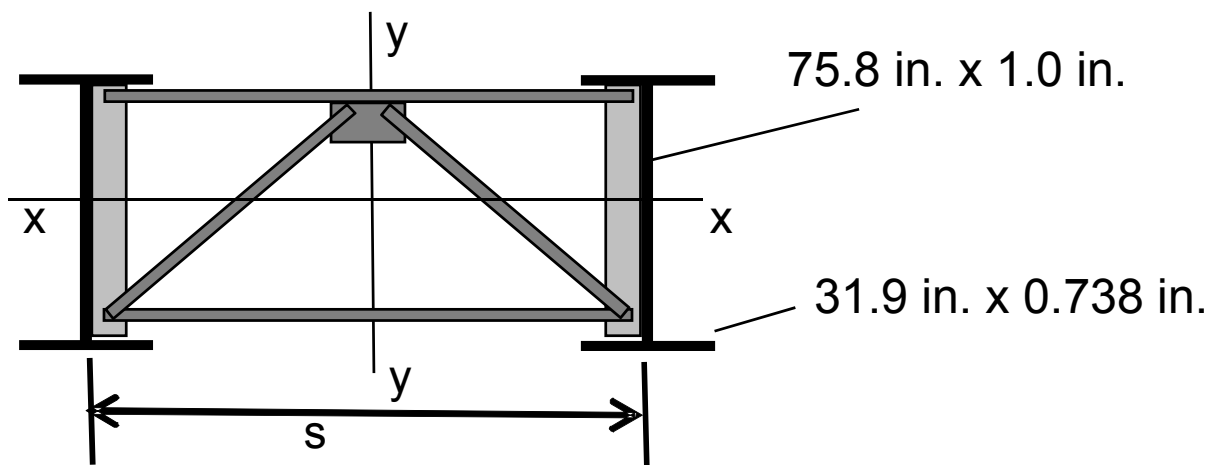

L = 170 ft

System Buckling Stress (ksi)			
Analysis Type	Girder Spacing S (in.)		
	80	109	150
FEA	21.31	28.56	38.68
Exact	21.40	28.73	39.21
Simple	20.70	28.22	38.83

16



More Info on Global Buckling



Improved capacity



Similar to Lecture 2



Yura et al,(2008) "Global Lateral Buckling of I-Shaped Girder Systems", *J. Struct. Engrg.*, ASCE, Vol. 134, No. 9, pp. 1487-1494

17

- Multiple girder systems
 - **Lean-on bracing**

LEAN-ON LATERAL BRACING

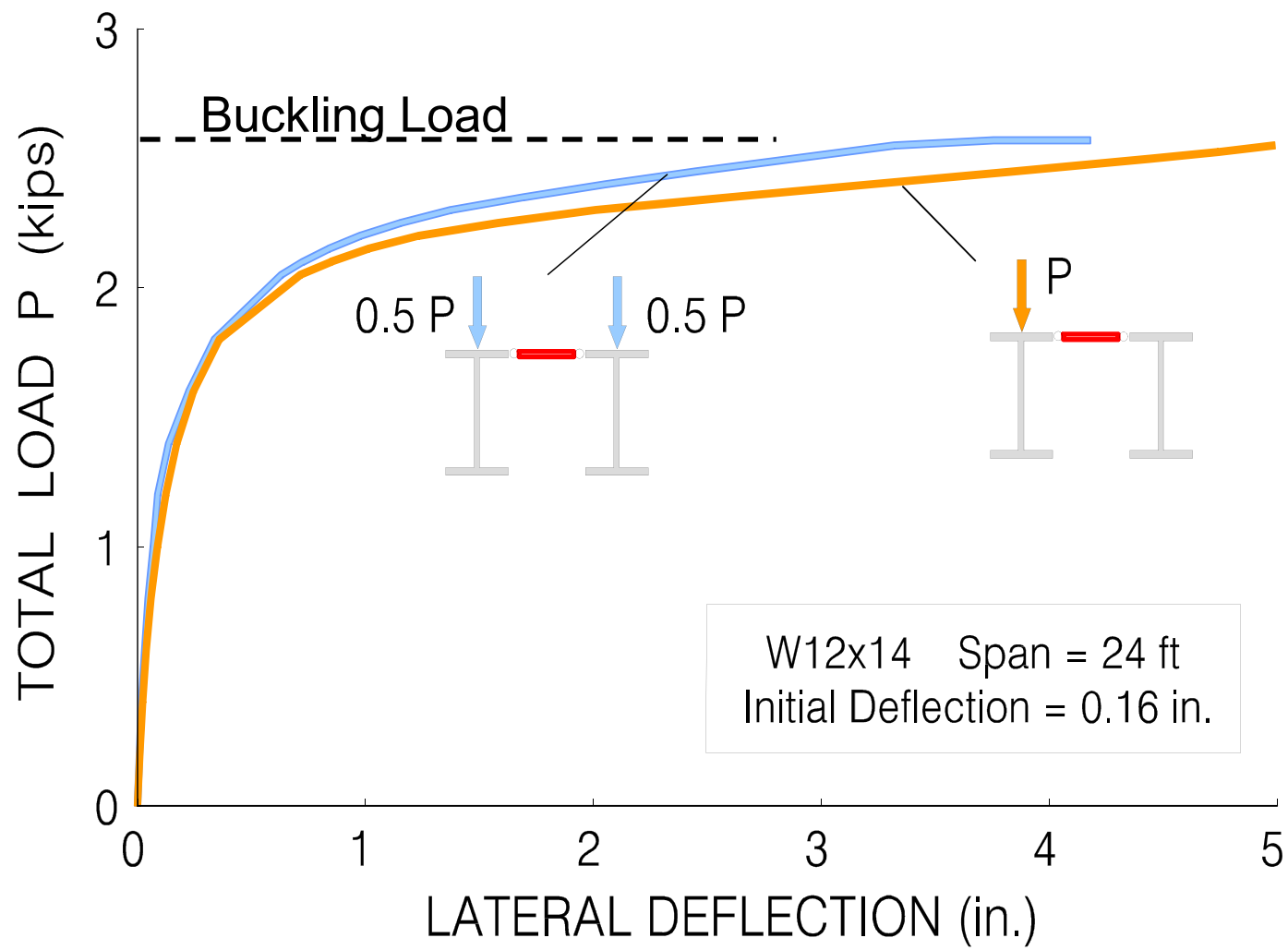

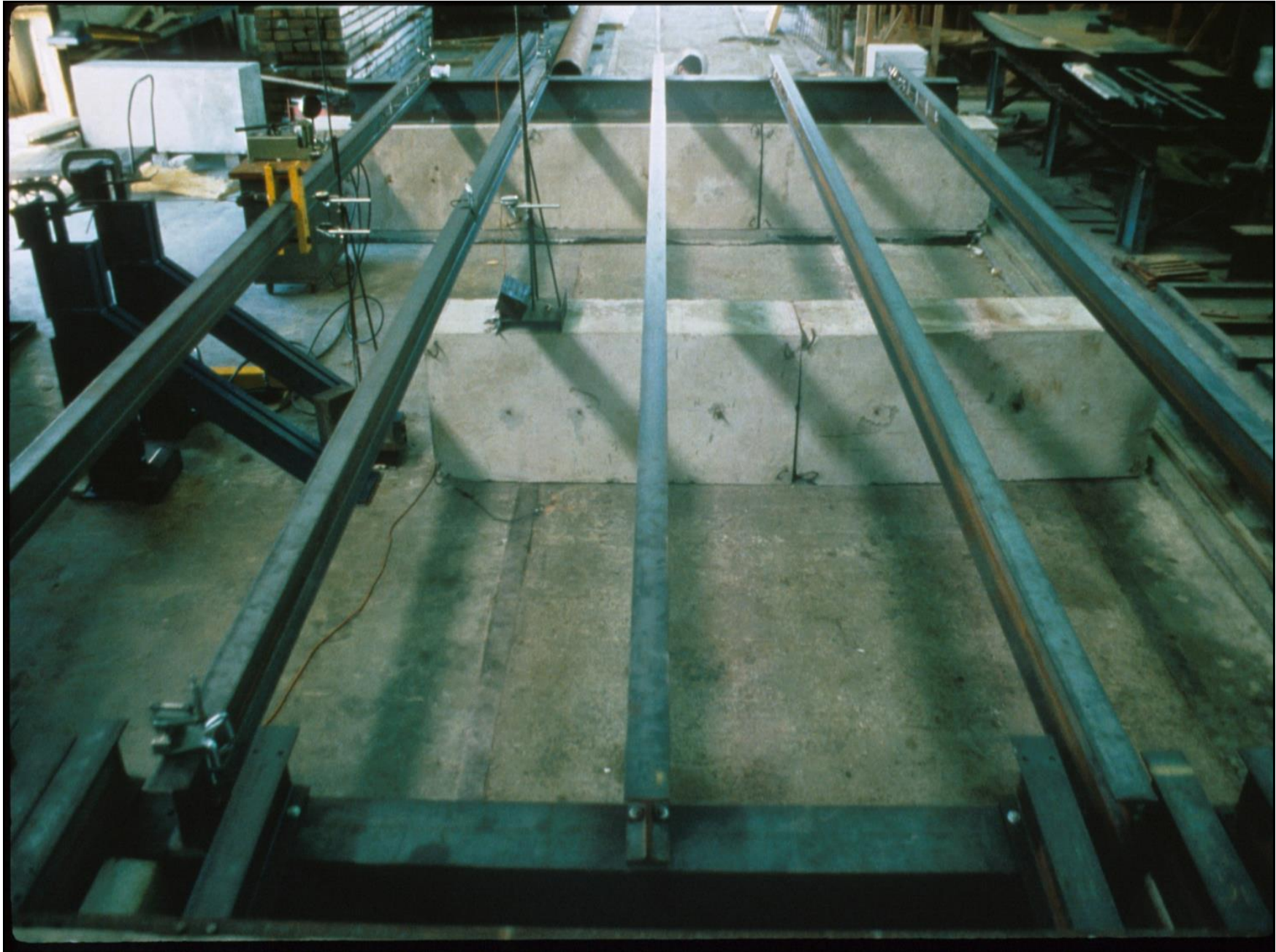



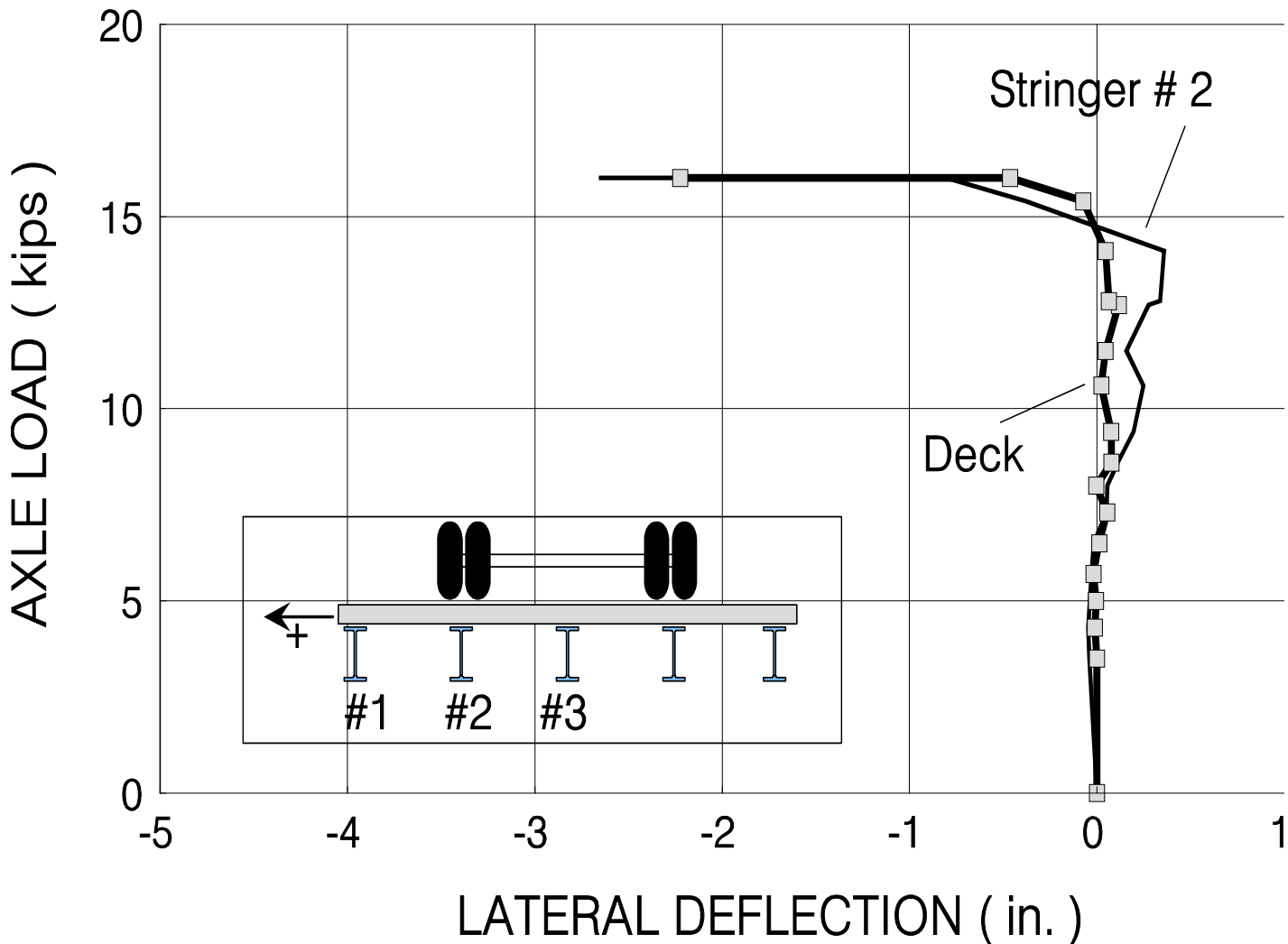

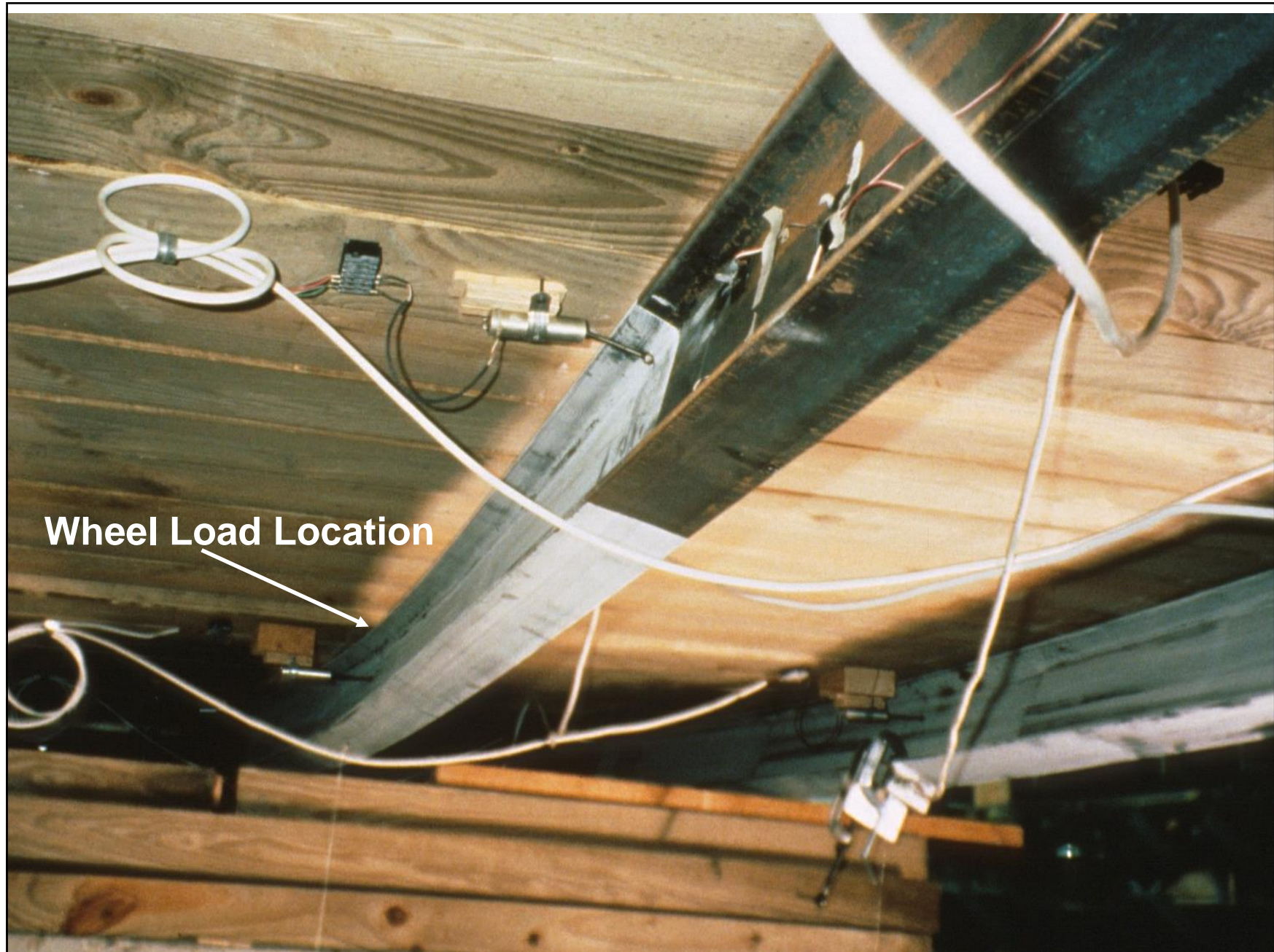

Wheel Load Location

LEAN-ON BEAM SYSTEMS

- Beams that are interconnected by members without torsional restraint lateral-torsional buckle as a system :

$$\Sigma M_r \leq \Sigma M_{cr}$$

M_r = maximum moment in an individual beam

M_{cr} = lateral-torsional buckling capacity of an individual beam
assuming that the interconnection points are not brace points

- Check individual beams for buckling between the intersection points treated as brace points

- Bracing of single girders
 - Lateral brace behavior and design
 - Torsional brace behavior and design

BEAM BRACING

A successful bracing system prevents twist of the cross section

LATERAL BRACING of the compression flange will prevent twist since the tension flange would prefer to remain straight for simply-supported beams. For beams with inflection points both flanges must be laterally braced to prevent twist.

TORSIONAL BRACING prevents twist of the cross section at the brace location. The brace does not need to prevent lateral movement of the cross section to be successful.

An inflection point is not a brace point. Twist of the cross section is not prevented at the inflection point.

Bracing must have sufficient stiffness and strength

TYPES OF BEAM BRACING

LATERAL BRACING

- * *RELATIVE*
- * *DISCRETE (NODAL)*
- ~~* *CONTINUOUS*~~
- * *LEAN - ON*

TORSIONAL BRACING

- * *DISCRETE (NODAL)*
- * *CONTINUOUS*

- Bracing of single girders
 - **Lateral brace behavior and design**

LATERAL BRACING SYSTEMS

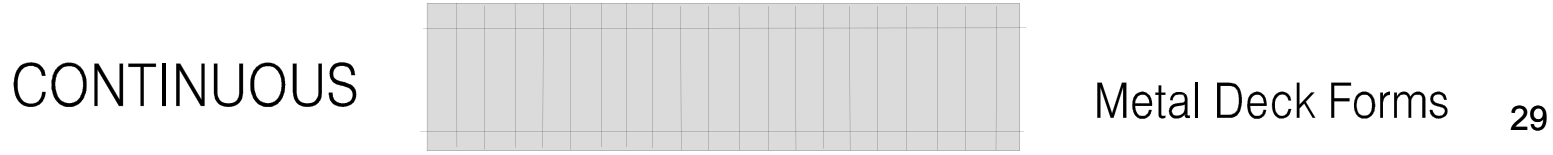
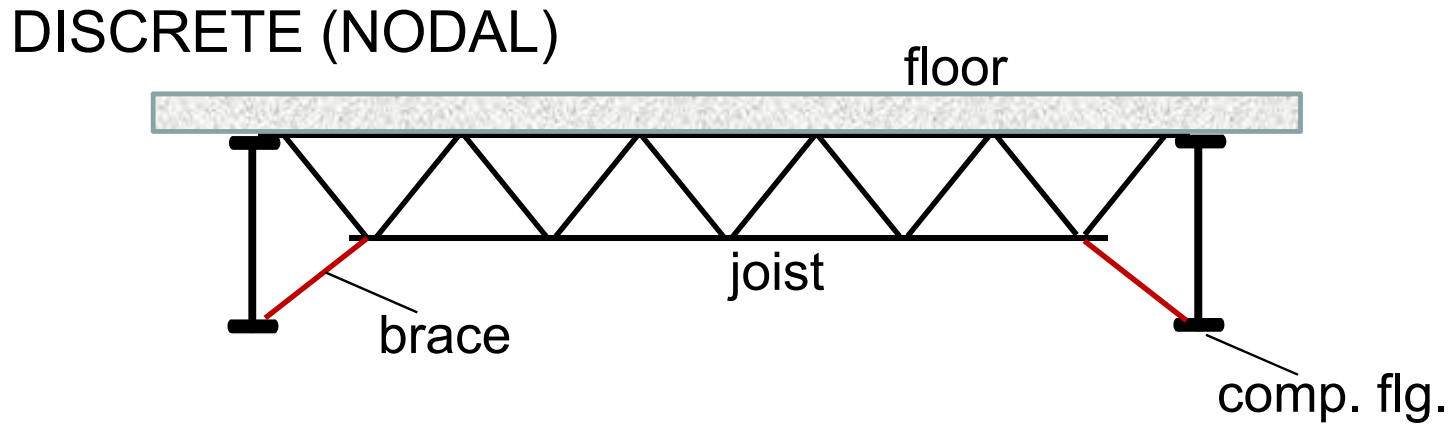
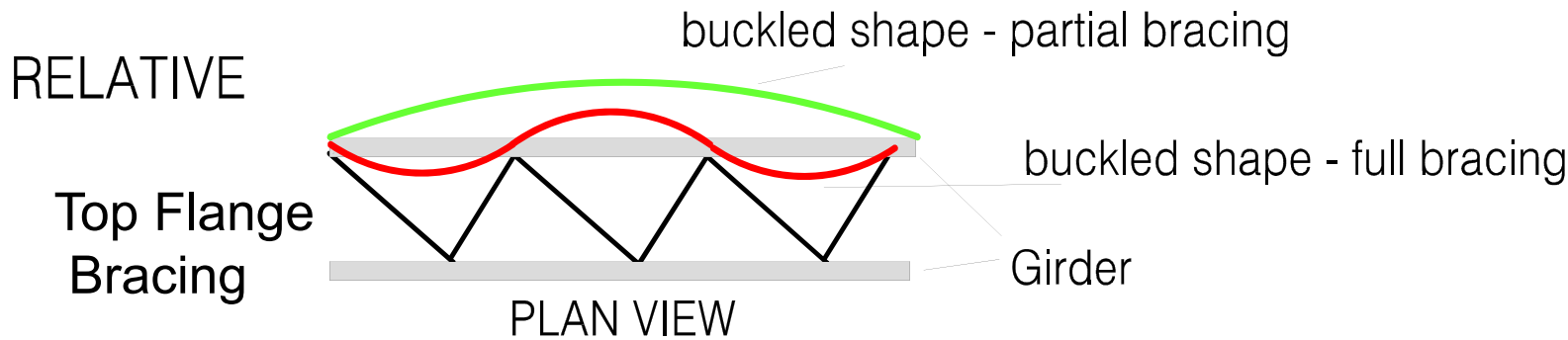

FACTORS THAT AFFECT BRACE EFFECTIVENESS

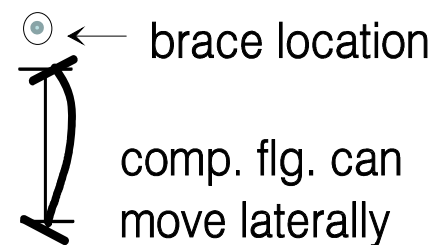
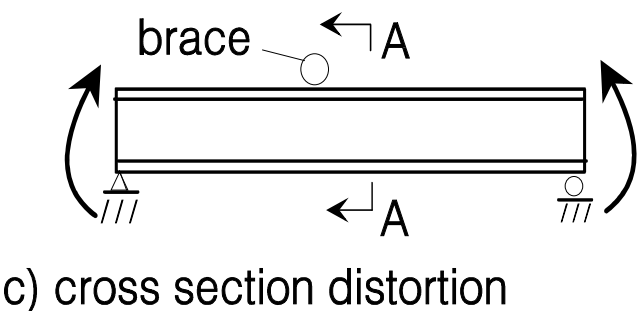
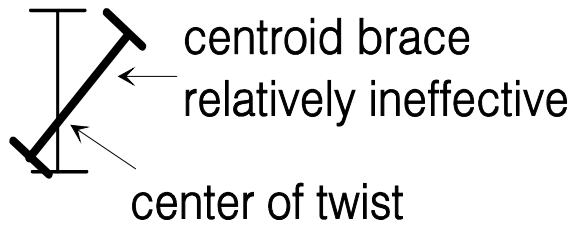
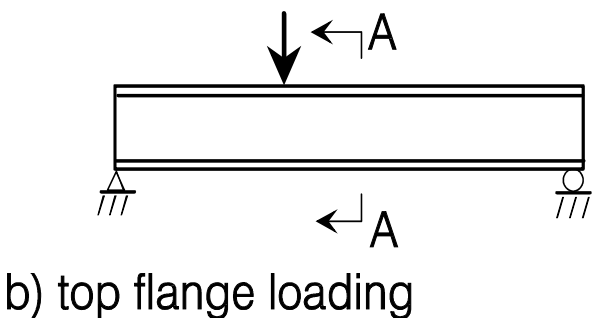
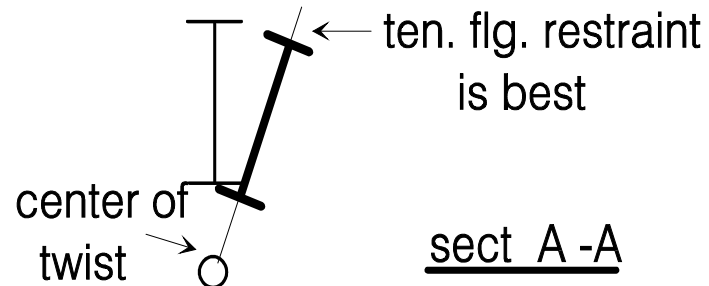
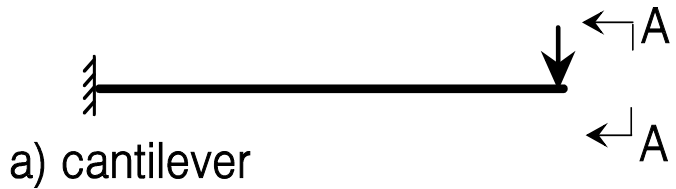

EFFECT OF LOAD AND BRACE POSITION

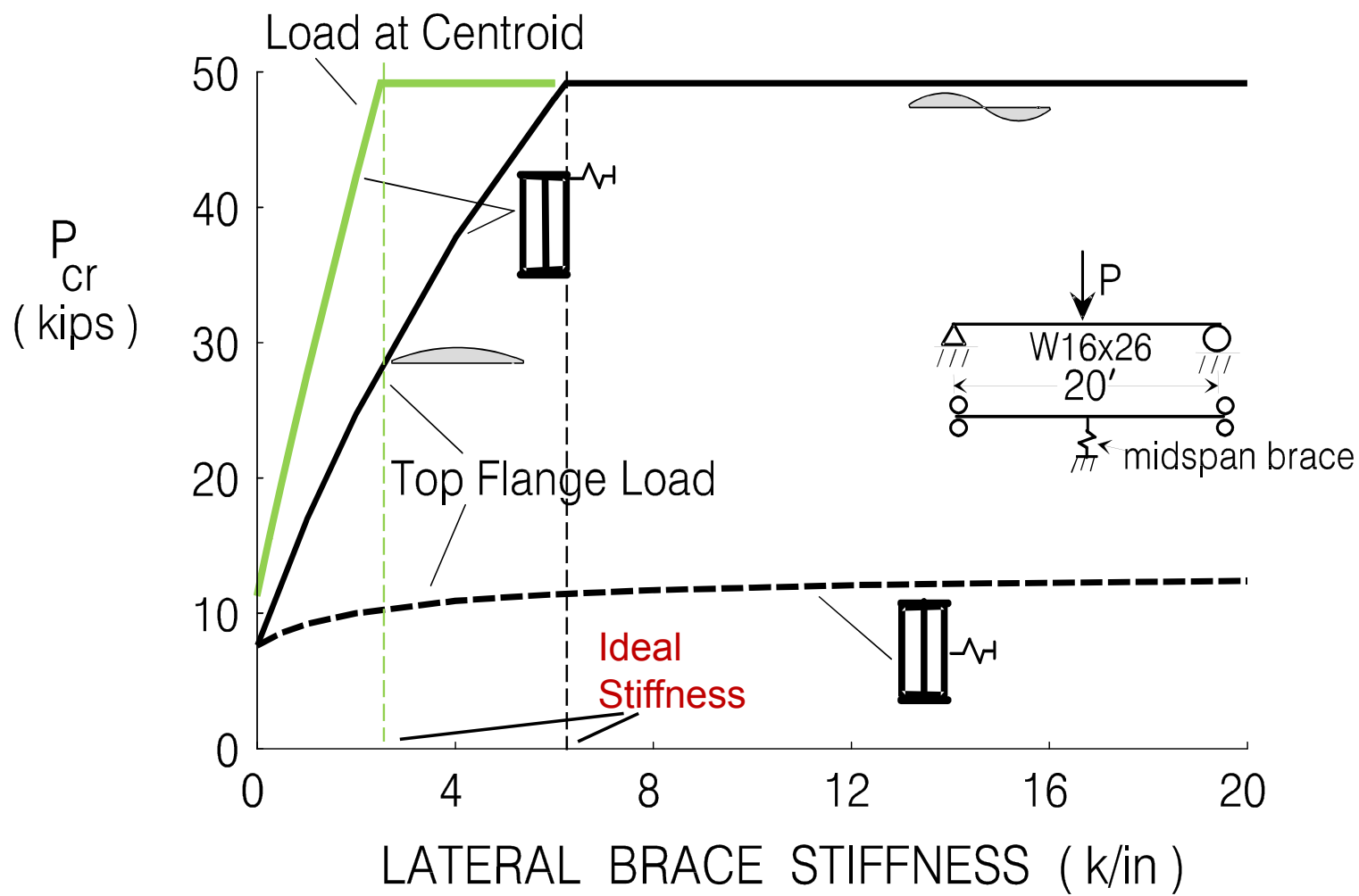

BEAMS WITH INFLECTION POINTS

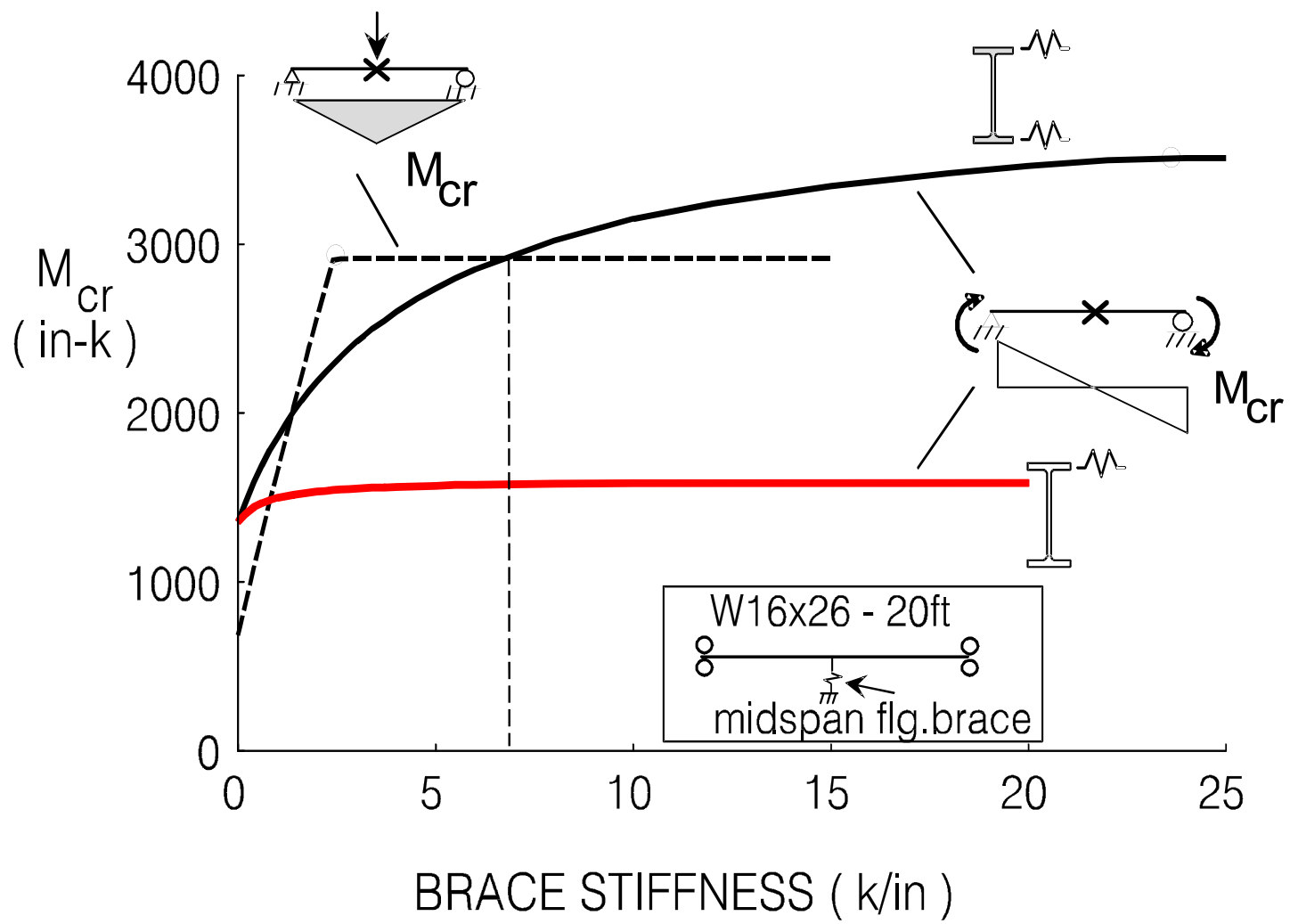

LATERAL BRACING TESTS

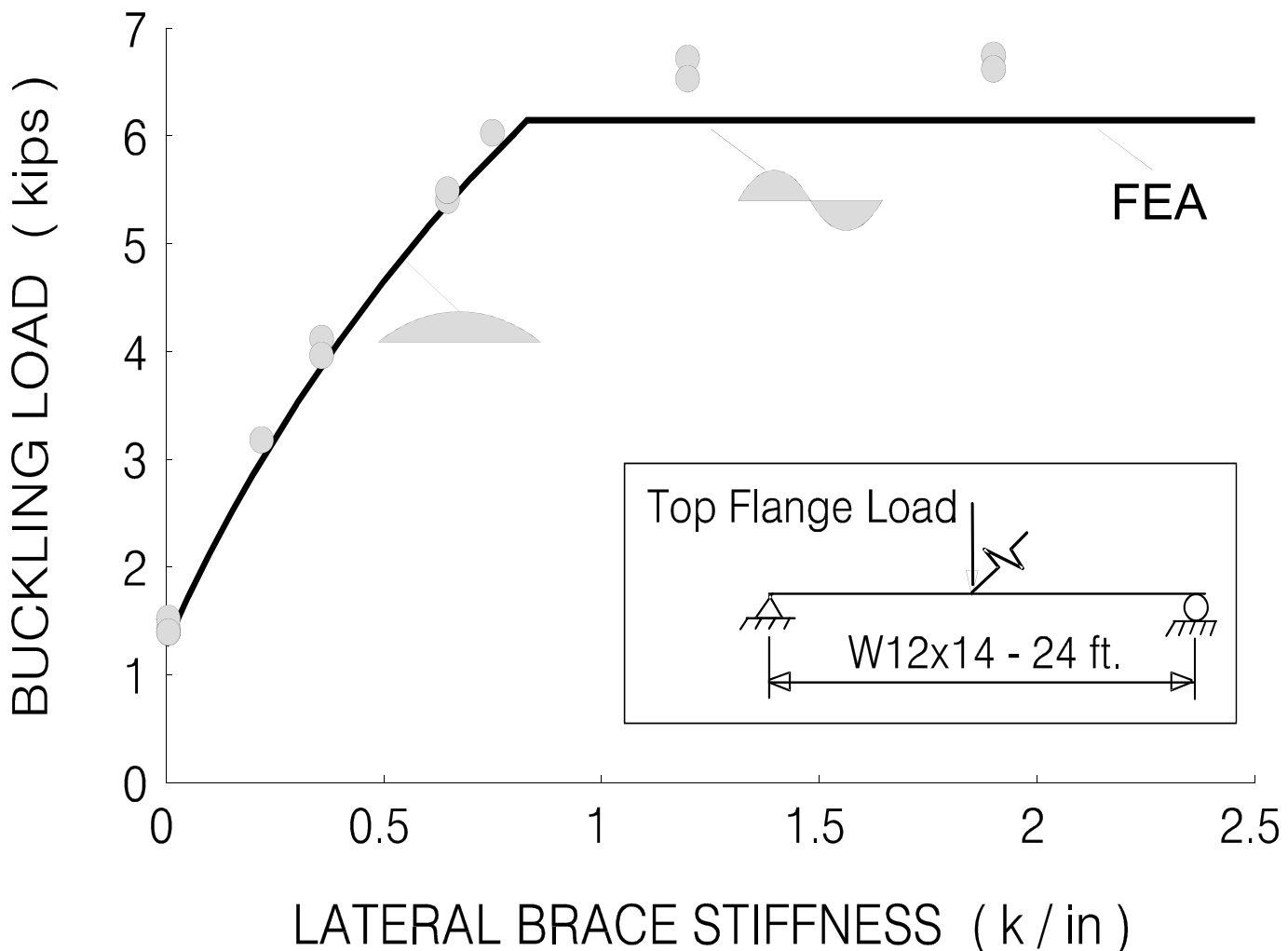

LATERAL BRACING DESIGN FACTORS

- NUMBER OF BRACES
- BRACE POSITION
 - Place at or near the flange
 - Top and bottom braces needed for compression on both flanges
- LOAD POSITION
 - Top flange loading is the worst
- MOMENT DIAGRAM
 - Consider the C_b modification factor

34



WINTER'S APPROACH FOR BEAM BRACING

PLAN VIEW

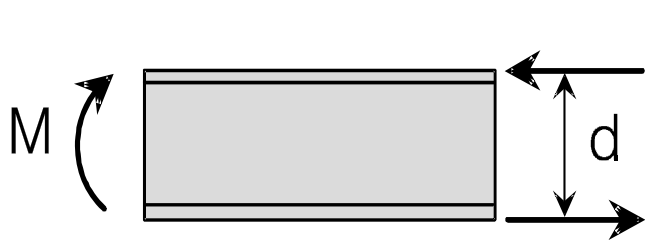
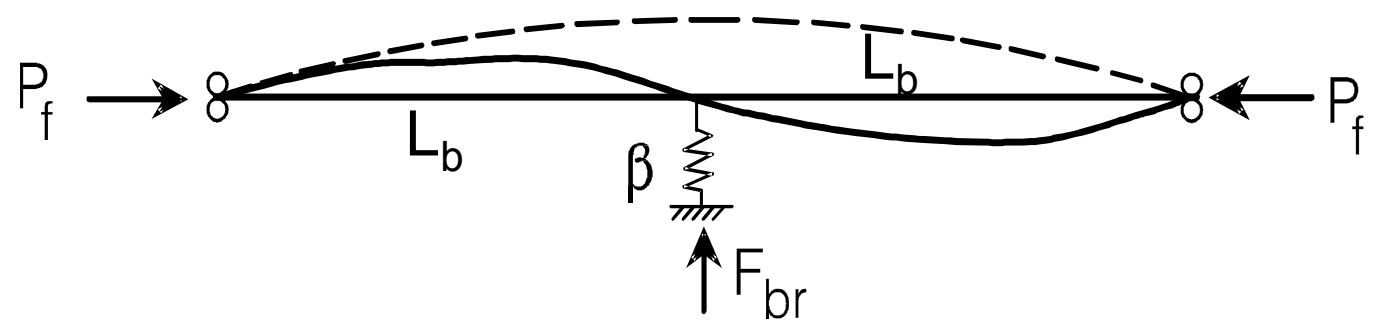

$$P_f = \pi^2 E I_{yc} / L_b^2$$

$$\beta_i = \frac{2P_f}{L_b}$$

SINGLY - SYMMETRIC SECTIONS

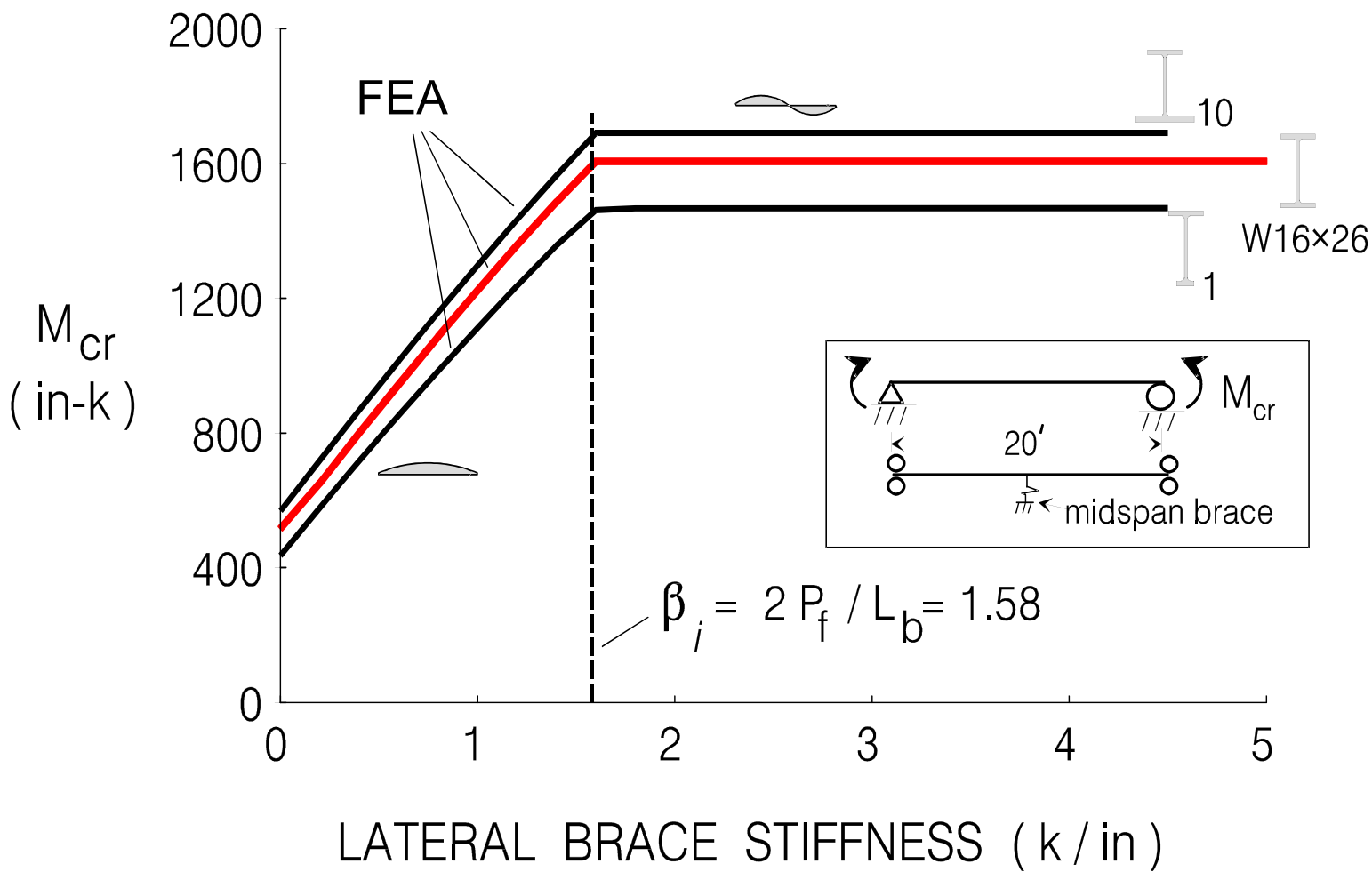

LATERAL BRACING REQUIREMENTS - FULL BRACING

STIFFNESS:

$$\beta_L^* = 2 N_i P_f C_{bb} C_L C_d / L_b$$

From Lecture 7

1.0 - relative bracing

4 - (2/n) discrete bracing

$$\pi^2 E I_{yc} / L_b^2$$

$$1 + (1.2 / n)$$

$$1 + (M_s / M_l)^2$$

double curv



LATERAL BRACING REQUIREMENTS - FULL BRACING

STIFFNESS:

$$\beta_L^* = 2 N_i P_f C_{bb} C_L C_d / L_b$$

From Lecture 7

1.0 - relative bracing

4 - (2/n) discrete bracing

$$\pi^2 E I_{yc} / L_b^2$$

$$1 + (1.2 / n)$$

$$1 + (M_s / M_l)^2$$

double curv

Another practical option for the compressive force

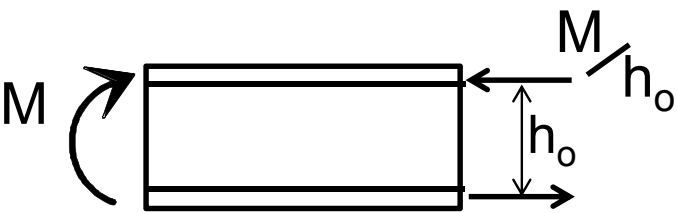

APPROXIMATE COMPRESSIVE FLANGE FORCE

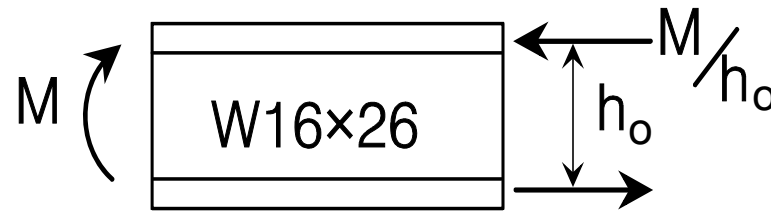

L_b	M_{cr}	$P_f = \pi^2 E I_{yc} / L_b^2$	M / h_o	$\frac{M / h_o}{P_f}$
ft	k-in	kips	kips	
5	6035	381	393	1.03
10	1640	95.3	107	1.12
15	817	42.4	53.3	1.26

39

SIMPLIFIED BRACING REQUIREMENTS

STIFFNESS : $\beta_L^* = 2 N_i \left[P_f C_{bb} \frac{M/h_o}{C_L C_d} \right] / L_b$

4 - (2/n) discrete bracing

1 + (1.2/n)
 top flg loading

n	1	2	3	4	5	6
2 N _i C _L	8.8	9.6	9.3	9.1	8.9	8.8

say 10



LATERAL BRACING – LRFD RECOMMENDATIONS

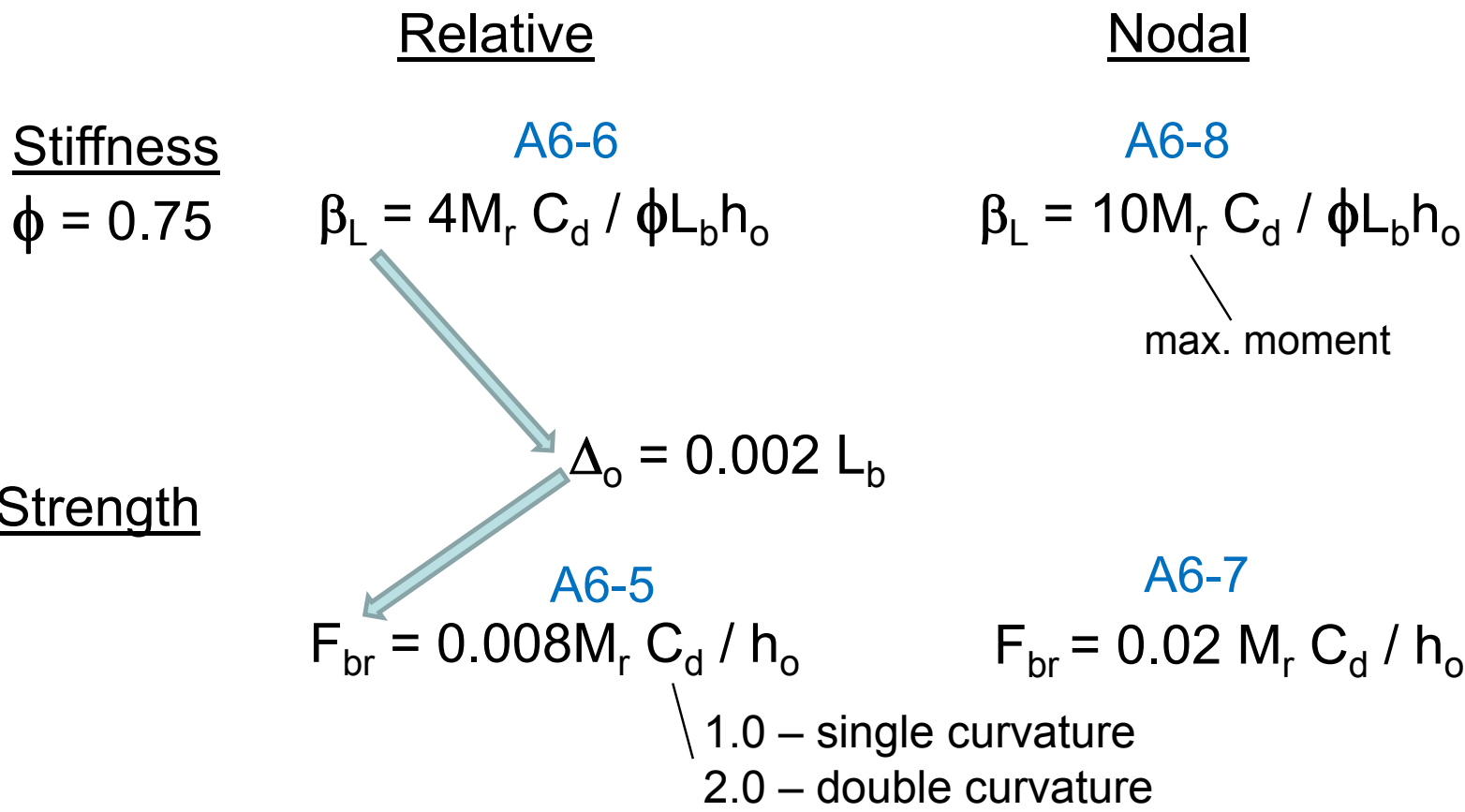

Note: The required bracing spacing, L_q , can be substituted for the actual spacing, L_b .



DISCRETE BEAM BRACING - Gravity plus Uplift Wind

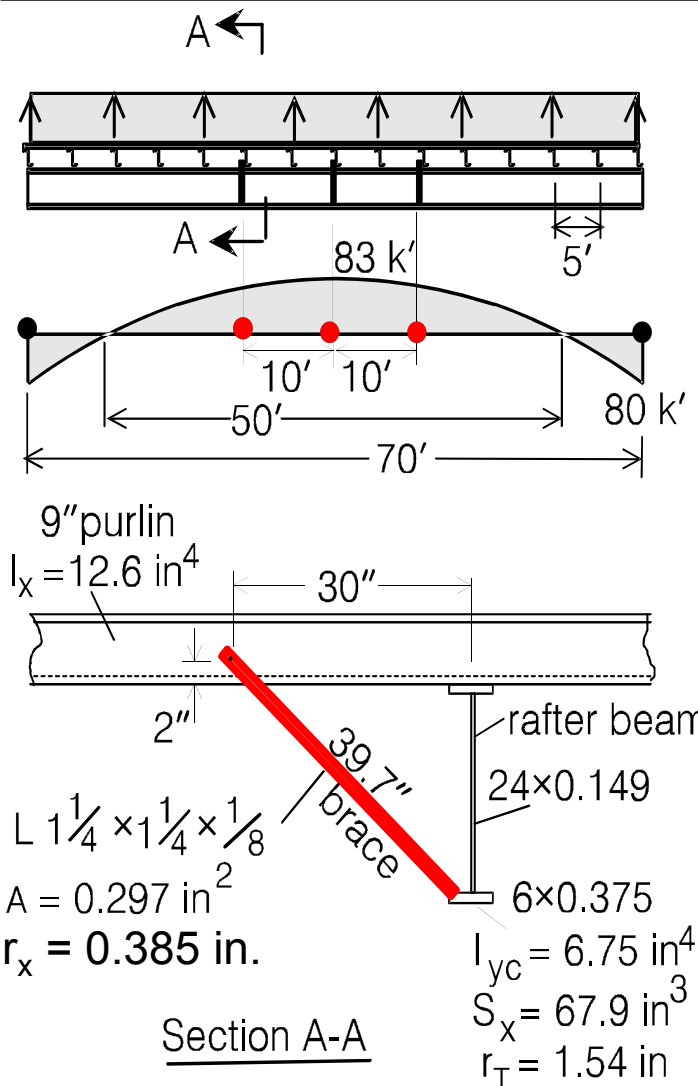

The rafter of an industrial building frame is braced along the top flange by purlins spaced at 5 ft interval. The uplift load condition produces compression on the bottom flange and three angle braces are proposed to stabilize the rafter. Check the detail shown. $F_y = 50$ ksi.

From **F5-4** for LTB of the rafter
at 83 k' with $C_b = 1.0$.

$$83 \times 12 = 0.9(67.9)(1.0) \frac{\pi^2(29000)(1.54)^2}{L_q^2}$$

$$L_q = 17.0'$$



DISCRETE BEAM BRACING - Gravity plus Uplift Wind

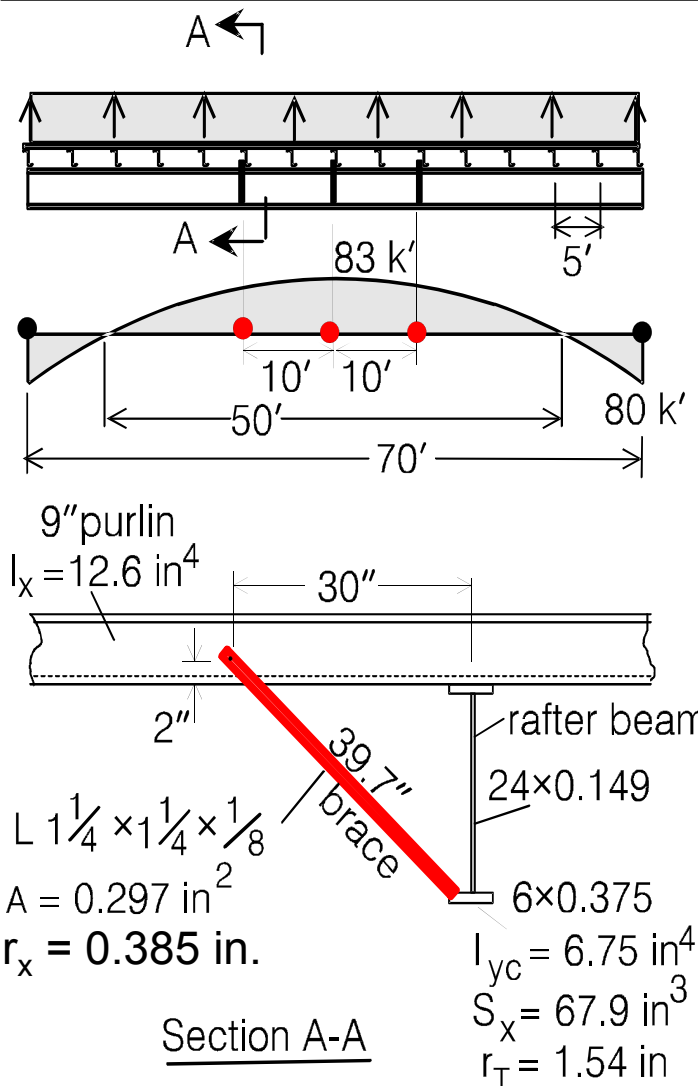

The rafter of an industrial building frame is braced along the top flange by purlins spaced at 5 ft interval. The uplift load condition produces compression on the bottom flange and three angle braces are proposed to stabilize the rafter. Check the detail shown. $F_y = 50$ ksi.

From **F5-4** for LTB of the rafter
at 83 k' with $C_b = 1.0$.

$$83 \times 12 = 0.9(67.9)(1.0) \frac{\pi^2(29000)(1.54)^2}{L_q^2}$$

$$L_q = 17.0'$$

A6-8 and A6-7

$$\beta_L = 10(83) / (0.75(17.0)24.38) = \underline{2.67 \text{ k/in}}$$

$$F_{br} = 0.02 (83 \times 12) 1.0 / 24.38 = \underline{0.82 \text{ k}}$$



Brace Stiffness

The angle braces are supported by the continuous purlins that span 25' between rafters. The effect of the purlin stiffness must be considered when evaluating the stiffness of the brace system

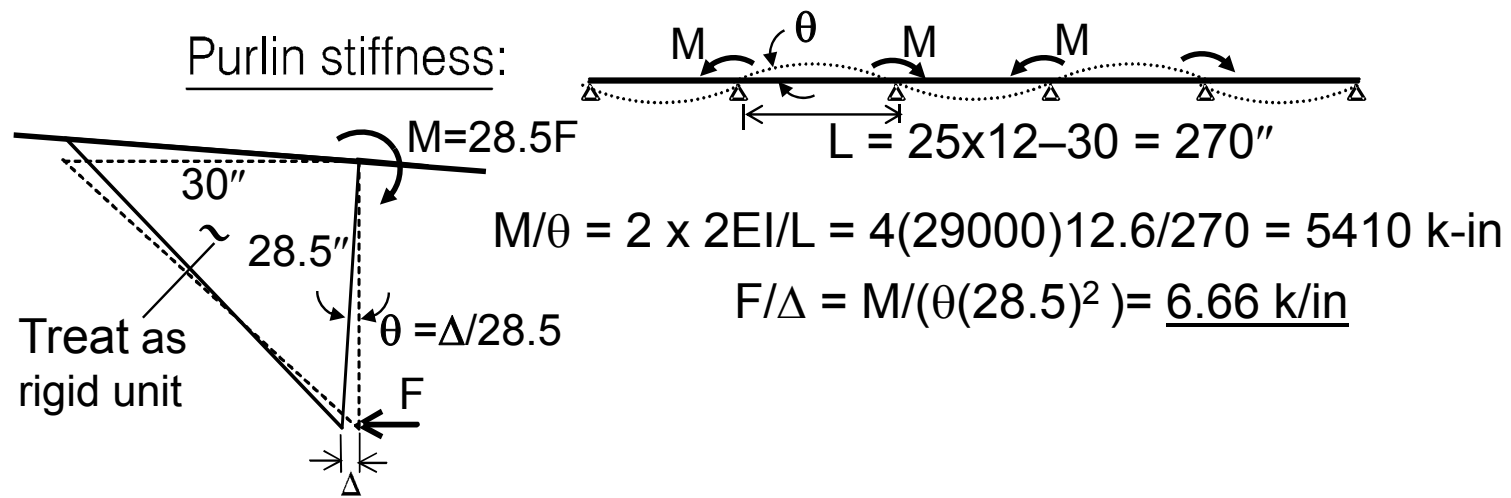

Brace Stiffness

The angle braces are supported by the continuous purlins that span 25' between rafters. The effect of the purlin stiffness must be considered when evaluating the stiffness of the brace system

Purlin stiffness:

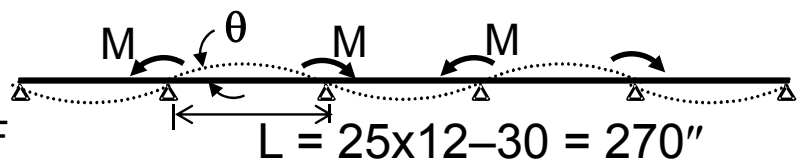

$L = 25 \times 12 - 30 = 270''$

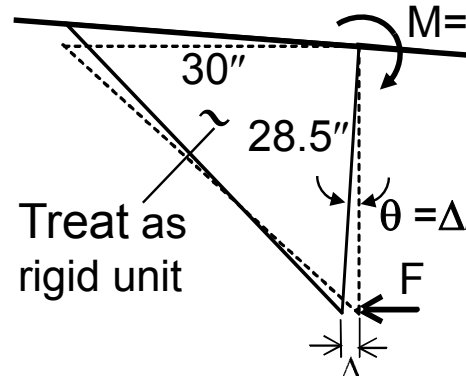

Treat as rigid unit

$M = 28.5F$

$M/\theta = 2 \times 2EI/L = 4(29000)12.6/270 = 5410 \text{ k-in}$

$F/\Delta = M/(\theta(28.5)^2) = \underline{6.66 \text{ k/in}}$

Angle stiffness: $\frac{0.297(29000)}{39.7} \cos^2\theta = \underline{124 \text{ k/in}}$

Brace stiffness: $(1/6.66) + (1/124) = (1/\beta) : \beta = \underline{6.32 > 2.67 \text{ k/in}} \text{ OK}$



Brace Stiffness

The angle braces are supported by the continuous purlins that span 25' between rafters. The effect of the purlin stiffness must be considered when evaluating the stiffness of the brace system

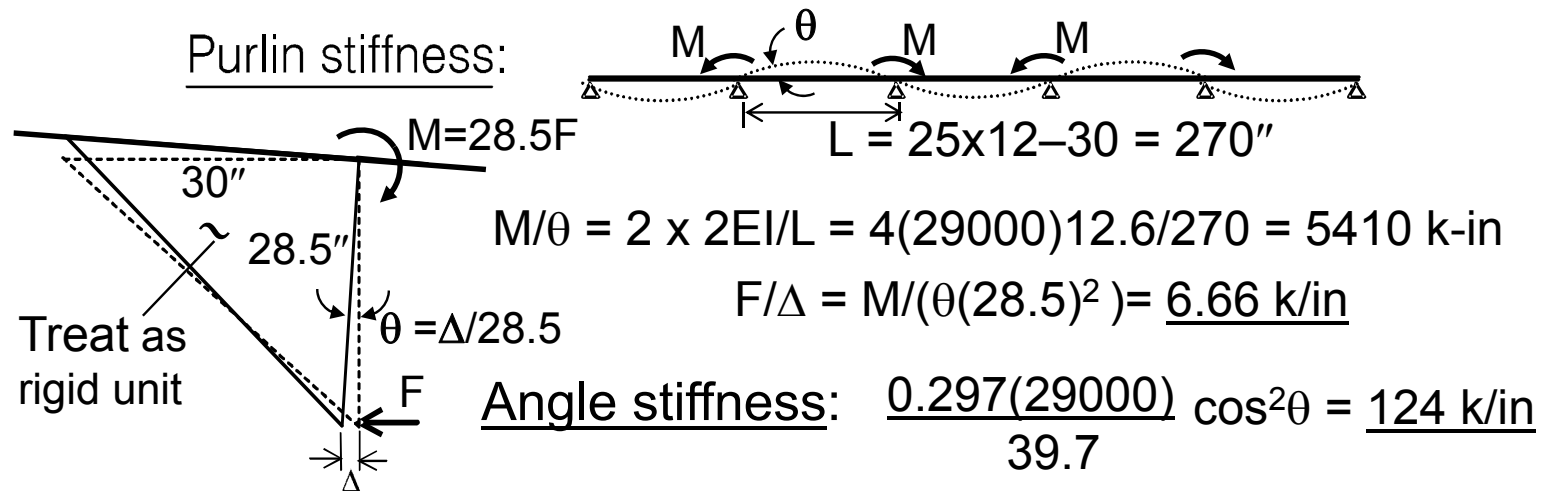

Brace stiffness: $(1/6.66) + (1/124) = (1/\beta) : \beta = \underline{6.32 > 2.67 \text{ k/in}} \text{ OK}$

Brace Strength (E5-1)

$F_y = 50 \text{ ksi}$ $KL/r = 32 + 1.25(103) = 161 : \phi F_{cr} = 8.72 \text{ ksi}$

$L/r_x = 103$ $\phi P_n = 8.72(0.297) = \underline{2.59 \text{ k} > 0.82/\cos \theta = 1.09 \text{ k}} \text{ OK}$

Polling Question 1

True or False:

For a cantilever beam, the best location for a lateral brace at the free end is the top tension flange.

47



- Bracing of single girders
 - **Torsional brace behavior and design**

TORSIONAL BRACING SYSTEMS

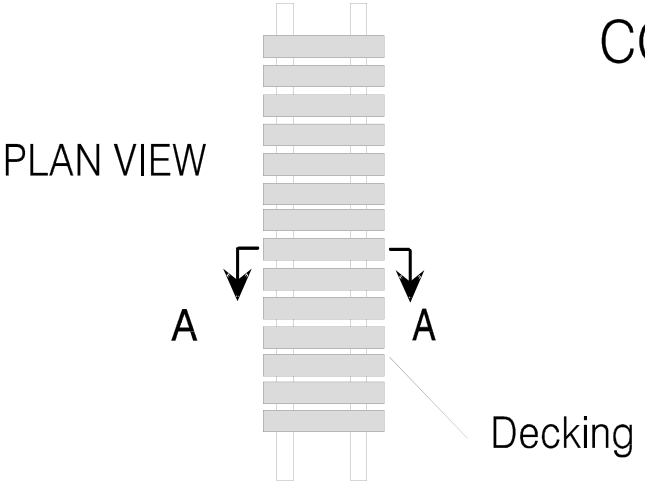
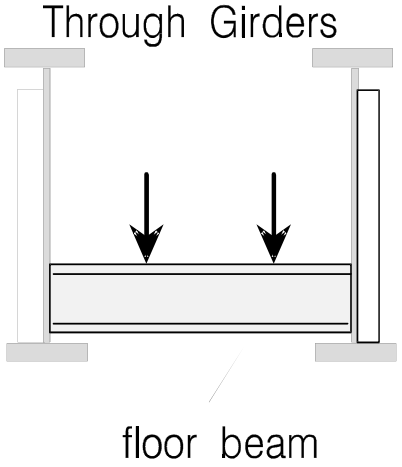
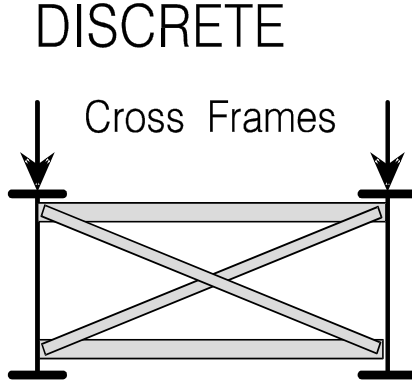
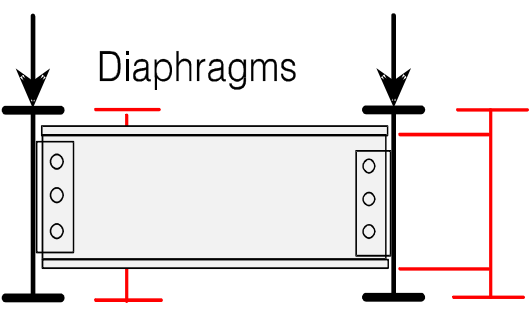

CONTINUOUS

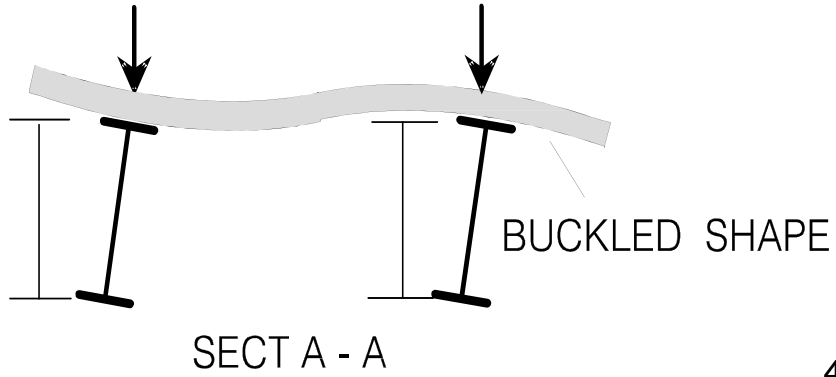

**SECTION IS FULLY BRACED AT A LOCATION
IF TWIST IS PREVENTED**

TORSIONAL BRACING - EFFECT OF STIFFENER

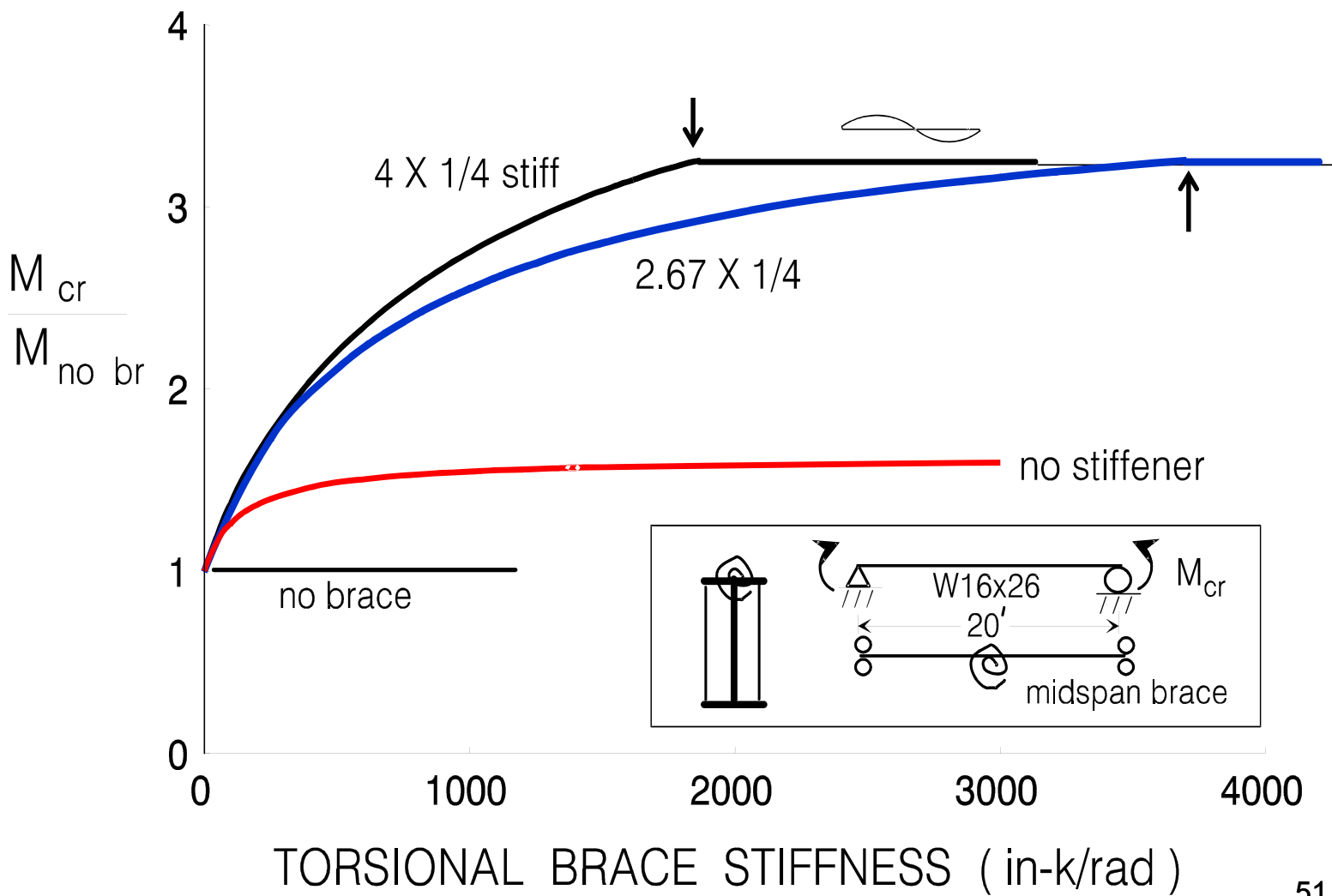





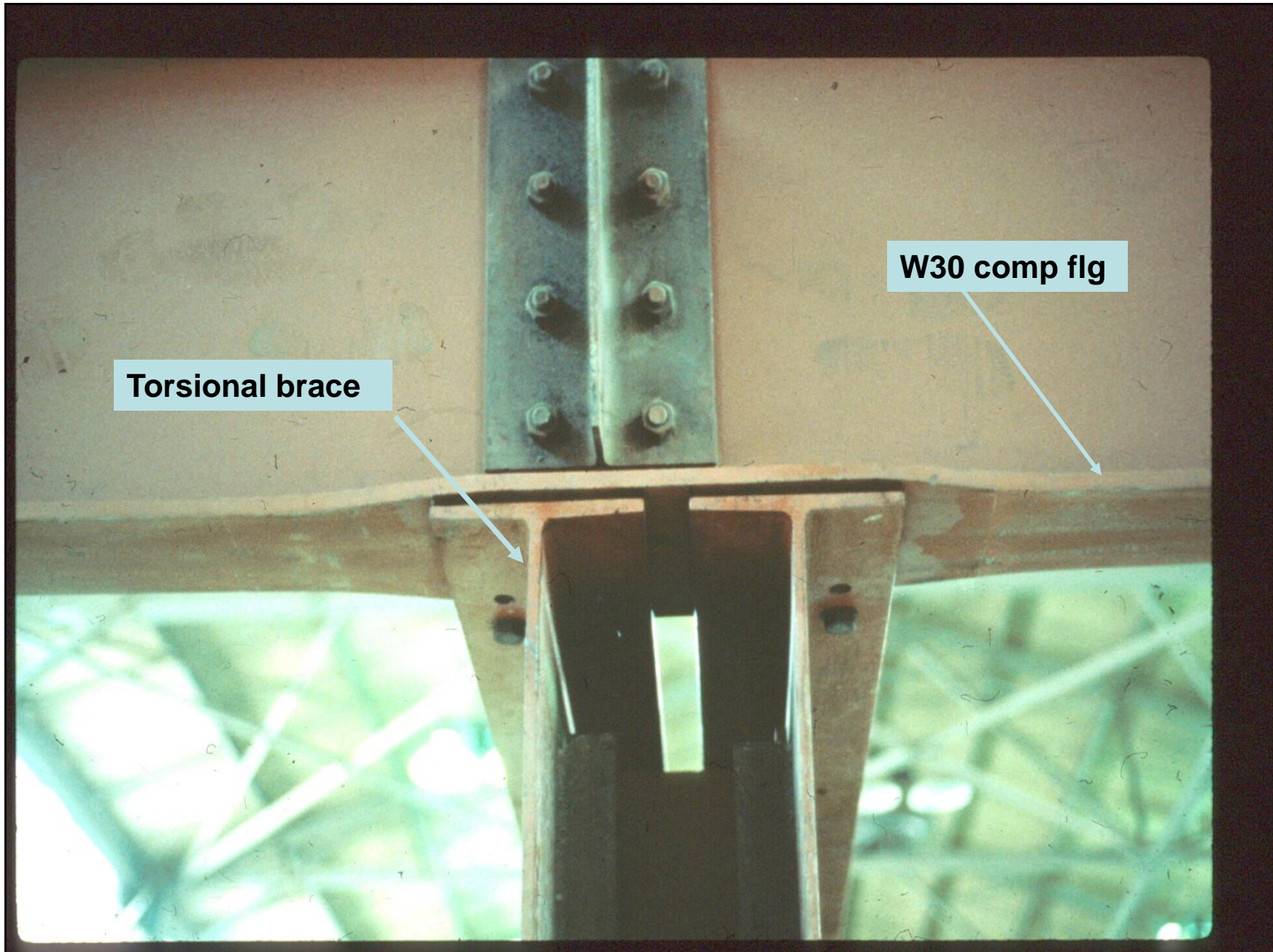



TORSIONAL BRACING DETAILS

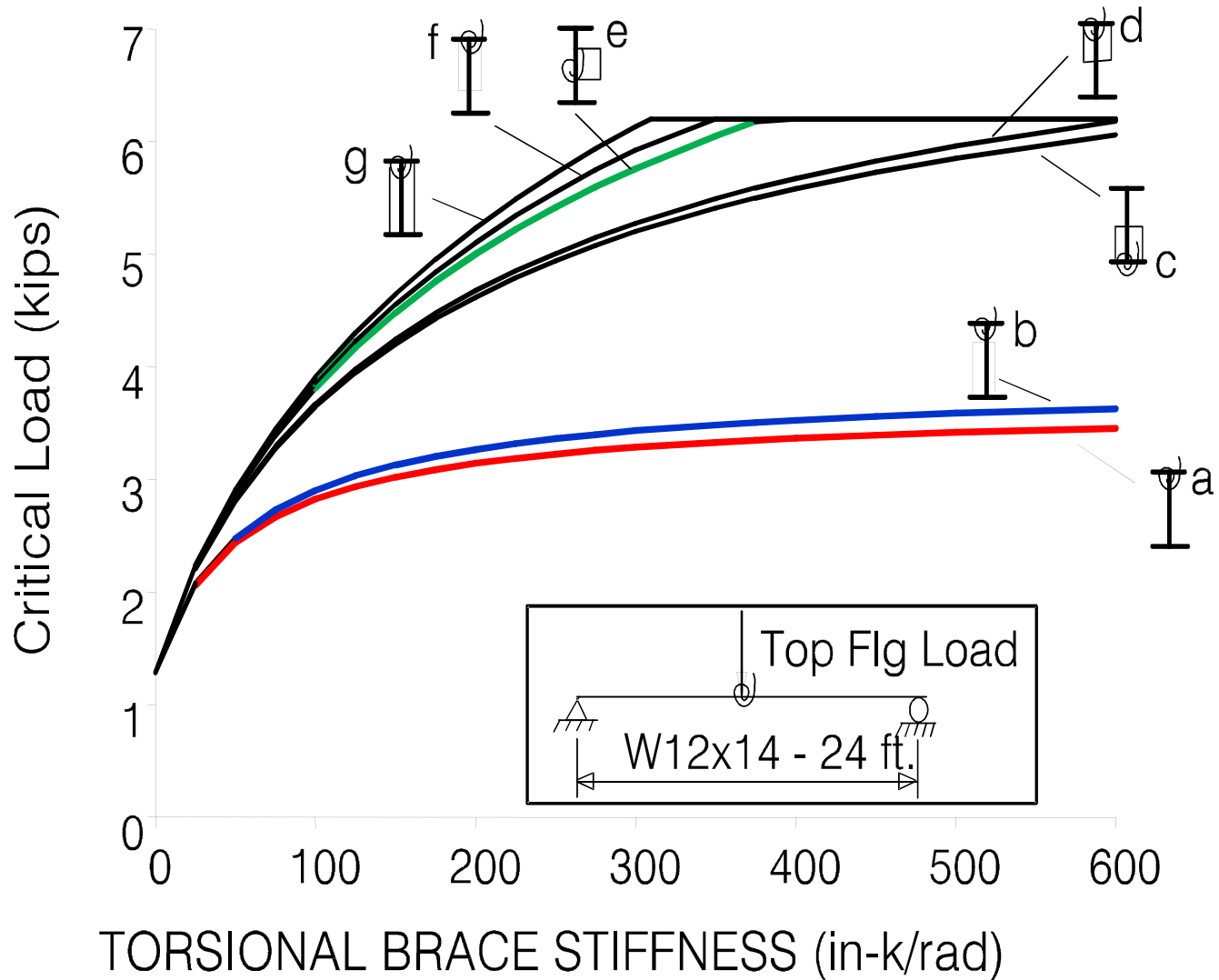

BUCKLED SHAPES AT MIDSPAN

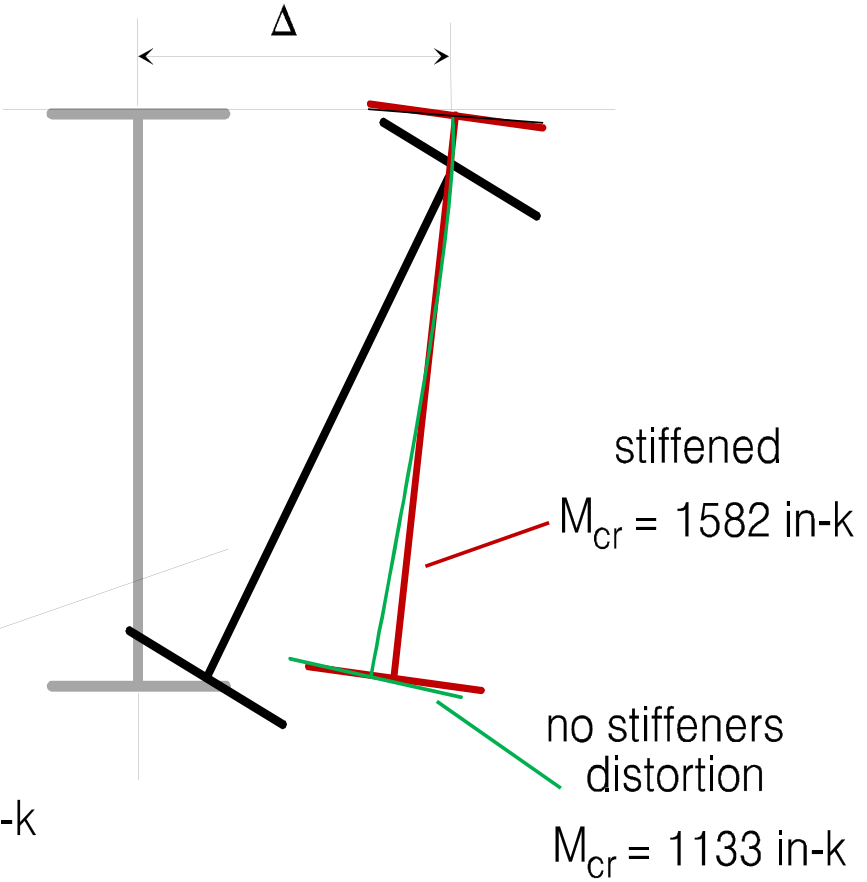
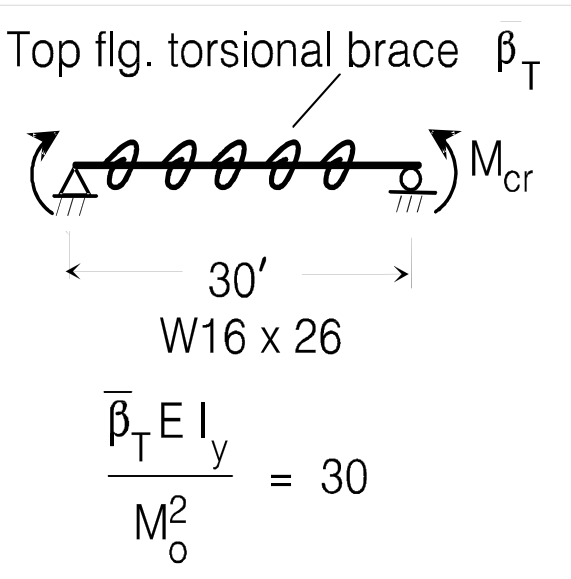

no bracing
 $M_o = M_{cr} = 283 \text{ in-k}$



EFFECT OF LOAD POSITION

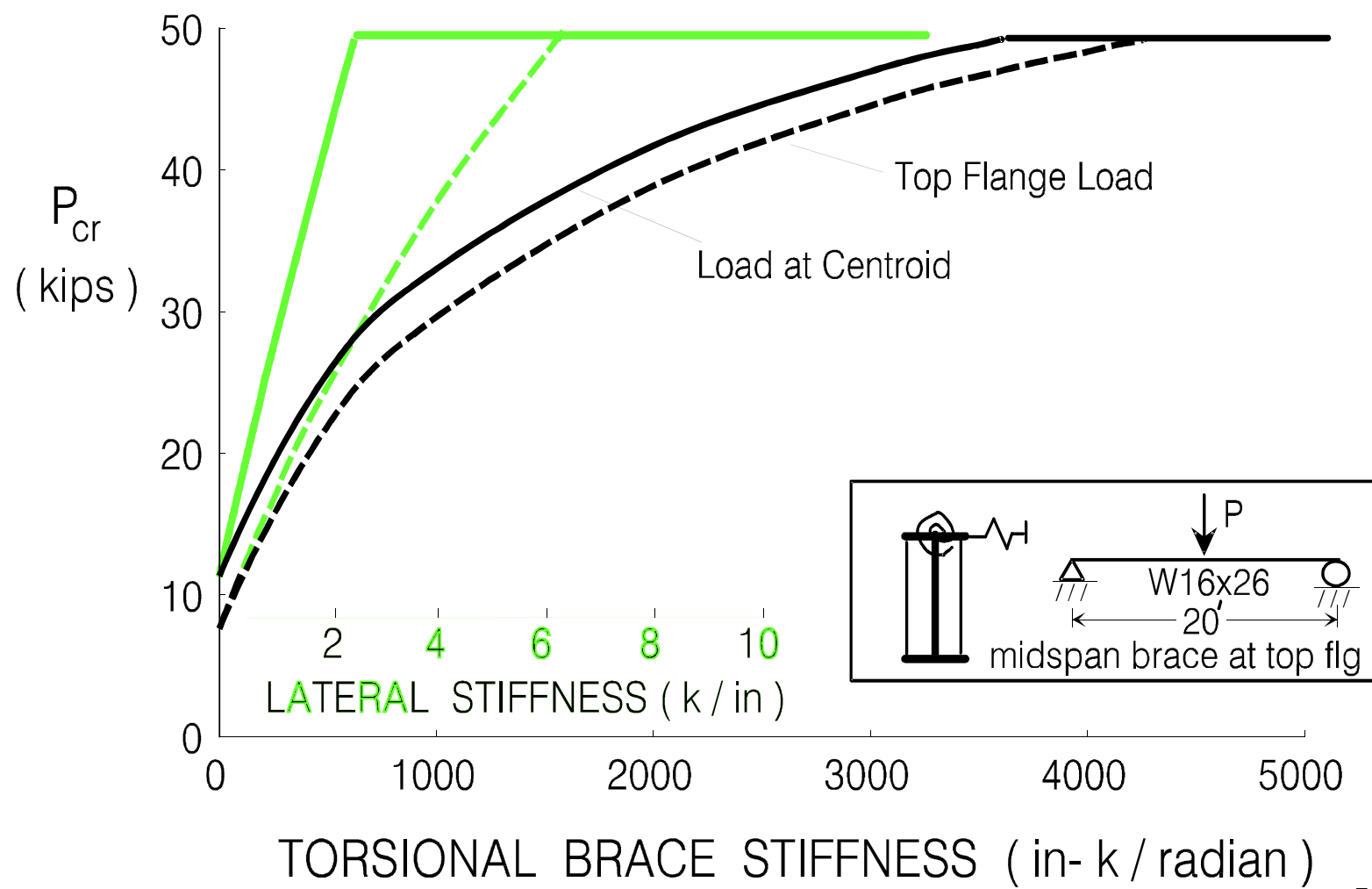

TORSIONAL BRACING TESTS

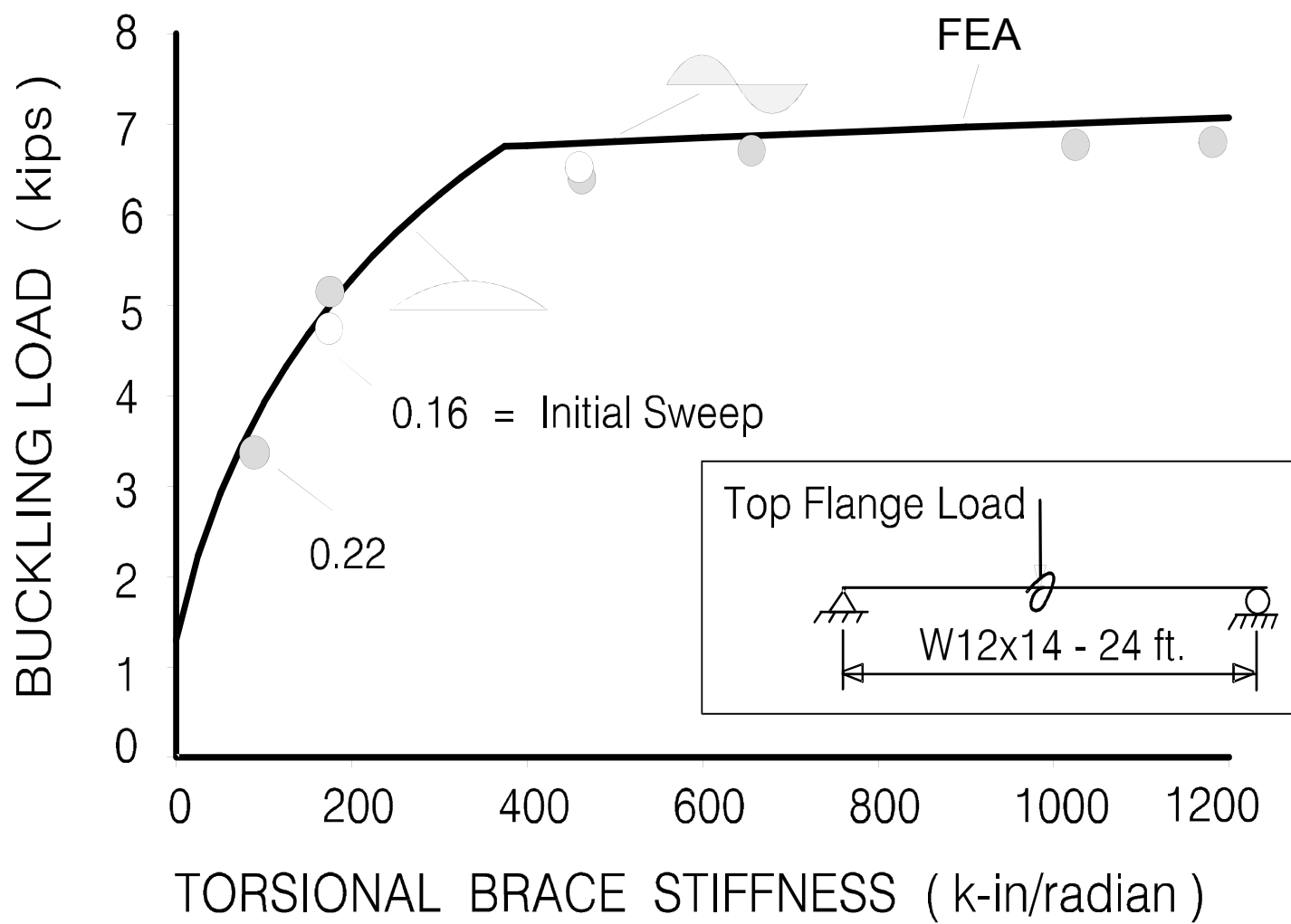

TORSIONALLY BRACED BEAMS - Taylor and Ojalvo

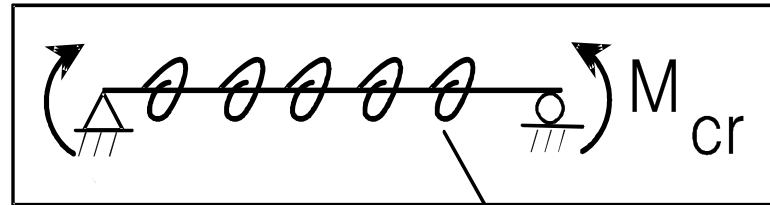

$$M_{cr} = \sqrt{M_o^2 + EI_y \bar{\beta}_T}$$

Unbraced Beam Buckling Strength

TORSIONALLY BRACED BEAMS

$$M_{cr} = \sqrt{C_{bu}^2 M_o^2 + \frac{C_{bb}^2 E I_y \bar{\beta}_T}{C_T}} \leq M_p \text{ or } M_s$$

unbraced capacity

top flange loading = 1.2

$$\bar{\beta}_T = \frac{\beta_T \times n \text{ braces}}{\text{span length}}$$

cross section distortion

$$\frac{1}{\beta_T} = \frac{1}{\beta_{Tb}} + \frac{1}{\beta_{sec}}$$



$$\frac{1}{\beta_T} = \frac{1}{\beta_{Tb}} + \frac{1}{\beta_{sec}}$$

(C-A-6-12)

β_T = System Stiffness

β_{Tb} = X-frame or Diaphragm Stiffness

β_{sec} = Web Distortional Stiffness

$$\beta_{Tb} = \frac{\beta_T}{1 - \frac{\beta_T}{\beta_{sec}}}$$

(A-6-10)

NOTE: The system stiffness is less than or at best equal to the smaller of the brace or web stiffness.

62

TORSIONAL BRACING - CROSS SECTION DISTORTION

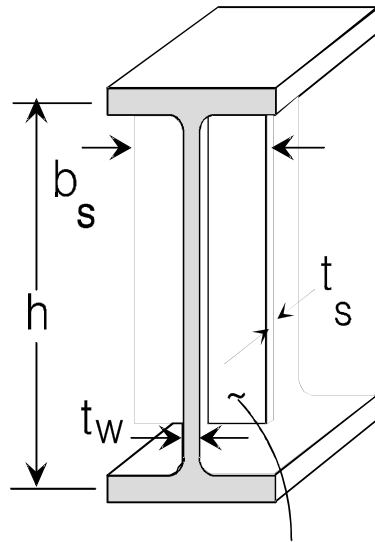

stiffener at least 3/4 depth

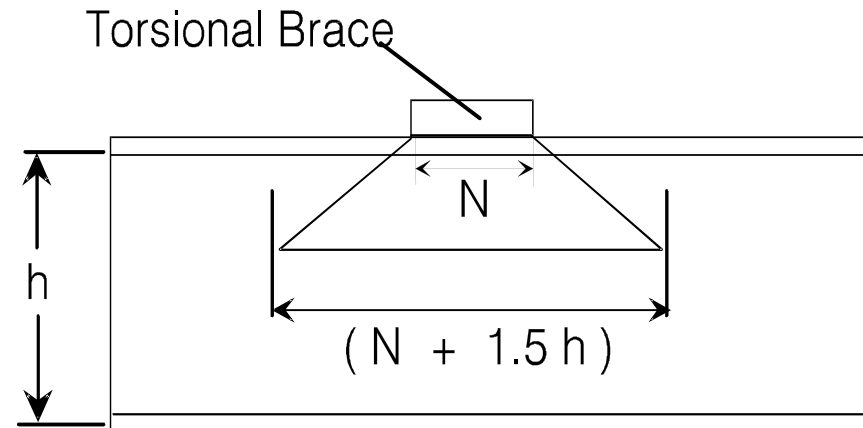

Effective Web Width for Distortion

$$\beta_{\text{sec}} = \frac{3.3 E}{h} \left(\frac{t_w^3}{12} \underbrace{(N + 1.5 h)}_{\substack{\uparrow \\ \text{use 1 in. for continuous bracing}}} + \frac{t_s^3 b_s}{12} \right)$$

APPROXIMATE BUCKLING FORMULA

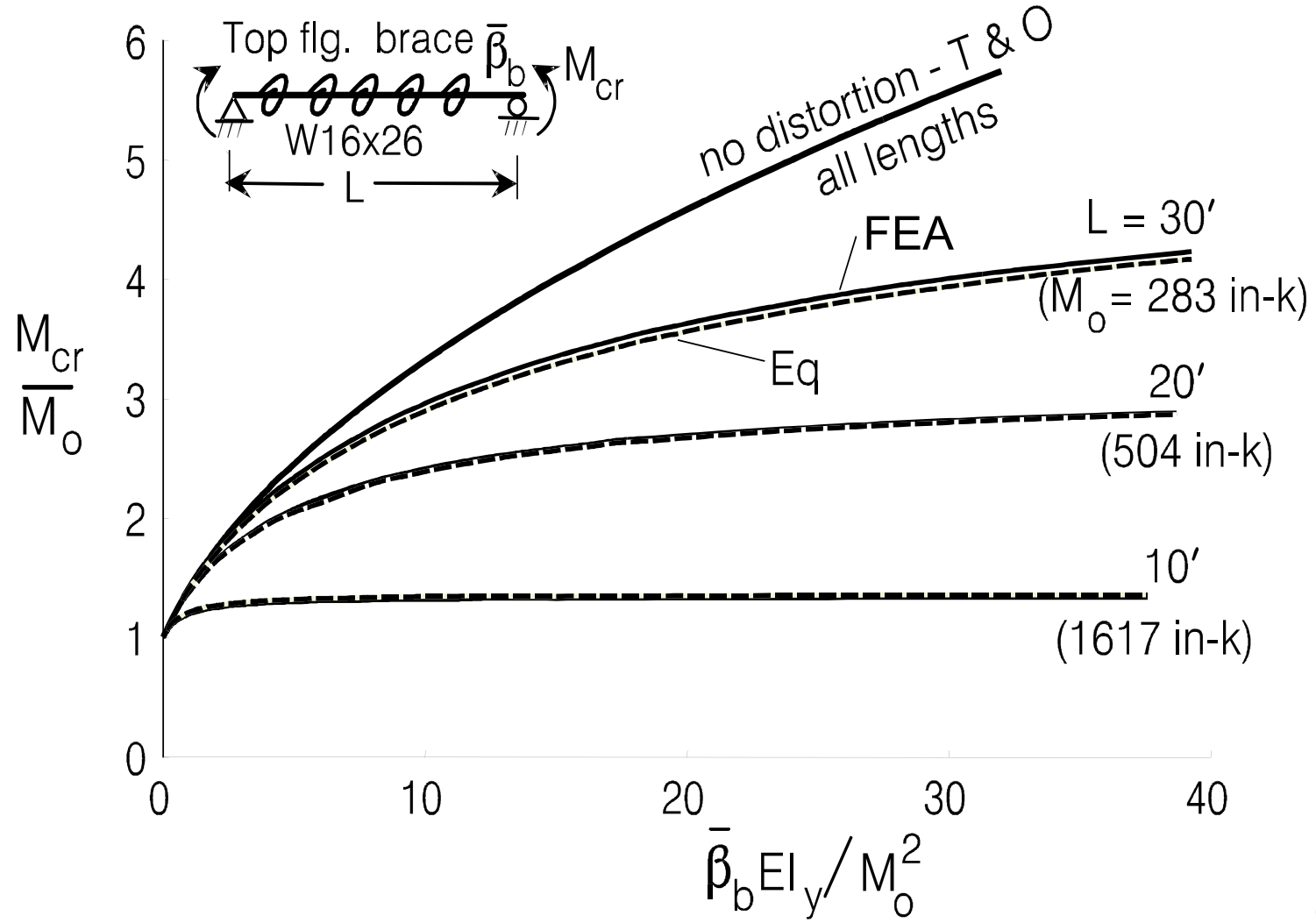

DIAPHRAGM BRACE STIFFNESS

Diaphragms
or Decks

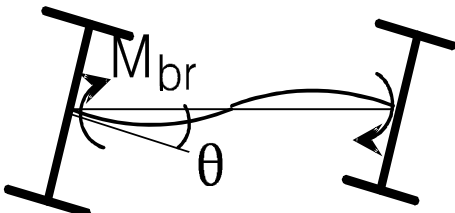
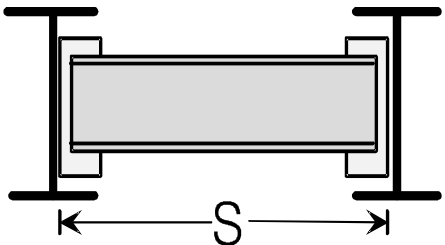

$$\beta_b = \frac{6 E I_b}{S}$$

Through Girders

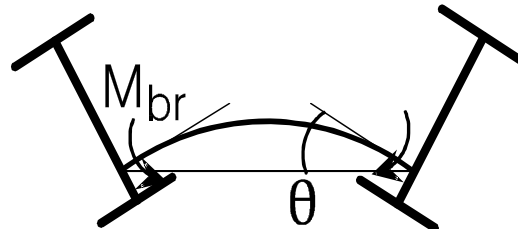
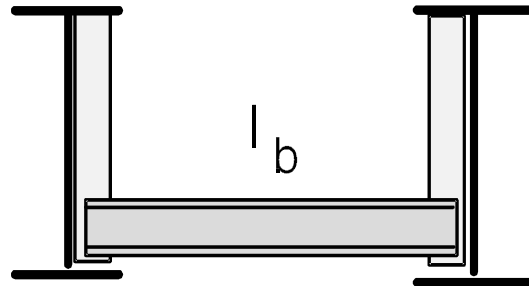

$$\beta_b = \frac{2 E I_b}{S}$$

Use if diaphragm is at midheight or closer to the compression flange



CROSS FRAME STIFFNESS

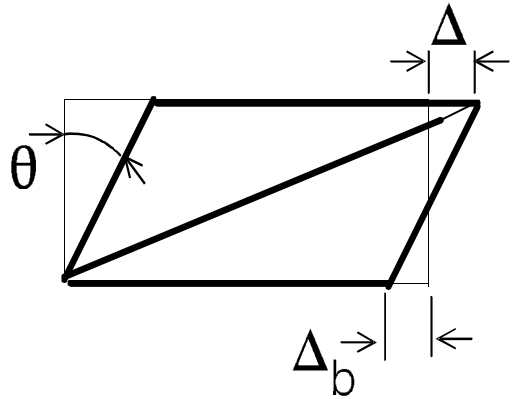
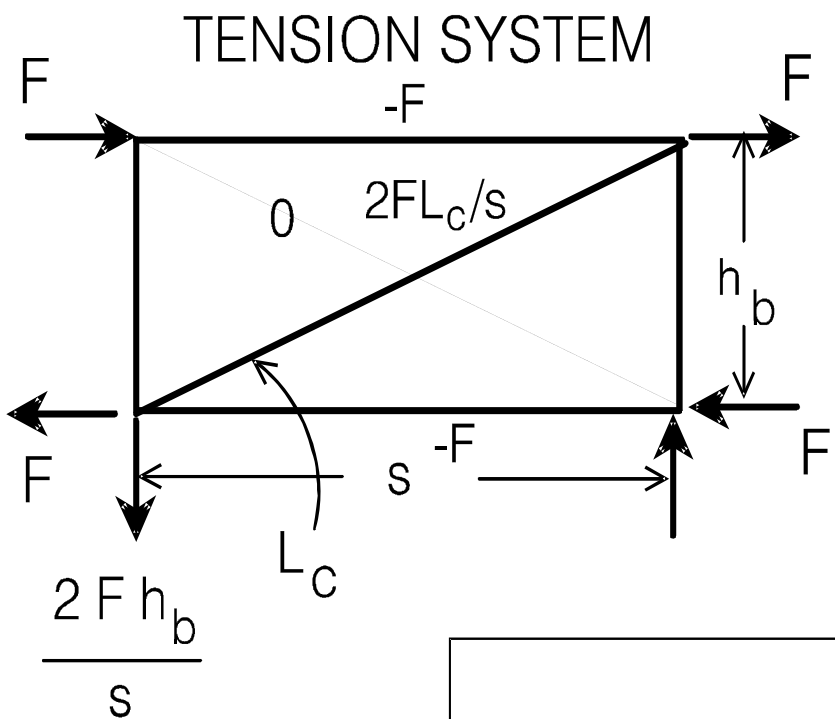

$$\theta = \frac{\Delta + \Delta_b}{h_b} \quad M = Fh_b$$

$$\beta_b = M / \theta = \frac{E s^2 h_b^2}{\frac{2L_c^3}{A_c} + \frac{s^3}{A_h}}$$

Other Geometries
 in Reference



Recent Tests: Cross Frame Specimens

Battistini et al(2016), J. of Bridge Engrg.,ASCE, Vol 21, No.6



Single Angle X-Frame



Double Angle Z-Frame
(Single Angle Struts)



Double Angle Z-Frame
(Double Angle Struts)





Single Angle K-Frame

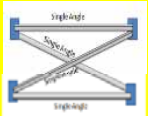
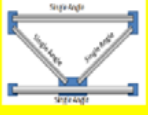
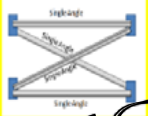

Square Tube Z-Frame

Stiffness: Test vs. Analytical vs. FEA

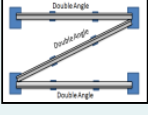
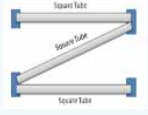
Type of Cross Frames	Test Results	Analytic Solution	Error %	Line Element Solution	Error %
Single Angle X Frame 	872,000	1,579,000	82%	1,572,000	81%
Single Angle K Frame 	760,000	1,189,000	56%	1,180,000	55%
Unequal Leg Angle X Frame 	1,054,000	1,609,000	53%	1,614,000	53%
Double Angle Z (Single Struts) 	597,000	907,000	52%	905,000	52%
Double Angle Z (Double Struts) 	1,182,000	1,152,000	-2.5%	1,152,000	-2.5%
Square Tube Z-frame 	658,000	649,000	-1%	647,000	-2%

ECCENTRIC CONNECTION



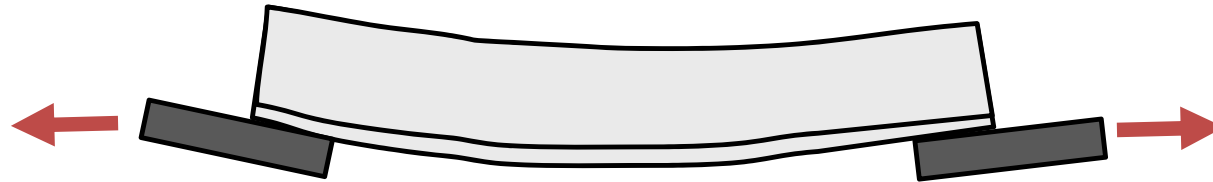

**The reduction in the stiffness is due to the bending
caused by the eccentric connection**

Reduce stiffness 50 % for eccentric connections

What about the angle brace in the earlier lateral brace example?

Brace Stiffness

The angle braces are supported by the continuous purlins that span 25' between rafters. The effect of the purlin stiffness must be considered when evaluating the stiffness of the brace system

Purlin stiffness:

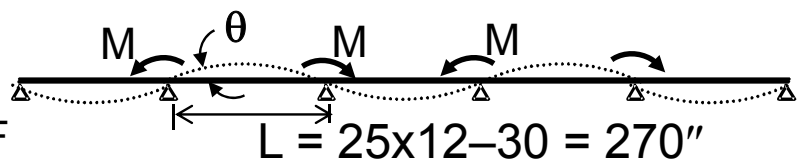

$L = 25 \times 12 - 30 = 270''$

$M/\theta = 2 \times 2EI/L = 4(29000)12.6/270 = 5410 \text{ k-in}$

$F/\Delta = M/(\theta(28.5)^2) = \underline{6.66 \text{ k/in}}$

Angle stiffness: $\frac{0.297(29000)}{39.7} \cos^2\theta = \underline{62} \text{ k/in}$ (Note: ~~124~~ is crossed out and 62 is written in red)

Brace stiffness: $(1/6.66) + (1/\underline{62}) = (1/\beta) : \beta = \underline{6.01} > 2.67 \text{ k/in OK}$ (Note: ~~6.32~~ is crossed out and 6.01 is written in red)

Brace Strength (E5-1)

$$F_y = 50 \text{ ksi} \quad KL/r = 32 + 1.25(103) = 161 : \phi F_{cr} = 8.72 \text{ ksi}$$

$$L/r_x = 103 \quad \phi P_n = 8.72(0.297) = \underline{2.59 \text{ k}} > 0.82/\cos \theta = 1.09 \text{ k OK}$$

SINGLY - SYMMETRIC GIRDERS

$$M_{cr} = \sqrt{C_{bu}^2 M_o^2 + \frac{C_{bb}^2 E I_y \bar{\beta}_T}{C_T}} \leq M_p \text{ or } M_s$$

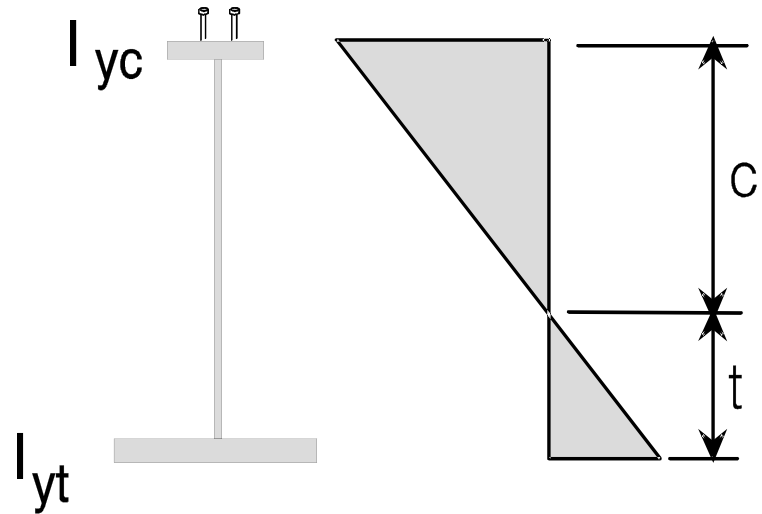

$$I_{eff} = I_{yc} + \frac{t}{c} I_{yt}$$



DEVELOPMENT OF DESIGN RECOMMENDATIONS

$$\beta_T = \frac{2.4 L M_r^2}{n C_b^2 E I_y}$$

Strength : $M_{br} = \theta \beta_T$ - take $\theta = 0.002 L_b/h$

$$M_{br} = \frac{0.005 L M_r^2}{n C_b^2 E I_y} \frac{L_b}{h}$$

(C-A-6-8)

This was further simplified – See AISC Commentary for details

73

TORSIONAL BRACING - LRFD RECOMMENDATIONS

STIFFNESS :

$$\beta_T = \frac{2.4 M_r^2 L}{\phi n E I_y C_{bb}^2} \quad (A-6-11)$$

STRENGTH :

$$M_{br} = F_{br} h_b = \frac{0.024 M_r L}{n C_{bb} L_b} \quad (A-6-9)$$

ASSUMES INITIAL TWIST = $\frac{L_b}{500h}$

L_b — brace spacing
 $500h$ — beam depth

Note: The required bracing spacing, L_q , can be substituted for the actual spacing, L_b .

TORSIONAL BEAM BRACING

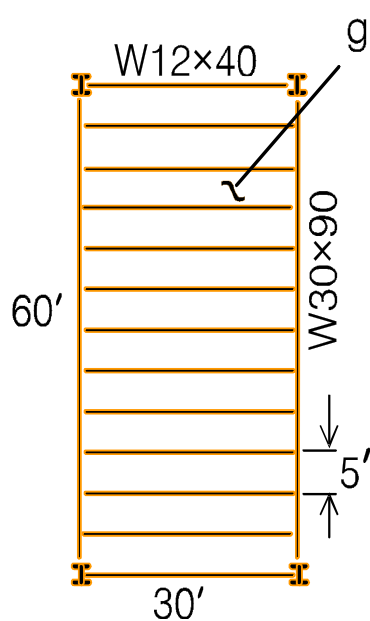

glass (no diaphragm)

The grillage supports glass roof panels subjected to uniform load. The maximum beam moments are:
 (W12x40) $M_r = 45 \text{ k}' < \phi M_n = 97 \text{ k}'$ ($L_b = 30'$, $C_b = 1.14$)
 (W30x90) $M_r = 583 \text{ k}' > \phi M_n = 144 \text{ k}'$ ($L_b = 60'$, $C_b = 1.14$)
 \therefore the W30x90 needs bracing from the W12x40
 From p.3-123, AISC Manual, $L_q = 22.1'$ for $\phi M_n = 583 \text{ k}'$

$F_y = 50 \text{ ksi}$

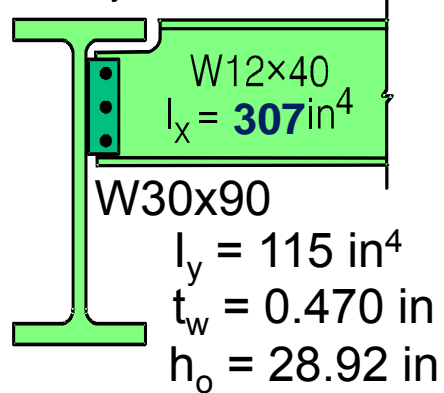

TORSIONAL BEAM BRACING

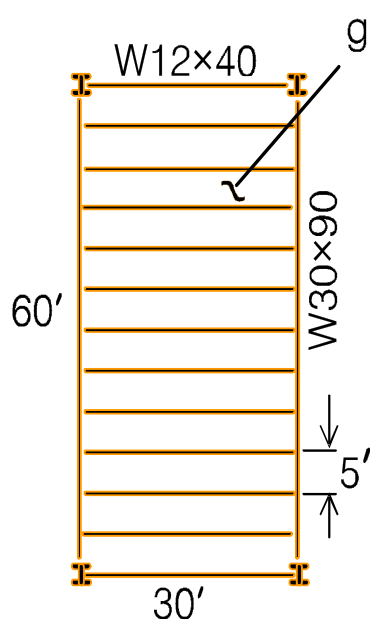

The grillage supports glass roof panels subjected to uniform load. The maximum beam moments are:
 (W12x40) $M_r = 45 \text{ k}' < \phi M_n = 97 \text{ k}'$ ($L_b = 30'$, $C_b = 1.14$)
 (W30x90) $M_r = 583 \text{ k}' > \phi M_n = 144 \text{ k}'$ ($L_b = 60'$, $C_b = 1.14$)
 \therefore the W30x90 needs bracing from the W12x40
 From p.3-123, AISC Manual, $L_q = 22.1'$ for $\phi M_n = 583 \text{ k}'$

Brace Requirements

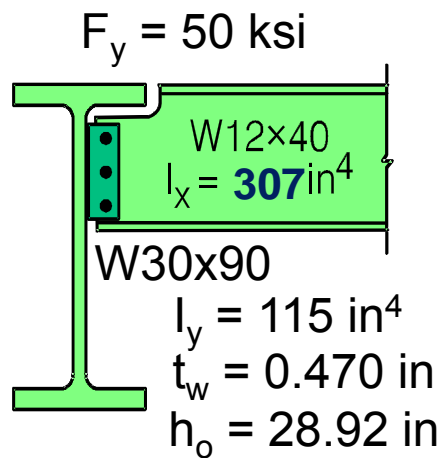

(A6-11)
$$\beta_T = \frac{2.4(60 \times 12)(583 \times 12)^2}{0.75(11)(29000)(115)(1.0)^2} = \underline{3074 \text{ in-k/rad}}$$

(A6-9) Use $L_q = 22.1'$ instead of $L_b = 5'$

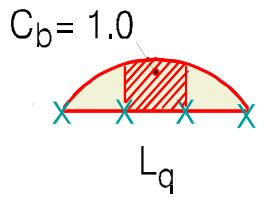

$$M_{br} = \frac{0.024(583)60}{11(1.0)22.1} = \underline{3.45 \text{ k}'}$$

Try W12×40 as bracing - assume that the shear tab connection can act as a moment connection for the small M_{br}

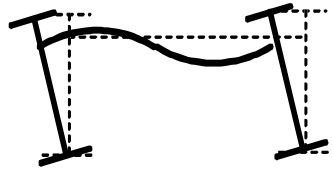

$$\beta_{Tb} = 6EI/L = 6(29000)307/(30 \times 12) = \boxed{148,400 \text{ in-k/radian}}$$

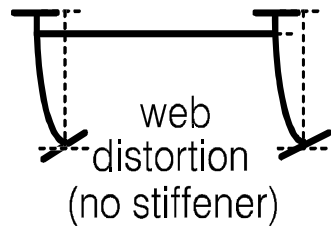

$$(A6-12) \quad \beta_{sec} = \frac{3.3(29000)}{28.92} \left(\frac{1.5(28.92)(0.47)^3}{12} + 0 \right)$$

$$= \underline{1242} < 3074 \text{ in-k/rad} \therefore \underline{\text{need web stiffeners}} \\ \text{(or thicker web)}$$

Try W12×40 as bracing - assume that the shear tab connection can act as a moment connection for the small M_{br}

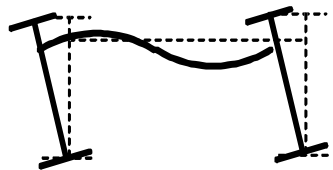

$$\beta_{Tb} = 6EI/L = 6(29000)307/(30 \times 12) = \boxed{148,400 \text{ in-k/radian}}$$

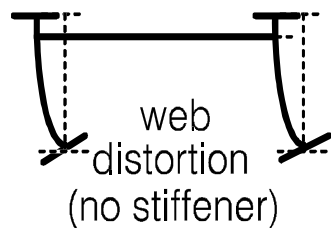

$$(A6-12) \quad \beta_{sec} = \frac{3.3(29000)}{28.92} \left(\frac{1.5(28.92)(0.47)^3}{12} + 0 \right)$$

$$= \underline{1242} < 3074 \text{ in-k/rad} \therefore \underline{\text{need web stiffeners}} \\ \text{(or thicker web)}$$

$$(C-A-6-12) \quad \frac{1}{3074} = \frac{1}{148,400} + \frac{1}{\beta_{sec}} \quad ; \text{ required } \beta_{sec} = 3140 \text{ in-k/rad}$$

Assume 3/8 thick stiffener -

$$3140 = \frac{3.3(29000)}{28.92} \left(\frac{1.5(28.92)(0.47)^3}{12} + \frac{0.375(b_s)^3}{12} \right) \quad ; b_s = 2.63 \text{ in}$$

- use 4×3/8 full-depth one-sided stiffener for connection

79

Brace strength:

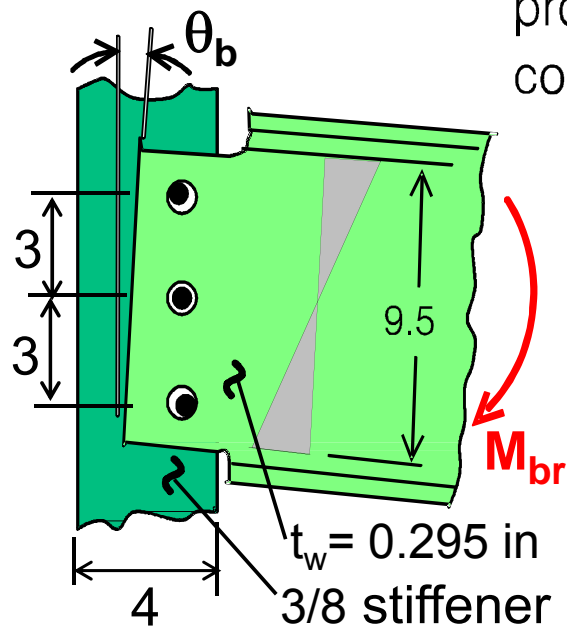

The bolted connection to the coped W12×40 can provide moment capacity as the bolts come in contact with the web when the beam tries to rotate.

$\phi M_n = 0.9 S F_y$ where S is the section modulus of the web in the connection zone

$$\phi M_n = 0.9(50)(9.5)^2(0.295)/6(12) = 16.6 \text{ k-ft}$$

$$\phi M_n > M_{br} = 3.45 \text{ k-ft OK}$$

Because of hole clearance, some rotation, θ_b , may occur before flexural resistance can be developed. Check **increase** in brace force.

$$\text{Say } \theta_b = (2/16") \div 6" = 0.0208 \quad \theta_o = 0.002(22.1 \times 12)/28.92 = 0.0183$$

$$M_{br} = 3.45 \left(\frac{0.0208 + 0.0183}{0.0183} \right) = 7.37 < 16.6 \text{ k-ft, still OK}$$

Minimum Web Thickness to Eliminate the Web Stiffeners

$$(C-A-6-12) \frac{1}{3074} = \frac{1}{148,400} + \frac{1}{\beta_{sec}} \quad : \text{required } \beta_{sec} = \underline{3139 \text{ in-k/rad}}$$

$$(A6-12) \quad 3139 = 3.3(29000)(1.5 t_w^3)/12 \quad \therefore \text{approx. min } t_w = \underline{0.640 \text{ in}}$$

W30x148 ($t_w = 0.650 \text{ in}$)

Minimum Web Thickness to Eliminate the Web Stiffeners

$$(C-A-6-12) \frac{1}{3074} = \frac{1}{148,400} + \frac{1}{\beta_{sec}} \quad : \text{required } \beta_{sec} = \underline{3139 \text{ in-k/rad}}$$

$$(A6-12) \quad 3139 = 3.3(29000)(1.5 t_w^3)/12 \quad \therefore \text{approx. min } t_w = \underline{0.640 \text{ in}}$$

W30x148 ($t_w = 0.650 \text{ in}$)

Try W30x124, $t_w = 0.585 \text{ in}$, ϕM_n unbraced = 284 k' ($M_r = 583 \text{ k}'$)

Account for unbraced buckling strength :

Replace M_r^2 with $(M_r^2 - (\phi M_n)^2)$ (AISC C-A-6-7)

$$\beta_T = 3074 (583^2 - 284^2) / 583^2 = \underline{2344 \text{ in-k/rad}}$$

$$(C-A-6-12) \frac{1}{2344} = \frac{1}{148,400} + \frac{1}{\beta_{sec}} \quad : \text{required } \beta_{sec} = \underline{2381 \text{ in-k/rad}}$$

$$(A6-12) \quad 2381 = 3.3(29000)(1.5 t_w^3)/12 \quad \therefore \text{min } t_w = \underline{0.583 < 0.585 \text{ in}}$$

OK 82

Polling Question

To be effective, a torsional brace system must

- a. be attached near the compression flange
- b. prevent lateral movement and twist
- c. have a web stiffener
- d. limit distortion
- e. all of the above

END CONNECTION TORSIONAL RESTRAINT

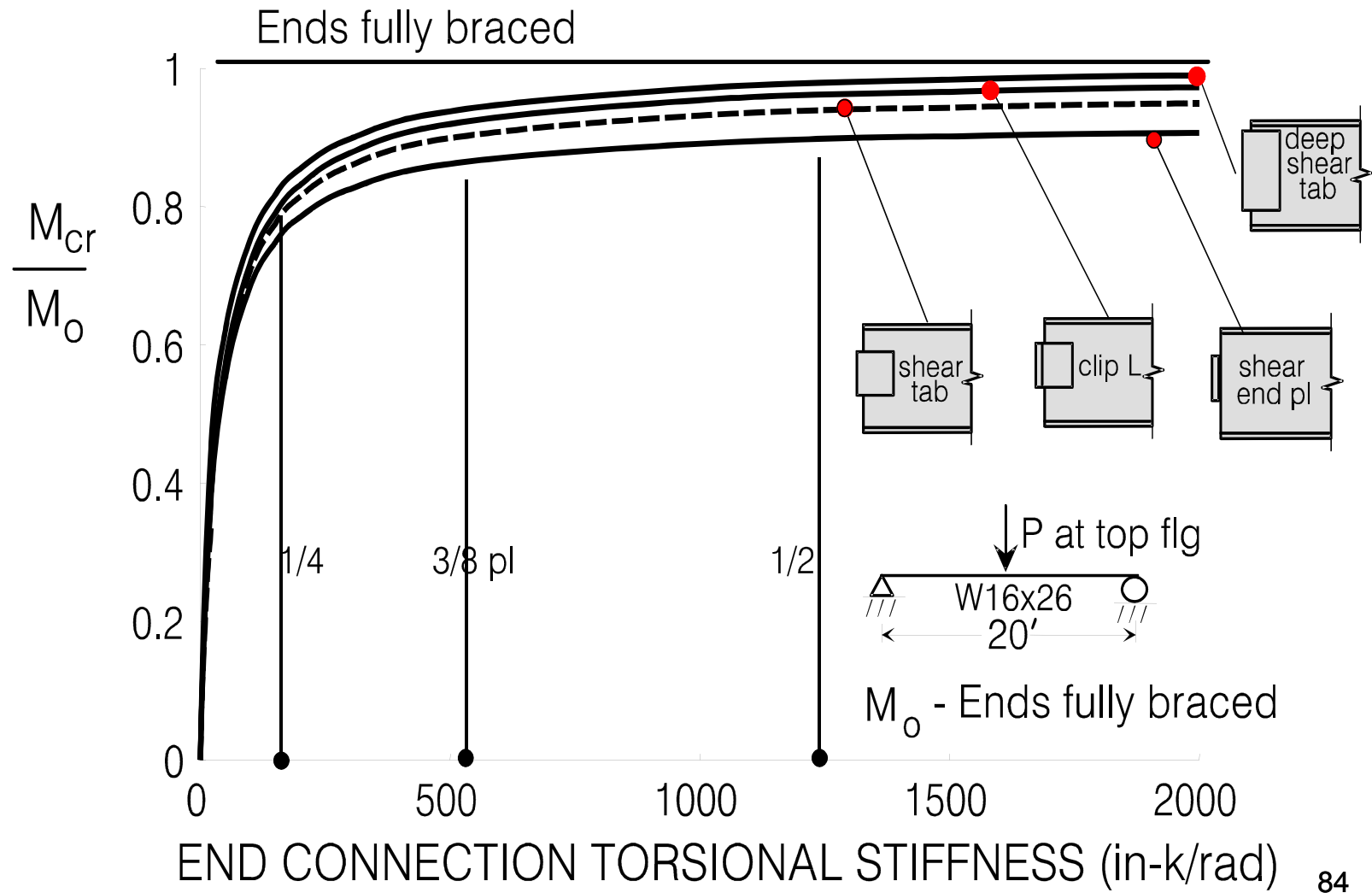

SUMMARY

- Closely-spaced long-span beams can buckle as a unit
- Beam braces can be designed to either prevent movement of the compression flange(s) or twist of the cross section
- Braces must have adequate stiffness in addition to strength
- Distortion of the cross section must be controlled for effective torsional bracing

www.stabilitycouncil.org

CHAPTER 12

BRACING

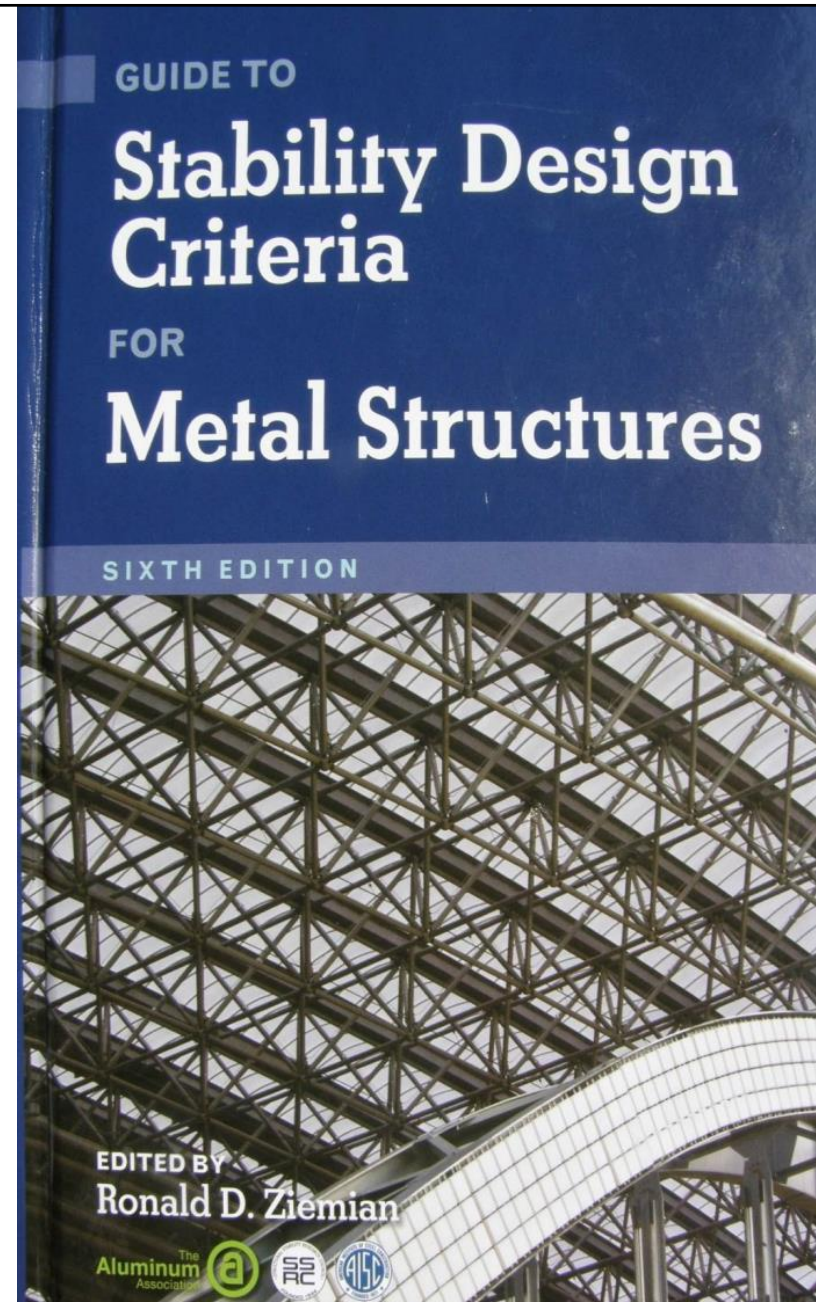

86

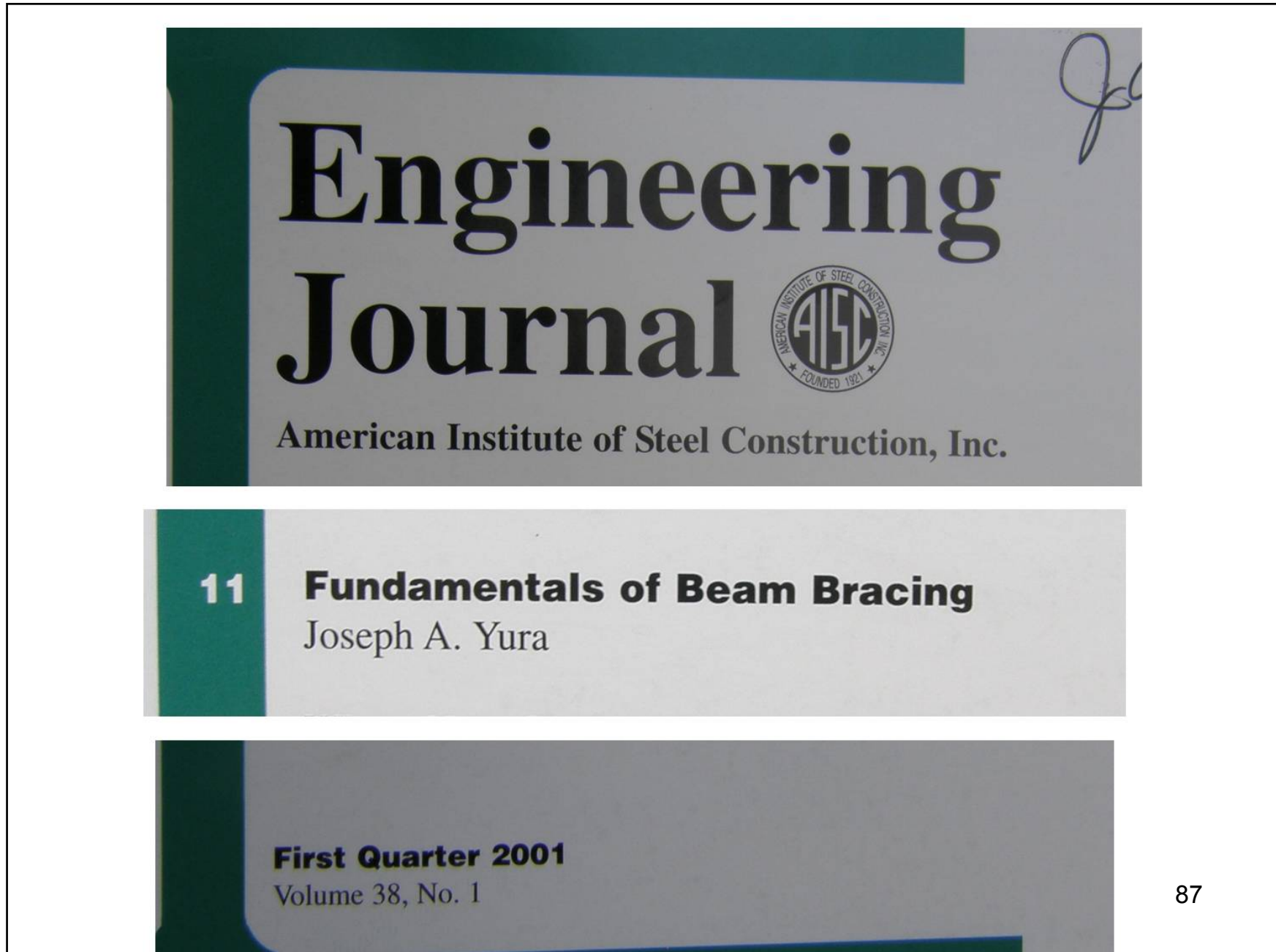

Individual Webinar Registrants

CEU/PDH Certificates

Within 2 business days...

- You will receive an email on how to report attendance from: registration@aisc.org.
- Be on the lookout: Check your spam filter! Check your junk folder!
- Completely fill out online form. Don't forget to check the boxes next to each attendee's name!



Individual Webinar Registrants

CEU/PDH Certificates

Within 2 business days...

- New reporting site (URL will be provided in the forthcoming email).
- Username: Same as AISC website username.
- Password: Same as AISC website password.



8-Session Registrants

CEU/PDH Certificates

One certificate will be issued at the conclusion of
all 8 sessions.



8-Session Registrants

Final Exam

The final exam will be issued on August 14.

The final exam must be submitted by August 28 at 8:00 AM EDT.



8-Session Registrants

Access to the quiz: Information for accessing the quiz will be emailed to you by Wednesday. It will contain a link to access the quiz. EMAIL COMES FROM NIGHTSCHOOL@AISC.ORG

Quiz and Attendance records: Posted Tuesday mornings.
www.aisc.org/nightschool - click on Current Course Details.

Reasons for quiz:

- EEU – must take all quizzes and final to receive EEU
- CEUs/PDHS – If you watch a recorded session you must take quiz for CEUs/PDHS.
- REINFORCEMENT – Reinforce what you learned tonight. Get more out of the course.

NOTE: If you attend the live presentation, you do not have to take the quizzes to receive CEUs/PDHS.



8-Session Registrants

Access to the recording: Information for accessing the recording will be emailed to you by this Wednesday. The recording will be available for three weeks. For 8-session registrants only. EMAIL COMES FROM NIGHTSCHOOL@AISC.ORG.

CEUs/PDHS – If you watch a recorded session you must take AND PASS the quiz for CEUs/PDHS.



Night School Resources for 8-session package Registrants

Find all your handouts, quizzes and quiz scores,
recording access, and attendance information all in
one place!



Night School Resources for 8-session package Registrants

Go to www.aisc.org and sign in.



Login

If you're an existing customer, please enter your username and password.

USERNAME

PASSWORD

Remember Me

DON'T HAVE AN ACCOUNT?

My AISC allows you to access Engineering Journal articles and Design Guides you have downloaded from the bookstore.

[REGISTER NOW](#)

Night School Resources for 8-session package Registrants

Go to www.aisc.org and sign in.

The screenshot displays the MyAISC user interface. On the left, a vertical menu titled "IN THIS SECTION" lists several options: "Edit Profile", "My Downloads", "My Pending Quizzes", "My Events", "Order History", "Course History", and "Course Resources". The "Course Resources" option is circled in red. The main content area is titled "MyAISC" and is divided into three sections: "MY PROFILE" with an "EDIT PROFILE" button, "MY PURCHASED DOWNLOADS" with a "VIEW DOWNLOADS" button, and "MY COURSE RESOURCES" with a "VIEW RESOURCES" button. The "MY COURSE RESOURCES" section and its button are also circled in red.

Night School Resources for 8-session package Registrants

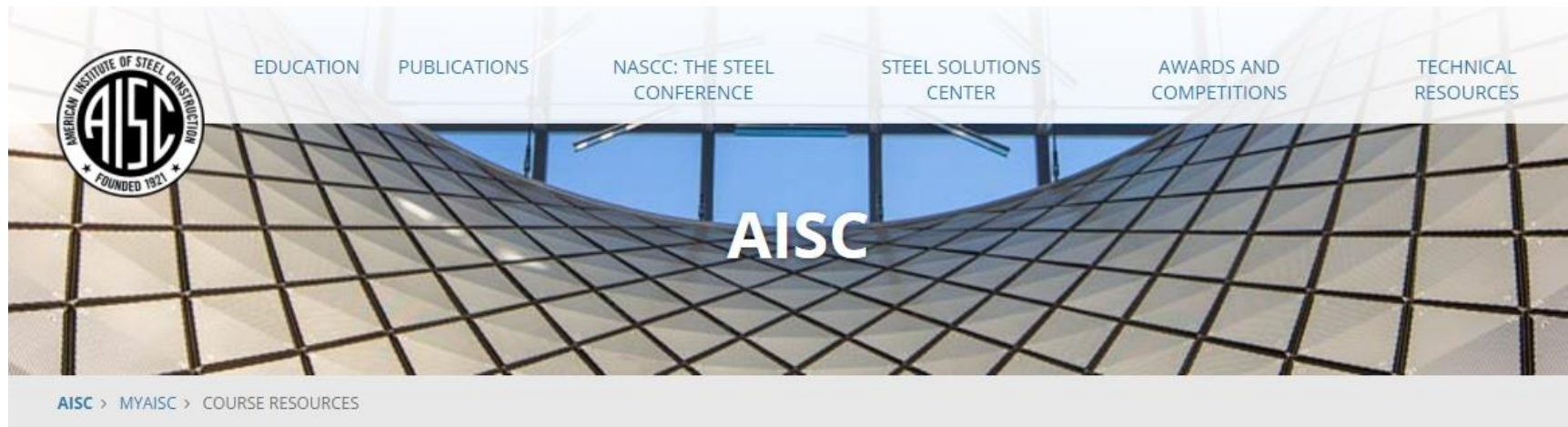

Course Resources

Event	Start Date
NS 13 8-Session Package-Night School 13 - Design of Industrial Buildings	1/30/2017 7:00:00 PM
NS 14 8-Session Package-Night School 14 - Fundamentals of Stability	6/5/2017 7:00:00 PM

Night School Resources for 8-session package Registrants



Night School 13: Design of Industrial Buildings

8-SESSION PACKAGE RESOURCES

Event	Date	Handouts	Video	Quiz	Attendance
NS13 - Design Criteria	1/30/2017 7:00:00 PM	Handouts	View Passcode: NS13DSN	Pass Score: 80	Pending
NS13 - Economic Considerations	2/6/2017 7:00:00 PM	Handouts	Available 02/08/2017 5pm EST	Available 02/08/2017 5pm EST	Pending
NS13 - Lateral Load Systems and Details	2/13/2017 7:00:00 PM	Handouts	Available 02/15/2017 5pm EST	Available 02/15/2017 5pm EST	Pending
NS13 - Preliminary Design Procedures	2/27/2017 7:00:00 PM	Handouts	Available 03/01/2017 5pm EST	Available 03/01/2017 5pm EST	Pending
NS13 - Crane Girder Design and Frame Analysis	3/6/2017 7:00:00 PM	Handouts	Available 03/08/2017 5pm EST	Available 03/08/2017 5pm EST	Pending
NS13 - Frame Member and Connection Design	3/13/2017 7:00:00 PM	Handouts	Available 03/15/2017 5pm EST	Available 03/15/2017 5pm EST	Pending
NS13 - Transfer Crane Girder & Longitudinal Bldg Bracing Dsn	3/27/2017 7:00:00 PM	Handouts	Available 03/29/2017 5pm EST	Available 03/29/2017 5pm EST	Pending
NS13 - Building Envelope and Bracing Design	4/3/2017 7:00:00 PM	Handouts	Available 04/05/2017 5pm EST	Available 04/05/2017 5pm EST	Pending
NS13 - Final Exam	4/10/2017 7:00:00 PM			Available 04/12/2017 5pm EST	

Night School Resources for 8-session package Registrants

- Weekly “quiz and recording” email.
- Weekly updates of the master Quiz and Attendance record found at www.aisc.org/nightschool. Scroll down to Quiz and Attendance records.
 - Updated on Tuesday mornings.



Night School Resources for 8-session package Registrants

- Webinar connection information:
 - Found in your registration confirmation/receipt.
 - Reminder email sent out Monday mornings.
- Link to handouts also found here.



There's always a solution in steel.

Thank You

Please give us your feedback!
Survey at conclusion of webinar.

