

AISC
Night School

Thank you for joining our live webinar today.
We will begin shortly. Please standby.

Thank you.
Need Help?
Call ReadyTalk Support: 800.843.9166

AISC Live Webinars

Today's audio will be broadcast through the internet.

**Alternatively, to hear the audio through the phone,
dial 888-504-7949.**

Passcode: 956659



AISC Live Webinars

Today's live webinar will begin shortly.

Please standby.

As a reminder, all lines have been muted. Please type any questions or comments through the Chat feature on the left portion of your screen.

**Today's audio will be broadcast through the internet.
Alternatively, to hear the audio through the phone, dial
888-504-7949.
Passcode: 956659**



AISC Live Webinars

AISC is a Registered Provider with The American Institute of Architects Continuing Education Systems (AIA/CES). Credit(s) earned on completion of this program will be reported to AIA/CES for AIA members. Certificates of Completion for both AIA members and non-AIA members are available upon request.

This program is registered with AIA/CES for continuing professional education. As such, it does not include content that may be deemed or construed to be an approval or endorsement by the AIA of any material of construction or any method or manner of handling, using, distributing, or dealing in any material or product.

Questions related to specific materials, methods, and services will be addressed at the conclusion of this presentation



AISC Live Webinars

Copyright Materials

This presentation is protected by US and International Copyright laws. Reproduction, distribution, display and use of the presentation without written permission of AISC is prohibited.

© The American Institute of Steel Construction 2017



Course Description

Session 7: November 28, 2017 – Introduction to Seismic Connections

This live webinar provides an overview of seismic connections for engineers that don't typically perform seismic design. Concepts about ductile mechanisms and capacity design are presented. Qualification requirements for special and intermediate moment frame connections will be discussed in addition to an introduction to the nine connection types that have been prequalified. Requirements for concentrically braced frames will be discussed.



Learning Objectives

At the end of this program, participants will be able to:

- Describe the role of ductility in seismic design.
- List design requirements for moment connections specific to seismic design.
- List the steps for the design procedures of a reduced beam section moment connection.
- List the design requirements for bracing connections specific to bracing connections.



There's always a solution in steel.

Fundamentals of Connection Design Session 7: Introduction to Seismic Connections November 28, 2017



Presented by
Matthew Eatherton, Ph.D., S.E.
Associate Professor
Virginia Tech, Blacksburg, Virginia

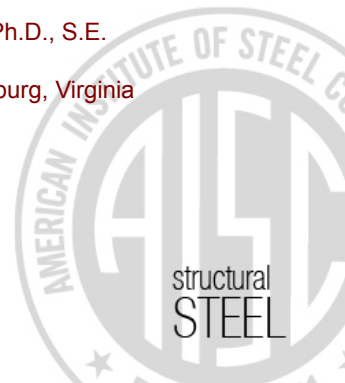

INTRODUCTION TO SEISMIC CONNECTIONS

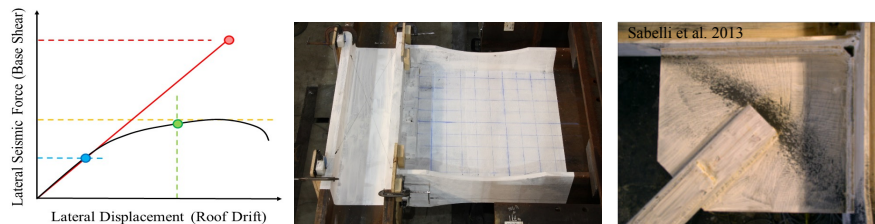

TOPICS

Introduction to Seismic Connections:

- Overview and Basics of Seismic Design
- Special Moment Frame (SMF) Connections
 - AISC 358-16
 - Reduced Beam Section (RBS)
- Special Concentrically Braced Frame (SCBF) Connections
 - Fold Lines
 - Limit States

OVERVIEW AND BASICS OF SEISMIC DESIGN

Audience

- Intended for non-seismic experts

Objectives

- Introductory information
- Schematic examples provided
- Focus on aspects unique to seismic

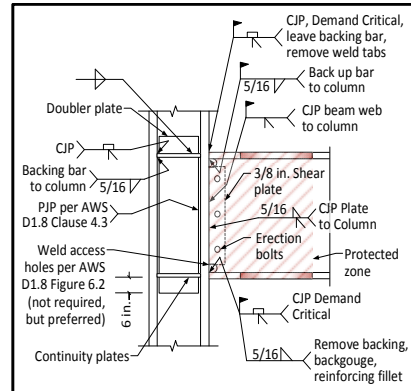

Role of Ductility

Key Concept: Ductility

- Ductility: The ability to deform inelastically without significant loss of strength.
- Buildings survive earthquakes through ductility.
- Buildings deform, dissipate energy, resist collapse.

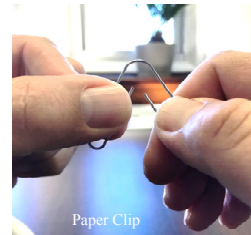

End Plate Moment Connection Subjected to Large Cyclic Deformations

Material vs. Building Ductility

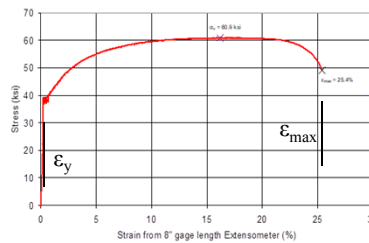

Material Level Ductility:

$$\mu_\epsilon = \frac{\epsilon_{\max}}{\epsilon_y}$$

Typical structural steels:

$$\mu_\epsilon = 100 \text{ to } 200$$

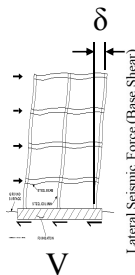

Building Level Ductility:

$$\mu_\delta = \frac{\delta_{\max}}{\delta_y}$$

Typical: $\mu_\delta = 1 \text{ to } 5$

- Ductility of a building is much smaller than material ductility.
- Inelastic strains concentrate and potential for nonductile limit states.
- Try to spread inelasticity, limit deformation concentrations, delay fracture and collapse.



Role of Ductility

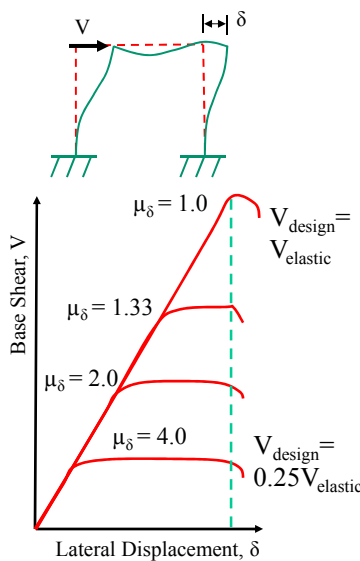

- **Earthquake effects**
 - Earthquakes are more like an applied displacement than an applied force.
- **As System Ductility ↑**
 - ↓ Required Strength
 - ↓ Amount of Materials
 - ↑ Detailing and Connection Cost
- **Economical Buildings**
 - For high seismic, highest ductility system typically wins.
 - For low seismic, not enough reduction in materials.



Design Forces vs. Actual Forces

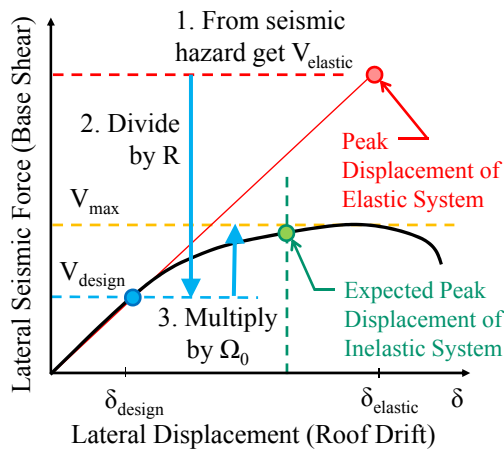

• Design Forces

$$V_{design} = \frac{V_{elastic}}{R}$$

$R =$ Response Modification Factor

• Actual Forces

- Estimate actual base shear:
 $V_{max} = \Omega_0 V_{design}$
- However, many local forces / moments don't scale with Ω_0 .
- Use capacity design.

ASCE 7-16 Ch. 12 Commentary



Ductile Mechanisms

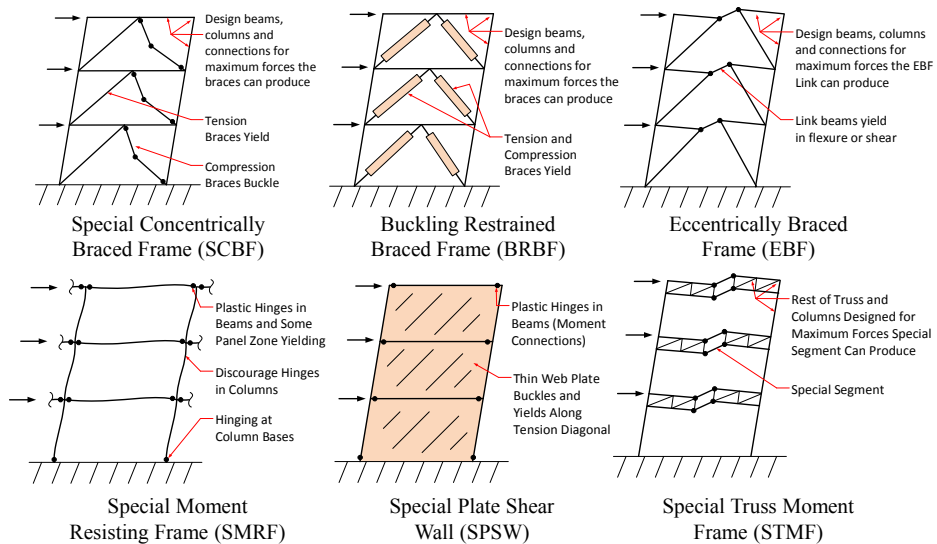

Designing Rest of Load Path

- **Overstrength Factor, Ω_0**
 - Calibrated for base shear ($V_{max} = \Omega_0 V_{design}$)
 - Not all forces / moments scale the same way: ($F_{max} \neq \Omega_0 F_{design}$)

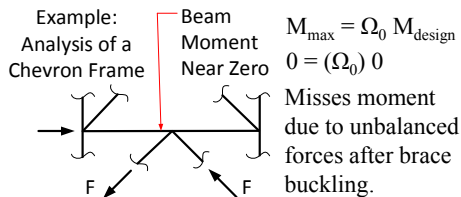

- Allowed for some ordinary systems.

- **Capacity Design**
 - Design for maximum forces the ductile mechanism can produce.
 - May need to consider different scenarios.

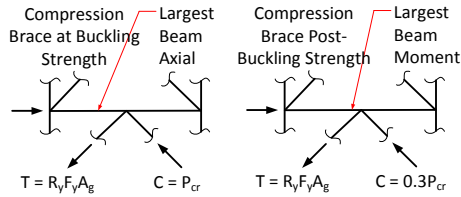

- Required for most systems in Seismic Provisions

Necessary References

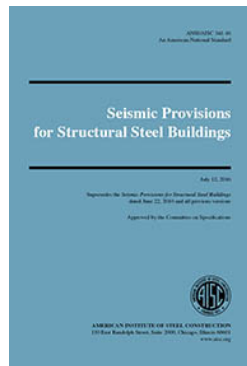

AISC 341-16
Seismic Provisions

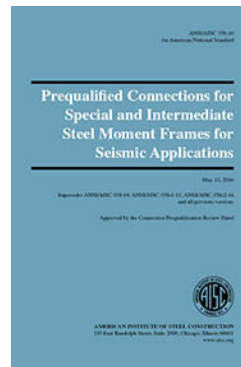

AISC 358-16
Prequalified Connections

Free download from: www.aisc.org/publications/steel-standards/

Expected Strength of Ductile Mechanism

- Expected yield stress, $F_{y-expected} = R_y F_y$
 – Table A3.1 in AISC 341-16 (Excerpt)

Application	R_y	R_t
Hot-rolled structural shapes and bars:		
• ASTM A36/A36M	1.5	1.2
• ASTM A1043/A1043M Gr. 36 (250)	1.3	1.1
• ASTM A992/A992M	1.1	1.1
• ASTM A572/A572M Gr. 50 (345) or 55 (380)	1.1	1.1
• ASTM A913/A913M Gr. 50 (345), 60 (415), 65 (450), or 70 (485)	1.1	1.1
• ASTM A588/A588M	1.1	1.1
• ASTM A1043/A1043M Gr. 50 (345)	1.2	1.1
• ASTM A529 Gr. 50 (345)	1.2	1.2
• ASTM A529 Gr. 55 (380)	1.1	1.2
Hollow structural sections (HSS):		
• ASTM A500/A500M Gr. B	1.4	1.3
• ASTM A500/A500M Gr. C	1.3	1.2

Role of Connections

- Role of Connections in Seismic Design**
 - Ductility is intimately tied to connection detailing.
 - Based on tests.
 - Types of requirements: materials, geometry, weld detailing, surface roughness, etc.
- Focus for This Session**
 - Seismic Provisions include OMF, IMF, SMF, STMF, OCCS, SCCS, OCBF, SCBF, EBF, BRBF, SPSW, Composite.
 - Focus on two common systems:
 - Special moment frames (SMF)
 - Special concentrically braced frames (SCBF)

SPECIAL MOMENT FRAME (SMF) CONNECTIONS

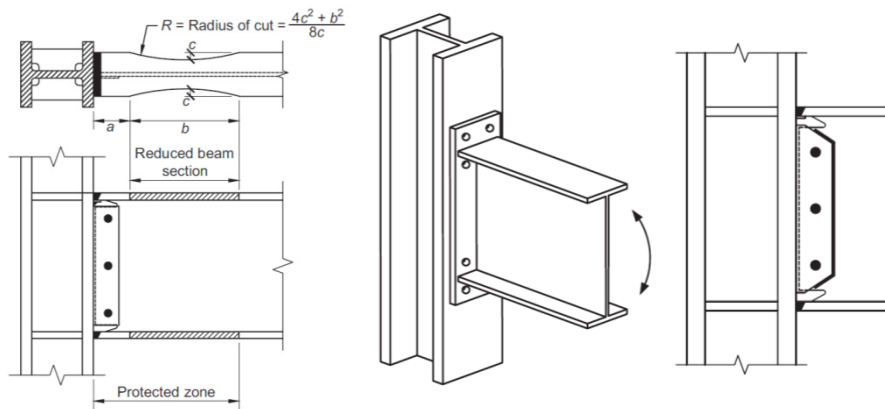

Northridge Earthquake Fractures

- **Description**
 - January 17, 1994 Northridge Eq. $M_w = 6.7$
 - Hundreds of MRF buildings had fractures
 - January 17, 1995 Kobe Eq. $M_w = 6.9$ - Similar fractures
- **Pre-Northridge Moment Connections**
 - Fracture typically occurred at bottom flange.

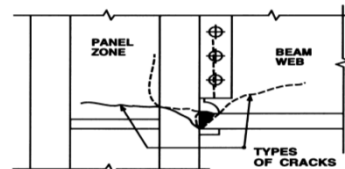
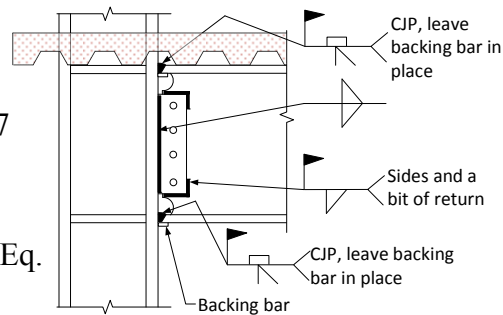
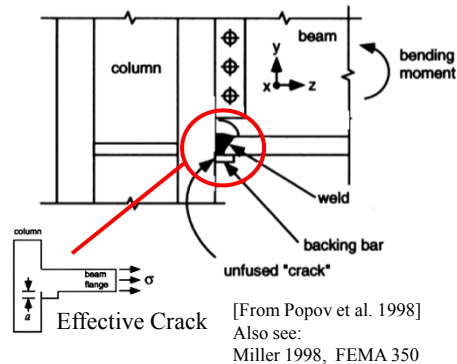

Figure 2 Some failure modes of the welded beam-to-column connection [From Popov et al. 1998]

Northridge Fractures - Causes

- Contributing Factors**

1. Backing bar at bottom flange – effective crack.
2. Weld quality poor at bottom flange root and starts / stops at middle.
3. Composite slab shifts neutral axis up – larger strains at bottom flange.
4. Weld access hole geometry.
5. Weld filler material low toughness.
6. Panel zones were weaker.



- Implications**

- SMF and IMF connections must be tested at full scale.
- Pass qualification criteria.

Overview of SMF Design

- Primary Checks**

1. Drift (ASCE 7-16)
2. Connection capable of 0.04 rad story drift (§E3.6b/c)
3. Highly ductile section for beams and columns (§E3.5a)
4. Strong Column Weak Beam (Moment Ratio) (§E3.4a)
5. Shear strength of connection (§E3.6d)
6. Panel zone shear (§E3.6e)
7. Continuity plates (§E3.6f)

Will Discuss Today

- Additional Requirements**

1. Bracing of Beams (§E3.4b)
2. Shared columns in orthogonal frames (§E3.3)
3. Protected Zone (§E3.5c)
4. Demand Critical Welds (§E3.6a)
5. Column splices (§E3.6g)
6. Clear span to depth ratio for beams (AISC 358)

Sections cited are in AISC 341-16

SMF Connection Conformance

- **Requirement (§E3.6b)**
 1. Full-scale tests.
 2. Cyclic loading up to story drift of 0.04 rad.
 3. Must retain moment strength of $0.80 M_p$ (nominal).
- **Ways to Show Conformance**
 1. Use a connection in AISC 358-16 (prequalified).
 2. Use a connection prequalified by someone else.
 3. Conduct two qualifying tests identical to your building.

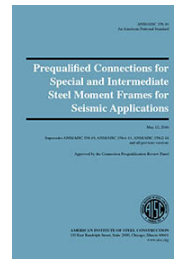

AISC 358-16
 Ductile Limit State, $\phi_d = 1.0$
 Nonductile Limit State, $\phi_n = 0.9$



Qualification Testing



AISC 358-16 Prequalified Conn. 1/3

Each connection has its own limits on prequalification.

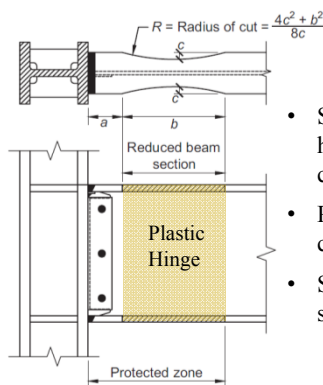

- Shifts plastic hinge away from column face.
- Protects beam-to-column welds.
- Slight reduction in stiffness.

1. Reduced Beam Section (RBS)

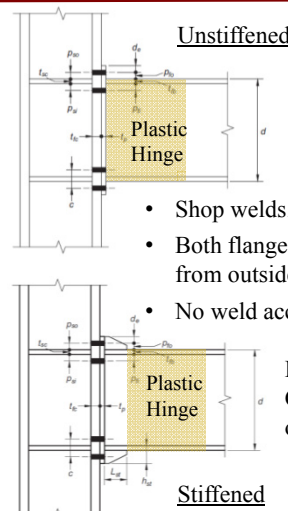

- Shop welds.
- Both flanges welded from outside face.
- No weld access holes.

Beam flange CJP, but PJP over web.

2. End-Plate Connections



AISC 358-16 Prequalified Conn. 2/3

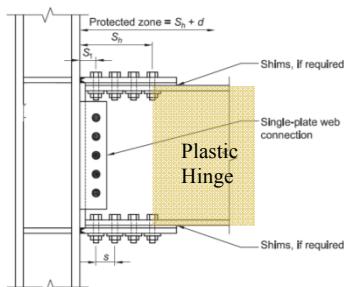

- Plastic hinge shifts away from welds.
- Slip of flange plate bolts occurs.
- Flange plates shop welded to column.

3. Bolted Flange Plate

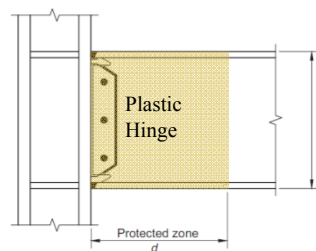

- Allows plastic hinge up to face of column.
- Special weld access hole geometry.
- Special detailing requirements for beam weld to column.

4. Welded Unreinforced Flange – Welded Web (WUF-W)

AISC 358-16 Prequalified Conn. 3/3

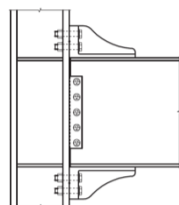

5. Kaiser Bolted Bracket

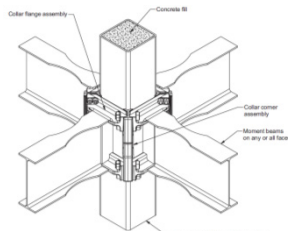

6. ConXtech® ConXL™

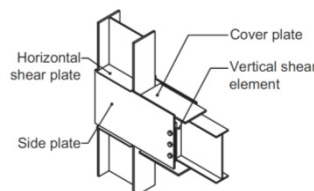

7. Side Plate®

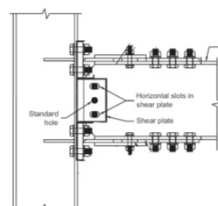

8. Simpson Strong-Tie® Strong Frame®

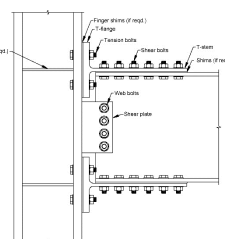

9. Double-Tee

Highly Ductile Members

- Section Compactness (*Provisions §D1.1*)

- Delay local buckling.
- §E3.5a requires highly ductile section for beams and columns.
- Also bracing requirements.

Flanges of I-Shape

$$\frac{b_f}{2t_f} \leq 0.32 \sqrt{\frac{E}{R_y F_y}}$$

Web of I-Shape

If $C_a \leq 0.114$

If $C_a > 0.114$

$$\frac{h}{t_w} \leq 2.57 \sqrt{\frac{E}{R_y F_y}} (1 - 1.04 C_a) \quad \frac{h}{t_w} \leq \left[0.88 \sqrt{\frac{E}{R_y F_y}} (2.68 - C_a) \geq 1.57 \sqrt{\frac{E}{R_y F_y}} \right]$$

$$C_a = \frac{P_u}{\phi_c P_y}$$

$$P_y = R_y F_y A_g$$

$F_y \text{ expected} = R_y F_y$
 Table A3.1 in AISC 341-16
 $R_y = 1.1$ for A992



Note: Presenting LRFD only,
 not showing ASD version of C_a



29

Highly Ductile Members - Example

- Determine if the following section is highly ductile

A992 W24x62 with axial force $P_u = 100$ kips to be used as SMF Beam.

$$\frac{b_f}{2t_f} = 5.97 \quad \frac{h}{t_w} = 50.1 \quad A = 18.2 \text{ in}^2 \quad \text{From Table 1-1 in the Manual.}$$

- Check Flanges:

$$0.32 \sqrt{\frac{E}{R_y F_y}} = 0.32 \sqrt{\frac{29,000 \text{ ksi}}{(1.1)(50 \text{ ksi})}} = 7.35$$

$$\left[\frac{b_f}{2t_f} = 5.97 \right] \leq \left[0.32 \sqrt{\frac{E}{R_y F_y}} = 7.35 \right] \quad \text{Flanges satisfy highly ductile limit.}$$



30

Highly Ductile Members - Example

– Check Web: A992 W24x62 with $P_u = 100$ kips

$$C_a = \frac{P_u}{\phi_c P_y} = \frac{P_u}{\phi_c R_y F_y A_g} = \frac{100 \text{ kips}}{0.9(1.1)(50 \text{ ksi})(18.2 \text{ in}^2)} = 0.111$$

Since $C_a \leq 0.114$

$$2.57 \sqrt{\frac{E}{R_y F_y}} (1 - 1.04 C_a) = 2.57 \sqrt{\frac{29,000 \text{ ksi}}{(1.1)(50 \text{ ksi})}} [1 - 1.04(0.111)] = 52.2$$

$$\left[\frac{h}{t_w} = 50.1 \right] \leq 52.2 \quad \text{Web satisfies highly ductile limit.}$$

Section satisfied highly ductile compactness criteria

– Table 1-3 in AISC Seismic Manual shows this also.

Strong-Column-Weak-Beam (SCWB)

• **Moment Ratio (Provisions §E3.4a)**

- Project the beam and column moments to center of connection.
- Sum of column moments should be greater.
- Force the beam plastic hinges to occur at multiple levels.

$$\frac{\sum M_{pc}^*}{\sum M_{pb}^*} > 1.0$$

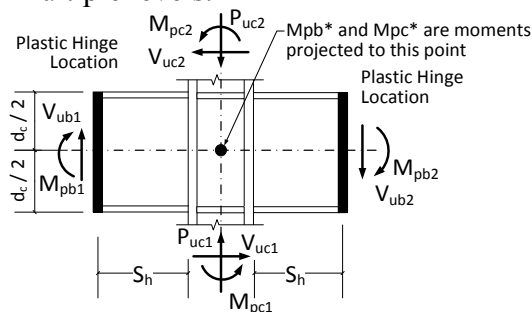

S_h is distance to plastic hinge. See AISC 358.

- $S_h = a + b/2$ for RBS.
- $S_h = \min\{d/2, 3b_{bf}\}$ for Unstiff End Plate.
- $S_h =$ end of stiffener in Stiffened End Plate.
- $S_h = 0$ for WUF-W.

Strong-Column-Weak-Beam (SCWB)

- Beam Moment**

$$M_{pr} = C_{pr} R_y F_y Z_e \quad \text{Eqn. (2.4-2)}$$

$$C_{pr} = \frac{F_y + F_u}{2F_y} \leq 1.2 \quad \text{Typical unless otherwise specified in AISC 358.}$$

$$C_{pr} = 1.4 \quad \text{for WUF-W}$$

Z_e = effective plastic section modulus

V_{ub} = Shear due to plastic hinging + Shear due to gravity loads

$$V_{ub} = \frac{2M_{pr}}{L_h} + V_{u \text{ gravity}}$$

$$M_{pb}^* = M_{pr} + V_{ub} \left(\frac{d_c}{2} + S_h \right)$$

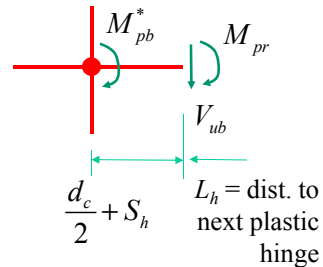

Note: Presenting LRFD only,
neglecting α_s term for ASD



33

Strong-Column-Weak-Beam (SCWB)

- Column Moment**

$$M_{pc} = Z_c \left(F_{yc} - \frac{P_{uc}}{A_g} \right)$$

$$M_{pc}^* = M_{pc}$$

- Does not use expected yield stress, $R_y F_y$.
- Does not use strain hardening factor, C_{pr} .
- Can neglect additional moment due to column shear, $V_c d_b / 2$

- Moment Ratio**

$$\frac{\sum M_{pc}^*}{\sum M_{pb}^*} > 1.0$$

- Sum for all beams and columns framing into joint.



34

SCWB Example

- Determine if strong-column-weak-beam is satisfied

– Beam Moment

$$C_{pr} = \frac{F_y + F_u}{2F_y} = \frac{50 \text{ ksi} + 65 \text{ ksi}}{2(50 \text{ ksi})} = 1.15 < 1.2$$

$$R_y = 1.1 \quad \text{Table A3.1 for A992}$$

$$Z_x = 581 \text{ in}^3 \quad \text{for W36x150}$$

$$M_{pr} = C_{pr} R_y F_y Z_x$$

$$M_{pr} = (1.15)(1.1)(50 \text{ ksi})(581 \text{ in}^3)$$

$$M_{pr} = 36,750 \text{ k-in.}$$

Stiffened Extended End-Plate Connection

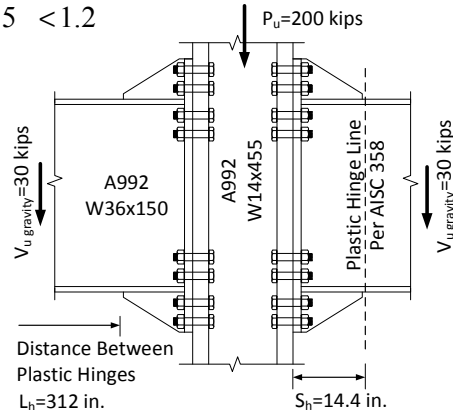

SCWB Example

- Determine if strong-column-weak-beam is satisfied

– Beam Moment

$$V_{ub} = \frac{2M_{pr}}{L_h} + V_{u \text{ gravity}} = \frac{2(36,750 \text{ k-in.})}{(312 \text{ in.})} + 30 \text{ kips} = 265 \text{ kips}$$

$$M_{pb}^* = M_{pr} + V_{ub} \left(\frac{d_c}{2} + S_h \right)$$

$$M_{pb}^* = (36,750 \text{ k-in.}) + (265 \text{ kips}) \left(\frac{19.0 \text{ in.}}{2} + 14.4 \text{ in.} \right) = 43,100 \text{ k-in.}$$

$$\sum M_{pb}^* = (2 \text{ beams})(43,100 \text{ k-in.}) = 86,200 \text{ k-in.}$$

SCWB Example

- Determine if strong-column-weak-beam is satisfied

– Column Moment

$$Z_x = 936 \text{ in}^3 \text{ and } A = 134 \text{ in}^2 \text{ for W14x455}$$

$$P_{uc} = P_u + 2V_{u \text{ gravity}} = 200 \text{ kips} + 2(30 \text{ kips}) = 260 \text{ kips}$$

$$M_{pc}^* = Z_c \left(F_{yc} - \frac{P_{uc}}{A_g} \right) = (936 \text{ in}^3) \left(50 \text{ ksi} - \frac{260 \text{ kips}}{134 \text{ in}^2} \right) = 45,000 \text{ k-in.}$$

$$\sum M_{pc}^* = (2 \text{ columns})(45,000 \text{ k-in.}) = 90,000 \text{ k-in.}$$

– Moment Ratio

$$\frac{\sum M_{pc}^*}{\sum M_{pb}^*} = \frac{90,000 \text{ k-in.}}{86,200 \text{ k-in.}} = 1.04 > 1.0$$

Strong-Column-Weak-Beam is Satisfied.

Column Panel Zone Shear

- Requirement

Provisions

§E3.6e

$$R_u \leq \phi R_n$$

$$\phi_v = 1.0$$

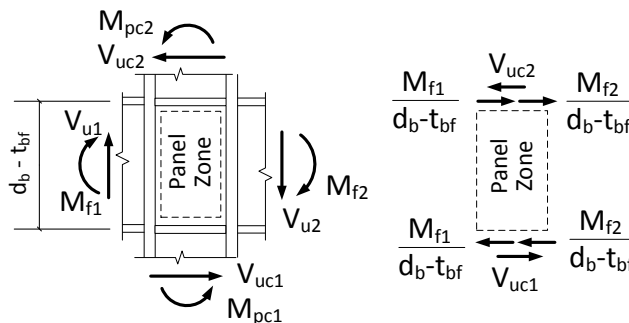

- Demand (Required Strength) Moment at Face of Column

$$R_u = \sum \frac{M_f}{d_b - t_{bf}} - V_c$$

Column shear is always opposing beam flange forces.

$$M_f = M_{pr} + V_{ub} S_h$$

$$\text{Column Shear: } V_c \cong \frac{\sum M_f}{\frac{h_{above}}{2} + \frac{h_{below}}{2}}$$

Column Panel Zone Shear

- **Design Panel Zone Strength**
 - Specification §J10.6
 - If panel zone is considered in frame stability and $P_r \leq 0.75 P_e$
- **Doubler Plates §E3.6e**
 - Get ϕR_n using:

$$t_w = t_{wc} + t_{dp}$$
 - Minimum thickness of column web or doubler plates:

$$t \geq \frac{d_z + w_z}{90} \quad \begin{matrix} d_z = d_b - 2t_{fb} \\ w_z = d_c - 2t_{fc} \end{matrix}$$

$$R_n = \underbrace{(0.6F_y)}_{\text{Plastic shear strength}} d_c t_w \underbrace{\left(1 + \frac{3b_{cf} t_{cf}^2}{d_b d_c t_w}\right)}_{\text{Increase for column flanges}} \quad (\text{J10-11})$$

- If $R_u \leq \phi R_n$ then done.
- If $R_u > \phi R_n$ then add doubler plates.

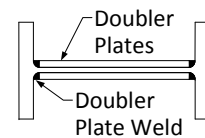

- Also detailing (§E3.6e(3))

Continuity Plates (Column Web Stiffeners)

- **Continuity Plates (§E3.6f)**
 - Provide continuity plates if either of the following:
 - (a) Required by Section J10 of Specification using force: $P_f = M_f / (d_b - t_{fb})$
reduce by 0.85 if welded web
 - (b) Column flange thickness less than t_{lim}
 - Follow detailing in Specification J10.8 and Seismic Provisions E3.6f.2.

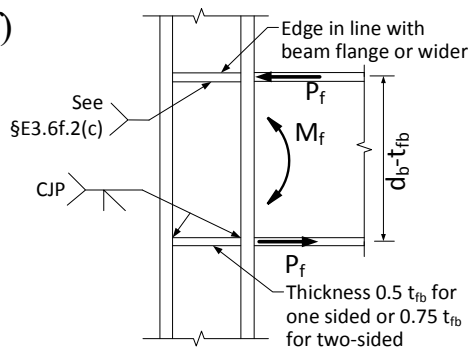

↻

$$t_{lim} = \frac{b_{bf}}{6} \quad \text{For beam welded to flange of W shape or built-up I}$$

Demand Critical Welds

- **Locations** (§E3.6a)
 - Welds where inelastic strains are expected.
 - Beam-to-column, column splices, column-to-base plate (with exceptions), others as specified in AISC 358.
- **Requirements** (§A3.4b and AWS D1.8)
 - Specify demand critical welds on drawings.
 - Filler metals must have high elongation and CVN toughness.

For E70: Elongation > 22%
 CVN toughness > 20 ft-lb at 0° F

Protected Zone

- **Locations** (AISC 358)
 - Where inelastic strains are expected.
 - Different for each connection (see AISC 358).
- **Requirements** (§I2.1)
 - No tack welds, holes, erection aids, arc gouging, thermal cutting, headed shear studs.
 - No welded, bolted, screwed, or power-actuated fasteners.
 - Exception: arc spot welds and PAF for decking attachments.

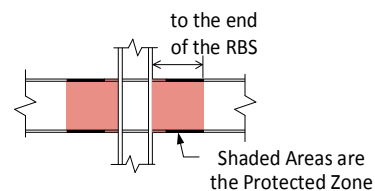

Reduced Beam Section Connection

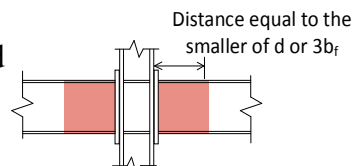

Unstiffened Extended End-Plate Connection

Reduced Beam Section (RBS)

- **Learning Objective**
 - Understand and apply design procedure for one prequalified connection type.
- **Prequalification Limits (§5.3)**
 - Design to conform to limits of what has been tested.
 - Beams:
 - Maximum of W36
 - Weight ≤ 302 lb/ft,
 - $t_f \leq 1.75$ in.
 - Clear span to depth ≥ 7 (SMF)
 - W shape or equivalent built-up section
 - Columns:
 - Beam connects to column flange
 - Maximum of W36 or equivalent built-up
 - Up to 24 in. box section

Reduced Beam Section (RBS)

- **Special Requirements**
 - Allows smaller b_f in highly ductile member check (§5.3.1(6)).
 - SCWB - Calculates M_{pr} based on Z_{RBS} (§5.4(2)).
 - Use elastic drift x 1.1 for $c = 0.25b_{bf}$, interpolate for less (§5.8-1).
- **Design Procedure (§5.8)**
 - Step 1. Choose a, b, c

$$0.5b_{bf} \leq a \leq 0.75b_{bf}$$

$$0.65d \leq b \leq 0.85d$$

$$0.1b_{bf} \leq c \leq 0.25b_{bf}$$

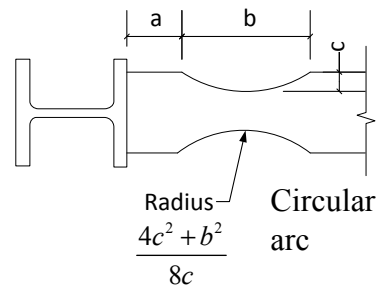

Reduced Beam Section (RBS)

- **Design Procedure (§5.8)**

- Step 2. Plastic section modulus at center of RBS, Z_{RBS}

$$Z_{RBS} = Z_x - 2ct_{bf}(d - t_{bf})$$

- Step 3. Calculate probable maximum moment, M_{pr}

$$M_{pr} = C_{pr} R_y F_y Z_{RBS}$$

- Step 4. Calculate shear force at RBS, V_{RBS}

$$V_{RBS} = \frac{2M_{pr}}{L_h} + V_{u \text{ gravity}} \quad L_h = \text{distance between plastic hinges (center of RBS's)}$$

- Step 5. Calculate beam moment at face of column, M_f

$$M_f = M_{pr} + V_{RBS} S_h \quad S_h = a + \frac{b}{2}$$

Reduced Beam Section (RBS)

- **Design Procedure (§5.8)**

- Step 6. Calculate plastic moment strength of beam (strength at face of column neglecting access holes)

$$M_{pe} = R_y F_y Z_x$$

- Step 7. Check flexural strength of beam at face of column

$$M_f \leq \phi_d M_{pe} \quad \phi_d = 1.0 \text{ for ductile limit states}$$

- Step 8. Check shear strength of beam

$$V_u = \frac{2M_{pr}}{L_h} + V_{u \text{ gravity}} \quad \text{Shear Strength per Specification Ch. G}$$

Reduced Beam Section (RBS)

- **Design Procedure (§5.8)**
 - Step 9. Beam web weld to column flange – detailing per (§5.6)
 - Step 10. Check for continuity plates, design if necessary
 - Step 11. Strong-Column-Weak-Beam requirement
 - Other. Column panel zone shear
 - Other. Detailing requirements in AISC 358

Reduced Beam Section Example

- **Step 0 – Prequalification Limits (§5.3)**
 - Beams are W36 or smaller, not more than 302 lb/ft, and $t_{bf} \leq 1.75$ in. **OK**
 - Clear span / depth greater than or equal to 7 (394 in. / 24.1 in. = 16.3) **OK**
 - Sections are highly ductile **OK** (Seismic Manual Table 1-3)
 - Column is less than W36 **OK**

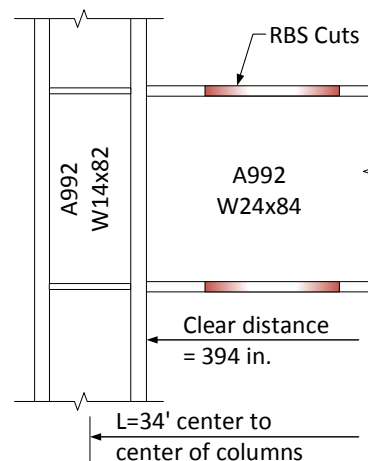

Reduced Beam Section Example

- Step 1 – Trial Values for a, b, c

$$b_{bf} = 9.02 \text{ in. and } d = 24.1 \text{ in. for W24x84}$$

$$[0.5b_{bf} = 4.51 \text{ in.}] \leq a \leq [0.75b_{bf} = 6.76 \text{ in.}]$$

$$[0.65d = 15.7 \text{ in.}] \leq b \leq [0.85d = 20.5 \text{ in.}]$$

$$[0.1b_{bf} = 0.90 \text{ in.}] \leq c \leq [0.25b_{bf} = 2.25 \text{ in.}]$$

Select:

$$a = 6.00 \text{ in.}$$

$$b = 18.0 \text{ in.}$$

$$c = 2.0 \text{ in.}$$

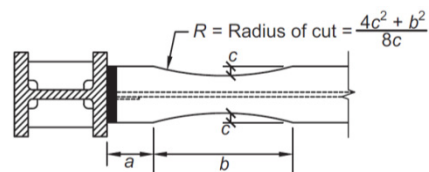
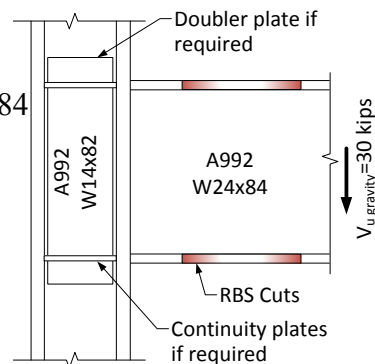

Reduced Beam Section Example

- Step 2 – Calculate Z_{RBS}

$$Z_{RBS} = Z_x - 2ct_{bf}(d - t_{bf})$$

$$Z_{RBS} = 224 \text{ in}^3 - 2(2.0 \text{ in.})(0.77 \text{ in.})(24.1 \text{ in.} - 0.77 \text{ in.}) = 152 \text{ in}^3$$

- Step 3 – Calculate M_{pr}

$$C_{pr} = \frac{F_y + F_u}{2F_y} = \frac{50 \text{ ksi} + 65 \text{ ksi}}{2(50 \text{ ksi})} = 1.15 < 1.2$$

$$R_y = 1.1 \text{ Table A3.1 for A992}$$

$$M_{pr} = C_{pr} R_y F_y Z_{RBS}$$

$$M_{pr} = (1.15)(1.1)(50 \text{ ksi})(152 \text{ in}^3)$$

$$M_{pr} = 9610 \text{ k-in.}$$

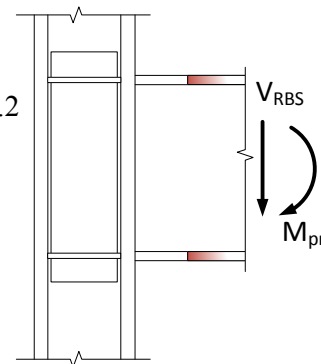

Reduced Beam Section Example

- Step 4 – Shear at Center of RBS

$$S_h = a + \frac{b}{2} = 6 \text{ in.} + \frac{18 \text{ in.}}{2} = 15 \text{ in.}$$

$$L_h = L - d_c - 2S_h$$

$$L_h = 408 \text{ in.} - 14.3 \text{ in.} - 2(15 \text{ in.}) = 364 \text{ in.}$$

$$V_{RBS} = 2M_{pr} / L_h + V_{u \text{ gravity}}$$

$$V_{RBS} = \frac{2(9610 \text{ k-in.})}{364 \text{ in.}} + 30 \text{ kips} = 83 \text{ kips}$$

- Step 5 – Calculate M_f

$$M_f = M_{pr} + V_{RBS} S_h$$

$$M_f = 9610 \text{ k-in.} + (83 \text{ kips})(15 \text{ in.}) = 10,860 \text{ k-in.}$$

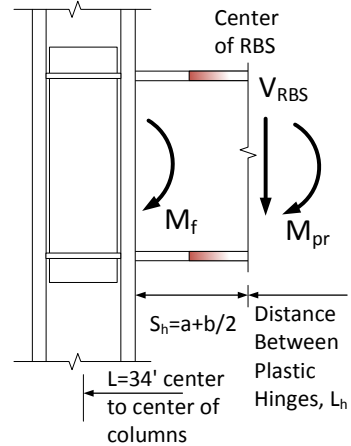

Reduced Beam Section Example

- Step 6 – Calculate Moment Strength at Column Face

$$M_{pe} = R_y F_y Z_x$$

$$M_{pe} = (1.1)(50 \text{ ksi})(224 \text{ in}^3)$$

$$M_{pe} = 12,320 \text{ k-in.}$$

W24x84 beam
 $Z_x = 224 \text{ in}^3$

- Step 7 – Check Moment Strength at Face

$$\phi_d M_{pe} \geq M_f \quad \phi_d = 1.0 \text{ for ductile limit states per 358}$$

$$\phi_d M_{pe} = (1.0)12,320 \text{ k-in.} = 12,320 \text{ k-in.}$$

$$[\phi_d M_{pe} = 12,320 \text{ k-in.}] \geq [M_f = 10,860 \text{ k-in.}]$$

Beam Moment Strength at Column Face is Sufficient

Reduced Beam Section Example

- Step 8 – Check Beam Shear Strength**

$$V_u = V_{RBS} = 83 \text{ kips}$$

- Difference is gravity load between RBS and column face.
- Conservatively include in both.

– *Specification* Chapter G

$$\frac{h}{t_w} \leq 2.24 \sqrt{\frac{E}{F_y}} \quad \Rightarrow \quad 45.9 \leq 53.9 \quad \text{So, } \phi_v = 1.0 \text{ and } C_{v1} = 1.0$$

$$\phi_v V_n = \phi_v 0.6 F_y A_w C_{v1} = (1.0)(0.6)(50 \text{ ksi})[(24.1 \text{ in.})(0.47 \text{ in.})](1.0)$$

$$\phi_v V_n = 340 \text{ kips} \quad \text{Eqn. (G2-1)}$$

$$[\phi_v V_n = 340 \text{ kips}] \geq [V_u = 83 \text{ kips}]$$

Beam Shear Strength at Column Face is Sufficient

Reduced Beam Section Example

- Step 9 – Beam Web to Column Weld**

- Beam web to Column Flange is CJP.
- Detailing per (§5.6) – 3/8 in. shear tab as weld backing.

- Step 10 – Continuity Plates see AISC 341 §E3.6f**

- Check *Specification* §J10 with concentrated force, P_f

$$P_f = \frac{0.85 M_f}{d - t_{bf}} = \frac{0.85(10,860 \text{ k-in.})}{24.1 \text{ in.} - 0.77 \text{ in.}} = 396 \text{ kips} \quad \begin{array}{l} \text{Eqn from AISC 341} \\ \text{E3.6f for welded web} \end{array}$$

- Also need continuity plates if: $t_{cf} < t_{c,lim}$ $t_{cf} = 0.855 \text{ in.}$

$$t_{c,lim} = \frac{b_{bf}}{6} = \frac{9.02 \text{ in.}}{6} = 1.50 \text{ in.} \quad t_{cf} \leq t_{c,lim} \quad \begin{array}{l} \text{Continuity Plates} \\ \text{are Required} \end{array}$$

- Follow reqmnts: AISC 341 §E3.6f.2 and AISC 360 § J10.8

Reduced Beam Section Example

- **Step 11 – Strong-Column-Weak-Beam**
 - Satisfied (not shown here - already worked an example).
- **Panel Zone Shear AISC 341 §E3.6e**
 - Find that 1/2 in. doubler plate required (not shown here, see example in previous session).
 - Individual layers (web and doubler) minimum thickness:

$$t \geq \frac{d_z + w_z}{90} = \frac{(d - 2t_{bf}) + (d_c - 2t_{cf})}{90} = 0.390 \text{ in.}$$

$$[t_{wc} = 0.51 \text{ in}] \geq 0.390 \text{ in.}$$

$$[t_{doubler} = 0.50 \text{ in}] \geq 0.390 \text{ in.}$$

OK

W14x82 column

- Follow detailing requirements in AISC 341 §E3.6e.3.

Reduced Beam Section Example

- **Final Detailing**

AISC 358 §3.3

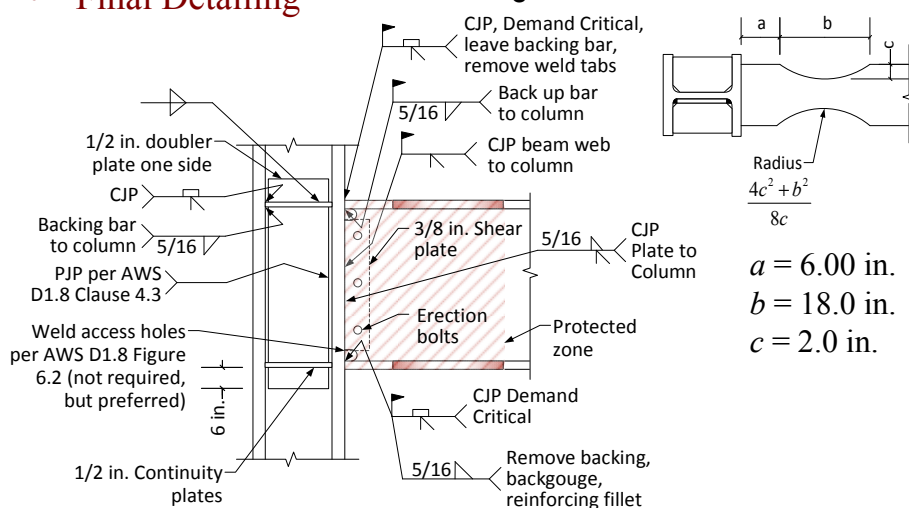

SPECIAL CONCENTRICALLY BRACED FRAME CONNECTIONS

Back in AISC 341-16 now

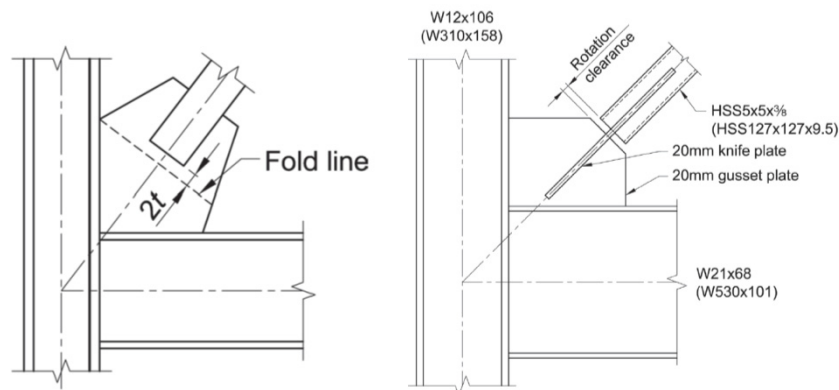

Introduction to SCBF Connections

- Unique Issues for Seismic Bracing Connections

1. Accommodating rotation in braces – either accommodate rotation or push plastic hinge into brace.
2. Beam-to-column connections with bracing gussets – design as simple shear or as moment connection.
3. Designing bracing connections for expected tension strength of braces.
4. Net section area $>$ gross section area.
5. Demand critical welds.
6. Protected zone.

Member requirements not listed.

Accommodating Brace Rotation

- **Member requirements (not covered here):**
 - Braces in alternating directions – tension and compression.
 - Required strength for columns and beams: combinations of brace tension yielding, buckling strength, brace post-buckling strength.
 - Columns, beams and braces satisfy highly ductile criteria.
- **Bracing Connection**
 - Ductile mechanism is brace yielding and brace buckling.
 - Must accommodate brace rotation as it buckles without fracture (§F2.6c.3).

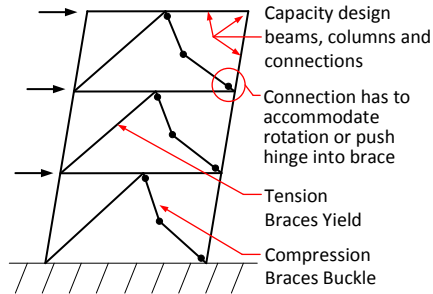

Accommodating Brace Rotation

- Line perpendicular to brace centerline, start at gusset intersection nearest brace end.

t = thickness of gusset plate

Fold line

$2t$

 - **2t Fold Line**
 - Provide a hinge zone in the gusset plate, width $2t$.
 - Gusset plate buckling may control gusset thickness.

t_p = thickness of knife plate

Rotation clearance

$3t_p$ rotation clearance

Knife plate

 - **Knife Plate Detail**
 - In-plane brace buckling.
 - Provide a hinge zone in the knife plate, width $3t_p$.
 - More compact connection.

See Seismic Design Manual for Examples

Accommodating Brace Rotation

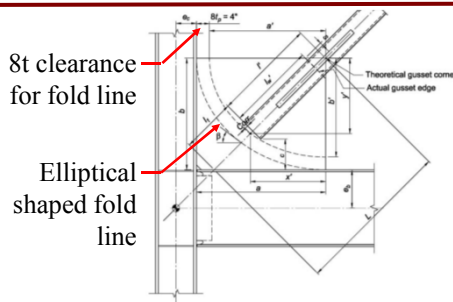

- **Elliptical Fold Line**

- Provide an elliptical hinge zone in the gusset, width $8t$.
- Generally more compact than straight $2t$ fold line.

See Seismic Design Manual for Example

- Push plastic hinge into brace
- Section §F2.6c.3(a) – design brace connection for expected brace flexural strength x 1.1.
- $1.1R_yM_p$ of brace about the critical buckling direction.
- Less common than accommodating rotation in gusset per §F2.6c.3(b).



Note: Presenting LRFD only,
 neglecting α_s term for ASD



61

Beam-to-Column Connections

- §F2.6b - Option (a)
- Design as simple connection. Allow rotation per Specification §B3.4a.
- Commentary shows three options:

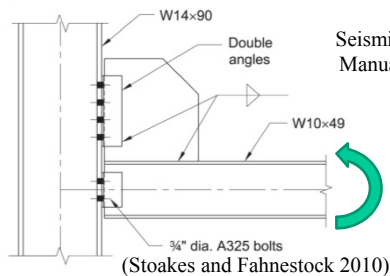

(Stoakes and Fahnestock 2010)

See Example 5.3.10 in Seismic Design Manual 2nd Ed.

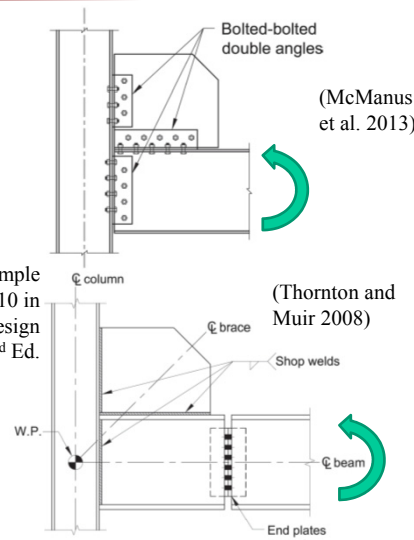

(McManus et al. 2013)

(Thornton and Muir 2008)



62

Beam-to-Column Connections

- §F2.6b - Option (b)

- Design as moment connection.
- Design for either expected flexural strength of beam x 1.1, or 1.1 times sum of expected flexural strength of columns framing into joint.
- Combine with demands from brace and collector.
- See Example 5.3.12 in 2nd Ed. Seismic Design Manual.

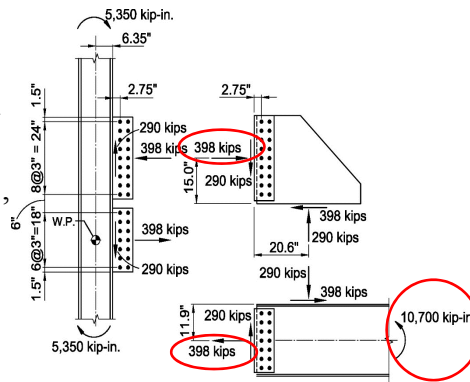

*Example of loads associated with required moment
 2nd Ed. SDM Ex. 5.3.12*

Beam-to-Column Connections

- §F2.6b - Option (c)

- Detail similar to WUF-W, see §E1.6b(c).
- Welds per AISC 358 with CJP at flanges.
- Special weld access hole detailing.
- Beam web to column welded or single plate bolted.
- Continuity plates per E3.6f.

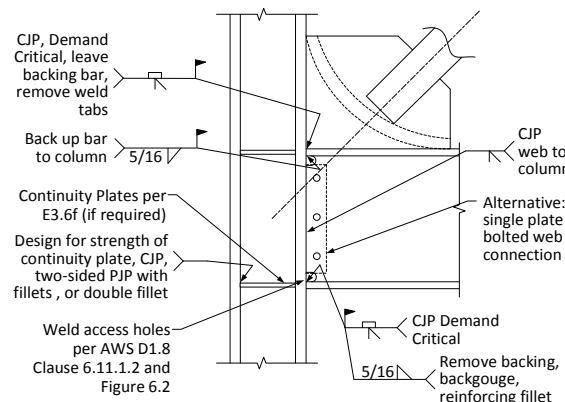

Connection Demands - Tension

- Required Tensile Strength §F2.6c.1

- $T_u = R_y F_y A_g$ A_g = gross area of brace
- This load does not apply to brace net section check.
- Can be limited by the max force that can be transferred to brace (e.g. foundation uplift) – not common and not a good design approach.
- For standard size holes, don't need to design as slip critical. For oversized holes, design demand for slip can be limited by overstrength loads.

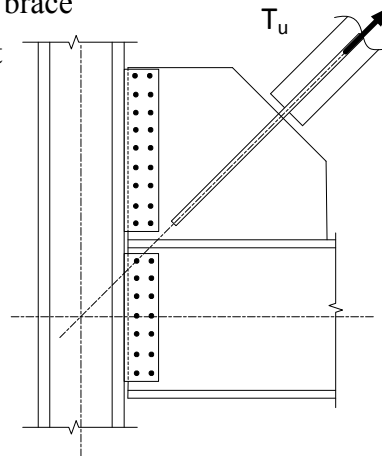

Connection Demands - Compression

- Required Compression Strength, §F2.6c.2

- Design connection for expected brace strength in compression (see below).
- Does not need to exceed $R_y F_y A_g$.
- Length used in buckling calculation not greater than brace end to brace end.

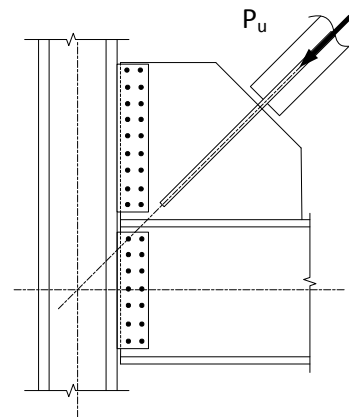

$$P_u = \frac{F_{cre} A_g}{0.877}$$

$F_{cre} = F_{cr}$ from Specification Ch. E, but using $R_y F_y$ as yield

Connection Demands - Flexure

- **Required Flexural Strength, §F2.6c.3**
 - If not detailing connection to accommodate rotation.
 - $M_u = 1.1 R_y M_p$ of brace
- **Combination of Tension, Compression, and Flexure**
 - Permitted to consider loads independently, no interaction.
 - See beginning of §F2.6c.

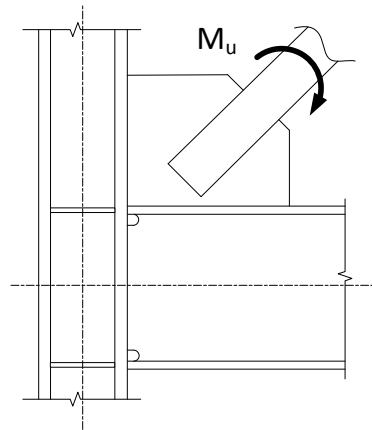

Overview of Limit States

1. Brace net section fracture - Unique to SCBF
2. Brace to knife plate weld
3. Knife plate tension yielding, net section rupture, compression buckling
4. Knife plate to gusset weld
5. Gusset tension yield on Whitmore section, compression buckling
6. Gusset at bolts – tension yield, net section tension rupture, shear rupture, block shear
7. Gusset to beam weld
8. Shear transfer at single plate connections: (bolt shear, bearing and tear-out)
9. Single plates - tension yield, net section tension or shear rupture, block shear

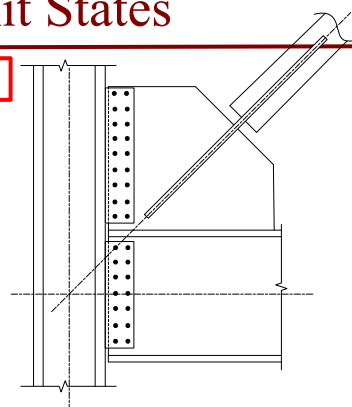

10. Single plates to column weld
11. Beam web local yielding and crippling / stiffeners if necessary
12. Column web local yielding and crippling / stiffeners if necessary

Net Section Fracture Requirement

- **Brace Net Area, §F2.5b.(c)**

- Brace effective net area not less than gross area.
- For knife plate connection, slot in brace can be close to end of knife plate.
- AWS D1.1-10 §5.22 says root opening not greater than 3/16 in. and if over 1/16 in. increase legs of fillet for root opening size.

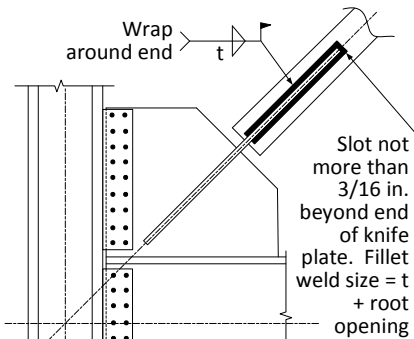

One approach for making net area \geq gross area

Net Section Fracture Requirement

- **Brace Net Area, §F2.5b.(c)**

If using reinforcement :

- Size reinforcement so that $UA_n > A_g$.
- Reinforcement should have yield stress at least equal to yield stress of brace.
- Weld to develop reinforcement *expected* strength on both sides of reduced section.

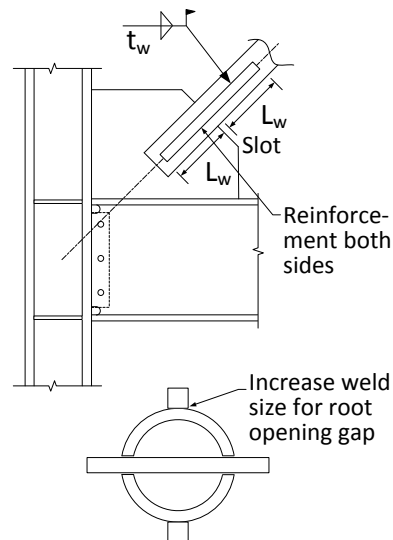

Demand Critical Welds

• Demand Critical Welds

§F2.6a

- Groove welds at column splices.
- Welds at column-to-base plate connections (unless plastic hinging near base plate is prevented and no net uplift).
- Welds at beam-to-column connection if using §F2.6b(c) prescriptive moment connection.

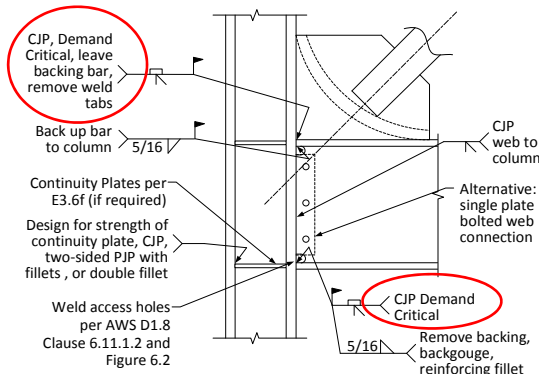

Protected Zone

• Protected Zone Locations

§F2.5c

- Center 1/4 of brace length.
- Within d of the braced connection.
- Connection region.
- **Limitations §D1.3 and §I2.1**
- No tack welds, holes, erection aids, arc gouging, thermal cutting, headed shear studs.
- No welded, bolted, screwed, or power-actuated fastener attachments.

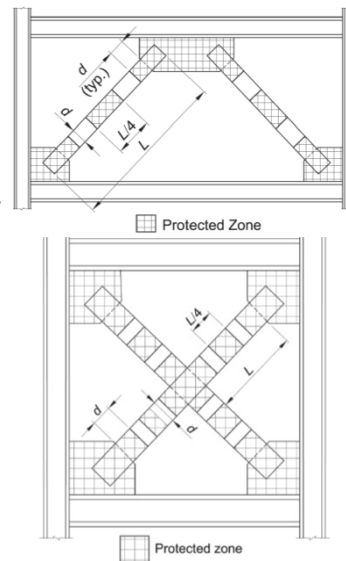

Figures C-F2.14 and C-F2.15 in AISC 341

SCBF - Example

- Do the Following:

1. Calculate the gusset plate required tension and compression strength.
2. Design the gusset plate thickness and fold line dimension.
3. Check the brace net section and design reinforcement.

73

SCBF - Example

1a. Calculate brace connection required tension strength

HSS 6.875x0.500 A500 Gr. B

$A_g = 9.36 \text{ in}^2, F_y = 42 \text{ ksi}, R_y = 1.4$ (Table A3.1)

$$P_{u-tens} = R_y F_y A_g$$

$$P_{u-tens} = 1.4(42 \text{ ksi})(9.36 \text{ in}^2)$$

$P_{u-tens} = 550 \text{ kips}$

74

SCBF - Example

1b. Calculate brace connection required compression strength - use AISC 360 Ch. E with $F_y = R_y F_y$

$$L_b = 144 \text{ in.}, K = 1.0, r = 2.27 \text{ in.} \quad \frac{KL_b}{r} = 63.4$$

$$\left[\frac{KL_b}{r} = 63.4 \right] \leq \left[4.71 \sqrt{\frac{E}{R_y F_y}} = 4.71 \sqrt{\frac{29,000 \text{ ksi}}{1.4(42 \text{ ksi})}} = 105 \right]$$

So use Eq. E3-2 in AISC 360

$$F_e = \frac{\pi^2 E}{\left(\frac{KL_b}{r} \right)^2} = \frac{\pi^2 (29,000 \text{ ksi})}{63.4^2} = 71.2 \text{ ksi}$$

SCBF - Example

1b. Calculate brace connection required compression strength - use AISC 360 Ch. E with $F_y = R_y F_y$

$$F_{cre} = \left[0.658 \frac{R_y F_y}{F_e} \right] R_y F_y = \left[0.658 \frac{(1.4)(42 \text{ ksi})}{(71.2 \text{ ksi})} \right] (1.4)(50 \text{ ksi})$$

$$F_{cre} = 41.6 \text{ ksi}$$

$$P_{u-comp} = \min \left\{ \frac{F_{cre} A_g}{0.877}, R_y F_y A_g \right\}$$

$$P_{u-comp} = 444 \text{ kips}$$

$$P_{u-comp} = \min \left\{ \frac{(41.6 \text{ ksi})(9.36)}{0.877}, 550 \text{ kips} \right\} = 444 \text{ kips}$$

SCBF - Example

2a. Tension Yield on Gusset Whitmore Section

Gusset plate width at end of brace is given as $w_{pa} = 28$ in.

Calculate Whitmore width: w_{pW}

$$w_{pW} = 6.875 \text{ in.} + 2(27 \text{ in.}) \tan(30^\circ)$$

$$w_{pW} = 38.1 \text{ in.}$$

Plate width to use:

$$w_p = \min\{w_{pa}, w_{pW}\} = 28.0 \text{ in.}$$

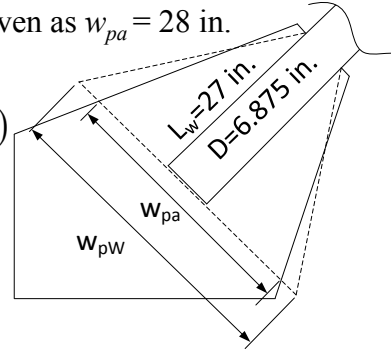

Try 5/8 in. gusset plate

$$\phi R_n = 0.9 F_y t_p w_p = 0.9(50 \text{ ksi})(5/8 \text{ in.})(28.0 \text{ in.}) = 788 \text{ kips}$$

$$\boxed{[\phi R_n = 788 \text{ kips}] \geq [P_{u-tens} = 550 \text{ kips}] \quad \text{OK}}$$

SCBF - Example

2b. Block Shear on Gusset Trying a 5/8 in. gusset

$$A_{nt} = D t_p = (6.875 \text{ in.})(5/8 \text{ in.}) = 4.30 \text{ in}^2$$

$$A_{gv} = 2L_w t_p = 2(27 \text{ in.})(5/8 \text{ in.}) = 33.8 \text{ in}^2$$

$$A_{nv} = A_{gv}$$

Because $A_{nv} = A_{gv}$, shear yield controls

$$\phi R_n = 0.75(0.6 F_{yp} A_{gv} + U_{bs} F_{up} A_{nt})$$

$$\phi R_n = 0.75[0.6(50 \text{ ksi})(33.8 \text{ in}^2) + 1.0(65 \text{ ksi})(4.30 \text{ in}^2)]$$

$$\boxed{[\phi R_n = 970 \text{ kips}] \geq [P_{u-tens} = 550 \text{ kips}] \quad \text{OK}}$$

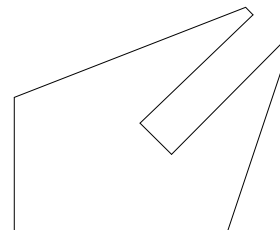

SCBF - Example

2c. Gusset Plate Buckling

Trying a 5/8 in. gusset

$$r_p = \frac{t_p}{\sqrt{12}} = \frac{5/8 \text{ in.}}{\sqrt{12}} = 0.18 \text{ in.}$$

$$\left[\frac{KL_b}{r_p} = \frac{(0.65)(17)}{(0.18)} = 61 \right] \leq 4.71 \sqrt{\frac{E}{F_y}}$$

$$F_e = \frac{\pi^2 E}{\left(\frac{KL_b}{r} \right)^2} = 76.3 \text{ ksi}$$

$$F_{cr} = \left[0.658 \frac{F_y}{F_e} \right] F_y = 38.0 \text{ ksi}$$

$$\phi P_n = 0.9 F_{cr} w_{pa} t_p = 0.9 (38.0 \text{ ksi}) (28 \text{ in.}) (5/8 \text{ in.})$$

$$\left[\phi R_n = 599 \text{ kips} \right] \geq \left[P_{u-comp} = 444 \text{ kips} \right] \quad \text{OK}$$

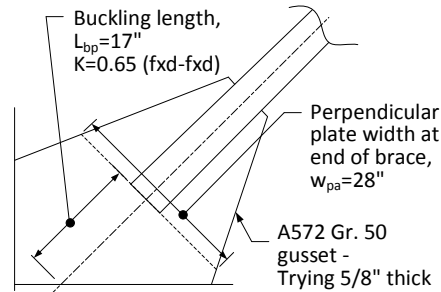

SCBF - Example

3a. Brace Effective Net Section without Reinforcement

HSS 6.875x0.500, $t_{des}=0.465$ in.

Trying a 5/8 in. gusset

$$A_{n-orig} = A_g - 2(t_p + 1/8 \text{ in.})t_{des}$$

$$A_{n-orig} = 9.36 \text{ in}^2 - 2(5/8 \text{ in.} + 1/8 \text{ in.})0.465 \text{ in.}$$

$$A_{n-orig} = 8.66 \text{ in}^2$$

$$U = 1.0 \text{ because } L > 1.3D \quad 28.0 \text{ in.} > (1.3)(6.875 \text{ in.})$$

$$A_{e-orig} = 1.0 A_{n-orig} = 8.66 \text{ in}^2 < A_g = 9.36 \text{ in}^2$$

→ Need reinforcement

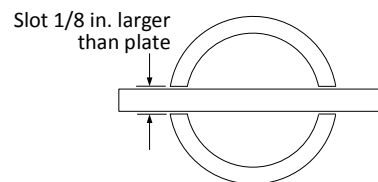

AISC 360 Table D3.1
 Case 5

SCBF - Example

3b. Brace Effective Net Section with Reinforcement

Try 1 in. x 1 in. reinforcement, $t_r = 1.0$ in.
 Can't use $U = 1.0$ now. Calculate U :

$$\bar{x}_{ring} \cong \frac{D}{\pi} = \frac{6.875 \text{ in.}}{\pi} = 2.19 \text{ in.}$$

$$\bar{x}_{reinf} = \frac{D}{2} + \frac{t_r}{2} = 3.94 \text{ in.} \quad \begin{array}{l} \text{AISC 360} \\ \text{Table D3.1} \\ \text{Case 2} \end{array}$$

$$\bar{x} = \frac{\bar{x}_{ring} A_{ring} + \bar{x}_{reinf} A_{reinf}}{A_{ring} + A_{reinf}} = 2.50 \text{ in.}$$

$$U = 1 - \frac{\bar{x}}{L_w} = 1 - \frac{2.50 \text{ in.}}{27.0 \text{ in.}} = 0.91$$

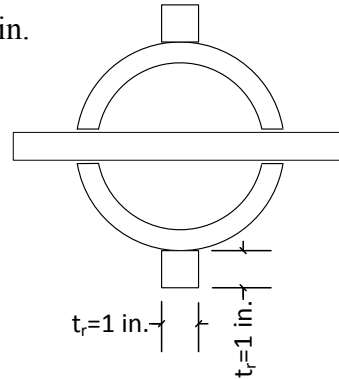

HSS6.875x0.500
 $D = 6.875$ in.

SCBF - Example

3b. Brace Effective Net Section with Reinforcement

Try 1 in. x 1 in. reinforcement, $t_r = 1.0$ in.

$$A_e = U (A_{n-orig} + 2t_r^2)$$

$$A_e = 0.91 (8.66 \text{ in}^2 + 2(1 \text{ in.})^2) = 9.68 \text{ in}^2$$

$$[A_e = 9.68 \text{ in}^2] \geq [A_g = 9.36 \text{ in}^2] \quad \text{OK}$$

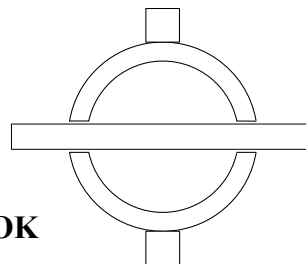

SCBF - Example

3c. Length of Reinforcement

Expected strength of the reinforcement

$$R_{ey} = t_r^2 R_{yr} F_{yr} = (1.0 \text{ in}^2)(1.1)(50 \text{ ksi}) = 55.0 \text{ kips}$$

Try 8 in. long 3/16 in. welds

$$\phi R_n = 2L_{wr} \left(\frac{t_{wr}}{16} \right) 1.392$$

$$\phi R_n = 2(8 \text{ in.})(3 \text{ sixteenths}) 1.392$$

$$\phi R_n = 66.8 \text{ kips}$$

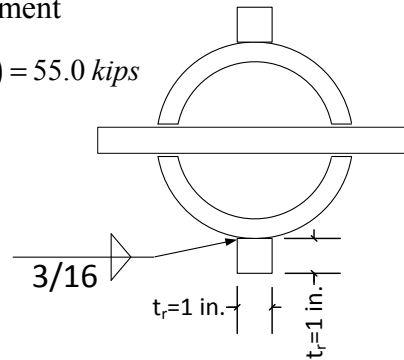

$$[\phi R_n = 66.8 \text{ kips}] \geq [R_{ey} = 55.0 \text{ kips}] \quad \text{OK}$$

SCBF - Example

Fold Line and Final Detail

Fold Line:

$$2t = 2(5/8 \text{ in.})$$

$$2t = 1.25 \text{ in.}$$

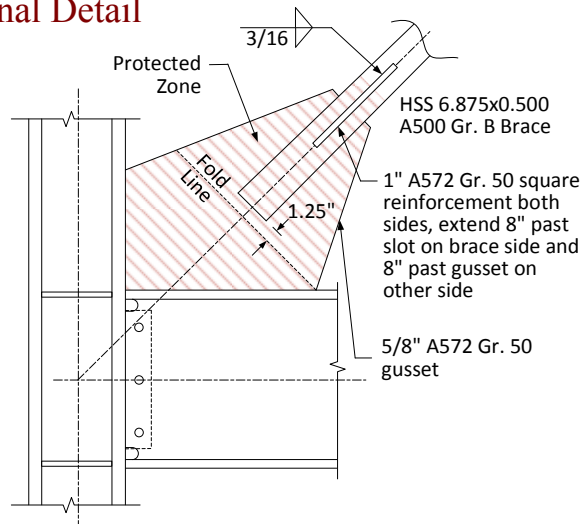

End of Session 7
Thank You for
Attending

Next Up

Next Session

- December 5, 2017 Bracing Connections

TOPICS

- Light Bracing Connections
- Heavy Bracing and Truss Connections
- Poor Designs and More

Individual Webinar Registrants

CEU/PDH Certificates

Within 2 business days...

- You will receive an email on how to report attendance from: registration@aisc.org.
- Be on the lookout: Check your spam filter! Check your junk folder!
- Completely fill out online form. Don't forget to check the boxes next to each attendee's name!



Individual Webinar Registrants

CEU/PDH Certificates

Within 2 business days...

- New reporting site (URL will be provided in the forthcoming email).
- Username: Same as AISC website username.
- Password: Same as AISC website password.



8-Session Registrants

CEU/PDH Certificates

One certificate will be issued at the conclusion of
all 8 sessions.



8-Session Registrants

Access to the quiz: Information for accessing the quiz will be emailed to you by Thursday. It will contain a link to access the quiz. EMAIL COMES FROM NIGHTSCHOOL@AISC.ORG

Quiz and Attendance records: Posted Wednesday mornings.
www.aisc.org/nightschool - click on Current Course Details.

Reasons for quiz:

- EEU – must take all quizzes and final to receive EEU
- CEUs/PDHS – If you watch a recorded session you must take quiz for CEUs/PDHS.
- REINFORCEMENT – Reinforce what you learned tonight. Get more out of the course.

NOTE: If you attend the live presentation, you do not have to take the quizzes to receive CEUs/PDHS.



8-Session Registrants

Access to the recording: Information for accessing the recording will be emailed to you by this Thursday. The recording will be available for three weeks. For 8-session registrants only. EMAIL COMES FROM NIGHTSCHOOL@AISC.ORG.

CEUs/PDHS – If you watch a recorded session you must take AND PASS the quiz for CEUs/PDHS.



Night School Resources for 8-session package Registrants

Find all your handouts, quizzes and quiz scores, recording access, and attendance information all in one place!



Night School Resources for 8-session package Registrants

Go to www.aisc.org and sign in.

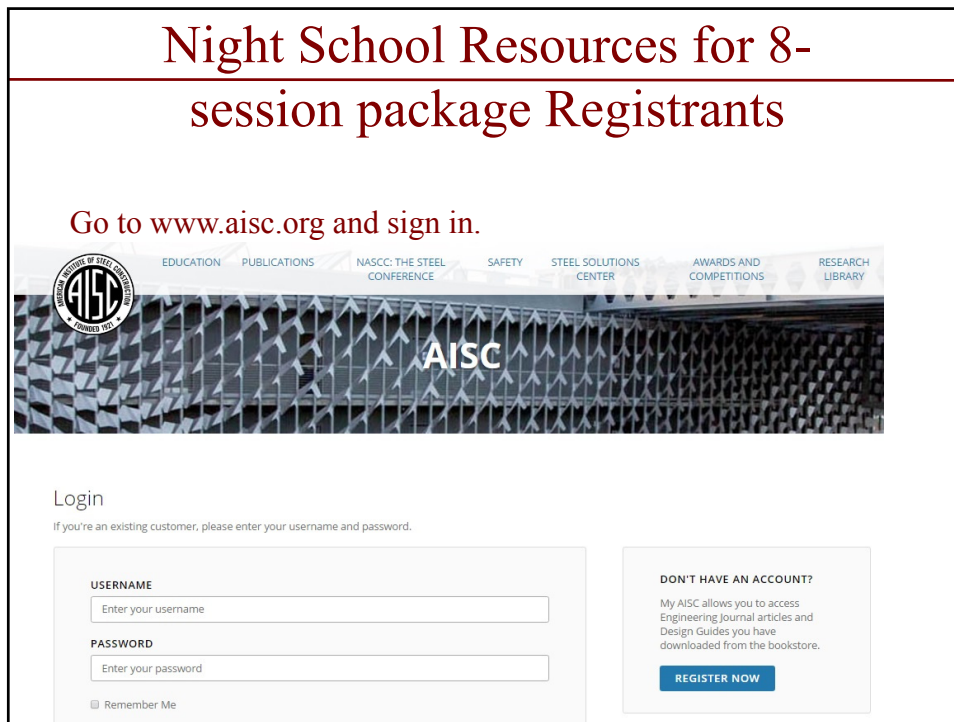

EDUCATION PUBLICATIONS NASCC: THE STEEL CONFERENCE SAFETY STEEL SOLUTIONS CENTER AWARDS AND COMPETITIONS RESEARCH LIBRARY

LOGIN

If you're an existing customer, please enter your username and password.

USERNAME
Enter your username

PASSWORD
Enter your password

Remember Me

DON'T HAVE AN ACCOUNT?

My AISC allows you to access Engineering Journal articles and Design Guides you have downloaded from the bookstore.

[REGISTER NOW](#)

Night School Resources for 8-session package Registrants

Go to www.aisc.org and sign in.

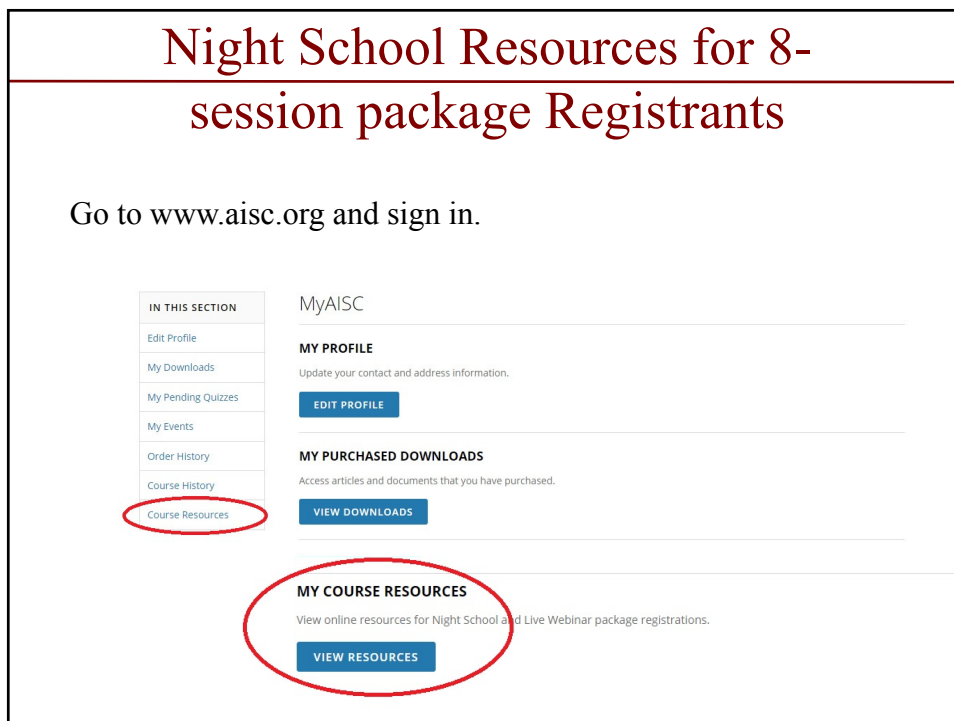

IN THIS SECTION

- Edit Profile
- My Downloads
- My Pending Quizzes
- My Events
- Order History
- Course History
- Course Resources

MyAISC

MY PROFILE

Update your contact and address information.

[EDIT PROFILE](#)

MY PURCHASED DOWNLOADS

Access articles and documents that you have purchased.

[VIEW DOWNLOADS](#)

MY COURSE RESOURCES

View online resources for Night School and Live Webinar package registrations.

[VIEW RESOURCES](#)



Night School Resources for 8-session package Registrants

Event	Start Date
NS 13 8-Session Package-Night School 13 - Design of Industrial Buildings	1/30/2017 7:00:00 PM
NS 14 8-Session Package-Night School 14 - Fundamentals of Stability	6/5/2017 7:00:00 PM

Night School Resources for 8-session package Registrants

8-SESSION PACKAGE RESOURCES

Event	Date	Handouts	Video	Quiz	Attendance
NS13 - Design Criteria	1/30/2017 7:00:00 PM	Handouts	View Passcode: NS13DSN	Pass Score: 80	Pending
NS13 - Economic Considerations	2/6/2017 7:00:00 PM	Handouts	Available 02/08/2017 5pm EST	Available 02/08/2017 5pm EST	Pending
NS13 - Lateral Load Systems and Details	2/13/2017 7:00:00 PM	Handouts	Available 02/15/2017 5pm EST	Available 02/15/2017 5pm EST	Pending
NS13 - Preliminary Design Procedures	2/27/2017 7:00:00 PM	Handouts	Available 03/01/2017 5pm EST	Available 03/01/2017 5pm EST	Pending
NS13 - Crane Girder Design and Frame Analysis	3/6/2017 7:00:00 PM	Handouts	Available 03/08/2017 5pm EST	Available 03/08/2017 5pm EST	Pending
NS13 - Frame Member and Connection Design	3/13/2017 7:00:00 PM	Handouts	Available 03/15/2017 5pm EST	Available 03/15/2017 5pm EST	Pending
NS13 - Transfer Crane Girder & Longitudinal Bldg Bracing Dsn	3/27/2017 7:00:00 PM	Handouts	Available 03/29/2017 5pm EST	Available 03/29/2017 5pm EST	Pending
NS13 - Building Envelope and Bracing Design	4/3/2017 7:00:00 PM	Handouts	Available 04/05/2017 5pm EST	Available 04/05/2017 5pm EST	Pending
NS13 - Final Exam	4/10/2017 7:00:00 PM			Available 04/12/2017 5pm EST	



Night School Resources for 8- session package Registrants

- Weekly “quiz and recording” email.
- Weekly updates of the master Quiz and Attendance record found at www.aisc.org/nightschool. Scroll down to Quiz and Attendance records.
 - Updated on Wednesday mornings.



Night School Resources for 8- session package Registrants

- Webinar connection information:
 - Found in your registration confirmation/receipt.
 - Reminder email sent out Tuesday mornings.
- Link to handouts also found here.



There's always a solution in steel.

Thank You

Please give us your feedback!
Survey at conclusion of webinar.

