



Thank you for joining our live webinar today.  
We will begin shortly. Please standby.

Thank you.



Need Help?  
Call ReadyTalk Support: 800.843.9166

Today's audio will be broadcast through the internet.

Alternatively, to hear the audio through the phone, dial 866-519-2796. Passcode: 171172

---





Today's live webinar will begin shortly.  
Please standby.

**As a reminder, all lines have been muted. Please type any questions or comments through the Chat feature on the left portion of your screen.**

Today's audio will be broadcast through the internet.  
Alternatively, to hear the audio through the phone, dial 866-519-2796. Passcode: 171172

---





*AISC is a Registered Provider with The American Institute of Architects Continuing Education Systems (AIA/CES). Credit(s) earned on completion of this program will be reported to AIA/CES for AIA members. Certificates of Completion for both AIA members and non-AIA members are available upon request.*

*This program is registered with AIA/CES for continuing professional education. As such, it does not include content that may be deemed or construed to be an approval or endorsement by the AIA of any material of construction or any method or manner of handling, using, distributing, or dealing in any material or product.*

*Questions related to specific materials, methods, and services will be addressed at the conclusion of this presentation.*

---





### Copyright Materials

This presentation is protected by US and International Copyright laws. Reproduction, distribution, display and use of the presentation without written permission of AISC is prohibited.

© The American Institute of Steel Construction 2018



### Course Description

#### Session 4: Seismic Design of Buildings March 12, 2018

This session presents the formal relationship of codes in the US and explains the basic concepts employed in code- seismic design, such as seismic design category, maximum considered earthquake, importance factor, etc. General analysis, design requirements and detailed systems (designed using the AISC Seismic Provisions) and non-detailed systems (designed using only the AISC Specification) will be discussed. The session will also review treatment of wind-vs.-seismic comparison issues, diaphragms and deformation compatibility.



### Learning Objectives

- Describe the relationship of local, model and steel codes employed in seismic design.
- Describe the the steps per ASCE 7 in which earthquake demand is determined.
- Describe the response modification factor, R, and how and why it differs depending on the seismic force resisting system.
- List the irregularities, both horizontal and vertical, that must be considered in the seismic design of a building.



There's always a solution in steel.

## Seismic Design in Steel: Concepts and Examples

Session 4: Seismic Design of Buildings  
March 12, 2018



Rafael Sabelli, SE





## Course objectives

- Understand the principles of seismic design of steel structures.
- Understand the application of those principles to two common systems:
  - Special Moment Frames
  - Buckling-Restrained Braced Frames.
- Understand the application of design requirements for those systems.



9

## Resources

- AISC *Seismic Design Manual*
- *Ductile Design of Steel Structures*, Bruneau, Uang, and Sabelli, McGraw Hill.
- *Earthquakes and Seismic Design, Facts for Steel Buildings #3*. Ronald O. Hamburger, AISC.
- Other publications suggested in each session

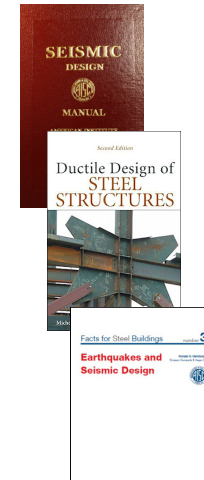

10

## Other resources

- AISC Solutions Center
  - 866.ASK.AISC (866-275-2472)
  - Solutions@AISC.org
- AISC Night School
  - Nightschool@AISC.org



11

## Course outline

### Part I: Concepts

1. Introduction to effective seismic design
2. Seismic design of moment frames
3. Seismic design of braced frames
4. **Seismic design of buildings**



12



### Course outline

**Part II: Application**

- 5.Planning the seismic design
- 6.Building analysis and diaphragm design
- 7.Design of the moment frames
- 8.Design of the braced frames



There's always a solution in steel.

### Session 4: Seismic design of buildings

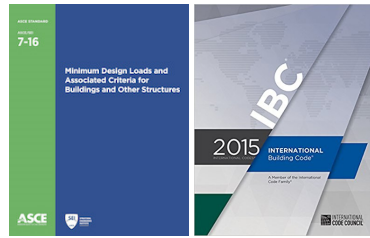

### Session topics

- System of codes
- ASCE 7
- Diaphragms
- Deformation compatibility
- Wind vs. seismic



There's always a solution in steel.

### System of codes



### System of codes

- Local or state code
  - Adopts (or copies from)
- Model code (International Building Code = IBC)
  - Addresses
    - Occupancies
    - Plan review
    - Inspection
  - Adopts
- ASCE 7

17

### System of codes

- ASCE 7
  - Addresses
    - Loads
    - Analysis
    - System limits
  - ASCE 7 & IBC Adopt
    - AISC 360
      - Specification
    - AISC 341
      - Seismic Provisions
    - ACI 318

18

### System of codes

- AISC 360
  - Addresses
    - Materials
    - Strength of members and connections
    - Analysis
  - Adopts
    - AWS D1.1
      - Structural welding code
    - (AISC 341)

19

### System of codes

- AISC 341
  - Addresses
    - Proportioning
    - Detailing
    - Materials
    - Analysis
  - Adopts
    - AISC 358
      - Prequalified moment connections
    - AWS D1.8
      - Seismic welding supplement

20



There's always a solution in steel.

# ASCE 7



# ASCE 7

- Underlying concepts
- Fundamental requirements
- Methodology
  - Seismic Design Category
  - Seismic systems
  - Irregularities
  - Seismic base shear
  - Analysis methodology
  - Diaphragms

---



22

There's always a solution in steel.

# ASCE 7: Underlying concepts



# Underlying concepts

- Earthquake demand
  - Risk-targeted Maximum Considered Earthquake ( $MCE_r$ )
    - Return period 500-2500 years
    - Given the  $MCE_r$ , there should be no more than 10% chance of collapse.
    - $MCE_r$  selected such that typical (new) building designed per ASCE 7 for  $MCE_r$  accelerations no more than 1% chance of (earthquake induced) collapse in 50 year period

---



24



### Underlying concepts

- Earthquake demand
  - Risk-targeted Maximum Considered Earthquake ( $MCE_r$ )
    - Adjusted for local soil conditions
    - Multiplied by  $2/3$  and divided by  $R/I_e$  for design



### Underlying concepts

- Earthquake demand
  - Multiplied by  $2/3$ 
    - $2/3$  factor should be understood as multiplying  $R$  by 1.5
  - Response reduction factor  $R$ 
    - Represents ductility ( $R_\mu$ )
    - Also overstrength (" $R_o$ ")
  - $I_e > 1$  represents lower permitted ductility demand for higher Risk Category structures



### Underlying concepts

- Risk Category
  - Occupancy
    - Number of people at risk
    - Importance for post-earthquake response and recovery
  - Danger to the public
    - Number of people at risk
  - Importance factors
  - Drift limits



### Risk Categories



Risk Category I: Shed



Risk Category II: House

#### Examples



Risk Category III: School (assembly)



Risk Category IV: Hospital



Risk Category IV: Hazardous facility



## Underlying concepts

Table 1.5-1 Risk Category of Buildings and Other Structures for Flood, Wind, Snow, Earthquake, and Ice Loads

Use or Occupancy of Buildings and Structures	Risk Category
Buildings and other structures that represent a low risk to human life in the event of failure	I
All buildings and other structures except those listed in Risk Categories I, III, and IV	II
Buildings and other structures, the failure of which could pose a substantial risk to human life.	III
Buildings and other structures, not included in Risk Category IV, with potential to cause a substantial economic impact and/or mass disruption of day-to-day civilian life in the event of failure.	III
Buildings and other structures not included in Risk Category IV (including, but not limited to, facilities that manufacture, process, handle, store, use, or dispose of such substances as hazardous fuels, hazardous chemicals, hazardous waste, or explosives) containing toxic or explosive substances where their quantity exceeds a threshold quantity established by the authority having jurisdiction and is sufficient to pose a threat to the public if released.	III
Buildings and other structures designated as essential facilities.	IV
Buildings and other structures, the failure of which could pose a substantial hazard to the community	IV
Buildings and other structures (including, but not limited to, facilities that manufacture, process, handle, store, use, or dispose of such substances as hazardous fuels, hazardous chemicals, or hazardous waste) containing sufficient quantities of highly toxic substances where the quantity exceeds a threshold quantity established by the authority having jurisdiction to be dangerous to the public if released and is sufficient to pose a threat to the public if released.	IV
Buildings and other structures required to maintain the functionality of other Risk Category IV structures.	IV
Buildings and other structures containing toxic, highly toxic, or explosive substances shall be eligible for classification to a lower Risk Category if it can be demonstrated to the satisfaction of the authority having jurisdiction by a hazard assessment as described in Section 1.5.2 that a release of the substances is commensurate with the risk associated with that Risk Category.	IV

Risk Category from Table 1.5-1	Seismic Importance Factor, $I_e$
I	0.020h
II	0.020h
III	0.015h
IV	0.010h

Table 12.12-1 Allowable Story Drift,  $\Delta_s^{all}$



## Underlying concepts

- Response spectrum
  - Generalized spectrum
  - Constructed from spectral acceleration at
    - 0.2 sec. period
    - 1.0 sec. period
    - “ $T_L$ ”
  - Values mapped by USGS
    - Based on stiff soil/rock
    - Adjusted for other conditions

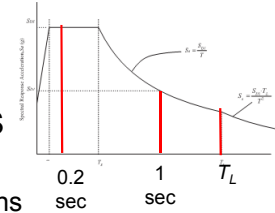

## Underlying concepts

- USGS maps
  - Printed maps in ASCE 7
  - Separate maps for
    - Peak Ground Acceleration (PGA)
    - 0.2 sec.
    - 1.0 sec.
    - $T_L$

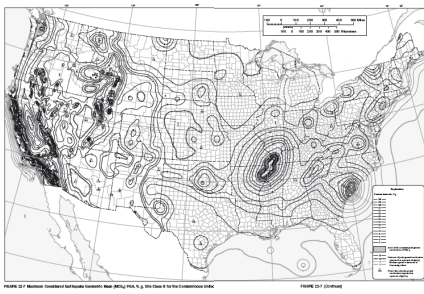

## Underlying concepts

- USGS maps
  - Web application
    - Same data
    - Read using latitude and longitude
    - Processed for soil type, etc.

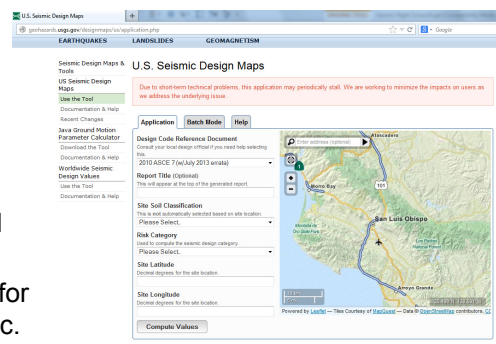

<https://earthquake.usgs.gov/designmaps/us/application.php>



### Underlying concepts

- Response spectrum

MCE<sub>r</sub> Response Spectrum

Modified for soil type and Multiplied by 2/3

Design Response Spectrum

ASCE 7 §11.4.4

33

### Underlying concepts

- Response spectrum
  - MCE<sub>r</sub> Response Spectrum
    - Performance tied to this level
      - ≤10% chance of collapse
  - “Design Response Spectrum”
    - 2/3 MCE<sub>r</sub> Response Spectrum
    - No performance defined
    - No design for “Design Response Spectrum”
  - Reduced Response Spectrum
    - 1/R \* Design Response Spectrum
    - Design at this level

ASCE 7 §11.4.4

34

There's always a solution in steel.

## ASCE 7: Fundamental Requirements

## Fundamental Requirements

- Strength
  - The seismic-load-resisting system must have sufficient strength to limit ductility demands
    - Reduced spectrum used  $\frac{2/3 MCE_r}{R/I_e}$ 
      - 2/3 factor is the same as increasing R factor 50%
        - R originally targeted life safety (475-year return period)
        - 1.5R targets collapse prevention (2475-year)
    - System-specific R factor implies level of ductility

36



### Fundamental Requirements

R factor	Systems
8	Special Moment Frames Eccentrically Braced Frames Buckling-Restrained braced Frames
7	Steel Plate Shear Walls Special Truss Moment Frame
6	Special Concentrically Braced Frames
4.5	Intermediate Moment Frames
3.5	Ordinary Moment Frames
3.25	Ordinary Concentrically Braced Frames
3	Non-detailed braced frames and moment frames
2.5	Special Cantilevered Columns
1.25	Ordinary Cantilevered Columns



ASCE 7 Table 12.2-1

### ASCE 7 Base Shear

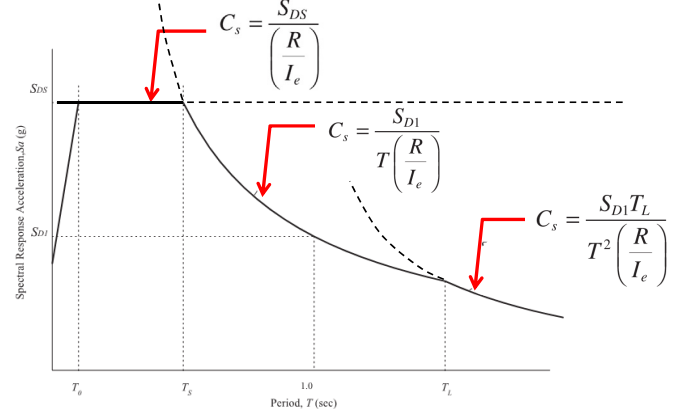

ASCE 7 §12.8.1

### Fundamental Requirements

- Strength
  - Determine structural period
    - Using approximate methods
      - Approximate period formulae in ASCE 7 §12.8.2.1
      - Based on measured response
        - Includes effects of cladding, partitions, etc.

System	C <sub>t</sub>	x
Moment Frames	0.028	0.8
EBF & BRBF	0.03	0.75
Other	0.02	0.75

$$T_a = C_t h_n^x$$



### Fundamental Requirements

- Strength
  - Determine structural period
    - Using building model
      - Period from model
      - Over-estimate of period results in lower required strength
      - Code imposes maximum period to be used for strength k
        - $T \leq C_u T_a$

Design Spectral Response Acceleration Parameter at 1 s, S <sub>D1</sub>	Coefficient C <sub>u</sub>
≥ 0.4	1.4
0.3	1.4
0.2	1.5
0.15	1.6
≤ 0.1	1.7



ASCE 7 §12.8.2



## Fundamental Requirements

- Stiffness
  - The seismic-load-resisting system must have sufficient stiffness to control drift
    - Reduce damage
    - Prevent instability  $\frac{2/3 MCE_r}{R/I_e}$
    - Reduced spectrum used
  - Amplified by system specific factor  $C_d$
  - Corrected by  $I_e$   $\frac{2/3 MCE_r C_d}{R}$



## Fundamental Requirements

- Stiffness
  - $C_d/R$ 
    - Theoretically  $C_d/R = 1.0$ 
      - “Equal displacement rule”
    - $C_d/R < 1.0$ 
      - Reflects traditional design practice
      - Corresponds to drift limits in code
      - Variation in not well supported



## Fundamental Requirements

$C_d/R$	Systems
0.5	Eccentrically Braced Frames
0.625	Buckling-Restrained braced Frames
0.688	Special Moment Frames
0.786	Special Truss Moment Frame
0.833	Special Concentrically Braced Frames
0.857	Steel Plate Shear Walls Ordinary Moment Frames
0.889	Intermediate Moment Frames
1	Ordinary Concentrically Braced Frames Non-detailed braced frames and moment frames Special Cantilevered Columns Ordinary Cantilevered Columns



ASCE 7 Table 12.2-1

## Fundamental Requirements

Mapped $MCE_r$ values	Adjusted for soil type	Multiplied by 2/3	Reduced for strength design	Amplified for drift check
Hazard level		SDC determined at this level	Strength checked at this level	Drift checked at this level
$S_S$ (0.2 sec)	$S_{MS} = F_a S_S$	$S_{DS} = 2/3 S_{MS}$	$V = W^* S_{DS} / [R/I_e]$	$\delta = W^* S_{DS}^* (C_d/R) / K$
$S_{M1}$ (1.0 sec)	$S_{M1} = F_v S_S$	$S_{D1} = 2/3 S_{M1}$	$V = W^* S_{D1} / (T^* [R/I_e])$	$\delta = W^* S_{D1}^* (C_d/R) / K T$



### Fundamental Requirements

- Proportioning
  - Critical elements required to be designed for amplified load
    - $E_m = \Omega_o E$ 
      - Represents system overstrength
      - $2 \leq \Omega_o \leq 3$
  - Collectors
  - Elements supporting discontinuous frames
  - Other triggers for this in AISC 341

$$\Omega_o \frac{2/3 MCE_r}{R/I_e}$$



### Protected element

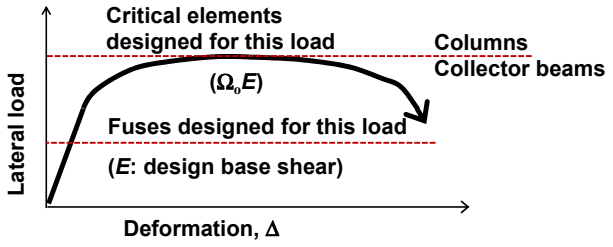

### Fundamental Requirements

- Integrity
  - The seismic-load-resisting system must have sufficient integrity to prevent separation elements and components
    - Tie or anchorage forces are required for all components
    - Deformability is required to accommodate seismic displacements



### Fundamental Requirements

- Stability
- The seismic-load-resisting system must have sufficient strength and stiffness to limit second order effects
  - A second order check is performed
  - The permissible level can be increased for systems with extra capacity (overstrength)

$$\theta = \frac{P_x \Delta I_e}{V_x h_{sx} C_d} = \frac{P_x \Delta_{elastic}}{V_x h_{sx}} = \frac{P_x / h_{sx}}{K_x} \quad \theta_{max} = \frac{0.5}{\beta C_d} \leq 0.25$$

Where  $\beta$  is the ratio of shear demand to shear capacity



## Fundamental Requirements

- Redundancy
  - Factor  $\rho = 1.0$ 
    - Systems with multiple elements well distributed
  - Factor  $\rho = 1.3$ 
    - Systems with few elements, poor distribution, or with high torsion
  - Tests
    - Prescriptive check: 2 or more perimeter frames
    - Analysis: remove one member
      - Check torsion and strength

---





ASCE 7 §12.3.4

49

## Fundamental Requirements

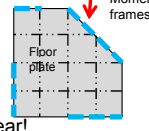
- Direction of loading
  - Seismic ground motions are 3-dimensional
  - Strong accelerations can happen at any plan angle
    - Worst case for skewed frames determined
      - Application of load aligned with frame
      - 100%+30% of results from principal axes
      - SRSS of results from principal axes
      - Orthogonal combination creates 141% of base shear!
  - Intersecting frames have columns affected by each direction of loading
    - Requirements vary by system

---



ASCE 7 §12.3.4

50

There's always a solution in steel.

## ASCE 7: Seismic Design Category



## Seismic Design Category (SDC)

- ASCE 7 §11.6
- Based on
  - Risk category
  - Site seismicity
    - Including soil effects
    - Check for
      - 0.2 sec response
      - 1.0 sec response
      - $S_1 \geq 0.75$ 
        - SDC E: RC I, II, III
        - SDC F: RC IV

Value of $S_{DS}$	Risk Category	
	I or II or III	IV
$S_{DS} < 0.167$	A	A
$0.167 \leq S_{DS} < 0.33$	B	C
$0.33 \leq S_{DS} < 0.50$	C	D
$0.50 \leq S_{DS}$	D	D

Value of $S_{D1}$	Risk Category	
	I or II or III	IV
$S_{D1} < 0.067$	A	A
$0.067 \leq S_{D1} < 0.133$	B	C
$0.133 \leq S_{D1} < 0.20$	C	D
$0.20 \leq S_{D1}$	D	D

---



ASCE 7 §11.6

52



## Seismic Design Category (SDC)

- Affects
  - Permissible systems
  - System height limits
  - Design requirements
  - Analysis requirements
  - Irregularity penalties



53

## Seismic Design Category

- Seismic Design Categories (SDC)
  - SDC A
    - No seismic design
    - Basic system integrity requirements of ASCE 7 (Section 1.4) deemed sufficient
  - SDC B
    - Limits on cantilever-column systems
    - Restrictions on certain non-steel systems



54

## Seismic Design Category

- Seismic Design Categories (SDC)
  - SDC C
    - All SDC B requirements
    - More restrictions on non-steel systems
    - Amplified collector forces
    - Geotechnical investigation required
    - Consideration of bi-directional ground motion
    - Special foundation-design requirements



55

## Seismic Design Category

- Seismic Design Categories (SDC)
  - SDC D
    - All SDC C requirements
    - Additional geotechnical investigation items required
    - Restriction on system types
    - Lower system height limits
    - Certain irregularities not permitted
    - Certain irregularity penalties
    - Consideration of structural redundancy



56



## Seismic Design Category

- Seismic Design Categories (SDC)
  - SDC D
    - Vertical seismic forces on cantilevers
    - Special design of columns shared by intersecting frames (corner columns)
    - Limitations on analysis type
    - Consideration of deformation compatibility
    - Additional foundation-design requirements

57

## Seismic Design Category

- Seismic Design Categories (SDC)
  - SDC E and F
    - All SDC D requirements
    - Not permitted on active fault rupture location
    - Certain irregularities not permitted

58

There's always a solution in steel.

## ASCE 7: Seismic systems



ASCE 7 Table 12.2-1 Seismic Force Resisting System	Resp. Mod. Coeff., $R^a$	Over-strength Factor, $\Omega_o$	Deflection Amp. Factor, $C_d^b$	Structural System Limitations Including Structural Height, $h_n$ , Limits in ft <sup>c</sup>				
				Seismic Design Category				
				B	C	D <sup>d</sup>	E <sup>d</sup>	F <sup>e</sup>
<b>STEEL SYSTEMS</b>				Up to 240' for regular buildings				
Steel eccentrically braced frames (EBF)	8	2	4	NL	NL	160	160	100
Steel special concentrically braced frames (SCBF)	6	2	5	NL	NL	160	160	100
Steel ordinary concentrically braced frames (OCBF)	3 <sup>1/4</sup>	2	3 <sup>1/4</sup>	NL	NL	35 <sup>g</sup>	35 <sup>g</sup>	NP <sup>h</sup>
Steel buckling-restrained braced frames (BRBF)	8	2 <sup>1/2</sup>	5	NL	NL	160	160	100
Steel special plate shear walls (SPSW)	7	2	6	NL	NL	160	160	100
Steel special moment frames (SMF)	8	3	5 <sup>1/2</sup>	NL	NL	NL	NL	NL
Steel special truss moment frames (STMF)	7	3	5 <sup>1/2</sup>	NL	NL	160	100	NP
Steel intermediate moment frames (IMF)	4 <sup>1/2</sup>	3	4	NL	NL	35 <sup>h</sup>	NP <sup>h</sup>	NP <sup>h</sup>
Steel ordinary moment frames (OMF)	3 <sup>1/2</sup>	3	3	NL	NL	NP <sup>i</sup>	NP <sup>i</sup>	NP <sup>i</sup>
Steel special cantilever column systems (SCCS)	2 <sup>1/2</sup>	1 <sup>1/4</sup>	2 <sup>1/2</sup>	35	35	35	35	35
Steel ordinary cantilever column systems (OCCS)	1 <sup>1/4</sup>	1 <sup>1/4</sup>	1 <sup>1/4</sup>	35	35	NP <sup>i</sup>	NP <sup>i</sup>	NP <sup>i</sup>
Steel systems not specifically detailed for seismic resistance	3	3	3	NL	NL	NP	NP	NP



### R=3 vs R>3

- R=3
  - AISC 360
    - Design
    - QA/QC
    - Analysis
  - ASCE 7
    - Limits
    - Analysis
    - Overstrength, irregularity, & redundancy
      - By SDC
- R>3 (and cantilever systems)
  - All R=3 requirements
  - AISC 341
    - General requirements
      - Columns
      - Connections
    - System requirements
      - Design/proportioning
      - Detailing
    - QA/QC



61

There's always a solution in steel.

### ASCE 7: Irregularities



### Irregularities

- Horizontal (plan)
  - Torsional
  - Re-entrant corner
  - Diaphragm discontinuity
  - Out-of-plane offset
  - Non-parallel systems
- Vertical (elevation)
  - Soft story
  - Mass
  - Geometric
  - In-plane offset
  - Weak story

Irregularities presented in detail in Session 5



ASCE 7 Table 12.3-1

ASCE 7 Table 12.3-2

63

There's always a solution in steel.

### ASCE 7: Analysis methodology



### Analysis methods

- Equivalent Lateral Force (ELF)
- Modal Response Spectrum Analysis (MRSA)
- Response History Analysis (RHA)



ASCE 7 Table 12.6-1

65

### Analysis methods

- Equivalent Lateral Force (ELF)
  - Base shear applied in pattern similar to inverted triangle
  - Captures story shear
  - Captures overturning
  - Supplemental diaphragm forces capture forces at lower stories

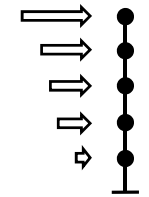

ASCE 7 §12.8

66

### Analysis methods

- Modal Response Spectrum Analysis (MRSA)
  - Base shear scaled to 85% ELF base shear (100% in ASCE 7-16)
  - Assumed benefit to supposedly more accurate analysis
    - Not borne out in reliability comparisons
  - Tends to exhibit far less overturning

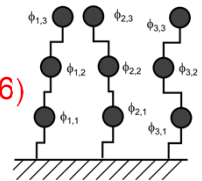

ASCE 7 §12.9

67

### Analysis methods

- Modal Response Spectrum Analysis (MRSA)
  - Modes are combined using SRSS
    - Signs are lost
    - Static consistency is lost
    - Quantities of interest (e.g., drift) must be tracked mode by mode and combined
      - Difference between maxima is not meaningful

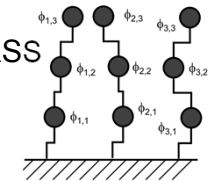

ASCE 7 §12.9

68



## Analysis methods

- Response History Analysis (RHA)
  - Linear analysis
    - Ground motion histories based on  $MCE_r$  hazard
    - Scaled to match response value for range near fundamental period ( $T$  to  $1.5T$ )
    - Adjusted same as other methods
      - Soil factors
      - $2/3$
      - $R/I_e$
      - $C_d/I_e$



ASCE 7 §16

69

## Analysis methods

- Response History Analysis (RHA)
  - Nonlinear analysis
    - Ground motion histories based on  $MCE_r$  hazard
    - Scaled to match response value for range near fundamental period ( $T$  to  $1.5T$ )
    - Adjusted by
      - Soil factors
    - Response
      - Need to establish element nonlinear deformation limits
      - Reduce drift for comparison with code limits



ASCE 7 §16

70

## Analysis methods

- Response History Analysis (RHA)
  - Nonlinear analysis
    - Elements divided
      - "Deformation-controlled"
        - Nonlinear modeling
        - Deformation limits based on
          - » Testing
          - » Other sources (ASCE 41)
      - "Force-controlled"



ASCE 7 §16

71

## Analysis methods

- Response History Analysis (RHA)
  - Nonlinear analysis
    - Elements divided
      - "Force-controlled"
        - Linear modeling
        - Strength per design standard
          - » AISC 360
          - » ACI 318
          - » etc.



ASCE 7 §16

72



### Analysis methods

- Response History Analysis (RHA)
  - Nonlinear analysis
    - Statistics
      - 3-6 ground-motion pairs
        - Use maximum values
      - 7+ ground-motion pairs
        - Use mean values
    - 11 ground-motion pairs required in ASCE 7 16, except
      - » 7 for seismic isolation
      - » 7 for engineered damped systems



ASCE 7 §16

### Analysis Methods

Permitted Analysis Methods  
 Table 12.6-1

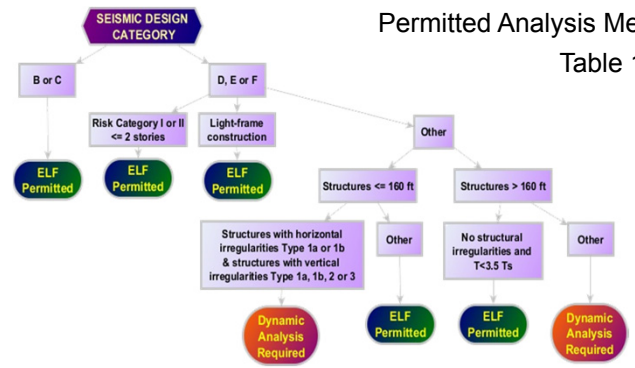

### Analysis methods

- ELF or MRSA or RHA
  - Seismic Design Category B or C
    - No restrictions
  - Seismic Design Category D, E, or F
    - Light Frame
    - Risk Category I or II buildings ≤ 2 stories
    - Buildings ≤ 160ft
      - Without:
        - Horizontal irregularities 1a or 1b (torsional)
        - Vertical irregularities 1a, 1b, 2, or 3 (soft story, weight, vertical geometric)



### Analysis methods

- ELF or MRSA or RHA
  - Seismic Design Category D, E, or F
    - Buildings > 160ft
      - Without any irregularities, and
      - $T \leq 3.5T_s$ 
        - $T_s = S_{D1} / S_{Ds}$

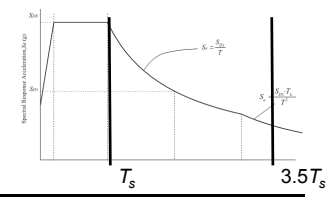

### Analysis methods

- MRSA or RHA (ELF not allowed)
  - Seismic Design Category D, E, or F
    - Buildings  $\leq 160\text{ft}$ 
      - With:
        - Horizontal irregularities 1a or 1b (torsional), or
        - Vertical irregularities 1a, 1b, 2, or 3 (soft story, weight, vertical geometric)
    - Buildings  $> 160\text{ft}$ 
      - With any irregularity, or
      - $T > 3.5T_s$



There's always a solution in steel.

## ASCE 7: Diaphragms

### Roles of diaphragms

- Support gravity
- Deliver forces to frames
- Brace columns for stability
- Transfer forces between frames
- Resist P- $\Delta$  thrust

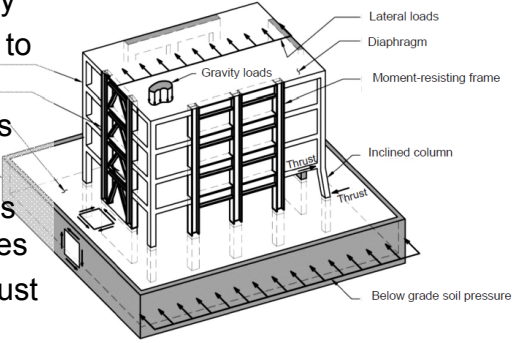

### Diaphragm forces

- Vertical force distribution insufficient

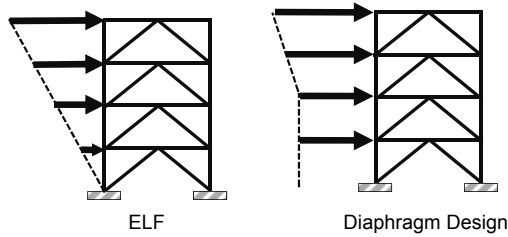

### ELF vertical distribution

Force

Under-estimated

Shear

Overturning

$$C_{vx} = \frac{w_x h_x^k}{\sum_{i=1}^n w_i h_i^k}$$

ASCE 7  
Eq. 12.8-12

81

### Diaphragm force coefficients

Force

Overestimated Shear

Overestimated Overturning

$$F_{pi} \leq 0.4 S_{DS} / W_{px}$$

$$F_{px} = \frac{\sum_{i=x}^n F_i}{\sum_{i=x}^n W_i} W_{px}$$

ASCE 7  
Eq. 12.10-1

$$F_{pi} \geq 0.2 S_{DS} / W_{px}$$

82

### Combining diaphragm and transfer forces

$F_5$   
 $F_4$   
 $F_3$   
 $F_2$

Building design forces

$F_{p5}$   
 $F_{p4}$   
 $F_{p3}$   
 $F_{p2}$

Diaphragm design forces

Applied for transfer forces

$F_5$   
 $F_4$   
 $F_3$   
 $F_2$

$F_5$   
 $F_4$   
 $F_3$   
 $F_2$

Analysis for 2<sup>nd</sup>-floor diaphragm + transfer forces

$F_5$   
 $F_4$   
 $F_3$   
 $F_2$

Analysis for 3<sup>rd</sup>-floor diaphragm + transfer forces

$F_5$   
 $F_4$   
 $F_3$   
 $F_2$

Analysis for 4<sup>th</sup>-floor diaphragm + transfer forces

83

## Collectors

There's always a solution in steel.



### Beam-columns

- Compressive strength
  - $\Omega_o E_h$  (ASCE 7 §12.10.2)
  - Wide-flange with discreet lateral and torsional bracing
    - Major axis flexural buckling
    - Minor-axis flexural buckling
    - Torsional buckling
      - Higher strength than minor-axis FB for same unbraced length

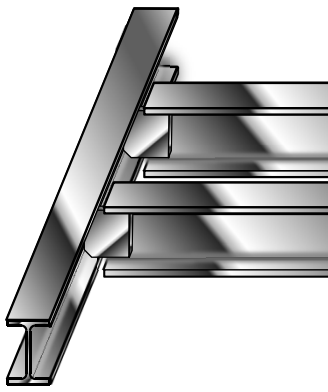



85

### Beam-columns

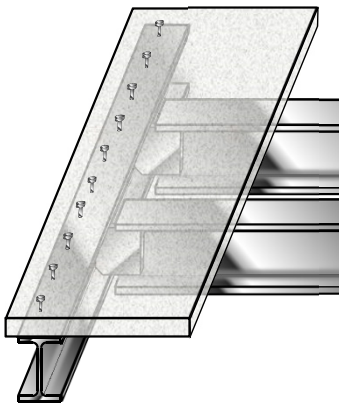
- Compressive strength
  - Wide-flange with continuous lateral bracing
    - Major axis flexural buckling
    - Constrained-axis flexural-torsional buckling
      - Strength between minor-axis FB and torsional buckling



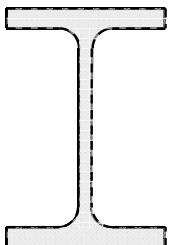

86

### Constrained-axis flexural-torsional buckling

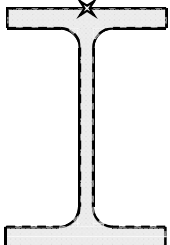

Minor axis flexural buckling  
(no restraint)



Constrained-axis  
Flexural-torsional buckling  
(restraint at top flange)

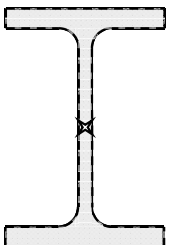



Torsional buckling  
(restraint at centroidal axis)

87

### Beam-columns

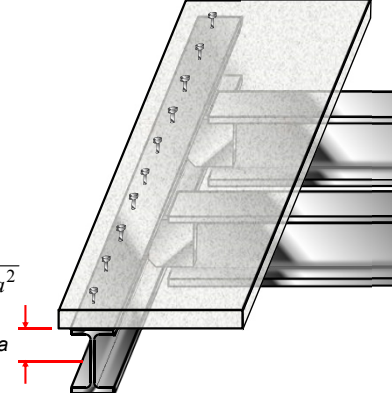
- Constrained-axis flexural-torsional buckling
  - Use  $0.9 P_E$  to calculate  $F_{cr}$

$$P_e = \left[ \frac{\pi^2 E (C_w + I_y a^2)}{(K_z L)^2} + GJ \right] \frac{1}{r_x^2 + r_y^2 + a^2}$$



AISC Seismic Design Manual §8.3
88

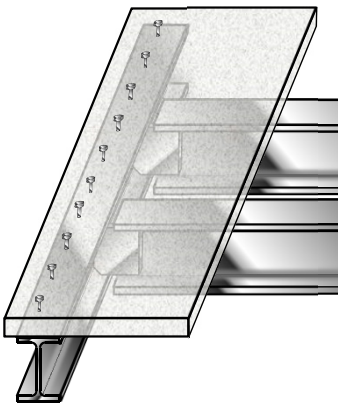

## Beam-columns

- Compressive strength
  - Wide-flange with continuous torsional bracing
    - Major axis flexural buckling
    - Required torsional stiffness
      - Slab stiffness
      - Web stiffness





89

AISC Seismic Design Manual **Table 8-1**  
**Summary of Unbraced Lengths and Restraint Conditions for Collector Beams**  
 (Compressive Strength)

Condition		Major Axis Flexural Buckling Length	Minor Axis Flexural Buckling Length	Constrained-Axis Flexural-Torsional Buckling Length	Torsional Buckling Length
Steel deck	Ribs parallel to beam	Full length	Between lateral brace points	$\leq$	Between torsional brace points
	Ribs perpendicular to beam	Full length	Not applicable (continuously braced)	$\leq$ Between torsional brace points	Not applicable
Composite deck or slab		Full length	Not applicable (continuously braced)	$\leq$ Between torsional brace points <sup>1</sup>	Not applicable <sup>1</sup>
Horizontal diagonal bracing		Full length	Between lateral brace points	$\leq$	Between torsional brace points

## Beam-columns

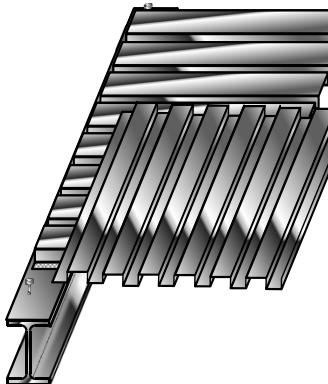
- Flexural strength
  - Composite deck
    - Composite strength
  - Steel deck only
    - Lateral bracing with flutes perpendicular
    - Unbraced with flutes parallel



91

## Collector connections

- Gravity
  - Shear forces
- Seismic
  - Axial forces (horizontal)
    - $\Omega_o E_h$
  - Rotation
    - Gravity
    - Lateral drift

92



### Collector connections

**Limit States**

- Plate Yield & Rupture (J.4)
- Bolt shear (J.3)
- Bearing & Splitting (J.3)
- Block Shear (J.4)
- Weld Rupture (J.2)

AISC 360 Chapter J 93

### Collector connections

$$\left( \frac{H_u}{\phi R_n(x)} \right)^2 + \left( \frac{V_u}{\phi R_n(y)} \right)^2 \leq 1$$

AISC 94

### Collector connections

- Rotation
  - Single-plate connection
    - Follow Manual rules
      - Plate thickness
      - Bolt size
      - Spacing
  - Double column of bolts
    - Extended plate method
    - Proportioning rules

AISC Manual Part 10 95

### Collector connections

- Rotation
  - Welded top flange
    - Introduces some eccentricity
  - Moment connection
    - Attracts moments
    - May have ductility demands
    - Detail for ductility
      - OMF connection in braced frames

AISC 96



There's always a solution in steel.

## Deformation Compatibility



## Necessity

- Inelastic response
  - Large drifts
    - Lateral system
    - Gravity system
- Performance goal
  - Prevent collapse
    - Global
    - Local

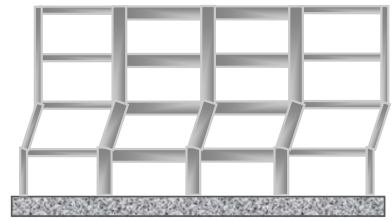



---



ASCE 7 §12.12.5 98

## Gravity connections

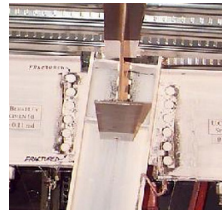
- Connection rotation angle ~ drift angle
- Simple connections in the *Manual* provide inelastic rotation capacity
  - 3% (minimum) for design range
  - Seismic drift assumed to be accommodated
  - No additional justification required





---



AISC Manual Part 10 99

## Flexible diaphragms

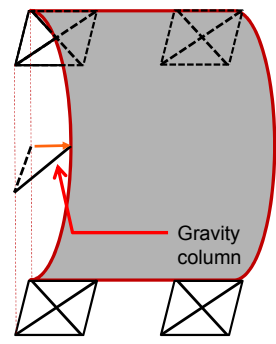
- Diaphragm deformation adds to story drift
- Columns and connections at diaphragm mid-span
  - Increased rotations
  - Increased P-Δ





---



100

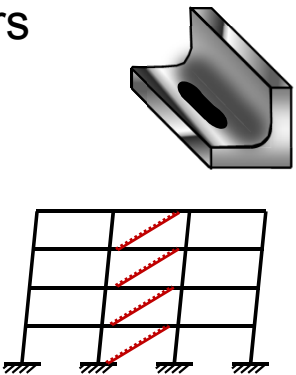

### Stairs



- Act as braces
  - Stiff
- Not ductile
- Continued function necessary
  - $I_p=1.5$
- Detail to allow movement
  - Maintain gravity support

ASCE 7 §13.1.3 101

### Stairs

**One approach:**

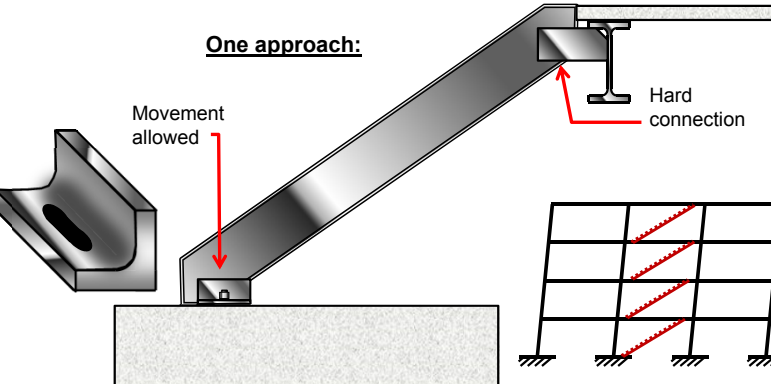

ASCE 7 §12.12.5 102

### Pounding

- Dynamic effects
- Column damage
  - At offset levels

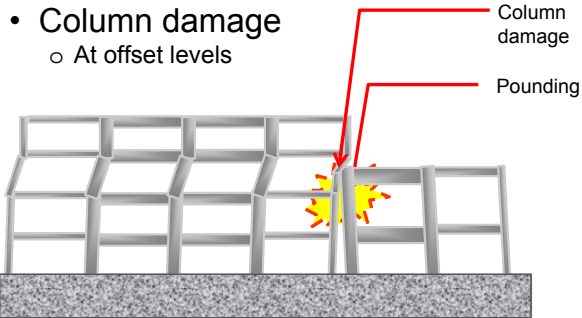

ASCE 7 §12.12.3 103

### Typical seismic separations

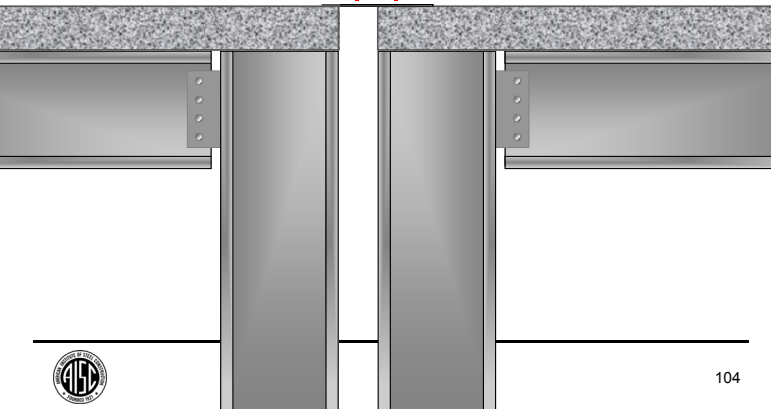

$\sqrt{\Delta_1^2 + \Delta_2^2}$  ASCE 7 §12.12.3 104



### Critical support conditions

- High consequence
  - Loss of gravity support
  - Loss of egress
- Treat with extra care
  - Estimate upper-bound displacements
  - Absolute sum, not SRSS

Member spanning seismic separation  
Support on bracket

105

### Critical support conditions

$1.5\Delta C_d/R$  ← | →  $1.5\Delta C_d/R$

ASCE 7 §12.12.4  
Check bearing adequacy at this eccentricity!

106

### Deformation compatibility

- Shear distortion adjacent to tall frames
  - Due to
    - Lateral drift
    - Column axial deformation
  - May result in large rotation demands

Amplified rotation

ASCE 7 §12.12.5

107

## Wind vs. seismic

There's always a solution in steel.





## Wind vs. seismic



- Efficient design
  - Design for governing case
    - Member selection
  - Check for other cases
    - Simplified checks, where possible
- In many cases different loads govern for different portions
  - e.g., light cladding typically wind-governed

---

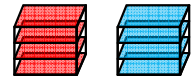

109

## Wind vs. seismic

- Wind
  - Area contributes 
  - ~uniform distribution 
  - Moderate  $M_{ot}/V$
  - No proportioning requirements
  - Serviceability
  - Strength

- Seismic
  - Mass contributes 
  - System dependent
  - Top-heavy distribution 
  - High  $M_{ot}/V$
  - Proportioning requirements
    - $\Omega_o M_{ot}$
  - Drift
  - Strength
  - Stability

---



110

## Wind vs. seismic

- Compare base shear
  - If wind governs base shear, compare
    - Story shears
    - Overturning moments
      - Including  $\Omega_o$ , where applicable
  - If seismic governs
    - Compare required seismic and wind stiffness

- Always check
  - Permitted lateral systems
  - Wind serviceability
  - Wind on light cladding, roof screens
  - Seismic on heavy cladding, mechanical units interior components
  - Seismic stability

---

111

There's always a solution in steel.

## Summary





### Summary

- Design in the US is governed by a system of codes, each with its scope
- ASCE 7 is the principal code for
  - Loads
  - Analysis requirements
  - System limitations



There's always a solution in steel.

### End of session 4

Next:  
**Planning the seismic design**

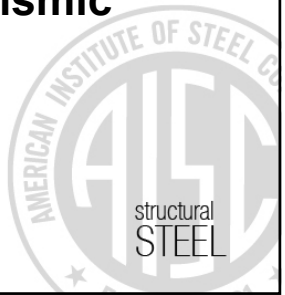

### Additional resources



There's always a solution in steel.

### Question time



### Individual Webinar Registrants

#### CEU/PDH Certificates

Within 2 business days...

- You will receive an email on how to report attendance from: [registration@aisc.org](mailto:registration@aisc.org).
- Be on the lookout: Check your spam filter! Check your junk folder!
- Completely fill out online form. Don't forget to check the boxes next to each attendee's name!



### Individual Webinar Registrants

#### CEU/PDH Certificates

Within 2 business days...

- New reporting site (URL will be provided in the forthcoming email).
- Username: Same as AISC website username.
- Password: Same as AISC website password.



### 8-Session Registrants

#### CEU/PDH Certificates

One certificate will be issued at the conclusion of all 8 sessions.



### 8-Session Registrants

Access to the quiz: Information for accessing the quiz will be emailed to you by Wednesday. It will contain a link to access the quiz. EMAIL COMES FROM NIGHTSCHOOL@AISC.ORG

Quiz and Attendance records: Posted Tuesday mornings. [www.aisc.org/nightschool](http://www.aisc.org/nightschool) - click on Current Course Details.

Reasons for quiz:

- EEU – must take all quizzes and final to receive EEU
- CEUs/PDHS – If you watch a recorded session you must take quiz for CEUs/PDHS.
- REINFORCEMENT – Reinforce what you learned tonight. Get more out of the course.

NOTE: If you attend the live presentation, you do not have to take the quizzes to receive CEUs/PDHS.



### 8-Session Registrants

**Access to the recording:** Information for accessing the recording will be emailed to you by this Wednesday. The recording will be available for three weeks. For 8-session registrants only. EMAIL COMES FROM NIGHTSCHOOL@AISC.ORG.

**CEUs/PDHS** – If you watch a recorded session you must take AND PASS the quiz for CEUs/PDHS.



### Night School Resources for 8-session package Registrants

Find all your handouts, quizzes and quiz scores, recording access, and attendance information all in one place!



### Night School Resources for 8-session package Registrants

Go to [www.aisc.org](http://www.aisc.org) and sign in.



#### Login

If you're an existing customer, please enter your username and password.

Form with fields for USERNAME and PASSWORD, and a Remember Me checkbox.

**DON'T HAVE AN ACCOUNT?**  
My AISC allows you to access Engineering Journal articles and Design Guides you have downloaded from the bookstore.  
[REGISTER NOW](#)

### Night School Resources for 8-session package Registrants

Go to [www.aisc.org](http://www.aisc.org) and sign in.

MyAISC user dashboard with sections: IN THIS SECTION, MY PROFILE, MY PURCHASED DOWNLOADS, and MY COURSE RESOURCES. The 'Course Resources' link and 'MY COURSE RESOURCES' section are circled in red.



### Night School Resources for 8-session package Registrants

**Course Resources**

Event	Start Date
NS 13 8-Session Package-Night School 13- Design of Industrial Buildings	1/30/2017 7:00:00 PM
NS 14 8-Session Package-Night School 14- Fundamentals of Stability	6/5/2017 7:00:00 PM

### Night School Resources for 8-session package Registrants

**Night School 13: Design of Industrial Buildings**

**8-SESSION PACKAGE RESOURCES**

Event	Date	Handouts	Video	Quiz	Attendance
NS13 - Design Criteria	1/30/2017 7:00:00 PM	<a href="#">Handouts</a>	<a href="#">Video</a>	Pass Score: 80	Pending
NS13 - Economic Considerations	2/6/2017 7:00:00 PM	<a href="#">Handouts</a>	Available 02/08/2017 5pm EST	Available 02/08/2017 5pm EST	Pending
NS13 - Lateral Load Systems and Details	2/13/2017 7:00:00 PM	<a href="#">Handouts</a>	Available 02/15/2017 5pm EST	Available 02/15/2017 5pm EST	Pending
NS13 - Preliminary Design Procedures	2/27/2017 7:00:00 PM	<a href="#">Handouts</a>	Available 03/01/2017 5pm EST	Available 03/02/2017 5pm EST	Pending
NS13 - Crane Grider Design and Frame Analysis	3/6/2017 7:00:00 PM	<a href="#">Handouts</a>	Available 03/08/2017 5pm EST	Available 03/08/2017 5pm EST	Pending
NS13 - Frame Member and Connection Design	3/13/2017 7:00:00 PM	<a href="#">Handouts</a>	Available 03/15/2017 5pm EST	Available 03/15/2017 5pm EST	Pending
NS13 - Transfer Crane Grider & Longitudinal Brdg Bracing Dsn	3/27/2017 7:00:00 PM	<a href="#">Handouts</a>	Available 03/29/2017 5pm EST	Available 03/29/2017 5pm EST	Pending
NS13 - Building Envelope and Bracing Design	4/3/2017 7:00:00 PM	<a href="#">Handouts</a>	Available 04/05/2017 5pm EST	Available 04/05/2017 5pm EST	Pending
NS13 - Final Exam	4/30/2017 7:00:00 PM			Available 04/22/2017 5pm EST	

### Night School Resources for 8-session package Registrants

- Weekly “quiz and recording” email.
- Weekly updates of the master Quiz and Attendance record found at [www.aisc.org/night school](http://www.aisc.org/night school). Scroll down to Quiz and Attendance records.
  - Updated on Tuesday mornings.



### Night School Resources for 8-session package Registrants

- Webinar connection information:
  - Found in your registration confirmation/receipt.
  - Reminder email sent out Monday mornings.
- Link to handouts also found here.



There's always a solution in steel.

# Thank You

Please give us your feedback!  
*Survey at conclusion of webinar.*

