



Thank you for joining our live webinar today.
We will begin shortly. Please standby.



Thank you.

Need Help?
Call ReadyTalk Support: 800.843.9166

Today's audio will be broadcast through the internet.



Alternatively, to hear the audio through the phone, dial 866-519-2796. Passcode: 171172

Today's live webinar will begin shortly.
Please standby.

As a reminder, all lines have been muted. Please type any questions or comments through the Chat feature on the left portion of your screen.

Today's audio will be broadcast through the internet.
Alternatively, to hear the audio through the phone, dial 866-519-2796. Passcode: 171172

AISC is a Registered Provider with The American Institute of Architects Continuing Education Systems (AIA/CES). Credit(s) earned on completion of this program will be reported to AIA/CES for AIA members. Certificates of Completion for both AIA members and non-AIA members are available upon request.

This program is registered with AIA/CES for continuing professional education. As such, it does not include content that may be deemed or construed to be an approval or endorsement by the AIA of any material of construction or any method or manner of handling, using, distributing, or dealing in any material or product.

Questions related to specific materials, methods, and services will be addressed at the conclusion of this presentation.





Copyright Materials

This presentation is protected by US and International Copyright laws. Reproduction, distribution, display and use of the presentation without written permission of AISC is prohibited.

© The American Institute of Steel Construction 2018



Course Description

Session 8: Design of the Braced Frames April 16, 2018

This live webinar presents the design of the buckling restrained braced frames including: sizing braces, beam and column design, gusset plate design and connection analysis. The session will also cover plastic mechanism analysis, base plate design and concludes with a course summary.



Learning Objectives

- Describe the steps for the sizing of braces.
- Describe the steps of a plastic mechanism analysis.
- Describe the steps for the design of the beams and columns.
- Describe the steps for the design of the gusset plates.



There's always a solution in steel.

Seismic Design in Steel: Concepts and Examples

Session 3: Design of the Braced Frames
April 16, 2018

Rafael Sabelli, SE

Course objectives

- Understand the principles of seismic design of steel structures.
- Understand the application of those principles to two common systems:
 - Special Moment Frames
 - Buckling-Restrained Braced Frames.
- Understand the application of design requirements for those systems.



9

Resources

- AISC *Seismic Design Manual*
- *Ductile Design of Steel Structures*, Bruneau, Uang, and Sabelli, McGraw Hill.
- *Earthquakes and Seismic Design, Facts for Steel Buildings #3*. Ronald O. Hamburger, AISC.
- Other publications suggested in each session

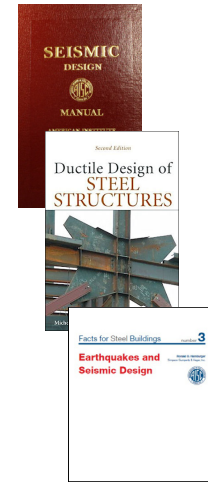

10

Other resources

- AISC Solutions Center
 - 866.ASK.AISC (866-275-2472)
 - Solutions@AISC.org
- AISC Night School
 - Nightschool@AISC.org



11

Course outline

Part I: Concepts

1. Introduction to effective seismic design
2. Seismic design of moment frames
3. Seismic design of braced frames
4. Seismic design of buildings



12

Course outline

Part II: Application

- 5.Planning the seismic design
- 6.Building analysis and diaphragm design
- 7.Design of the moment frames
- 8.Design of the braced frames**



There's always a solution in steel.

Session 8: Design of the braced frames

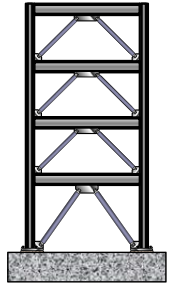

Session topics

- Buckling-restrained brace sizing
- Plastic mechanism analysis
- Column and beam design
- Final analysis
- Gusset connections
- Base plate design
- Improved performance
- Course summary



BRBF design overview

- | | |
|--|--|
| <ul style="list-style-type: none"> • Compute demands using design base shear • Size braces (fuses) • Compute maximum brace forces • Perform plastic mechanism analysis | <ul style="list-style-type: none"> • Size beams and columns for PMA forces • Final analysis <ul style="list-style-type: none"> ○ Confirm period ○ Determine drift • Design connections |
|--|--|



There's always a solution in steel.

Brace sizing



Braced-frame model

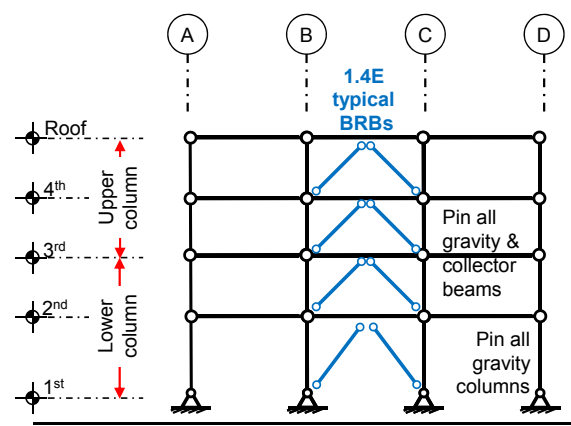

Pin braces
 Pin beams and columns
 Pin all gravity & collector beams
 Pin all gravity columns
 Pin column bases

18

Braced-frame forces

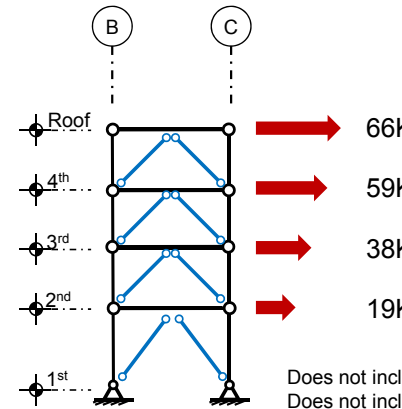

66K
 59K
 38K
 19K

Does not include $\rho=1.3$
 Does not include B_2

Forces derived in sessions 5 & 6

19

Braced-frame forces

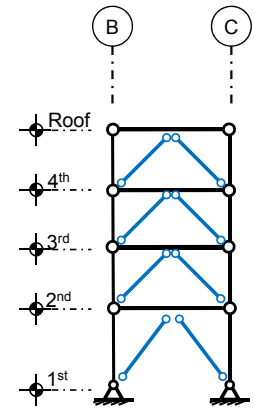

As an alternative to introducing pins in the model, the analysis results can be examined to confirm that the braces resist close to 100% of the required base shear. Brace forces can be adjusted upwards if necessary

Level	Frame F_{xs} (kips)	B_2	ρ	Frame $\rho B_2 F_{xs}$ (kips)	Frame $\rho B_2 V_{xs}$ (kips)
Roof	66.0	1.02	1.30	87.6	88
4 th	59.2	1.03	1.30	79.3	167
3 rd	38.3	1.03	1.30	51.3	218
2 nd	18.7	1.04	1.30	25.3	243

Forces, ρ , B_2 derived in sessions 5 & 6

20

Force-based design

$$P_u = \frac{V}{2 \cos \theta}$$

• Assume braces resist 100% of story shear V

$$A_{sc} = \frac{P_u}{\phi F_y}$$

Design braces precisely to calculated capacity
 $(P_u = \phi P_n = \phi F_y A_{sc})$

Do not include gravity load

AISC 341 EQ F4-1
21

Brace design

- Specifying area
 - “ $A_{sc} = 5.00 \text{ in}^2$ ”
 - Allow
 - $38 \text{ ksi} \leq F_y \leq 46 \text{ ksi}$
 - Determine area
 - Based on $F_y \geq 38 \text{ ksi}$
 - Determine expected brace strength
 - Based on $R_y F_y = 42 \text{ ksi}$

- Specifying strength
 - “ $\phi P_{sc} = 200 \text{ K}$ ”
 - Allow
 - $38 \text{ ksi} \leq F_y \leq 46 \text{ ksi}$
 - Determine area for model
 - Based on $R_y F_y = 42 \text{ ksi}$
 - Determine expected brace strength
 - Based on $R_y F_y A_{sc} = P_{sc}$
 - i.e., $R_y = 1.0$
 - Use $R_y = 1.05$ for tolerance

22

Brace sizes

From brace manufacturer:
 $38 \text{ ksi} \leq F_y \leq 46 \text{ ksi}$
 Use $F_y = 38 \text{ ksi}$

Level	Brace Force $\rho B_2 P_x$, (kips)	Required core area A_{sc} , (in^2)	Design core area A_{sc} , (in^2)
4 th	62	1.81	2.00
3 rd	118	3.45	3.50
2 nd	154	4.51	5.00
1 st	183	5.34	5.50

Typically rounded up $\leq 10\%$
 For example, $\frac{1}{4} \text{ in}^2$ typically used up to 5 in^2 , $\frac{1}{2} \text{ in}^2$ up to 10 in^2 , etc.

23

There's always a solution in steel.

Plastic mechanism analysis

Plastic mechanism analysis

- Determine maximum brace forces
- Determine vertical and horizontal components
- Apply components to frame
 - Use spreadsheet, or
 - Use temperature (or stress) based analysis

25

Maximum brace forces

- Based on testing
 - $\omega = T_{max}/A_g F_y$
Typical $1.3 \leq \omega \leq 1.5$
 - $\beta\omega = C_{max}/A_g F_y$
Typical $1.1 \leq \beta \leq 1.2$
- For design
 - $R_u(\text{tension}) = \omega A_g R_y F_y$
 - $R_u(\text{compression}) = \beta \omega A_g R_y F_y$

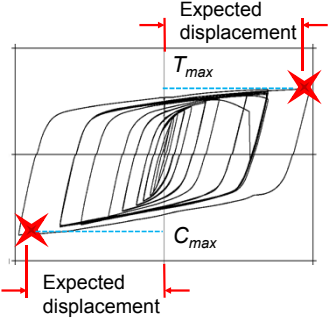



AISC 341 F4.2a
26

Maximum brace forces

- Based on testing
 - May vary with manufacturer
- Based on deformation demands
 - Drift not known at this stage
 - Drift subject to change during design
 - Don't be overly precise
- Use reasonably liberal values for frame design
 - $\beta = 1.15$
 - Tends to be more than this for longer & larger braces
 - $\omega = 1.4$
 - $R_y F_y = 42\text{ksi}$
 - $\beta\omega R_y F_y = 67.6\text{ksi}$
 - $\omega R_y F_y = 58.8\text{ksi}$

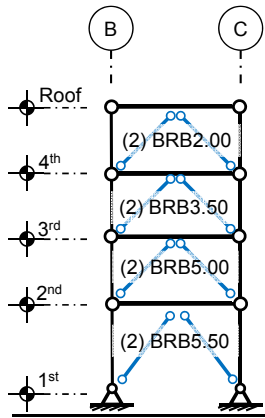

27

Maximum brace forces



From brace manufacturer:
 $\beta\omega R_y F_y = 67.6\text{ksi}$
 $\omega R_y F_y = 58.8\text{ksi}$

Level	Design core ² area A_{sc} , (in ²)	Tension Brace Force $\omega R_y F_y A_{sc}$, (kips)	Compression Brace Force $\beta\omega R_y F_y A_{sc}$, (kips)
4 th	2.00	118	135
3 rd	3.50	206	237
2 nd	5.00	294	338
1 st	5.50	323	372

28

Maximum brace forces

From brace manufacturer:
 $\beta \omega R_y F_y A_{sc} = 67.6 \text{ ksi}$
 $\omega R_y F_y = 58.8 \text{ ksi}$

Level	Required Brace Strength P_u (kips)	Tension overstrength $\omega R_y F_y A_{sc} / P_u$	Compression overstrength $\beta \omega R_y F_y A_{sc} / P_u$
4 th	62	1.90	2.18
3 rd	118	1.74	2.01
2 nd	154	1.91	2.19
1 st	183	1.77	2.03

Use of 2.19E OK for seismic axial forces, but will not capture beam flexure due to β .

29

A little trigonometry

30

Maximum brace forces

Level	Tension Brace Force $\omega R_y F_y A_{sc}$ (kips)	Tension Brace x component (kips)	Tension Brace y component (kips)
4 th	118	83	83
3 rd	206	146	146
2 nd	294	208	208
1 st	323	215	241

Level	Compression Brace Force $\beta \omega R_y F_y A_{sc}$ (kips)	Compression Brace x component (kips)	Compression Brace y component (kips)
4 th	135	96	96
3 rd	237	167	167
2 nd	338	239	239
1 st	372	248	277

Plastic mechanism analysis

Level	Tension Brace x component (kips)	Tension Brace y component (kips)
4 th	83	83
3 rd	146	146
2 nd	208	208
1 st	215	241

Level	Compression Brace x component (kips)	Compression Brace y component (kips)
4 th	96	96
3 rd	167	167
2 nd	239	239
1 st	248	277

32

Plastic mechanism analysis

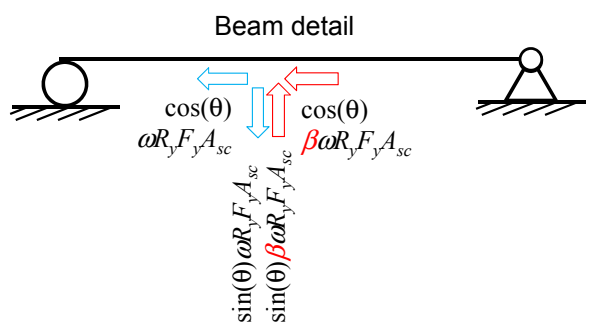

Plastic mechanism analysis

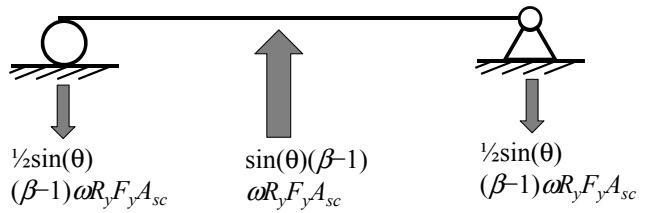

$$V_{Ecl} = \frac{1}{2} \sin(\theta) (\beta - 1) \omega R_y F_y A_{sc}$$

$$M_{Ecl} = \frac{1}{2} V_{Ecl} L$$



Plastic mechanism analysis

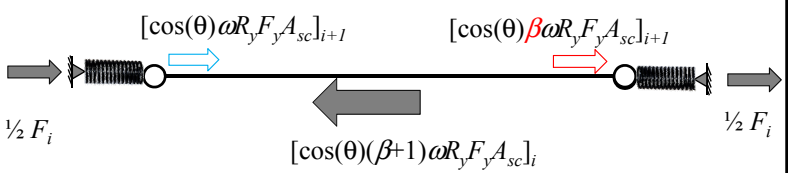

$$P_{Ecl} = \frac{1}{2} [\cos(\theta) (\beta + 1) \omega R_y F_y A_{sc}]_i \pm \frac{1}{2} [\cos(\theta) (\beta - 1) \omega R_y F_y A_{sc}]_{i+1}$$

Plus for tension
 (Minus for compression, but it's unconservative to reduce compression based on β)

Take as: $P_{Ecl} = [\cos(\theta) \beta \omega R_y F_y A_{sc}]_i$ ~8% conservative in this example



$$F_i = [[\cos(\theta) (\beta + 1) \omega R_y F_y A_{sc}]_i - [\cos(\theta) (\beta + 1) \omega R_y F_y A_{sc}]_{i+1}]$$

Plastic mechanism analysis

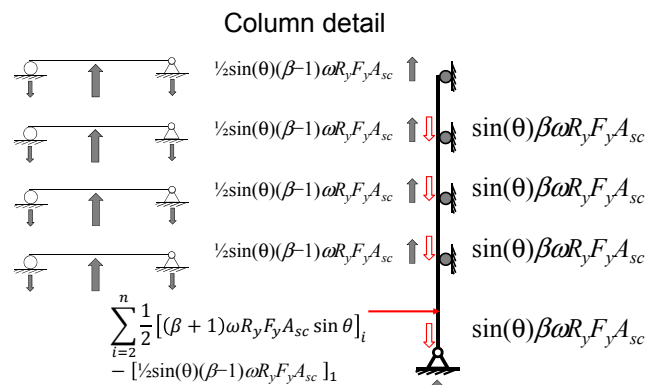

$$\sum_{i=2}^n \frac{1}{2} [(\beta + 1) \omega R_y F_y A_{sc} \sin \theta]_i - [1/2 \sin(\theta) (\beta - 1) \omega R_y F_y A_{sc}]_1$$

$$\sum \frac{1}{2} (\beta + 1) \omega R_y F_y A_{sc} \sin \theta$$



Plastic mechanism analysis

Column detail

37

Column design

There's always a solution in steel.

Plastic mechanism analysis

Level	Tension Brace y component (kips)	Compression Brace y component (kips)
4 th	83	96
3 rd	146	167
2 nd	208	239
1 st	241	277

Level	Column tension force <i>E_{cl}</i> (kips)	Column compression force <i>E_{cl}</i> (kips)
4 th	6	-6
3 rd	100	78
2 nd	261	230
1 st	487	451
Base	729	729

39

Column design

- Axial loads
 - $P_D = 147K$
 - $P_L = 60.0K$
 - $P_{Ecl} = 451K$
 - $P_{Ecl} = 487K$
- Compression
 - $R_u = 1.4D + 0.5L + E_{cl}$
 - $R_u = 687K$
- Tension
 - $R_u = 0.7D + E_{cl}$
 - $R_u = 384K$

Use W10x77
 $\phi P_n = 753K$ (Manual Table 4-1)
 Seismically compact (SDM Table 1-3)

40

Member Selection

- Compactness
 - Use SDM table
 - AISC 341-16 permits moderately ductile members for BRBF beams and columns
 - Use IMF column

Table 1-3 (continued)
 Sections That Satisfy Seismic Width-to-Thickness Requirements
 $F_y = 50$ ksi

Shape	ERF		BRBF	SPSW	P_{max} , kips ASD		P_{max} , kips LRFD		Web Access Holes
	Diagonal Braces	Columns	Links Beams and Columns	HBE and VBE	λ_{inf}	λ_{top}	λ_{inf}	λ_{top}	
W10x112	•	•	•	•	—	—	—	—	D
>x100	•	•	•	•	—	—	—	—	D
>x88	•	•	•	•	—	—	—	—	D
>x77	•	•	•	•	—	—	—	—	C
>x68	•	•	•	•	—	—	—	—	C
>x60	•	•	•	•	—	—	—	—	C
>x54	•	•	•	•	—	—	—	—	B
>x49	•	•	•	•	—	—	—	—	A or B



There's always a solution in steel.

Beam design

Plastic mechanism analysis

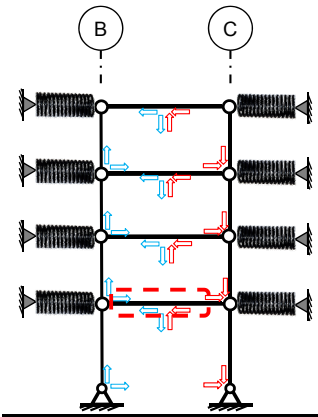

Level	Beam axial force E_{cl} (kips)	Beam shear force E_{cl} (kips)	Beam moment E_{cl} (ft-kips)
Roof	96	6.2	78
4 th	167	10.9	136
3 rd	239	15.6	195
2 nd	248	18.1	226

$$P_{Ecl} = \cos(\theta) \beta \omega R_y F_y A_{sc}$$

$$V_{Ecl} = \frac{1}{2} \sin(\theta) (\beta - 1) \omega R_y F_y A_{sc}$$

$$M_{Ecl} = \frac{1}{2} V_{Ecl} L$$



Beam design

- Shear
 - $V_D = 11.2K$
 - $V_L = 8.5K$
 - $V_E = -18.1K$
 - $V_u = 0.7D + E_{cl} = -10.3K$
- Axial
 - $P_D = 0K$
 - $P_L = 0K$
 - $P_E = 248K$
 - $P_u = 248K$
- Moment
 - $M_D = 120'K$
 - $M_L = 100'K$
 - $M_E = -226'K$
 - $M_u = 0.7D + E_{cl} = -142'K$

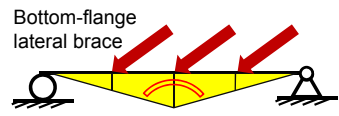

Beam design

- W18x55
 - Shear
 - $\phi V_n = 212K > V_u$ OK
 - Check chevron connection
 - Moment
 - $\phi M_n = 417'K$
 - Table 3-10
 - $L_b = 6'$
 - $C_b = 1$
 - $C_b = 1.25$ (for $M_2 = 2M_1$)
 - $(1.25) 417'K = 521'K$
 - $\phi M_p = 420'K$
 - $\phi M_n = \phi M_p = 420'K$

$$L_g \geq \frac{2(P_1 + P_2) \cos \theta e_b}{\phi V_n}$$

• $L_g \geq 40" < L_6 = 48" \text{ OK}$ (rule of thumb)

$$V_u = \frac{2(P_1 + P_2) \cos \theta e_b}{L_g}$$

Chevron check illustrated in connection design. However, it should be considered in member selection.

45

Member Selection

- Compactness
 - Use SDM Table
 - AISC 341-16 permits moderately ductile members for BRBF beams and columns
 - Use IMF column

Shape	W-Shapes										Web Access Holes
	EBF		BRBF Beams and Columns	SPSW	ASD		LRFD		Web		
	Diagonal Braces	Columns			λ_{max}	λ_{min}	λ_{max}	λ_{min}	Access	Holes	
W21	•	•	•	•	217	307	326	461	•	B	
>50	•	•	•	•	117	219	176	330	•	A or B	
>44	•	•	•	•	38.3	133	57.6	201	•	A or B	
W18	•	•	•	•	—	—	—	—	•	F	
>211	•	•	•	•	—	—	—	—	•	H	
>258	•	•	•	•	—	—	—	—	•	G	
>234	•	•	•	•	—	—	—	—	•	F	
>211	•	•	•	•	—	—	—	—	•	F	
>192	•	•	•	•	—	—	—	—	•	E	
>175	•	•	•	•	—	—	—	—	•	D	
>158	•	•	•	•	—	—	—	—	•	D	
>143	•	•	•	•	—	—	—	—	•	C	
>130	•	•	•	•	—	—	—	—	•	C	
>119	•	•	•	•	—	—	—	—	•	C	
>106	•	•	•	•	—	—	—	—	•	C	
>97	•	•	•	•	—	—	—	—	•	C	
>86	•	•	•	•	—	—	—	—	•	C	
>76	•	•	•	•	595	620	895	932	•	C	
W18	•	•	•	•	—	—	—	—	•	C	
>71	•	•	•	•	—	—	—	—	•	C	
>65	•	•	•	•	—	—	—	—	•	C	
>60	•	•	•	•	444	472	668	709	•	C	
>55	•	•	•	•	346	391	520	588	•	B	
>50	•	•	•	•	217	288	326	433	•	A or B	
W18	•	•	•	•	212	273	319	416	•	B	
>46	•	•	•	•	65.4	158	98.3	146	•	A or B	
>40	•	•	•	•	30.9	107	46.5	161	•	A or B	
>35	•	•	•	•	—	—	—	—	•	A or B	

48

Beam design

- $B_1 = \frac{C_m}{1 - P_u/P_{E1}} \geq 1$
 - Assume $C_m = 0.8$ ($M_1/M_2 = -2$)
 - $C_m < 0.6$
 - $C_m = 0.6$
 - $C_m > 0.6$
 - $C_m = 1.0$
- $P_{E1} = \frac{\pi^2 EI}{L^2} = 45,300K$ If $C_m = 0.8$
- $B_1 = 1$ $B_1 = 1$ for $P_u \leq 0.2P_{E1}$

47

Beam design

- Axial
 - $KL/r_y = 75"/1.67" = 44.9$
 - $\phi F_{cr} = 38.8\text{ksi}$
 - Table 4-22
 - $\phi F_{cr} A = 629K$
- Chapter H Interaction
 - $P_u / \phi F_{cr} A = 0.39$
 - $P_u / \phi F_{cr} A + 8/9 M_u / \phi M_n = 0.39 + 8/9(142'K/420'K) = 0.69 \text{ OK}$

48

There's always a solution in steel.

Final analysis

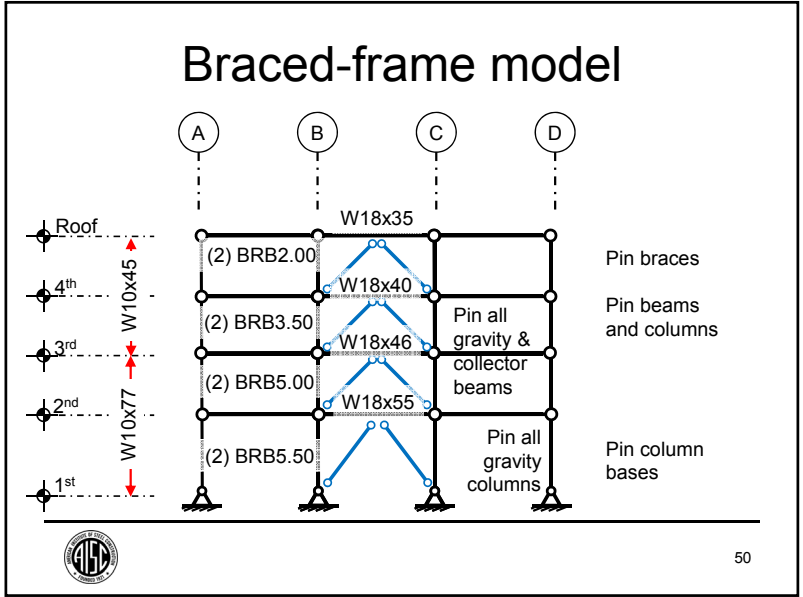



Brace stiffness

- Consult manufacturer
 - Direct communication
 - Brochure

Level	Design core area A_{sc} (in ²)	Workpoint length (ft)	Stiffening factor
4 th	2.00	17.7	1.39
3 rd	3.50	17.7	1.39
2 nd	5.00	17.7	1.43
1 st	5.50	18.8	1.46

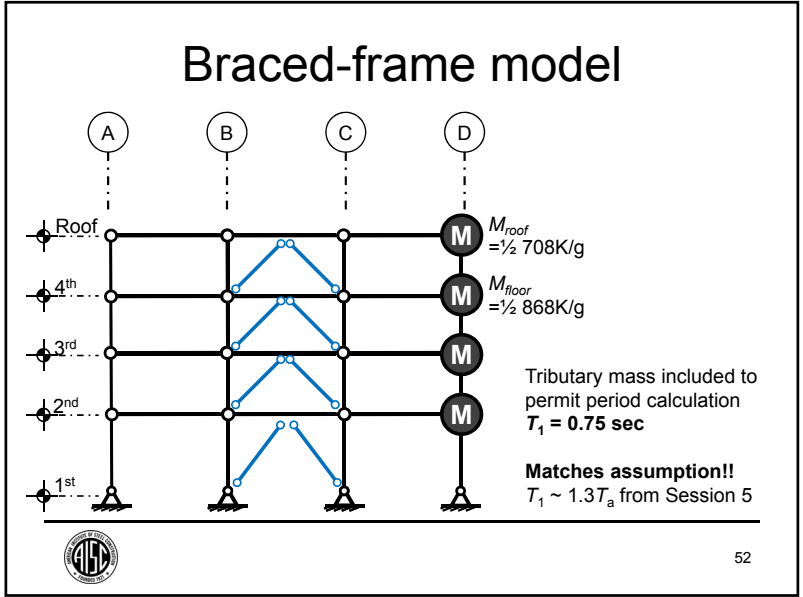
51



Drift

- Obtain from model
- Recalculate B_2
- Amplify drift for second-order effects
 - Only necessary per ASCE 7 if $\theta > 0.1$ ($B_2 > 1.1$)
 - Preferable not to modify process for $B_2 < 1.1$

Level	Model drift (%)	B_2	Drift* B_2
4 th	1.76%	1.02	1.80%
3 rd	1.68%	1.02	1.71%
2 nd	1.60%	1.03	1.65%
1 st	1.36%	1.03	1.40%



53

Check irregularities

- Horizontal torsional irregularity
 - Same check as initial
 - Lines A & D identical
 - Lines 1 & 5 identical
 - $\Delta_5 \leq 1.1\Delta_{ave}$ (up to 1.2 OK)
 - Irregularity not present

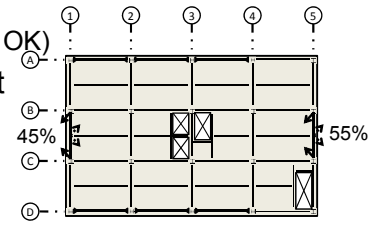

54

Check irregularities

- Vertical soft story
 - Results from model
- | Level | Displacement (in.) | Shear (kips) | Stiffness (kips/in) |
|-----------------|--------------------|--------------|---------------------|
| 4 th | 0.528 | 66.0 | 125 |
| 3 rd | 0.504 | 125.2 | 248 |
| 2 nd | 0.480 | 163.6 | 341 |
| 1 st | 0.457 | 182.3 | 399 |
- Story stiffness increases with story shear
 - Irregularity not present



(at least 70% of the stiffness above)

55

Check irregularities

- Vertical weak story
 - Brace strength

Level	Design core area A_{sc} (in ²)	Tension Brace Force $\omega R_y F_y A_{sc}$ (kips)	Compression Brace Force $\beta \omega R_y F_y A_{sc}$ (kips)	Story shear strength (kips)
4 th	2.00	118	135	358
3 rd	3.50	206	237	626
2 nd	5.00	294	338	894
1 st	5.50	323	372	926

- Story strength increases with story shear
- Irregularity not present



(at least 80% of the stiffness above)

56





There's always a solution in steel.

Gusset connections

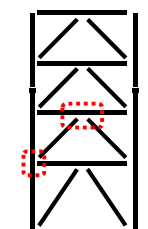

Gusset connection

- Beam-column-brace connection
 - Rotation approach
 - Configuration
 - Gusset design
 - Beam-to-gusset connection
- Chevron connection
 - Minimum length
 - Local forces
 - Gusset design

58

Gusset connection

- Manufactured braces
 - Manufacturer-designed brace to gusset connection
 - Gusset thickness relates to BRB core plate thickness
 - Manufacturer can assist with gusset connection to beam & column
- EOR
 - Remains responsible for structure
 - Must communicate
 - Non-brace forces at connection
 - Beam shear
 - Column shear?
 - Load path restrictions
 - Especially at base plates





59

Gusset connection

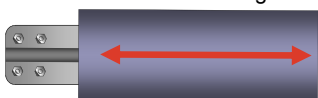
- Brace-to-gusset connections
 - Check manufacturer's design
 - (4)1"Ø A490X bolts
 - Double shear
 - 3/4" A572 Gr. 50 gusset

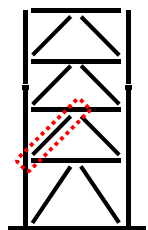

$P_u = 338K$ (compression)
 $P_u = 294K$ (tension)

60

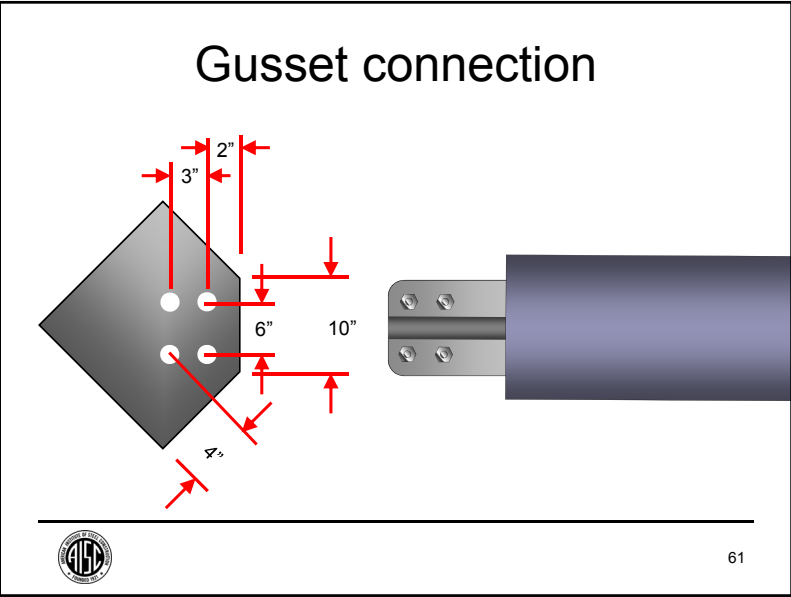

Gusset connection

- Compression
 - $R_u = 338K$
 - Bolt shear
 - (Table 7-1)
 - $\phi R_n = 4 * 98.9K = 396K$
 - Bearing (spacing)
 - (Table 7-4)
 - $\phi R_n = 4 * 3/4 * 113K = 339K$
- Tension
 - $R_u = 294K$
 - Bearing (edge distance)
 - (Tables 7-4 & 7-5)
 - $\phi R_n = 2 * 3/4 * 113K$
 - $+ 2 * 3/4 * 85.9K = 298K$

62

Gusset connection

- Block shear
 - $R_n = 0.6F_u A_{nv} + U_{bs} F_u A_{nt} \leq 0.6F_y A_{gv} + U_{bs} F_u A_{nt}$
 - $0.6(65\text{ksi})(5.53\text{in}^2) + (1.0)(65\text{ksi})(3.84\text{in}^2) = 466K$
 - $0.6(50\text{ksi})(7.5\text{in}^2) + (1.0)(65\text{ksi})(3.94\text{in}^2) = 475K$
 - $\phi R_n = 0.75(466K) = 349K$

AISC 360 §J.4 63

Beam-column-brace connection

There's always a solution in steel.

Beam-column-brace connection

- Mega-gusset
 - Beam connection outside gusset
 - Follow "simple connection" limits to allow for rotation
 - Flange plates
 - Stability
 - Deck support
 - Eccentric moment on column

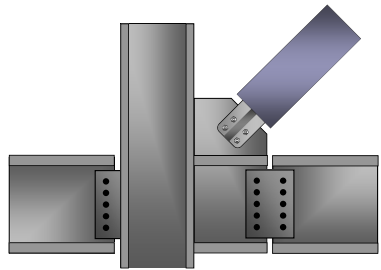

65

Beam-column-brace connection

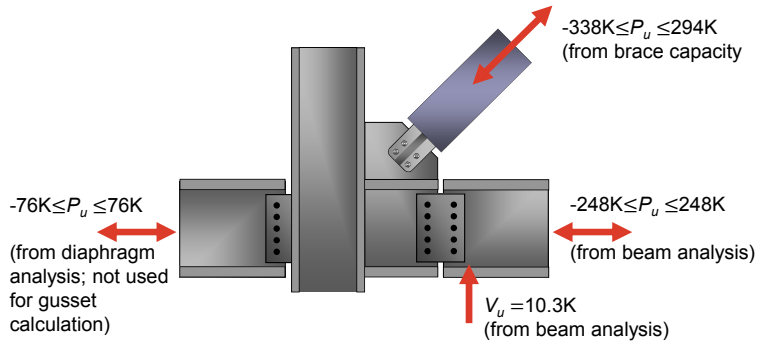

66

Gusset connection trigonometry

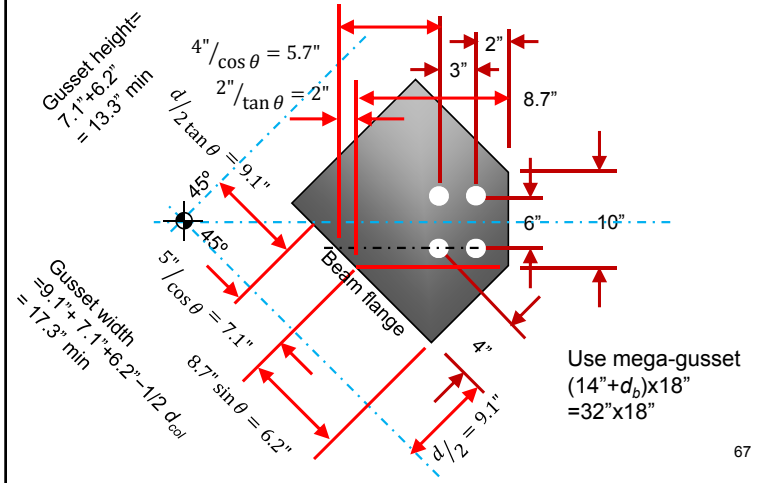

67

Beam-column-brace connection

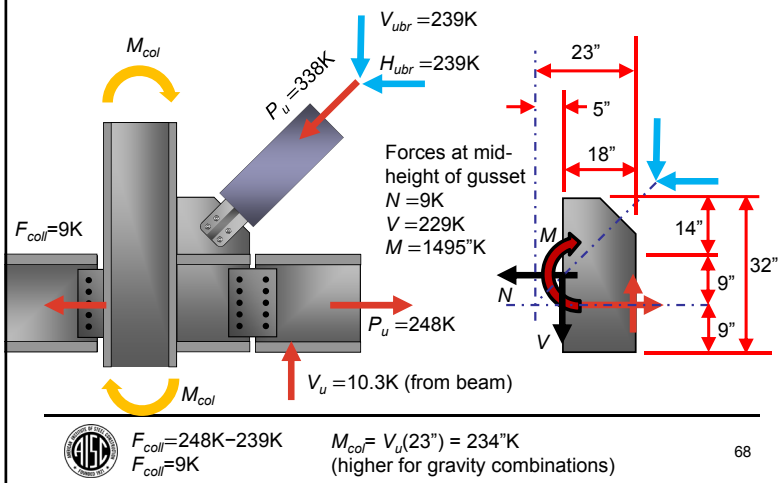

68

Beam-column-brace connection

$V = 229K$
 $f_v = \frac{229k}{(0.75in)(32in)} = 9.5ksi$
 $N = 9K$
 $f_a = \frac{9k}{(0.75in)(32in)} = 0.4ksi$
 $M = 1495"K$
 $f_b = \frac{4 * 1495"K}{(0.75in)(32in)^2} = 7.8ksi$

Plate:

 $f_e = \sqrt{(f_a + f_b)^2 + 3f_v^2} = 22.7ksi < \phi F_y$

AISC Manual EQ 9-1
69

Beam-column-brace connection

- Weld:
 - $e = M/V = 6.5"$
 - (ignore small N)
 - $a = e/L = 6.5"/32" = 0.20$
 - Table 8-4
 - Angle = 0°
 - $k=0$ for out-of-plane
 - $C = 3.51K/in / (1/16in)$
 - $D \geq 229 / (0.75 * 3.51 * 32)$
 - $D \geq 2.7, x1.25 = 3.4$
 - Use (2) $5/16"$ fillet welds

70

Beam-column-brace connection

- Check gusset compactness
 - Per Dowswell (2006 AISC Engineering Journal)

$t_B = 1.5 \sqrt{\frac{F_y c^3}{EL_1}} = 1.5 \sqrt{\frac{(50 ksi)(4 in)^3}{(29,000 ksi)(5.7 in)}}$
 $= 0.14 in \leq 0.75 in$

- Gusset is compact
- No further stability evaluation required

71

Beam-column-brace connection

- Check column
 - WLY, WC
 - Forces
 - $R_u = M / (1/2h) + 1/2N = 98K$
 - $N_{bearing} = 1/2h = 16"$
 - (evaluation not presented)

72

Beam-column-brace connection

- o Panel Zone
 - $R_v = M/(1/2h)$
 = 93K
 - $\frac{P_u}{P_y} = \frac{687K}{(50ksi)(22.7in^2)} = 0.6$
 - $\phi R_n = 0.9 * 0.6F_y t_w d \left(1.4 - \frac{P_u}{P_y} \right)$
 = 121K OK

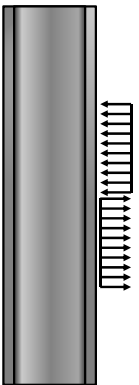

Beam-column-brace connection

- Double plate connection
 - o (5) 7/8" Ø A325X bolts
 - At beam
 - At gusset
 - o Double shear
 - o (2) 3/8" A572 Gr. 50 plates
 - 15"x12"
 - o Tack welds for erection
 - o See collector connection calculations
 - o Reinforce beam web

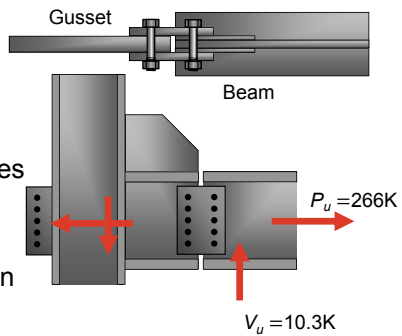

Beam-column-brace connection

- Double plate connection
 - o Meets limits for single plate connection
 - #bolts = 5 ≤ 12
 - Bolt-to-weld distances ≤ 3 1/2"
 - o Bolt-line-to-bolt-line distances ≤ 7"
 - STD holes
 - Horizontal edge distance
 - o $L_{eh} \geq 2d$
 - Maximum plate thickness
 - o $d/2 + 1/16" = 1/2"$

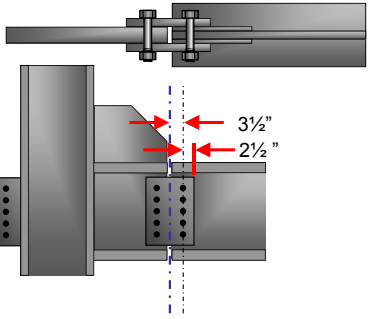

Extended configuration procedure available beyond these limits

Chevron connection

There's always a solution in steel.



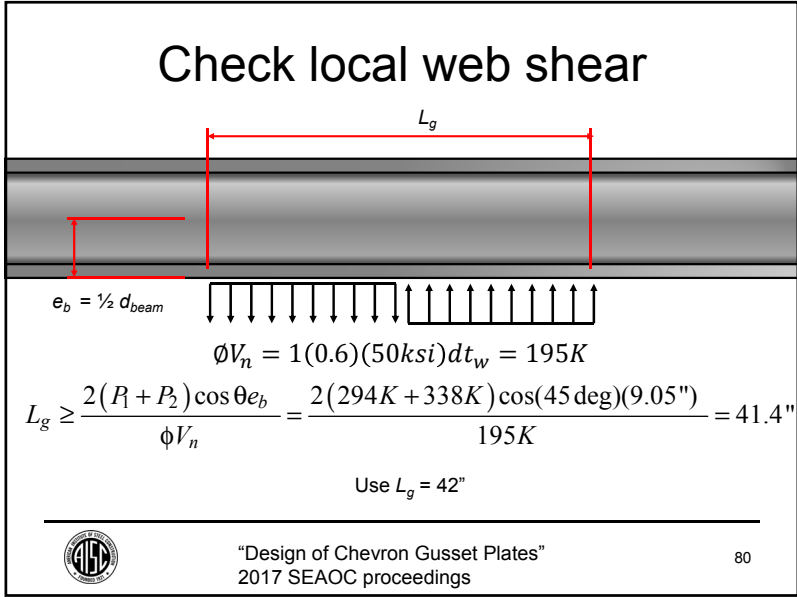
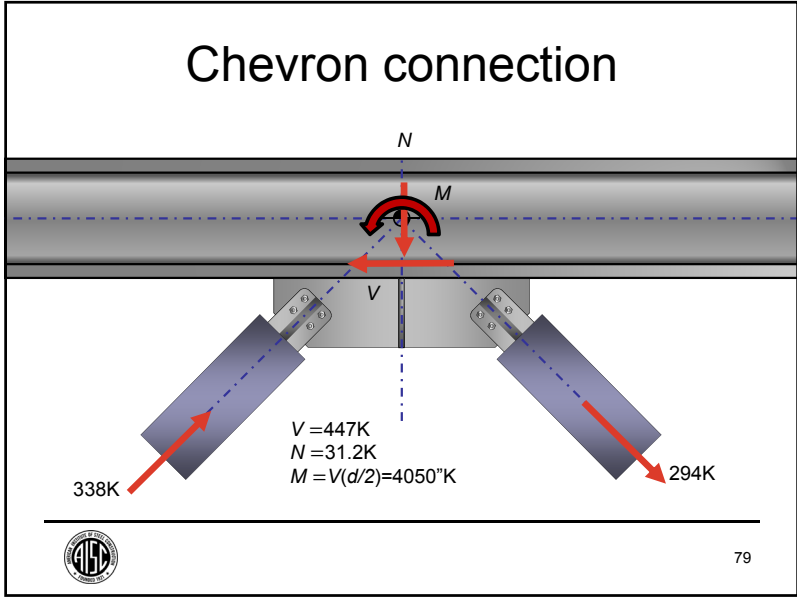
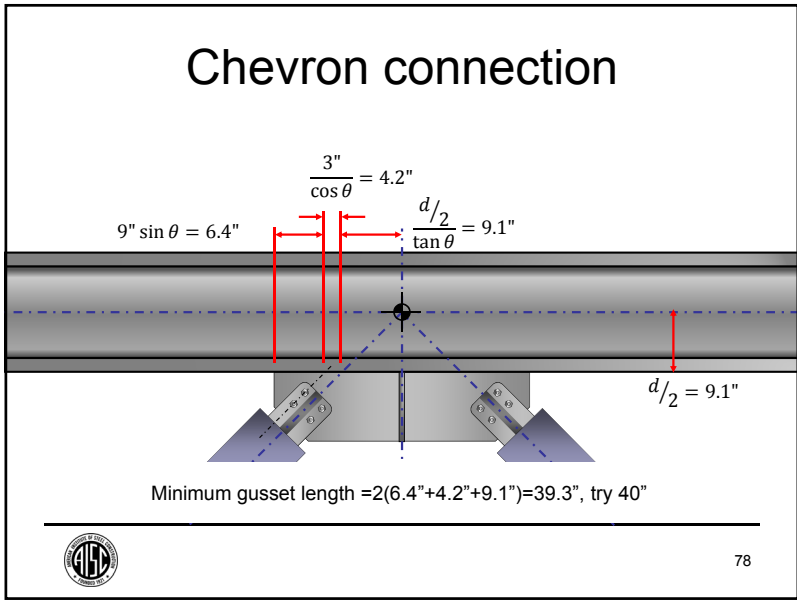
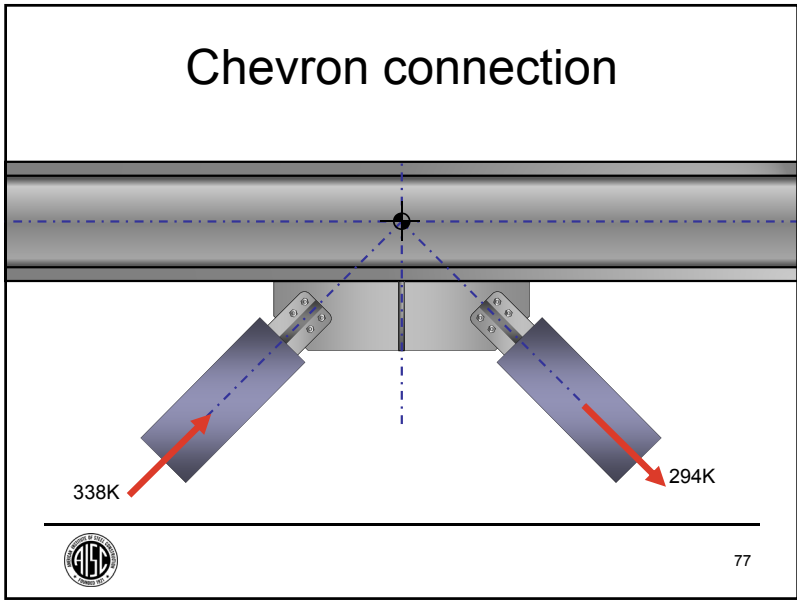

Chevron connection

$V = 447K$

$$f_v = \frac{447k}{(0.75in)(42in)} = 14.2ksi$$

$N = 31K$

$$f_a = \frac{31k}{(0.75in)(42in)} = 1.0ksi$$

$M = 4050^{\circ}K$

$$f_b = \frac{4 * 4050^{\circ}K}{(0.75in)(42in)^2} = 12.2ksi$$

$V = 447K$
 $N = 31.2K$
 $M = V(d/2) = 4050^{\circ}K$

$$f_e = \sqrt{(f_a + f_b)^2 + 3f_v^2} = 28ksi < 0F_y$$

von Mises effective stress

81

Chevron connection

- Weld:
 - $e = M/V = 9.1"$
 - (ignore small N)
 - $e/L = 9.1"/42" = 0.23$ Table 8-4
 - Angle = 0°
 - $k=0$
 - $C = 3.31K/in/(1/16in)$
 - $D \geq 447/(0.75 * 3.51 * 42)$
 - $D \geq 4.3, x1.25 = 5.4$
 - Use (2) $3/8"$ fillet welds

82

Chevron connection

- Check beam
 - WLY
 - WC
 - Forces
 - $R_u = M/(1/2L_g) + 1/2N$
 $= 208K$
 - $N_{bearing} = 1/2L_g = 21"$
 - (evaluation not presented)

83

Chevron connection

- Provide torsional bracing at chevron connection
 - AISC 341 F4.4a(2)

BRBF beam

Chevron gusset

Supported beam providing torsional bracing

84

There's always a solution in steel.

Base plate



Base-plate design

- Maximum forces from plastic mechanism analysis
- Use anchor rods for tension
- Do not use anchor rods for shear
- Provide rotational ductility
- Is the manufacturer assisting with gusset design?
 - Specify if base plate is designed to resist vertical gusset force



86

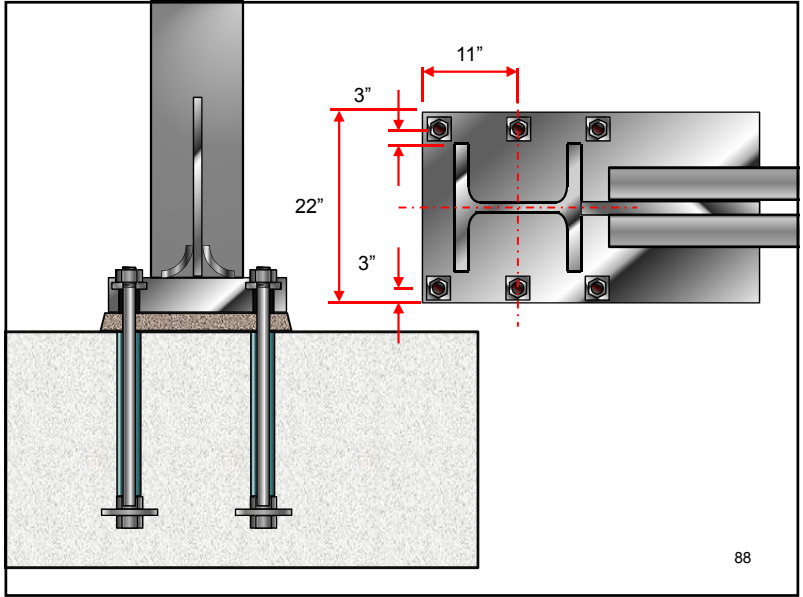
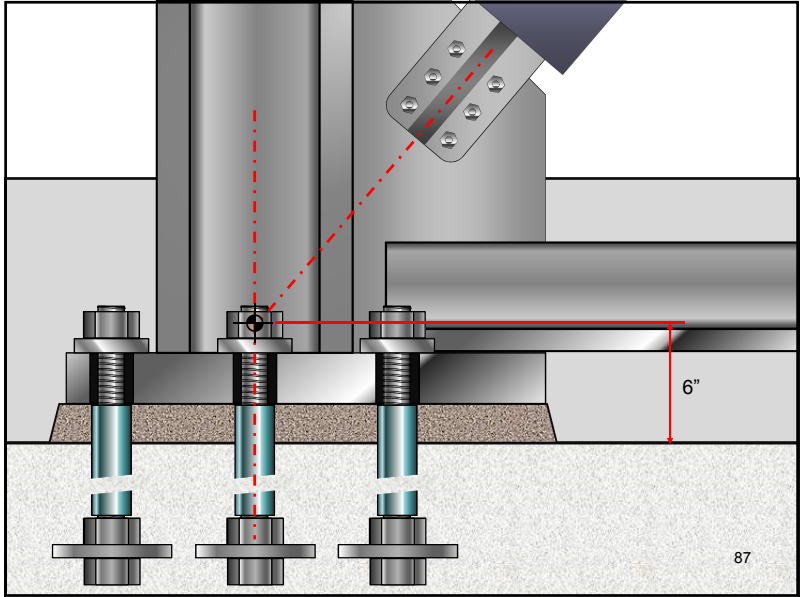

Base-plate design

- Tension
 - Size rods
 - Check plate bending
 - Rotational ductility
 - Anchor rods
 - Base plates
 - Column rotation
 - Foundation rotation
- Compression
 - Check bearing
 - Check plate bending
 - Rotational ductility
 - Column rotation
 - Foundation rotation
 - Base plates and anchor rods will not provide rotation



Base-plate design

- Axial loads
 - $P_D = 147K$
 - $P_L = 60.0K$
 - $P_{Ecl} = 729K$
- Compression
 - $R_u = 1.4D + 0.5L + E_{cl}$
 - $R_u = 965K$
- Tension
 - $R_u = 0.7D + E_{cl}$
 - $R_u = 626K$

Level	Column tension force E_{cl} (kips)	Column compression force E_{cl} (kips)
4 th	6	-6
3 rd	100	78
2 nd	261	230
1 st	487	451
Base	729	729



Base-plate design

- Shear loads
 - Brace in tension
 - $V_{Ecl} = 215K$
 - Brace in compression
 - $V_{Ecl} = 248K$

Level	Tension Brace Force $\omega R_y F_y A_{sc}$ (kips)	Tension Brace x component (kips)	Tension Brace y component (kips)
4 th	118	83	83
3 rd	206	146	146
2 nd	294	208	208
1 st	323	215	241

Level	Compression Brace Force $\beta \omega R_y F_y A_{sc}$ (kips)	Compression Brace x component (kips)	Compression Brace y component (kips)
4 th	135	96	96
3 rd	237	167	167
2 nd	338	239	239
1 st	372	248	277



Anchor-rod design

- $F_{nt} = \phi 0.75 F_u = 44.7ksi$
- $A_{required} = 626K / 44.7ksi = 14.0in^2$
- Use (6) 1^{3/4}" ϕ F1554 Gr 55 anchor rods
 - $A_{net} = 1.90in^2$
 - $\phi F_u A_{net} = 0.75(75ksi)1.90in^2 = 107K/rod$
 - 6 rods: $6 * 107K = 641K$ OK



Anchor-rod design

Table 14-2
Recommended Maximum Sizes for
Anchor-Rod Holes in Base Plates

Increase
for grade
55

- Use (6) 1³/₄" Grade 55 anchor rod F1554, S1

Anchor Rod Diameter, in.	Hole Diameter, in.	Min. Washer Size, in.	Min. Washer Thickness
1 ¹ / ₂	2 ⁵ / ₁₆	3 ¹ / ₂	1/2
1 ³ / ₄	2 ³ / ₄	4	3/4
2	3 ¹ / ₄	5	3/4
2 ¹ / ₂	3 ³ / ₄	5 ¹ / ₂	7/8

Notes: 1. Circular or square washers meeting the washer size are acceptable.
2. Clearance must be considered when choosing an appropriate anchor rod hole location, noting effects such as the position of the rod in the hole with respect to the column, weld size and other interferences.
3. When base plates are less than 1/4 in. thick, punching of holes may be an economical option. In this case, 3/4-in. anchor rods and 1¹/₁₆-in. diameter punched holes may be used with ASTM F844 (USS Standard) washers in place of fabricated plate washers.

Base-plate design

- Flexure under tension
 - $x = 3" + 0.1b_f = 3.10"$
 - Use $B=22"$
 - $T=626K/2=313K$
 - $M=313K(3.10")=970"K$
 - $t_p \geq 2.11 \sqrt{\frac{Tx}{BF_y}} = 1.98"$ Use 2" plate



AISC Design Guide 1 §3.2

94

Base-plate design

- Compression: assume 18"x18" bearing area
 - $965K/(18in \times 18in) = 2.98ksi$
 - $L = \frac{1}{2} [18" - 0.8b_f] = \frac{1}{2} [18" - 0.8(10.2")] = 4.92"$
 - $\lambda n' = \lambda \cdot \frac{\sqrt{db_f}}{4} = 1 \cdot \frac{\sqrt{(10.6)(10.2)}}{4} = 2.6"$
 - $M = WL^2/2 = 2.98ksi(18in)(4.92in)^2/2 = 649"K$
 - $t_p \geq 2.11 \sqrt{\frac{M}{BF_y}} = 1.79in$. Use 2" plate



AISC Design Guide 1 §3.1

95

Shear design

- $V_u = 248K$
- Provide direct transfer to concrete slab
 - Embedded structural steel angles (or other shapes)
 - A706 bar
 - etc.
 - Provide load path into foundation
- Combined tension shear and bending:
 - 3"Ø anchor rods



96

Gusset design coordination

- Communicate load path to gusset designer:
 - Tension
 - $H_2 = H_3 = 50\% H_u$
 - $V_1 = 100\% V_u$
 - $M_1 = 100\% eV_u$
 - Compression
 - $H_2 = H_3 = 50\% H_u$
 - No tension on gusset bottom edge
 - EOR must check column

97

Base Plate

Gr. 50 Plate 2"x22"x30"
 (6) 1 1/2" Gr. 55 Anchor rods with 3/4"x3 1/2"x3 1/2" plate washers at base plate and at bottom.
 De-bond rods from concrete.

98

There's always a solution in steel.

Improved performance

AMERICAN INSTITUTE OF STEEL CONSTRUCTION
 structural STEEL

Improved performance

- BRBF provide very good reliability against collapse
- Residual drift is not addressed in AISC 341
 - Residual drift can be reduced through the introduction of a modest restoring force
 - Add moment frames adjacent to braced frames
 - Act as robust collectors
 - Reduce overturning on braced-frame columns

100

Improved performance

- Supplemental moment frames
 - Design as OMF
 - Follow OMF connection detailing requirements
 - Do not utilize OMF in the analysis
 - Design BRBF for 100% of the force



Improved performance

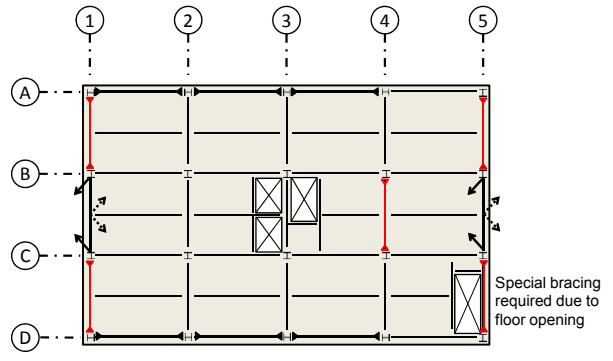

Completion of design

There's always a solution in steel.



Completion of design

- Braces
 - Indicate protected zone
 - Review manufacturer's design
 - Review testing information
- Connections
 - Indicate DCW
- Beam
 - Design lateral bracing
- Column
 - Design column splice



Completion of design

- Base plate
 - Provide load path for shear
 - Design concrete anchorage/force transfer to foundation
 - Design grade beam for ductile rotation
- Specifications
 - Specify weld toughness requirements
 - Specify Quality Assurance Plan



105

Summary

There's always a solution in steel.



Summary

- BRBF have a rigorous capacity design procedure
 - Design braces first
 - Compute maximum brace forces
 - Requires data from manufacturers
 - Design
 - Beams
 - Columns
 - Connections



107

Summary

- BRBF require coordination and partnership with manufacturers
 - Review assumptions
 - Load path
 - Design responsibilities
 - Review factors
 - β , ω
 - Review testing
 - Factors
 - Cover all project braces



108

There's always a solution in steel.

Course wrap-up



AMERICAN INSTITUTE OF STEEL CONSTRUCTION
structural STEEL

Course wrap-up

- Mild structural steel provides excellent ductility
- Proper proportioning and detailing of steel systems provides controlled inelastic behavior
- Ductile design permits economical buildings
 - Required strength is reduced
 - Large inelastic drifts can be accommodated



110

Course wrap-up

- Design example
 - Efficient design can result from
 - Early identification of governing design loads
 - Simplifying as appropriate so that analysis supports design decisions
 - Economical design can result from
 - Selecting the appropriate systems
 - Reducing the need for member reinforcement



111

There's always a solution in steel.

End of session 8

*And the end of the
Night-School course*



AMERICAN INSTITUTE OF STEEL CONSTRUCTION
structural STEEL

Additional resources



Engineering Journal
American Institute of Steel Construction

Effective Length Factors for Gusset Plate Buckling

MEMBER	NON-MEMBER
FREE	\$10.00

DOWNLOAD



NEHRP Seismic Design Technical Brief No. 11
 Seismic Design of Steel Buckling-Restrained Braced Frames
 A Guide for Practicing Engineers

2017 SEAC CONVENTION PROCEEDINGS

Design of Chevron Gusset Plates

Rafael Sabelli, Director of Seismic Design
Walter P Moore
San Francisco, California
Leigh Arber, Senior Engineer
American Institute of Steel Construction
Chicago, Illinois

Abstract

The "Chevron Effect" is a term used to describe local beam forces in the gusset region of a chevron (also termed inverted-V) braced frame. These local forces are typically missed by beam analysis methods that neglect connection dimensions. Recent publications have shown how to correctly analyze for these forces (Fortney & Thornton, AISC Engineering Journal, Vol. 52, 2015). This study adds design solutions for addressing high shears in the connection region, including reinforcement.



113

There's always a solution in steel.

Question time



Individual Webinar Registrants

CEU/PDH Certificates

Within 2 business days...

- You will receive an email on how to report attendance from: registration@aisc.org.
- Be on the lookout: Check your spam filter! Check your junk folder!
- Completely fill out online form. Don't forget to check the boxes next to each attendee's name!



Individual Webinar Registrants

CEU/PDH Certificates

Within 2 business days...

- New reporting site (URL will be provided in the forthcoming email).
- Username: Same as AISC website username.
- Password: Same as AISC website password.



8-Session Registrants

CEU/PDH Certificates

One certificate will be issued at the conclusion of all 8 sessions.



8-Session Registrants

CEU/PDH Certificates

One certificate will be issued at the conclusion of all 8 sessions.

Certificates will be issued the week of May 7, 2018.



8-Session Registrants

Final Exam

Issued: April 24, 2018
Due: May 7, 2018



8-Session Registrants

Access to the quiz: Information for accessing the quiz will be emailed to you by Wednesday. It will contain a link to access the quiz. EMAIL COMES FROM NIGHTSCHOOL@AISC.ORG

Quiz and Attendance records: Posted Tuesday mornings.
www.aisc.org/nightschool - click on Current Course Details.

Reasons for quiz:

- EEU – must take all quizzes and final to receive EEU
- CEUs/PDHS – If you watch a recorded session you must take quiz for CEUs/PDHS.
- REINFORCEMENT – Reinforce what you learned tonight. Get more out of the course.

NOTE: If you attend the live presentation, you do not have to take the quizzes to receive CEUs/PDHS.



8-Session Registrants

Access to the recording: Information for accessing the recording will be emailed to you by this Wednesday. The recording will be available for three weeks. For 8-session registrants only. EMAIL COMES FROM NIGHTSCHOOL@AISC.ORG.

CEUs/PDHS – If you watch a recorded session you must take AND PASS the quiz for CEUs/PDHS.



Night School Resources for 8-session package Registrants

Go to www.aisc.org and sign in.

The screenshot shows the MyAISC user interface. On the left, a sidebar menu lists options: Edit Profile, My Downloads, My Pending Quizzes, My Events, Order History, Course History, and Course Resources. The 'Course Resources' item is circled in red. The main content area has sections: 'MY PROFILE' with an 'EDIT PROFILE' button, 'MY PURCHASED DOWNLOADS' with a 'VIEW DOWNLOADS' button, and 'MY COURSE RESOURCES' with a 'VIEW RESOURCES' button. The 'MY COURSE RESOURCES' section and its button are also circled in red.

Thank You

Please give us your feedback!
Survey at conclusion of webinar.

There's always a solution in steel.

