



Thank you for joining our live webinar today.
We will begin shortly. Please standby.



Thank you.

Need Help?
Call ReadyTalk Support: 800.843.9166



Today's audio will be broadcast through the internet.



Alternatively, to hear the audio through the phone, dial
800-289-0459. Passcode: 316042



Today's live webinar will begin shortly.
Please standby.

As a reminder, all lines have been muted. Please type any
questions or comments through the Chat feature on the left
portion of your screen.

Today's audio will be broadcast through the internet.
Alternatively, to hear the audio through the phone, dial
800-289-0459. Passcode: 316042



*AISC is a Registered Provider with The American Institute of
Architects Continuing Education Systems (AIA/CES). Credit(s)
earned on completion of this program will be reported to AIA/CES
for AIA members. Certificates of Completion for both AIA members
and non-AIA members are available upon request.*

*This program is registered with AIA/CES for continuing professional
education. As such, it does not include content that may be
deemed or construed to be an approval or endorsement by the AIA
of any material of construction or any method or manner of
handling, using, distributing, or dealing in any material or product.*

*Questions related to specific materials, methods, and services will
be addressed at the conclusion of this presentation.*





Copyright Materials

This presentation is protected by US and International Copyright laws. Reproduction, distribution, display and use of the presentation without written permission of AISC is prohibited.

© The American Institute of Steel Construction 2018



Session Description

Session 7: Façade Attachments, Part 2 July 30, 2018

Many multi-story structural-steel-framed buildings support the facade's gravity and lateral loads from the spandrel beams or the slab edges. In this session, we will examine the pros and cons of connections to spandrel beams and slab edges along with methods for designing these elements for facade loads. The session will include a series of example problems that address issues of strength and stiffness.



Learning Objectives

- List the detailing options for supporting building facades at cantilever slabs.
- Explain the role of pour stops and bent plates in supporting slab edges and building facades.
- Identify the structural elements that can be added to the system to control the twist of spandrel beams supporting building facades.
- Describe two methods for calculating torsional stresses and rotations of spandrel beams by hand.



Behind the Facade: Guidance for Supporting Facades on Steel-Framed Buildings

Session 7: Façade Attachments, Part 2
July 30, 2018



Alec Zimmer, P.E.
Senior Project Manager
Simpson Gumpertz & Heger Inc.
Waltham, MA

There's always a solution in steel.



Syllabus for Night School Sessions

- **Session 1**
 - Fundamentals of Facades
 - Design Criteria
- Session 2
 - Design and Execution Responsibilities
- Session 3
 - Planning for Clearances
 - Thermal Bridging
- Session 4
 - Accommodating Tolerances

9

Syllabus for Night School Sessions

- Session 1
- **Session 2**
 - Traditional Masonry Cavity Walls
 - Panelized Façade Systems
 - Aluminum-Glass Curtain Walls
 - Sizing Joints for Vertical Movement
- Session 3
- Session 4

10



Syllabus for Night School Sessions

- Session 1
- Session 2
- **Session 3**
 - Slab Edges
 - Spandrel Beams
 - Cladding Supports Away from Floors
- Session 4

11

Slab Edge Conditions

Slab Edge Conditions





The slab edge detail is an important consideration when designing for façade attachments.

12

Slab Edge Conditions

Factors that Influence the Design

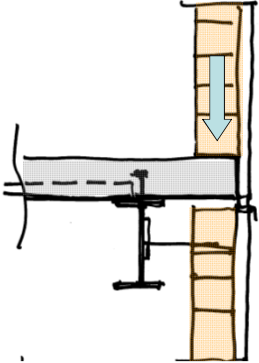
- Type, weight, and location of facade
- Amount of slab overhang
- Slab or deck capacity
- Application of facade loads
- Consistent conditions

13

Slab Edge Conditions

Two Fundamental Approaches

- The slab or deck cantilever acts as a beam with a cantilever end to support the facade load.
- The designer does not count on the slab or deck to support the facade loads.

Approach 1

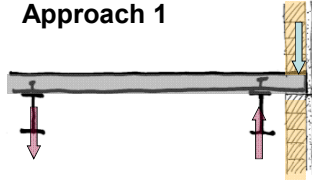

Approach 2

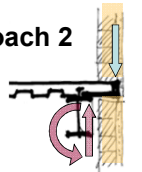





14

Slab Edge Conditions

Project Conditions Affecting Choice of Approach

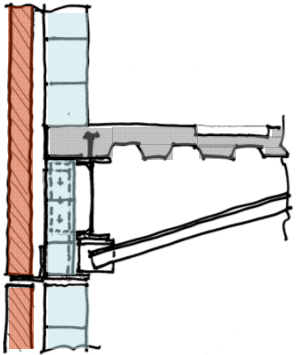
- Does the typical slab have the capacity?
- Concrete slab?
- Quality control concerns with concrete?
- Slab depressions or openings near the spandrel beam?
- Attachment details need thick plate?

15

Slab Edge Conditions

Approach 1: Slab Cantilever Resolves Eccentricity

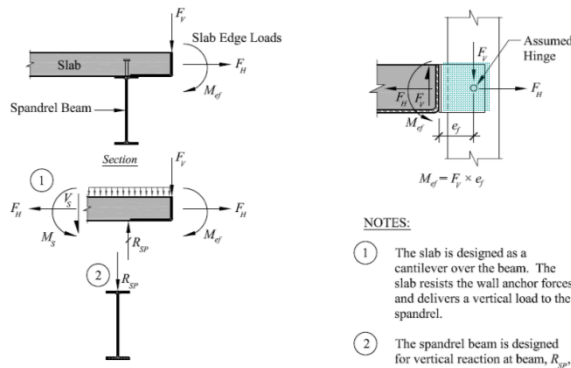

NOTES:

- 1 The slab is designed as a cantilever over the beam. The slab resists the wall anchor forces and delivers a vertical load to the spandrel.
- 2 The spandrel beam is designed for vertical reaction at beam, R_{sp} , no torsion.



16

Slab Edge Conditions

Design of Slab Overhang

Negative moment due to facade loads
 Positive moment due to interior loads on floor

17

Slab Edge Conditions

Design of Slab Overhang

Slab Reactions (3)
 Facade Load
 Pour Stop
 Spandrel Beam

Metal Deck Perpendicular to Spandrel

Slab Reactions (3)
 Facade Load
 Pour Stop
 Spandrel Beam

Metal Deck Parallel to Spandrel

NOTES:

- ① The full slab depth is effective when the deck is perpendicular to the spandrel. The effective width is reduced by the presence of the flutes in the deck.
- ② Only the slab depth above the deck is effective when the deck is parallel to the spandrel. The effective width, however, is not reduced.
- ③ The façade load is transferred directly to the slab. The light-gage metal pour stop is not effective as a means of façade attachment.

18

Slab Edge Conditions

Design of Slab Overhang

Loaded Area at Edge
 Slab Edge
 Spandrel Beam Below

Plan at Slab Edge

NOTES:

- ① Effective width at tip of flange at slab overhang.
- ② Effective width at critical section for slab back span. Note that if the deck is perpendicular to the spandrel, the effective width is reduced by the presence of the flutes in the deck. Use the sum of the rib widths within the effective strip.

19

Slab Edge Conditions

Design Aids in Design Guide

Table 5-4. Cantilevered Slab Flexural Strength, ϕM_n , kip-in. / ft
 Concrete Compressive Strength $f'_c = 3,000$ psi
 3-in. Composite Floor Deck Parallel to Spandrel Beam

Slab Reinforcement	Composite Floor Slab Total Thickness (in.)												
	Bars	in. ² /ft	5	5 1/2	6	6 1/4 ⁽⁶⁾	6 1/2	7	7 1/8 ⁽⁶⁾	7 1/2 ⁽⁶⁾	8	8 1/4 ⁽⁶⁾	8 1/2
#3@18 ⁽⁶⁾	0.07	2.92	4.89	6.86	7.8	8.83	10.8	11.5	12.8	14.7	15.7	16.7	16.7
#3@16 ⁽⁶⁾	0.08	3.28	5.52	7.76	8.9	10.0	12.2	13.1	14.5	16.7	17.8	19.0	19.0
#3@12	0.11	4.18	7.15	10.1	11.6	13.1	16.1	17.2	19.0	22.0	23.5	25.0	25.0
#4@18 ⁽⁶⁾	0.13	4.19	8.04	11.6	13.4	15.2	18.8	20.2	22.4	26.0	27.8	29.6	29.6

Table 5-8. Cantilevered Slab Flexural Strength, ϕM_n , kip-in. / ft
 Concrete Compressive Strength $f'_c = 3,000$ psi
 3-in. Composite Floor Deck Perpendicular to Spandrel Beam

Slab Reinforcement	Composite Floor Slab Total Thickness (in.)												
	Bars	in. ² /ft	5	5 1/2	6	6 1/4 ⁽⁷⁾	6 1/2	7	7 1/8 ⁽⁶⁾	7 1/2 ⁽⁶⁾	8	8 1/4 ⁽¹⁰⁾	8 1/2
#3@18 ⁽⁶⁾	0.07	14.5	16.5	18.5	19.5	20.5	22.4	23.2	24.4	26.4	27.4	28.4	28.4
#3@16 ⁽⁶⁾	0.08	16.4	18.6	20.8	22.0	23.1	25.3	26.2	27.6	29.8	30.9	32.0	32.0
#3@12	0.11	21.4	24.3	27.3	28.8	30.3	33.2	34.4	36.2	39.2	40.7	42.2	42.2
#4@18 ⁽⁶⁾	0.13	25.1	28.6	32.2	34.0	35.8	39.4	40.8	43.0	46.6	48.4	50.2	50.2

20

Slab Edge Conditions

Case Study: Closure Strips

Continuous cell closure strip reduces shear capacity of the slab

21

Slab Edge Conditions

Approach 2: Slab Cantilever Does Not Resolve Eccentricity

22

Slab Edge Conditions

(See previous slide)

NOTES:

- ① The steel edge member is designed to transfer the forces to spandrel. The moment and shear resistance of the slab is ignored. However, the slab or deck may be designed for in-plane horizontal forces.
- ② The spandrel is designed for vertical load and torsion. The torsion is resolved at columns, roll beams, or kickers.

NOTE:
 A kicker at the point of vertical load eliminates torsion in spandrel beam.

23

Slab Edge Conditions

Approach 2: Slab Cantilever Does Not Resolve Eccentricity

- Some strategies:
 - Rigid facade brackets help reduce eccentricity
 - Kickers
 - Roll beams
 - Torsion in spandrel

24

Slab Edge Conditions

Slab Edges with Light Gage Metal Pour Stops

NOTES:

- 1 Pour stop is designed for wet weight of concrete, concrete fluid pressure on vertical leg, and 20 psf live load.
- 2 Slab is designed for self weight and all superimposed loads.
- 3 Overhang is generally less than 12 inches.

25

Slab Edge Conditions

Use of Light Gage Metal Pour Stops at Slab Edge

- Inexpensive and simple to adjust and erect.
- Clear overhang less than 12 inches.
- Slab will have strength to support all superimposed loads.
- Façade attachment loads go directly into slab (or directly into spandrel) and not through the pour stop.
- Must consider support of pour stops at columns and corners.

26

Slab Edge Conditions

Design of Light Gage Metal Pour Stops

27

Slab Edge Conditions

SDI Pour Stop Selection Table

SLAB THICKNESS (inches)	OVERHANG (inches)												
	0	1	2	3	4	5	6	7	8	9	10	11	12
4.25	20	20	20	18	18	18	16	14	12	12	10	10	10
4.50	20	20	20	18	18	18	16	14	12	12	10	10	10
4.75	20	20	20	18	18	18	16	14	12	12	10	10	10
5.00	20	20	18	18	18	16	14	12	12	10	10	10	10
5.25	20	18	18	18	16	14	14	12	12	10	10	10	10
5.50	20	18	18	16	16	14	14	12	12	10	10	10	10
5.75	20	18	18	16	14	14	12	12	12	10	10	10	10
6.00	18	18	18	16	14	14	12	12	12	10	10	10	10
6.25	18	18	18	16	14	12	12	12	12	10	10	10	10
6.50	18	18	18	16	14	12	12	12	12	10	10	10	10
6.75	18	18	16	16	14	12	12	12	12	10	10	10	10
7.00	18	18	16	14	14	12	12	12	12	10	10	10	10
7.25	18	16	14	14	12	12	12	12	10	10	10	10	10
7.50	18	16	14	12	12	12	12	10	10	10	10	10	10
7.75	18	14	14	12	12	12	10	10	10	10	10	10	10
8.00	12	14	12	12	12	12	10	10	10	10	10	10	10
8.25	12	14	12	12	12	10	10	10	10	10	10	10	10
8.50	14	12	12	12	12	10	10	10	10	10	10	10	10
8.75	14	12	12	12	10	10	10	10	10	10	10	10	10
9.00	14	12	12	10	10	10	10	10	10	10	10	10	10
9.25	12	12	12	10	10	10	10	10	10	10	10	10	10
9.50	12	12	12	10	10	10	10	10	10	10	10	10	10
9.75	12	12	10	10	10	10	10	10	10	10	10	10	10
10.00	12	12	10	10	10	10	10	10	10	10	10	10	10
10.25	12	12	10	10	10	10	10	10	10	10	10	10	10
10.50	12	12	10	10	10	10	10	10	10	10	10	10	10
10.75	12	10	10	10	10	10	10	10	10	10	10	10	10
11.00	12	10	10	10	10	10	10	10	10	10	10	10	10
11.25	12	10	10	10	10	10	10	10	10	10	10	10	10
11.50	10	10	10	10	10	10	10	10	10	10	10	10	10
11.75	10	10	10	10	10	10	10	10	10	10	10	10	10
12.00	10	10	10	10	10	10	10	10	10	10	10	10	10

28

Slab Edge Conditions

Case Study: Flat Plate Slab Edge

29

Slab Edge Conditions

Slab Edges with Structural Steel Bent Plates

- Case 1
 - Simply a pour stop with large overhang.
 - Slab takes superimposed loads and resolves eccentricity, Approach 1.

30

Slab Edge Conditions

Bent Plate Case 1: Pour Stop Only

31

Slab Edge Conditions

Design Aids in Design Guide 22

Table 5-10. Minimum Thickness of Bent Plate, in.
 Used as a Pour Stop for Normal-Weight Concrete

Slab Thickness, in.	Slab Overhang, in.																	
	4	5	6	7	8	9	10	11	12	13	14	15	16	17	18			
4	3/8	3/8	3/8	3/8	3/8	3/8	3/8	3/8	3/8	3/8	3/8	3/8	3/8	3/8	3/8			
4 1/4	3/8	3/8	3/8	3/8	3/8	3/8	3/8	3/8	3/8	3/8	3/8	3/8	3/8	3/8	3/8			
4 1/2	3/8	3/8	3/8	3/8	3/8	3/8	3/8	3/8	3/8	3/8	3/8	3/8	3/8	3/8	3/8			
4 3/4	3/8	3/8	3/8	3/8	3/8	3/8	3/8	3/8	3/8	3/8	3/8	3/8	3/8	3/8	3/8			
5	3/8	3/8	3/8	3/8	3/8	3/8	3/8	3/8	3/8	3/8	3/8	3/8	3/8	3/8	3/8			
5 1/4	3/8	3/8	3/8	3/8	3/8	3/8	3/8	3/8	3/8	3/8	3/8	3/8	3/8	3/8	3/8			
5 1/2	3/8	3/8	3/8	3/8	3/8	3/8	3/8	3/8	3/8	3/8	3/8	3/8	3/8	3/8	3/8			
5 3/4	3/8	3/8	3/8	3/8	3/8	3/8	3/8	3/8	3/8	3/8	3/8	3/8	3/8	3/8	3/8			
6	3/8	3/8	3/8	3/8	3/8	3/8	3/8	3/8	3/8	3/8	3/8	3/8	3/8	3/8	3/8			
6 1/4	3/8	3/8	3/8	3/8	3/8	3/8	3/8	3/8	3/8	3/8	3/8	3/8	3/8	3/8	3/8			
6 1/2	3/8	3/8	3/8	3/8	3/8	3/8	3/8	3/8	3/8	3/8	3/8	3/8	3/8	3/8	3/8			
6 3/4	3/8	3/8	3/8	3/8	3/8	3/8	3/8	3/8	3/8	3/8	3/8	3/8	3/8	3/8	3/8			
7	3/8	3/8	3/8	3/8	3/8	3/8	3/8	3/8	3/8	3/8	3/8	3/8	3/8	3/8	3/8			

32

Slab Edge Conditions

Slab Edges with Structural Steel Bent Plates

- Case 2
 - A pour stop plus means to attach facade.
 - Slab takes superimposed loads and resolves eccentricity, Approach 1

33

Slab Edge Conditions

Bent Plate Case 2 – Pour Stop Plus Means to Attach Façade Elements

NOTES:

- Design bent steel plate as pour stop. Commonly $\frac{1}{8}$ inch min. and $\frac{1}{2}$ inch max. thickness. Consider steel plate over light gage metal pour stop for large overhangs and/or embedment plates.
- Example of embedment plate for facade attachment. Field weld or otherwise field anchor to steel closure plate. Design to transfer facade attachment loads to slab.
- Shop weld pour stop to spandrel beam if tolerances are accommodated in the facade attachment details; otherwise field weld.
- Overlap as necessary for weld design.
- Maintain minimum clearance for headed studs.
- Design slab to cantilever over spandrel and support loads from facade attachment.

34

Slab Edge Conditions

Design Aids in Design Guide 22

Table 5-12. Headed Stud Tensile Strength, ϕN_t , kips
 4,000 psi Normal-Weight Concrete Slab Edges

Headed Stud Diameter, in.	Embedment Depth, in.	Total Slab Height, h_s , in.									
		4	4½	5	5½	6	6½	7	7½	7¾	8¼
½	6	2.66	3.03	3.40	3.78	4.16	4.56	4.96	5.16	5.30	5.99
	8	3.01	3.41	3.82	4.24	4.66	5.09	5.30	5.74	5.30	6.64
	10	3.32	3.75	4.20	4.65	5.11	5.30	5.30	6.27	5.30	7.23
¾	6	2.66	3.03	3.40	3.78	4.16	4.56	4.96	5.16	5.37	5.99
	8	3.01	3.41	3.82	4.24	4.66	5.09	5.52	5.74	5.96	6.64
	10	3.32	3.75	4.20	4.65	5.11	5.57	6.04	6.27	6.51	7.23
1	6	2.66	3.03	3.40	3.78	4.16	4.56	4.96	5.16	5.37	5.99
	8	3.01	3.41	3.82	4.24	4.66	5.09	5.52	5.74	5.96	6.64
	10	3.32	3.75	4.20	4.65	5.11	5.57	6.04	6.27	6.51	7.23

Design Guide 22 includes separate tables for shear capacities. Design Guide 22 does not consider the interaction of shear and tension.

35

Slab Edge Conditions

Slab Edges with Structural Steel Bent Plates

- Case 3
 - No slab to count on or ignored by the designer – Approach 2.

36

Slab Edge Conditions

Bent Plate Case 3 – Ignoring Slab Except for In-Plane Forces from Façade

NOTES:

- When only the slab in-plane strength is considered, the steel plate (or assembly) must deliver the vertical load F_v to the spandrel beam.
- The steel plate and headed stud (or deformed bar dowel) transfers the horizontal façade force F_h to the slab.
- The slab reinforcement is designed for the tension from the horizontal façade force plus the horizontal force from the couple resulting from the kicker.
- The spandrel beam is designed for the vertical loads and reactions, plus torsion between the kickers if the façade loads are applied between kickers.

37

Slab Edge Conditions

Transfer of In-Plane Forces to the Slab

NOTES:

- Develop slab reinforcement with 180° hook within embedment of headed stud.
- Deformed bar dowel threaded into bar coupler welded to bent plate. Lap with slab reinforcement.

38

Slab Edge Conditions

Bent Plate Fabrication and Attachment

39

Slab Edge Conditions

Bent Plate Fabrication and Attachment

(See previous slides)

NOTES:

- Indicate design overlap with minimum and maximum for tolerance and adjustment. Design should consider minimum flange widths for minimum overlap, minimum deck bearing, and room for headed studs.
- Provide nominal amount of weld to resist incidental uplift during erection.
- Provide weld as required to resist loads on plate.
- Field adjustment is usually modest due to geometry of flange width and bolt hole edge distances.

40

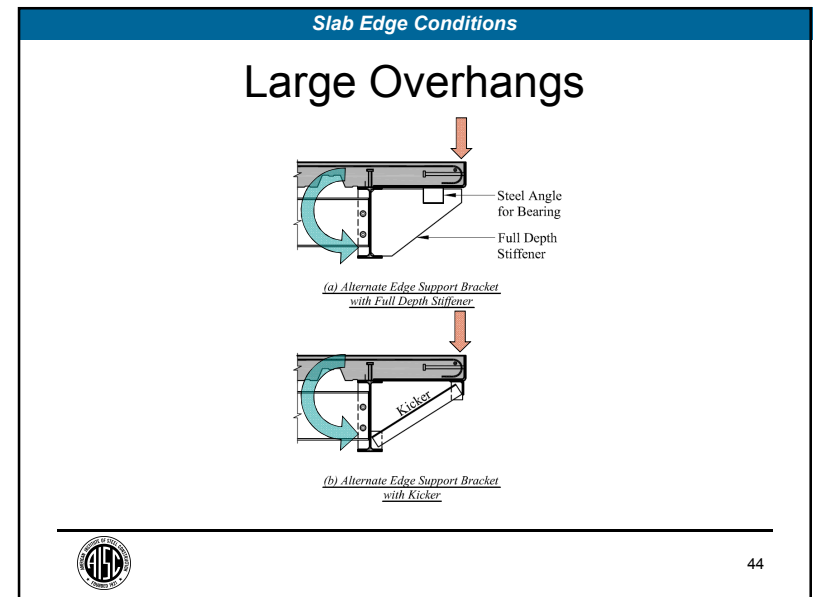
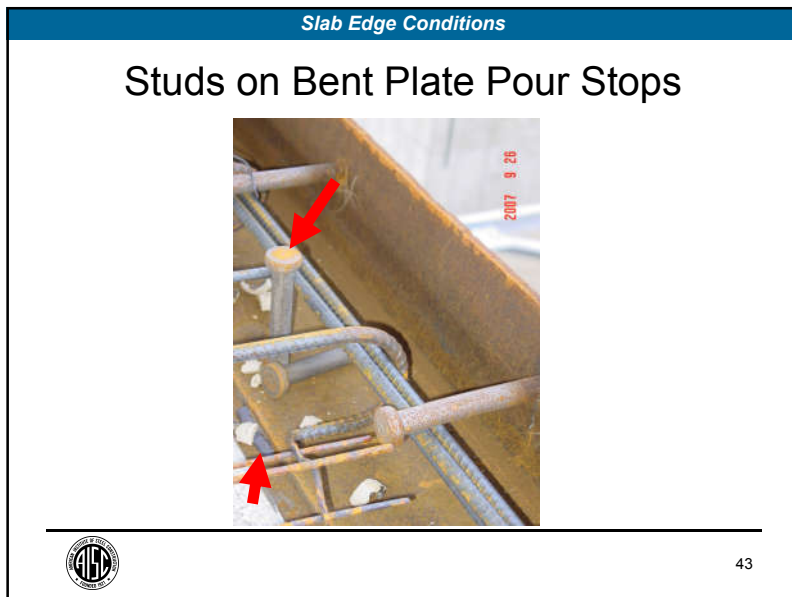
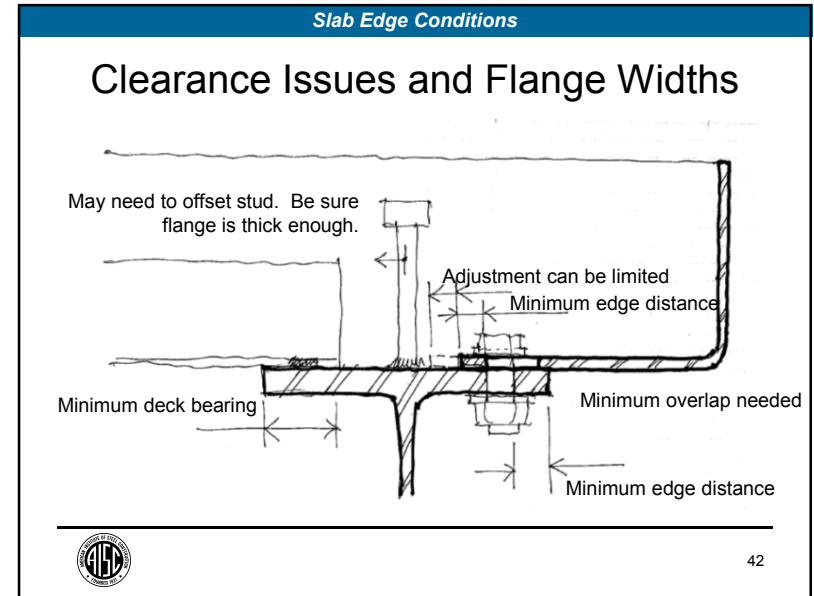
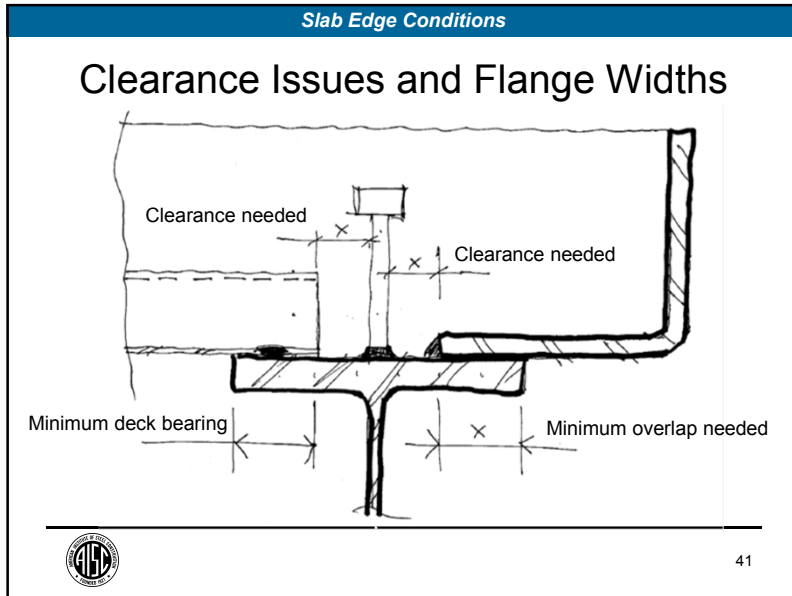

Slab Edge Conditions

Design Guide 22 Chapter 5 Examples

- **Example 5.1** – Metal Pour Stop Selection
- **Example 5.2** – Concrete Slab Overhanging a Spandrel Beam
- **Example 5.3** – Bent Plate as a Pour Stop
- **Example 5.4** – Slab Edge With Bent Plate as Pour Stop and Façade Anchorage Plate
- **Example 5.5** – Slab Edge, Bent Plate Supports Façade Loads
- **Example 5.6** – Slab Edge, Welded Bar Coupler Transfers Façade Loads



45

Slab Edge Conditions

Example 5.6: Bent Plate Design

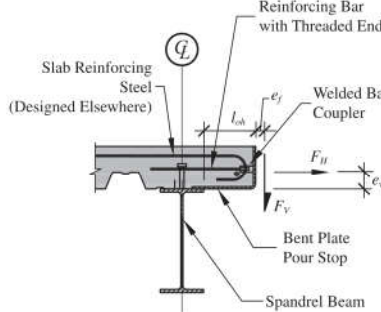

Bent plate pour stop supporting a façade with the slab flexural and shear capacity ignored, except for resisting out-of-plane forces. Excerpted from Design Guide 22. See Design Guide for complete, detailed example.



46

Slab Edge Conditions

Example 5.6

Determine the required plate thickness and verify that the vertical deflection of the bent plate does not exceed 3/16 in. for Condition C:

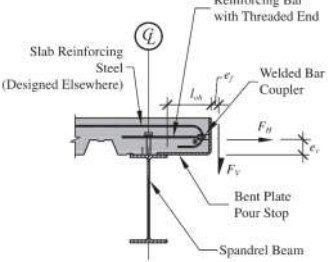

The vertical load, $F_V = 1.8$ kip, is applied at $e_V = 5$ in. from the face of the bent plate. The horizontal load, $F_H = 1.8$ kips, is applied at eccentricity, $e_H = 3\frac{1}{2}$ in., above the bottom of the bent plate. The bent plate cantilever beyond the beam flange is $l_{oh} = 9$ in.

Also determine the required weld size between the plate and the beam flange.

In all cases, design the bent plate to resist all of the façade loads without relying on the concrete slab flexural strength. Use ASTM A36 plate material.



47

Slab Edge Conditions

Example 5.6

Given:

For this example, assume that the controlling strength load combination is ~~$1.4D$ (D for deflection) for Conditions A and B, and $1.2D + 1.6W$ ($D + W$ for deflection) for Condition C.~~ F_V is the cladding dead load and F_H is the wind load. The bent plate pour stop is adequate to resist the wet weight of concrete. The spandrel beam is adequate to resist the torsional loads from the bent plate. Once cured, the concrete slab is adequate to support its own weight and superimposed floor loads.

The architect has set the slab edge such that the distance from the slab edge to the tip of the spandrel beam flange, $l_{oh} = 9$ in. The total slab height, $h_s = 7\frac{1}{2}$ in. Thus, the length of the vertical leg of the bent plate, $l_{vert} = 7\frac{1}{2}$ in. The overlap of the bent plate to the weld on the beam flange, $s_{weld} = 2\frac{1}{2}$ in.



48

Slab Edge Conditions

Example 5.6

The horizontal force, F_H , acting on the vertical leg of the bent plate is transferred directly to the slab by the welded bar coupler and threaded reinforcing bar. A moment, M_{ef} , exists due to the horizontal eccentricity, e_f , between the vertical load, F_V , and the face of the plate.

$$M_{ef} = F_V e_f$$

$$= 1.8 \text{ kips}(5 \text{ in.})$$

$$= 9.00 \text{ kip-in.}$$

49

Slab Edge Conditions

Example 5.6

With the welded bar coupler located at the mid-depth of the slab, the moment arm for this couple, $e_v = 3\frac{3}{4}$ in. Thus, the bent plate can be designed for the flexure due to F_V applied at its tip only.

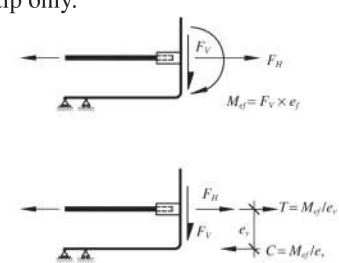



Fig. 5-34. Analysis model for plate design.



50



Slab Edge Conditions

Example 5.6

For the strength load combination $1.4D$, the required flexural strength is,

$$M_u = 1.4F_V l_{oh}$$

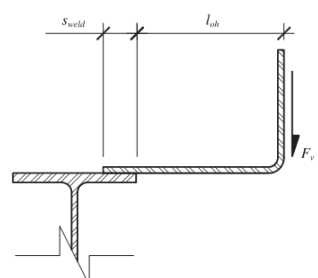
$$= 1.4(1.8 \text{ kips})(9 \text{ in.})$$

$$= 22.7 \text{ kip-in.}$$



51

Slab Edge Conditions

Example 5.6

Try a $\frac{7}{16}$ -in. bent plate thickness. The effective width, b_{eff} , of the bent plate that resists the effects of F_V is determined assuming that the load spreads at a 45° angle in both directions (see Figure 5-28). Thus,

$$b_{eff} = 2 \tan(45^\circ) l_{oh}$$

$$= 2 \tan(45^\circ)(9 \text{ in.})$$

$$= 18.0 \text{ in.}$$

$$\phi_b M_n = \phi_b F_y Z$$

$$= 0.90(36 \text{ ksi})(0.861 \text{ in.}^3)$$

$$= 27.9 \text{ kip-in.} \geq M_u \quad \mathbf{o.k.}$$

$Z = \frac{1}{4} b_{eff} t^2$

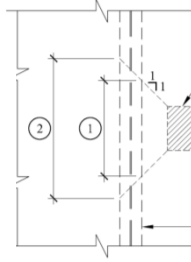

Plan at Slab Edge

The $1.6F_y S$ limit need not be checked because $Z/S = 1.5$ for a rectangular plate in bending.



52

Slab Edge Conditions

Example 5.6

For deflection, using AISC Manual Table 3-23, case 26,

$$\Delta_V = \frac{F_V l_{oh}^2}{3EI} (l_{oh} + s_{weld})$$

$$= \frac{1.8 \text{ kips}(9 \text{ in.})^2}{3(29,000 \text{ ksi})(0.126 \text{ in.}^4)} (9 \text{ in.} + 2\frac{1}{2} \text{ in.})$$

$$= 0.153 \text{ in.} \leq \frac{3}{16} \text{ in.} \text{ o.k.}$$

$I = \frac{1}{12} b_{eff} t^3$

Use a $\frac{3}{16}$ -in. bent plate thickness.



53

Slab Edge Conditions

Example 5.6

Try a $\frac{3}{16}$ -in. fillet weld with $F_{EXX} = 70$ ksi between the bent plate pour stop and the spandrel beam flange. As developed previously in Example 5.3, the required length of fillet weld per ft of width is,

$$l_{min} = \frac{M_u}{1.392 \text{ kip/in.}(1.5) D s_{weld}}$$

$$= \frac{22.7 \text{ kip-in.}}{1.392 \text{ kip/in.}(1.5)(3)(2\frac{1}{2} \text{ in.})}$$

$$= 1.45 \text{ in.}$$

The minimum permissible fillet weld length is $1\frac{1}{2}$ in. per Specification Section J2.2b.

Use intermittent $\frac{3}{16}$ -in. fillet welds, $1\frac{1}{2}$ -in. long at 12 in. on center.



54

Slab Edge Conditions

Example 5.6

Comments:

Using a welded bar coupler and threaded reinforcing bar to resist the out-of-plane forces can reduce the required thickness of the bent plate pour stop, even in instances where the slab is not designed to resist the flexure as a cantilever. As illustrated in Figure 5-34, the welded bar coupler and threaded reinforcing bar must be designed for the effects of the tension forces. If the applicable load combination were $1.2D + 1.6W$, the corresponding required strength is,

$$T_u + F_{uH} = \frac{1.2F_V e_f}{e_v} + 1.6F_H$$

$$= \frac{1.2(1.8 \text{ kips})(5 \text{ in.})}{3\frac{3}{4} \text{ in.}} + 1.6(1.8 \text{ kips})$$

$$= 5.76 \text{ kips}$$

Headed studs can also be used for this purpose, as illustrated in Example 5.4.

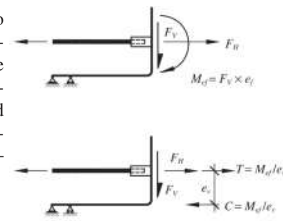

Fig. 5-34. Analysis model for plate design.



55

Slab Edge Conditions

Example 5.6

As illustrated in Figure 5-34, there is also a compression component equal to,

$$C_u = \frac{1.2F_V e_f}{e_v}$$

$$= \frac{1.2(1.8 \text{ kips})(5 \text{ in.})}{3\frac{3}{4} \text{ in.}}$$

$$= 2.88 \text{ kips}$$

It is assumed that this force is resisted by bearing of the bent plate on the concrete. When this is not the case, or the concrete compressive strength is not adequate, the bent plate thickness can be selected based upon interaction of the moment and compressive force.

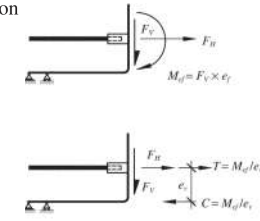

Analysis model for plate design.



56

Design of Steel Spandrel Beams

Design of Steel Spandrel Beams



The design of the spandrel beam is more than selecting a wide flange shape that meets flexural strength and stiffness criteria.



57

Design of Steel Spandrel Beams

General Design Considerations

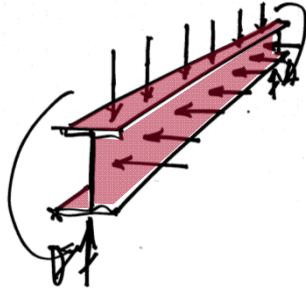

- Flexural Strength
 - Composite or Noncomposite?
 - Part of a Moment Frame?
 - Any weak axis bending?



58

Design of Steel Spandrel Beams

General Design Considerations

- Flexural Stiffness
 - Precomposite DL
 - Post-composite DL
 - Façade load
 - Superimposed DL
 - Superimposed LL
 - Floor vibrations
 - Creep, long-term
 - Weak axis loads

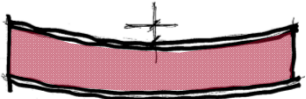

59

Design of Steel Spandrel Beams

General Design Considerations

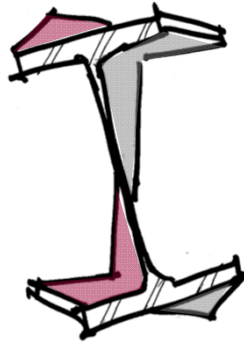

- Torsion
 - Accounted for in strength design?
 - Resolved at columns?
 - Kickers?
 - Roll beams?
 - Rotation and projected translations?



60

Design of Steel Spandrel Beams

General Design Considerations

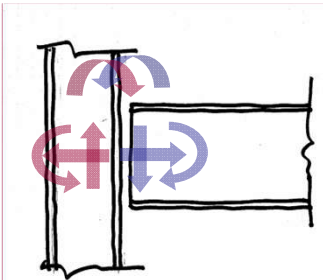

- Connection to Columns
 - Simple shear?
 - Special copes, non standard?
 - Horizontal forces?
 - Torsional forces?



61

Design of Steel Spandrel Beams

General Design Considerations

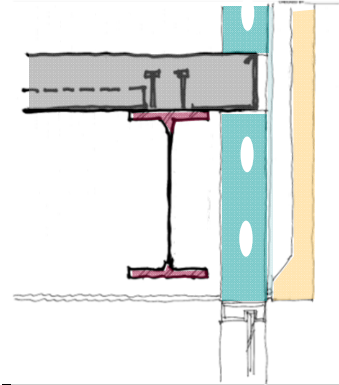

- Spandrel dimensions
 - Depth
 - Flange width
 - Flange thickness
 - Project consistency



62

Design of Steel Spandrel Beams

General Design Considerations

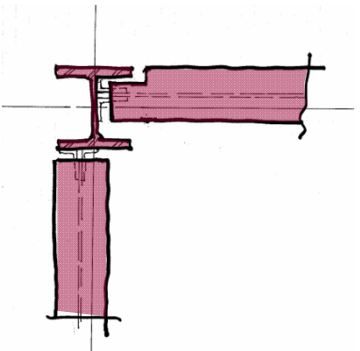

- Centerline location
 - Column connections?
 - Minimize facade eccentricities?
 - Clearances for adjustments?



63

Design of Steel Spandrel Beams

General Design Considerations

- Fabrication and erection
 - Accounted for?
 - Weight versus complexity?
 - Weight versus erection efficiency?

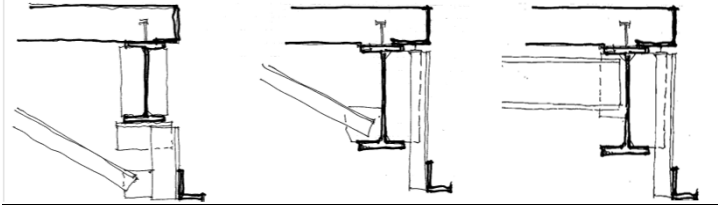

64

Design of Steel Spandrel Beams

Design for Vertical Loads

- Stiffness usually controls, but:
 - Check combined stresses
 - Local stresses
 - Flanges
 - Web

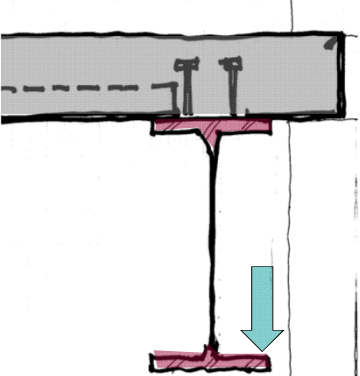

65

Design of Steel Spandrel Beams

Deflection and Movement Limits

- Curvature
 - $L/360$, $L/400$, $L/600$, etc.
- Absolute magnitude for joints
- Must consider rotation as well as vertical deformations

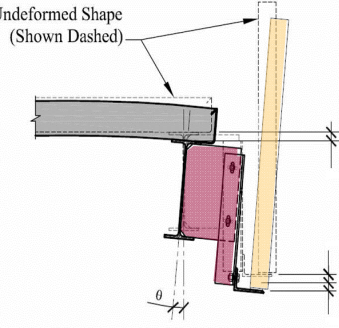

66

Design of Steel Spandrel Beams

Sequence of Loading for Serviceability

- When do the deflections occur relative to the construction of the façade?
 - Which loads close joints in the back-up?
 - Which loads close joints in the façade?

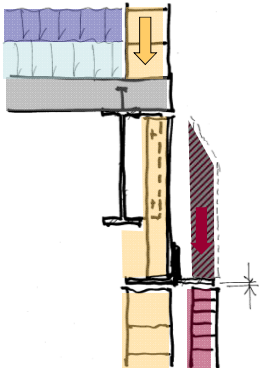

67

Design of Steel Spandrel Beams

Case Study: Deflection Design

- Framing Parameters:
 - 30 ft span
 - SIDL: 10 psf
 - LL: 100 psf
 - Story height: 12 ft
 - Spandrel trib. width: 5.5 ft
 - 6-1/4 in. LWC on 3 in. deck
 - Deck parallel to beam
 - Ignore torsion...for now...
- Example Walls:
 - BV + CMU Backup
 - BV + SS Backup
 - 6" PC Wall Panel
 - Aluminum Curtain Wall

68

Design of Steel Spandrel Beams

Case Study: Deflection Design

**Table 6-1. Example Composite Spandrel Beam Deflections
Brick Veneer Cladding 8 in. CMU Back-Up (Grouted 32 in. o.c.)**

	Deflection Restriction		
	no δ restriction	$\delta_{NTD} = L/240$ $\delta_{LL} = L/360$	$\delta_{LL+SIDL} = 3/16$ in.
Required spandrel size	W16x26	W16x31	W21x62
Pre-composite deflection, in.	0.606	0.494	0.154
Deflection due to back-up, in.	0.424	0.356	0.165
Deflection due to brick, in.	0.339	0.284	0.132
Deflection due to SIDL, in.	0.0389	0.0326	0.015
Deflection due to LL, in.	0.389	0.326	0.151
Camber, in.	none	none	none
Net Total Deflection, in.	1.798	1.494	0.617
$\delta_{LL+SIDL}$, in.	0.429	0.359	0.166
$M_r / \phi_b M_n$	0.934	0.774	0.421

69

Design of Steel Spandrel Beams

Case Study: Deflection Design

**Table 6-2. Example Composite Spandrel Beam Deflections
Brick Veneer Cladding with 6 in. Steel Stud Back-Up (16-in. Spacing)**

	Deflection Restriction		
	no δ restriction	$\delta_{NTD} = L/240$ $\delta_{LL} = L/360$	$\delta_{LL+SIDL} = 3/16$ in.
Required spandrel size	W12x19	W16x26	W21x62
Pre-composite deflection, in.	1.369	0.606	0.154
Deflection due to back-up, in.	0.113	0.081	0.0279
Deflection due to brick, in.	0.501	0.359	0.132
Deflection due to SIDL, in.	0.0574	0.041	0.0151
Deflection due to LL, in.	0.574	0.411	0.151
Camber, in.	none	none	none
Net Total Deflection, in.	2.614	1.499	0.482
$\delta_{LL+SIDL}$, in.	1.132	0.811	0.166
$M_r / \phi_b M_n$	0.937	0.754	0.327

70

Design of Steel Spandrel Beams

Case Study: Deflection Design

**Table 6-3. Example Composite Spandrel Beam Deflections
6 in. Precast Concrete Panel Cladding**

	Deflection Restriction		
	no δ restriction	$\delta_{NTD} = L/240$ $\delta_{LL} = L/360$	$\delta_{LL+SIDL} = 3/8$ in.
Required spandrel size	W14x22	W16x26	W18x40
Pre-composite deflection, in.	0.903	0.606	0.312
Deflection due to precast, in.	0.735	0.533	0.457
Deflection due to SIDL, in.	0.0449	0.0326	0.0297
Deflection due to LL, in.	0.449	0.326	0.297
Camber, in.	none	none	none
Net Total Deflection, in.	2.133	1.497	1.076
$\delta_{LL+SIDL}$, in.	1.229	0.892	0.307
$M_r / \phi_b M_n$	0.930	0.736	0.621

71

Design of Steel Spandrel Beams

Case Study: Deflection Design

**Table 6-4. Example Composite Spandrel Beam Deflections
Aluminum Curtain Wall Cladding System**

	Deflection Restriction		
	no δ restriction	$\delta_{NTD} = L/240$ $\delta_{LL} = L/360$	$\delta_{LL+SIDL+CW} = 3/4$ in.
Required spandrel size	W12x14	W16x26	W16x26
Pre-composite deflection, in.	1.973	0.606	0.606
Deflection due to curtain wall, in.	0.243	0.151	0.151
Deflection due to SIDL, in.	0.0744	0.0462	0.0462
Deflection due to LL, in.	0.744	0.462	0.462
Camber, in.	1.25	none	none
Net Total Deflection, in.	1.786	1.266	1.266
$\delta_{LL+SIDL+CW}$, in.	1.061	0.659	0.659
$M_r / \phi_b M_n$	0.930	0.633	0.633

72



Design of Steel Spandrel Beams

Designing for Torsion

Soft Joint Aligns with Window Heads

(a) Brick veneer and block facade system

(b) Facade forces impose torsion on spandrel beam

73

Design of Steel Spandrel Beams

Designing for Torsion

PLAN VIEW

74

Design of Steel Spandrel Beams

Kickers to Mitigate Torsion

Kickers eliminate torsion

Plan View

Section View

75

Design of Steel Spandrel Beams

Kickers to Mitigate Torsion

Kickers reduce torsion – torsion in spandrel between kickers.

Plan View

76

Design of Steel Spandrel Beams

Kickers to Mitigate Torsion

NOTES:

- 1 The steel edge member is designed to transfer the forces to the spandrel. The slab is neglected.
- 2 The spandrel beam is designed for the vertical reactions and torsion between kicker locations.
- 3 Kicker reaction results in both horizontal and vertical load to bottom flange of spandrel.
- 4 The force couple at the top and bottom flange resolves accumulated torsion from spandrel. The top flange of the spandrel must be restrained by the deck/slab or a supplemental member.
- 5 The kicker applies a vertical and horizontal force to an interior beam and/or slab.

77

Design of Steel Spandrel Beams

Roll Beams to Mitigate Torsion

Roll beam reduces torsion.
 Torsion in spandrel between roll beam and columns.

Plan View

Section View

"Moment" connection

78

Design of Steel Spandrel Beams

Roll Beams to Mitigate Torsion

79

Design of Steel Spandrel Beams

(See previous slide)

NOTES:

- 1 The steel edge member is designed to transfer the forces to the spandrel. The slab is neglected, except for horizontal forces.
- 2 The spandrel beam is designed for the vertical reactions and torsion between roll beams. The roll beams restrain twist of the spandrel at intermittent locations.
- 3 A full-depth stiffener or other connection is designed for moment and resulting vertical reactions. The reactions may include floor loads if the roll beam is also a floor beam.
- 4 The moment in the roll beam is determined as the accumulated torsion from the spandrel.
- 5 The moment applied to the end of the roll beam is resolved by vertical shears at each end.

80

Design of Steel Spandrel Beams

Designing for Torsion

- Detailed guidance on torsional stresses and rotations of bare steel wide-flange shapes.
- Rotation about center of shape.
- Considers warping normal stresses and torsional shear stresses.

81

Design of Steel Spandrel Beams

Flexural Analogy Method

(a) Flexural Analogy for Calculating Idealized Rotation Ignoring Slab Restraint

82

Design of Steel Spandrel Beams

Center of Rotation

(a) Idealized Torsion-Ignoring Slab

(b) Actual Torsion-Slab Flexure Restraining Motion

(c) Idealized Torsion-Ignoring Slab Flexure but Including In-Plane Restraint

83

Design of Steel Spandrel Beams

Slab Only Restrains Translation

Slab changes center of rotation and reduces the amount of rotation by forcing the center of rotation up.

84

Design of Steel Spandrel Beams

Effects of Rotation at Slab

θ_{FA}
 Δ_{hrb}
 Δ_{vrb}

85

Design of Steel Spandrel Beams

Modified AISC Design Guide 9 Method

Use DG #9 Method to get rotation and then assume rotation occurs at top of beam at slab.

86

Design of Steel Spandrel Beams

Modified Flexural Analogy

$F = T/h$
 F
 h
 Δ_F

(a) *Flexural Analogy for Calculating Idealized Rotation Ignoring Slab Restraint*

(b) *Flexural Analogy for Calculating Rotation with Top Flange Braced Laterally - No Rotational Restraint by Slab or Deck*

87

Design of Steel Spandrel Beams

Appendix A Study

- Three models
 - FEM
 - Modified DG #9
 - Modified Flex. Analogy
- Two spans
 - 10 ft
 - 30 ft
- Two load shapes
 - Concentrated
 - Uniform

88

Design of Steel Spandrel Beams

Appendix A Study

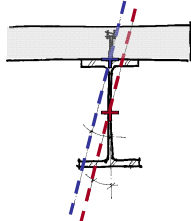

Modified DG #9 Method

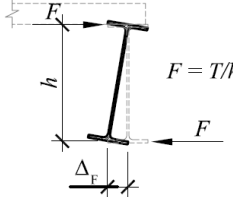

$F = T/h$

Modified Flexural Analogy Method

89

Design of Steel Spandrel Beams

Appendix A Study

Table A-1. Top Flange Rotation for 10-ft Span with Distributed Twist

Beam	Rotation (rad.)			Ratio		
	Finite Element Model (FEM)	Modified Design Guide Method (MDGM)	Modified Flexural Analogy Method (MFAM)	MDGM/ FEM	MFAM/ FEM	MDGM/ MFAM
W14x30	0.417	0.807	0.477	1.93	1.14	1.69
W14x43	0.178	0.349	0.209	1.97	1.18	1.67
W18x40	0.242	0.468	0.291	1.93	1.20	1.61
W18x60	0.0879	0.175	0.107	1.99	1.22	1.63
W24x62	0.0791	0.158	0.0923	2.00	1.17	1.71
W24x117	0.00865	0.020	0.0101	2.31	1.17	1.97

On shorter spans, the MFAM more closely matches FEM results.

90

Design of Steel Spandrel Beams

Appendix A Study

Table A-2. Top Flange Rotation for 10-ft Span with Concentrated Mid-Span Twist

Beam	Rotation (rad.)			Ratio		
	Finite Element Model (FEM)	Modified Design Guide Method (MDGM)	Modified Flexural Analogy Method (MFAM)	MDGM/ FEM	MFAM/ FEM	MDGM/ MFAM
W14x30	0.333	0.648	0.382	1.95	1.15	1.70
W14x43	0.141	0.281	0.168	1.99	1.19	1.68
W18x40	0.193	0.377	0.233	1.96	1.21	1.62
W18x60	0.0699	0.140	0.0858	2.01	1.23	1.64
W24x62	0.0629	0.127	0.0738	2.02	1.17	1.72
W24x117	0.00684	0.016	0.00811	2.34	1.19	1.97

On shorter spans, the MFAM more closely matches FEM results.

91

Design of Steel Spandrel Beams

Appendix A Study

Table A-3. Top Flange Rotation for 30-ft Span with Distributed Twist

Beam	Rotation (rad.)			Ratio		
	Finite Element Model (FEM)	Modified Design Guide Method (MDGM)	Modified Flexural Analogy Method (MFAM)	MDGM/ FEM	MFAM/ FEM	MDGM/ MFAM
W14x30	20.1	25.4	42.4	1.26	2.11	0.599
W14x43	8.37	9.83	17.2	1.17	2.06	0.571
W18x40	10.7	12.9	24.3	1.21	2.27	0.531
W18x60	3.90	4.81	8.72	1.23	2.24	0.551
W24x62	4.11	5.27	7.50	1.28	1.82	0.703
W24x117	0.603	0.961	0.821	1.59	1.36	1.17

On longer spans, the MFAM is excessively conservative.

92

Design of Steel Spandrel Beams

Appendix A Study

Table A-4. Top Flange Rotation for 30-ft Span with Concentrated Mid-Span Twist

Beam	Rotation (rad.)			Ratio		
	Finite Element Model (FEM)	Modified Design Guide Method (MDGM)	Modified Flexural Analogy Method (MFAM)	MDGM/FEM	MFAM/FEM	MDGM/MFAM
W14x30	5.43	6.98	10.4	1.29	1.91	0.674
W14x43	2.25	2.71	4.53	1.21	2.01	0.599
W18x40	2.88	3.56	6.29	1.24	2.18	0.566
W18x60	1.05	1.33	2.32	1.27	2.21	0.574
W24x62	1.11	1.44	1.99	1.31	1.80	0.724
W24x117	0.161	0.259	0.219	1.61	1.36	1.18

On longer spans, the MFAM is excessively conservative.



93

Design of Steel Spandrel Beams

Appendix A Study - Conclusion

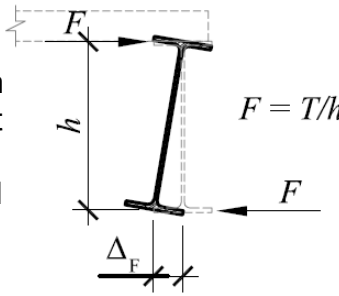
- For most practical cases where torsional spans need to be kept short (on the range of 10 ft) to limit deflections the Modified Flexural Analogy Method better reflects actual conditions and is easier to implement.





94

Design of Steel Spandrel Beams

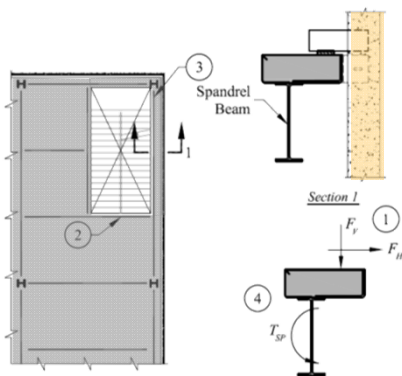
Other Conditions with Torsion



Framing Part-Plan

95

Design of Steel Spandrel Beams

Other Options for Increasing Rotational Resistance

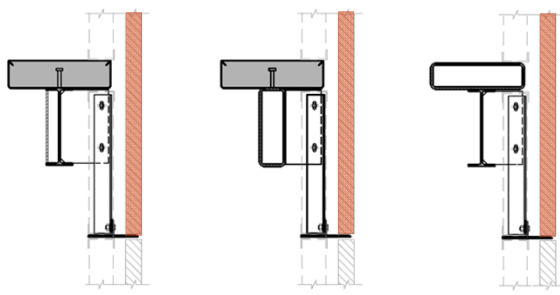

(Note: Sheathing and Insulation Not Shown for Clarity, Typ.)

(a) Wide-Flange Beam with Cover Plate

(b) HSS

(c) Wide-Flange Beam/HSS Combination

96

Design of Steel Spandrel Beams

Design Guide 22 Chapter 6 Examples

- **Example 6.1** - Roof Spandrel Beam with Eccentric Curtain Wall Load
- **Example 6.2** - Roof Spandrel Beam with Eccentric Curtain Wall Load – Torsion Restrained with Roll Beams
- **Example 6.3** - Roof Spandrel Beam with Eccentric Curtain Wall Load – Torsion Avoided with HSS and Roll Beams
- **Example 6.4** - Roof Spandrel Beam with Eccentric Curtain Wall – Torsion on Spandrel Avoided by Kickers
- **Example 6.5** - Floor Spandrel Beam with Eccentric Precast Panel Loads
- **Example 6.6** - Floor Spandrel Beam with Eccentric Precast Panel Loads at Floor Opening

 97

Design of Steel Spandrel Beams

Example 6.1: Roof Spandrel Beam

Excerpts from Design Guide. See Design Guide 22 for complete, detailed example.

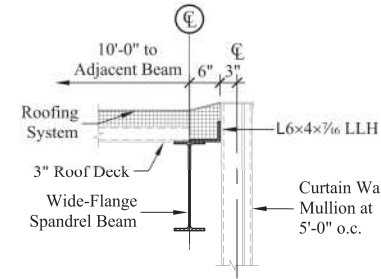

Fig. 6-7. Section of roof spandrel beam with eccentric curtain wall load.

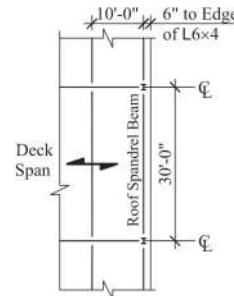



Fig. 6-8. Roof plan at spandrel beam.

 98

Design of Steel Spandrel Beams

Example 6.1

Design Assumptions:

1. The beam can be assumed to be flexurally pinned and torsionally restrained at the supporting columns.
2. The roof deck braces the compression flange of the beam against lateral torsional buckling. The roof deck also resists the lateral wind load.
3. Assume the following load combinations control:
 Strength: $1.2D + 1.6S + 0.8W$
 Deflection: $D + S + W$
4. Acceptable deflection limit is 0.90 in.

 99

Design of Steel Spandrel Beams

Example 6.1

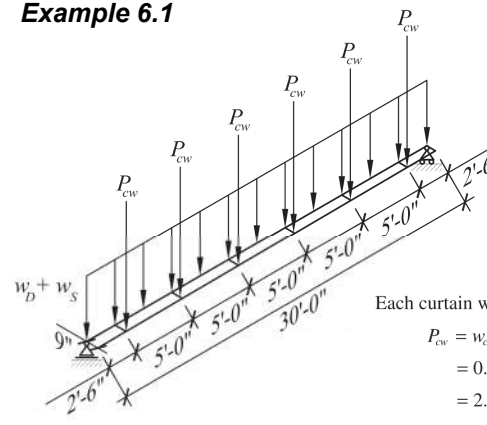

Note that wind loads are omitted for clarity.

Each curtain wall point load on the beam is,

$$P_{cw} = w_{curt} h_c s_c$$

$$= 0.015 \text{ kip/ft}^2 (28 \text{ ft})(5 \text{ ft})$$

$$= 2.10 \text{ kips}$$

Fig. 6-9. Loads on roof spandrel beam.

 100

Design of Steel Spandrel Beams

Example 6.1

Try W18×35, ASTM A992

Step 1: Design Beam Neglecting Torsion.

A. Design the beam for strength

Demand-to-capacity ratio

$$\frac{M_u}{\phi_b M_n} = \frac{102 \text{ kip-ft}}{249 \text{ kip-ft}} = 0.410 \leq 1.0 \quad \text{o.k.}$$

Demand-to-capacity ratio

$$\frac{V_u}{\phi_v V_n} = \frac{13.7 \text{ kips}}{159 \text{ kips}} = 0.0862 \leq 1.0 \quad \text{o.k.}$$



101

Design of Steel Spandrel Beams

Example 6.1

The total deflection includes both the deflection of the L6×4×7/16 edge angle and the deflection of the spandrel beam.

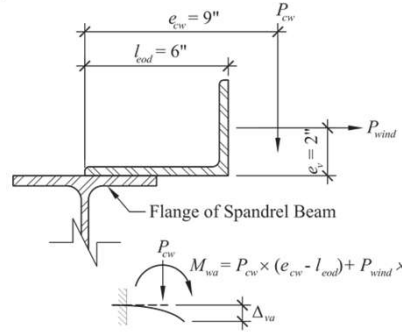



Fig. 6-10. Loads on curtain wall support angle.



102

Design of Steel Spandrel Beams

Example 6.1

Because the tip of the angle leg is at the beam flange centerline, the distance from the heel of the angle to the tip of the beam flange, $l_{oh} = 3$ in. Thus,

$$b_{eff} = 2 \tan(45^\circ)(l_{oh} + e_v) + b_{cw}$$

$$= 2 \tan(45^\circ)(3 \text{ in.} + 2 \text{ in.}) + 2 \text{ in.}$$

$$= 12.0 \text{ in.}$$

b_{eff} is effective width
 e_v is vertical eccentricity
 l_{oh} is angle cantilever

The edge angle moment of inertia is,

$$I = \frac{b_{eff} t^3}{12}$$

$$= \frac{12.0 \text{ in.} \left(\frac{7}{16} \text{ in.}\right)^3}{12}$$

$$= 0.0837 \text{ in.}^4$$



103

Design of Steel Spandrel Beams

Example 6.1

For the angle deflection, each point load on the edge angle is.

$$P_{wind} = p_w s_c \left(\frac{h}{2}\right)$$

$$= 0.030 \text{ kips/ft}^2 (5 \text{ ft}) \left(\frac{14 \text{ ft}}{2}\right)$$

$$= 1.05 \text{ kips}$$

p_w is wind pressure
 s_c is curtain wall spacing
 h is story height

The wind point load acts at the center of the vertical angle leg; thus, $e_v = 2$ in. The moment at the base of the vertical leg of the edge angle due to the wind point load is,

$$M_{wa} = P_{cw}(e_{cw} - l_{eod}) - P_{wind} e_v$$

$$= 2.10 \text{ kips} (9 \text{ in.} - 6 \text{ in.}) - 1.05 \text{ kip} (2 \text{ in.})$$

$$= 8.4 \text{ kip-in.}$$



104

Design of Steel Spandrel Beams

Example 6.1

The total vertical deflection of the angle tip (using AISC Manual Table 3-23, case 22, and an additional term to account for the effect of moment M_{wa}), is

$$\begin{aligned}\Delta_{va} &= \frac{P_{cw}l_{oh}^3}{3EI} + \frac{M_{wa}l_{oh}^2}{2EI} \\ &= \frac{2.10 \text{ kips} (3 \text{ in.})^3}{3(29,000 \text{ ksi})(0.0837 \text{ in.}^4)} \\ &\quad + \frac{8.4 \text{ kip-in} (3 \text{ in.})^2}{2(29,000 \text{ ksi})(0.0837 \text{ in.}^4)} \\ &= 0.0234 \text{ in.}\end{aligned}$$

Note that this neglects torsional effects on the spandrel.



105

Design of Steel Spandrel Beams

Example 6.1

For the spandrel beam deflection, the uniform service load is,

$$\begin{aligned}w &= w_D + w_S \\ &= 0.118 \text{ kip/ft} + 0.165 \text{ kip/ft} \\ &= 0.283 \text{ kip/ft}\end{aligned}$$

The corresponding deflection at midspan is,

$$\begin{aligned}\Delta_w &= \frac{5wL^4}{384EI_x} \\ &= \frac{5(0.283 \text{ kip/ft})(30 \text{ ft})^4 (12 \text{ in./ft})^3}{384(29,000 \text{ ksi})(510 \text{ in.}^4)} \\ &= 0.349 \text{ in.}\end{aligned}$$



106

Design of Steel Spandrel Beams

Example 6.1

Using AISC Manual Table 3-23, case 9, the midspan deflections due to the curtain wall point loads along the beam span are as follows. For the pair of loads at 2½ ft from the beam end ($a_1 = 2½ \text{ ft}$),

$$\begin{aligned}\Delta_{p1} &= \frac{P_{cw}a_1}{24EI_x} (3L^2 - 4a_1^2) \\ &= \frac{2.10 \text{ kips} (2½ \text{ ft})(12 \text{ in./ft})^3}{24(29,000 \text{ ksi})(510 \text{ in.}^4)} [3(30 \text{ ft})^2 - 4(2½ \text{ ft})^2] \\ &= 0.0684 \text{ in.}\end{aligned}$$

Repeat at 7½ ft ($\Delta = 0.190 \text{ in}$) and 12½ ft ($\Delta = 0.265 \text{ in}$)

Total Deflection = 0.0234 + 0.349 + 0.0684 + 0.190 + 0.265
= 0.896 < 0.9 inches which was given as the acceptable total deflection at mid-span

Note that this neglects torsional effects on the spandrel.



107

Design of Steel Spandrel Beams

Example 6.1

For Condition B with a W21x50 spandrel beam, the torsional analysis method presented in AISC Design Guide No. 9, *Torsional Analysis of Structural Steel Members* (Seaburg and Carter, 1997), will be used.

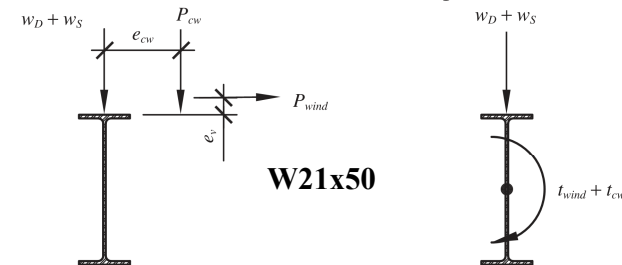

Fig. 6-11. Vertical and torsional loads on spandrel beam.



108

Design of Steel Spandrel Beams

Example 6.1

Using AISC Design Guide No. 9 Equation 4-16a, the interaction of combined normal stresses assuming the predominant limit state is yielding is,

$$\frac{M_u}{\phi_b F_y S_x} + \frac{\sigma_{wsu}}{0.9 F_y} = \frac{104 \text{ kip-ft}}{354 \text{ kip-ft}} + \frac{24.8 \text{ ksi}}{0.9(50 \text{ ksi})}$$

$$= 0.845 \leq 1.0 \quad \text{o.k.}$$

σ_{wsu} is warping normal stress (See DG9)

The interaction of pure torsion shear stress and direct shear is,

$$\frac{V_u}{\phi_v V_n} + \frac{\tau_t}{0.9(0.6 F_y)} = \frac{13.9 \text{ kips}}{237 \text{ kips}} + \frac{13.6 \text{ ksi}}{0.9(0.6)(50 \text{ ksi})}$$

$$= 0.562 \leq 1.0 \quad \text{o.k.}$$

τ_t is torsional shear stress (See DG9)

 109

Design of Steel Spandrel Beams

Example 6.1

Check Deflection at Mid-Span Flexural Deformation of W21x50
Vertical deflection = 0.473 in. (see example)

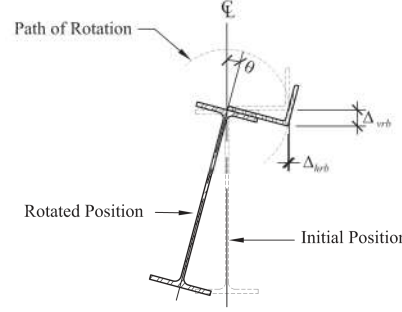



Fig. 6-12. Rigid body rotation about center of top flange.

 110

Design of Steel Spandrel Beams

Example 6.1

For the rotational components of the deflection calculations,

$$t = t_{cw} + t_{wind}$$

$$= 0.315 \text{ kip-ft/ft} + 0.0350 \text{ kip-ft/ft}$$

$$= 0.350 \text{ kin-ft/ft}$$

t_{cw} is torsion due to curtain wall
 t_{wind} is torsion due to wind

The rotation of the beam at midspan is based on the service level torsion,

$$\theta = 0.97 \text{ rad.} \left(\frac{t}{GJ} \right) 2a^2$$

$$= 0.97 \text{ rad.} \frac{(0.350 \text{ kip-ft/ft})}{(11,200 \text{ ksi})(1.14 \text{ in.}^4)} (2)(76.4 \text{ in.})^2$$

$$= 0.310 \text{ rad. (or } 17.8^\circ)$$

Refer to DG9, Appendix B, Case 4 for this calculation

The heel of the angle will deflect vertically by,

$$\Delta_{vrb} = l_{wd} \sin(17.8^\circ)$$

$$= (6.00 \text{ in.}) \sin(17.8^\circ)$$

$$= 1.83 \text{ in.}$$

Total vertical deflection of the beam is,
 $A_{total} = 0.473 \text{ in.} + 1.83 \text{ in.} = 2.30 \text{ in.}$

 111

Design of Steel Spandrel Beams

Example 6.1

This total vertical deflection substantially exceeds the deflection limit, primarily due to the torsional effects. In fact, the torsional effects alone for this beam exceed the stated deflection limit for the curtain wall system.

Thus, even a spandrel beam as heavy as a W21x50 has substantial torsional rotations. In the following examples, a system that uses roll beams to reduce the torsion on the spandrel beam will be designed.

 112

Design of Steel Spandrel Beams

Example 6.1

Modified Flexural Analogy Method

The weak-axis moment of inertia of the bottom half of the W21x50 beam is,

$$I_{y,FA} = \frac{I_y}{2} = \frac{24.9 \text{ in.}^4}{2} = 12.5 \text{ in.}^4$$

The corresponding deflection of the bottom flange is,

$$\Delta_{M,FA} = \frac{5w_{FA}L^4}{384EI_{y,FA}} = \frac{5(0.202 \text{ kip/ft})(30 \text{ ft})^4 (12 \text{ in./ft})^3}{384(29,000 \text{ ksi})(12.5 \text{ in.}^4)} = 10.2 \text{ in.}$$

Because the beam is forced to rotate about its top flange, the full beam depth can be used when calculating the angle of rotation, which is,

$$\theta_{FA} = \sin^{-1} \left(\frac{\Delta_{M,FA}}{d} \right) = \sin^{-1} \left(\frac{10.2 \text{ in.}}{20.8 \text{ in.}} \right) = 29.4^\circ$$

The equivalent uniform load applied laterally to the bottom flange to generate the torsional moment is,

$$w_{FA} = \frac{t}{d} = \frac{0.350 \text{ kip-ft/ft} (12 \text{ in./ft})}{20.8 \text{ in.}} = 0.202 \text{ kip/ft}$$

MFAM is excessively conservative for longer spans

113

Design of Steel Spandrel Beams

Example 6.2: Roof Spandrel Beam with Roll Beams

Excerpts from Design Guide. See Design Guide 22 for complete, detailed example.

114

Design of Steel Spandrel Beams

Example 6.2

Fig. 6-17. Loads on and reactions due to roll beam.

115

Design of Steel Spandrel Beams

Example 6.2

The rotation of the spandrel beam at midspan (between roll beams) is,

$$\theta = \frac{2F_T t a^2}{GJ} = \frac{2(0.037 \text{ rad.})(0.350 \text{ kip-ft/ft})(67.8 \text{ in.})^2}{(11,200 \text{ ksi})(0.810 \text{ in.}^4)} = 0.0131 \text{ rad. (or } 0.751^\circ)$$

$F_T = \text{Torsional rotation function from DG9, Appendix B, Case 4}$

Using AISC Design Guide No. 9 Equation 4-16a, the interaction of combined normal stresses assuming the predominant limit state is yielding is,

$$\frac{M_u}{\phi_b M_n} + \frac{\sigma_{wst}}{0.9F_y} = \frac{109 \text{ kip-ft}}{257 \text{ kip-ft}} + \frac{8.10 \text{ ksi}}{0.9(50 \text{ ksi})} = 0.604 \leq 1.0 \text{ o.k.}$$

116

Design of Steel Spandrel Beams

Example 6.2

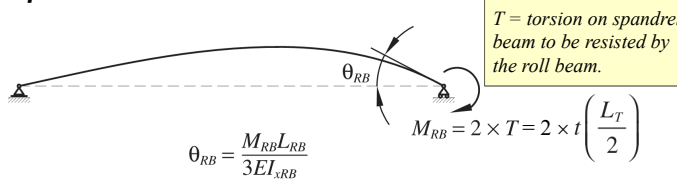

$$\theta_{RB} = \frac{M_{RB}L_{RB}}{3EI_{xRB}}$$

$$M_{RB} = 2 \times T = 2 \times t \left(\frac{L_T}{2} \right)$$

Fig. 6-18. Rotation of roll beam.

The rotation of the roll beam (see Figure 6-18) is,

$$\theta_{RB} = \frac{2TL_{RB}}{3EI_{xRB}} = \frac{2(1.75 \text{ kip-ft})(10 \text{ ft})(12 \text{ in./ft})^2}{3(29,000 \text{ ksi})(53.8 \text{ in.}^4)}$$

$$= 0.00108 \text{ rad (or } 0.0617^\circ)$$



117

Design of Steel Spandrel Beams

Example 6.2

The rotation of spandrel beam at midspan including the rotation contribution from the end of the roll beams is,

$$\theta_{total} = \theta + \theta_{RB}$$

$$= 0.751^\circ + 0.0617^\circ$$

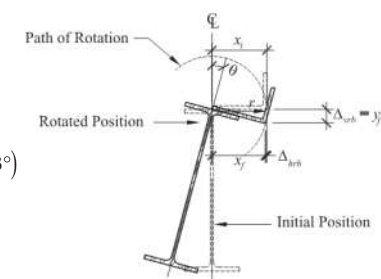
$$= 0.813^\circ$$

$$y_f = r \sin(\theta)$$

$$= (6.00 \text{ in.}) \sin(-0.813^\circ)$$

$$= -0.0851 \text{ in.}$$



118

Design of Steel Spandrel Beams

Example 6.2

The total vertical movement at the curtain wall attachment point (the sum of the flexural and rotational deflections) is,

$$\Delta_v = \Delta_f + \Delta_{vrb}$$

$$= 0.770 + 0.0851$$

$$= 0.855 \text{ in.} \leq 0.90 \text{ in.} \quad \mathbf{o.k.}$$

Note that Δ_v is comprised of flexural deformations due to the uniform load on the beam, the point loads from the curtain wall attachments and the roll beam reactions on the spandrel beam



119

Design of Steel Spandrel Beams

Example 6.2

Modified Flexural Analogy

Moment of inertia of bottom flange

$$I_{y_FA} = \frac{I_y}{2}$$

$$I_{y_FA} = 9.55 \text{ in}^4$$

Equivalent force to apply to bottom flange.

$$w_{FA} = \frac{t}{d}$$

$$w_{FA} = 235 \frac{\text{lb}}{\text{ft}}$$

Deflection of bottom flange

$$\Delta_{bf\ FA} = \frac{5w_{FA}L_T^4}{384E_{y\ FA}}$$

$$= \frac{5(0.235)(10)^4(1728)}{384(29,000)(9.55)} = 0.191 \text{ in.}$$



120

Design of Steel Spandrel Beams

Example 6.2

Because the beam is forced to rotate about its top flange the full beam depth can be used when calculating θ .

Equivalent rotation about the top flange using flexural analogy

$$\theta_{FA} = \tan^{-1} \left(\frac{\Delta_{bf FA}}{d} \right) = \tan^{-1} \left(\frac{0.191 \text{ in.}}{17.9 \text{ in.}} \right) = 0.610^\circ$$



In this case the rotation predicted by the flexural analogy is approximately 75-percent of the rotation from the design guide method. The actual rotation of the beam, as determined by finite element analysis, is approximately two thirds of the rotation predicted by the Design Guide 9 method and 84-percent of that predicted by the flexural analogy. This illustrates that for shorter spans, the flexural analogy is not only easier to calculate, but provides a more realistic rotation than the Design Guide 9 method.



121

Supporting Facades Away from Floor Levels

Supporting Facades Away from Floor Levels

At atrium and lobby spaces, it is frequently necessary to provide intermediate gravity and lateral load support for cladding system





122

Supporting Facades Away from Floor Levels

Design Criteria

- For curtain wall, typically limit deflections to:
 - L/360
 - 3/4 in. max
- Frequently architecturally exposed (AESS)
- May need hangers to support gravity loads





123

Supporting Facades Away from Floor Levels

Case Study: Curtain Wall Transition at Lobby Space

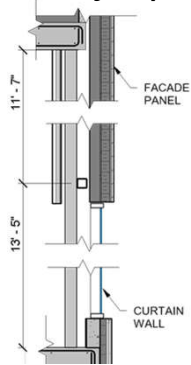

Section View

Problem:
A building has a panelized façade system. A double height space has curtain wall from the ground floor up to mid-height of the space and the façade panel extends down from the floor above. Typically, the façade panels are self supporting but the specialty engineer for the façade system indicates that at this location structural steel is required for the façade to laterally support the top of the curtain wall and the bottom of the panels.

Design the structural steel required to support the façade and curtain wall attachment. Deflection at the top of the curtain wall must be limited to 3/4" to avoid damaging the glass. Deflection of the façade panel does not govern.



124

Supporting Facades Away from Floor Levels

Case Study: Curtain Wall Transition at Lobby Space

Elevation View



125

There's always a solution in steel.

Question time



Individual Webinar Registrants

CEU/PDH Certificates

Within 2 business days...

- You will receive an email on how to report attendance from: registration@aisc.org.
- Be on the lookout: Check your spam filter! Check your junk folder!
- Completely fill out online form. Don't forget to check the boxes next to each attendee's name!



Individual Webinar Registrants

CEU/PDH Certificates

Within 2 business days...

- New reporting site (URL will be provided in the forthcoming email).
- Username: Same as AISC website username.
- Password: Same as AISC website password.



8-Session and 4-Session Registrants

CEU/PDH Certificates

One certificate will be issued at the conclusion of the full Night School course.



8-Session and 4-Session Registrants

Access to the quiz: Information for accessing the quiz will be emailed to you by Wednesday. It will contain a link to access the quiz. EMAIL COMES FROM NIGHTSCHOOL@AISC.ORG

Quiz and Attendance records: Posted Tuesday mornings.
www.aisc.org/nightschool - click on Current Course Details.

Reasons for quiz:

- EEU – must take all quizzes and final to receive EEU (**8-Session registrants only**)
- CEUs/PDHS – If you watch a recorded session you must take quiz for CEUs/PDHS.
- REINFORCEMENT – Reinforce what you learned tonight. Get more out of the course.

NOTE: If you attend the live presentation, you do not have to take the quizzes to receive CEUs/PDHS.



8-Session and 4-Session Registrants

Access to the recording: Information for accessing the recording will be emailed to you by this Wednesday. The recording will be available for three weeks. For package registrants only. EMAIL COMES FROM NIGHTSCHOOL@AISC.ORG.

CEUs/PDHS – If you watch a recorded session you must take AND PASS the quiz for CEUs/PDHS.

(Note that 4-Session registrants will not have access to the first four sessions)



8-Session and 4-Session Registrants

Find all your handouts, quizzes and quiz scores, recording access, and attendance information all in one place!



8-Session and 4-Session Registrants

Go to www.aisc.org and sign in.

The screenshot shows the AISC website homepage with a navigation menu at the top: EDUCATION, PUBLICATIONS, NASCC: THE STEEL CONFERENCE, SAFETY, STEEL SOLUTIONS CENTER, AWARDS AND COMPETITIONS, and RESEARCH LIBRARY. Below the navigation is a large banner with the AISC logo and the text "AISC". Underneath the banner is a "Login" section with the instruction "If you're an existing customer, please enter your username and password." There are two input fields: "USERNAME" and "PASSWORD". To the right of the login form is a "DON'T HAVE AN ACCOUNT?" section with the text "My AISC allows you to access Engineering Journal articles and Design Guides you have downloaded from the bookstore." and a "REGISTER NOW" button. At the bottom left of the login form is a "Remember Me" checkbox.

8-Session and 4-Session Registrants

Go to www.aisc.org and sign in.

The screenshot shows the "MyAISC" user profile page. On the left, there is a sidebar menu with options: "IN THIS SECTION", "Edit Profile", "My Downloads", "My Pending Quizzes", "My Events", "Order History", "Course History", and "Course Resources" (circled in red). The main content area has a "MY PROFILE" section with an "EDIT PROFILE" button. Below that is a "MY PURCHASED DOWNLOADS" section with a "VIEW DOWNLOADS" button. At the bottom, there is a "MY COURSE RESOURCES" section (circled in red) with the text "View online resources for Night School and Live Webinar package registrations." and a "VIEW RESOURCES" button.

8-Session and 4-Session Registrants

The screenshot shows the "Course Resources" page on the AISC website. The navigation menu at the top includes: EDUCATION, PUBLICATIONS, NASCC: THE STEEL CONFERENCE, SAFETY, STEEL SOLUTIONS CENTER, AWARDS AND COMPETITIONS, and TECHNICAL RESOURCES. Below the navigation is a banner with the AISC logo and the text "AISC". Underneath the banner is a breadcrumb trail: "AISC > MyAISC > COURSE RESOURCES". The main content area is titled "Course Resources" and contains a table with two columns: "Event" and "Start Date".

Event	Start Date
NS 13 8-Session Package-Night School 13 - Design of Industrial Buildings	1/30/2017 7:00:00 PM
NS 14 8-Session Package-Night School 14 - Fundamentals of Stability	6/5/2017 7:00:00 PM

8-Session and 4-Session Registrants

The screenshot shows the "Night School 13: Design of Industrial Buildings" page on the AISC website. The navigation menu at the top includes: EDUCATION, PUBLICATIONS, NASCC: THE STEEL CONFERENCE, SAFETY, STEEL SOLUTIONS CENTER, AWARDS AND COMPETITIONS, and RESEARCH LIBRARY. Below the navigation is a banner with the AISC logo and the text "AISC". Underneath the banner is a breadcrumb trail: "AISC > MyAISC > NIGHT SCHOOL RESOURCES > NS13 8-SESSION PACKAGE RESOURCES". The main content area is titled "Night School 13: Design of Industrial Buildings" and contains a section for "8-SESSION PACKAGE RESOURCES" with a table.

Event	Date	Handouts	Video	Quiz	Attendance
NS13 - Design Criteria	1/30/2017 7:00:00 PM	Handouts	Video	Pass Score: 80	Pending
NS13 - Economic Considerations	2/6/2017 7:00:00 PM	Handouts	Available 02/08/2017 5pm EST	Available 02/08/2017 5pm EST	Pending
NS13 - Lateral Load Systems and Details	2/13/2017 7:00:00 PM	Handouts	Available 02/15/2017 5pm EST	Available 02/15/2017 5pm EST	Pending
NS13 - Preliminary Design Procedures	2/27/2017 7:00:00 PM	Handouts	Available 03/01/2017 5pm EST	Available 03/01/2017 5pm EST	Pending
NS13 - Crane Girder Design and Frame Analysis	3/6/2017 7:00:00 PM	Handouts	Available 03/08/2017 5pm EST	Available 03/08/2017 5pm EST	Pending
NS13 - Frame Member and Connector Design	3/13/2017 7:00:00 PM	Handouts	Available 03/15/2017 5pm EST	Available 03/15/2017 5pm EST	Pending
NS13 - Transfer Crane Girder & Longitudinal Bog Bracing Dn	3/27/2017 7:00:00 PM	Handouts	Available 03/29/2017 5pm EST	Available 03/29/2017 5pm EST	Pending
NS13 - Building Envelope and Bracing Design	4/3/2017 7:00:00 PM	Handouts	Available 04/05/2017 5pm EST	Available 04/05/2017 5pm EST	Pending
NS13 - Final Exam	4/10/2017 7:00:00 PM	Handouts	Available 04/12/2017 5pm EST	Available 04/12/2017 5pm EST	Pending

8-Session and 4-Session Registrants

- Weekly “quiz and recording” email.
- Weekly updates of the master Quiz and Attendance record found at www.aisc.org/nightschool. Scroll down to Quiz and Attendance records.
 - Updated on Tuesday mornings.



8-Session and 4-Session Registrants

- Webinar connection information:
 - Found in your registration confirmation/receipt.
 - Reminder email sent out Monday mornings.
- Link to handouts also found here.



Thank You

Please give us your feedback!
Survey at conclusion of webinar.

There's always a solution in steel.

