

**AISC**  
**Night School**

Thank you for joining our live webinar today.  
We will begin shortly. Please standby.

Thank you.  
Need Help?  
Call ReadyTalk Support: 800.843.9166

**Steel Construction** | From the Mill to Topping Out



**Smarter.  
Stronger.  
Steel.**



Today's audio will be broadcast through the internet.

Alternatively, to hear the audio through the phone, dial 866-519-2796. Passcode: 387037





Today's live webinar will begin shortly.  
Please standby.

As a reminder, all lines have been muted. Please type any questions or comments through the Chat feature on the left portion of your screen.

Today's audio will be broadcast through the internet. Alternatively, to hear the audio through the phone, dial 866-519-2796. Passcode: 387037



*AISC is a Registered Provider with The American Institute of Architects Continuing Education Systems (AIA/CES). Credit(s) earned on completion of this program will be reported to AIA/CES for AIA members. Certificates of Completion for both AIA members and non-AIA members are available upon request.*

*This program is registered with AIA/CES for continuing professional education. As such, it does not include content that may be deemed or construed to be an approval or endorsement by the AIA of any material of construction or any method or manner of handling, using, distributing, or dealing in any material or product.*



*Questions related to specific materials, methods, and services will be addressed at the conclusion of this presentation.*





## Copyright Materials

This presentation is protected by US and International Copyright laws. Reproduction, distribution, display and use of the presentation without written permission of AISC is prohibited.

© The American Institute of Steel Construction 2018



## Session Description

### **18.1 Introduction to the Steel Construction Process October 15, 2018**

All parties involved in the steel construction process play a critical role, from the office (structural design, connection design, and erection engineering), to the plant (steel production and fabrication), to the field (erection and quality assurance). Using the AISC Code of Standard Practice as a framework, this session discusses the team of contributors who are responsible for creating a structural steel building.





## Learning Objectives

- Describe the roles and responsibilities of key team members on a structural steel project.
- Describe how understanding and integrating constructability into your building design leads to safe, efficient designs.
- Define the role the AISC Code of Standard Practice has in steel buildings.
- List the different relationship arrangements of team members based on the type of contractual agreement: design-bid-build, design-build, and design-detail.



## Night School 18: Steel Construction

From the Mill to Topping Out

Session 1: Introduction to the Steel Construction Process

October 15, 2018

(The Team Behind the Building)



Andrew Twarek, PE, SE  
Project Manager  
Ruby+Associates, Inc. Structural Engineers  
Bingham Farms, MI



## About Me

 **ruby+associates**

STRUCTURAL ENGINEERS



## Night School 18

- 18.1 **Introduction** to the Steel Construction Process Oct. 15
- 18.2 The **Manufacturing** of Structural Steel Shapes Oct. 22
- 18.3 A Virtual, Detailed Tour of the **Steel Fabrication** Process Oct. 29
- 18.4 **Connection Design** as the Fabricator's Representative Nov. 5
- 18.5 It Doesn't Get Built Without the **Erector** Nov. 19
- 18.6 **Erection Engineering** – Stability During Construction Nov. 26
- 18.7 **Field Fixes** and Solutions Dec. 3
- 18.8 **Quality** Control and Quality Assurance Dec. 10



10



## Outline

1. The Team
2. The Owner/Architect
3. The ODRD (EOR)
4. The ODRC (Construction Manager)
5. The Mill
6. The Fabricator
7. The Detailer
8. The Connection Designer
9. The Erector
10. The Erection Engineer
11. Quality Control



11

## 1. The Team

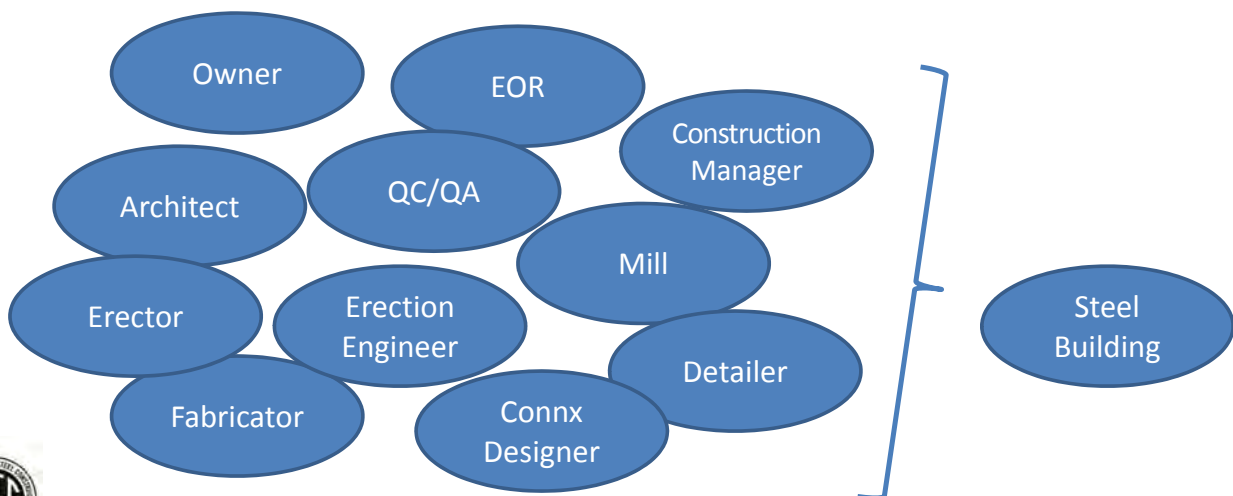

12



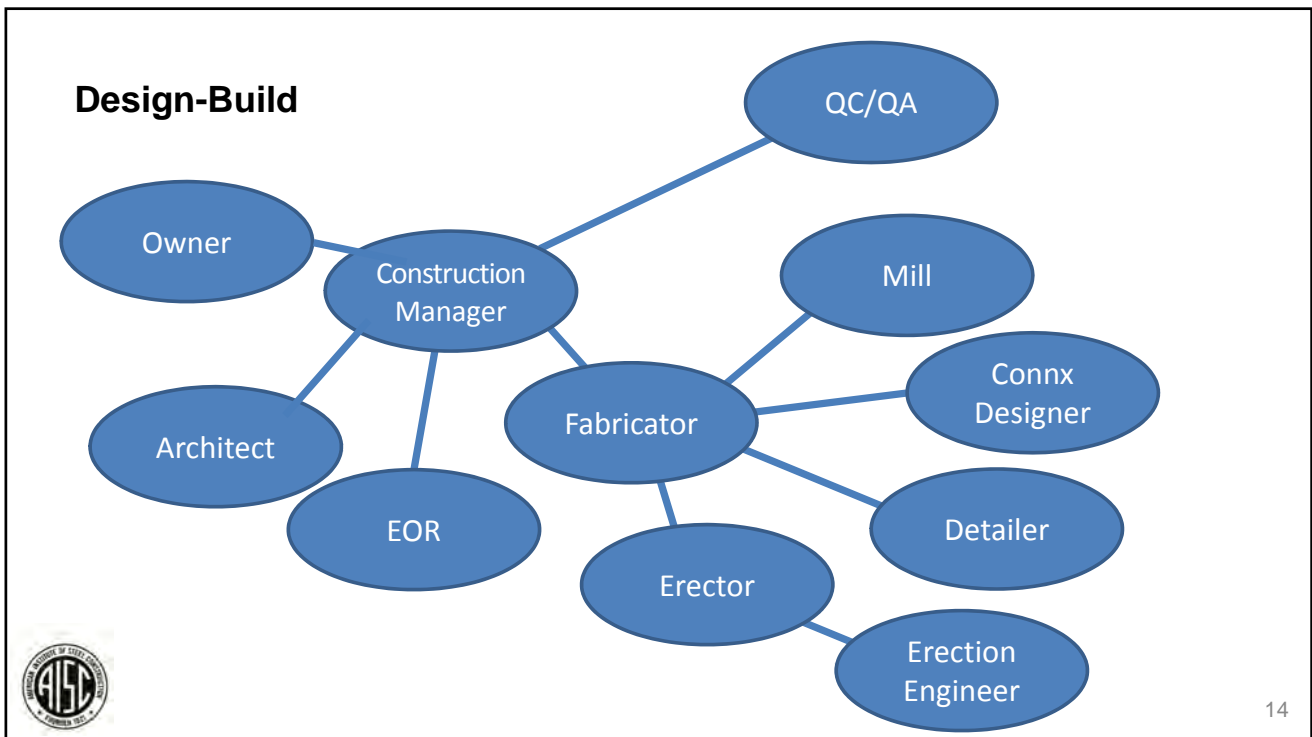
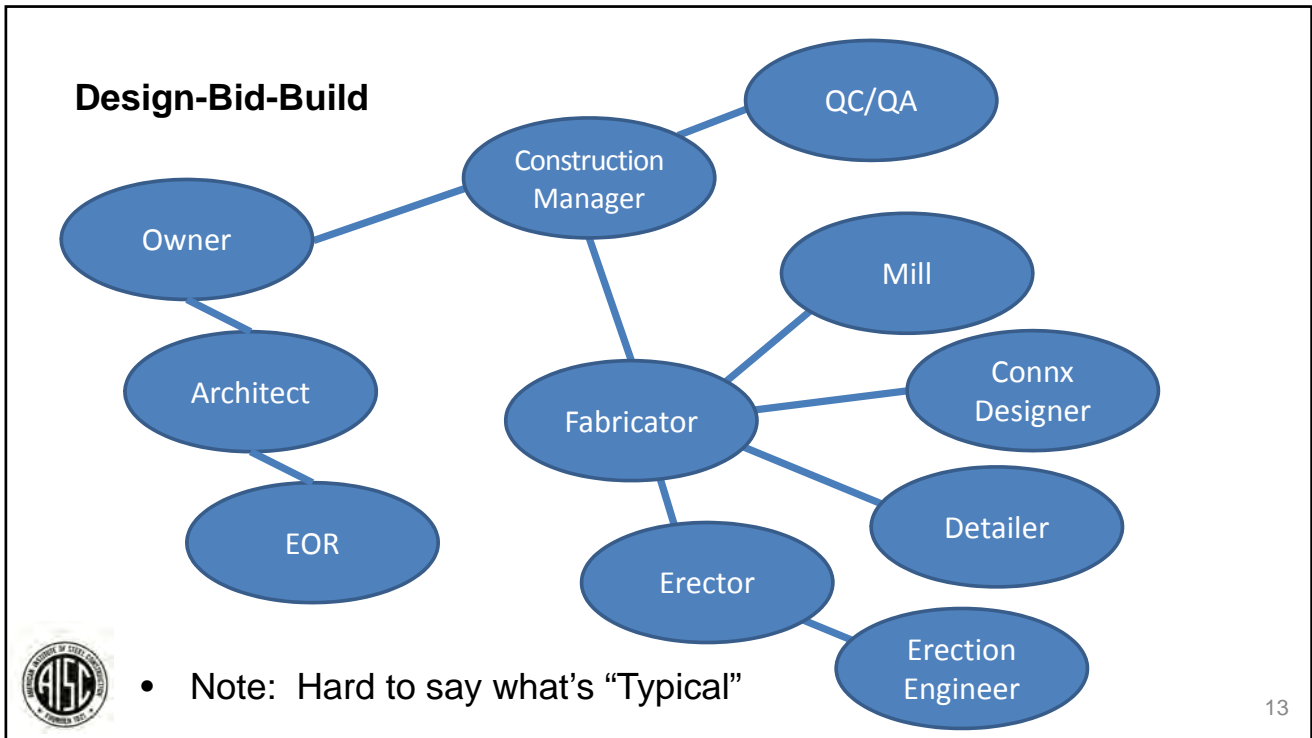

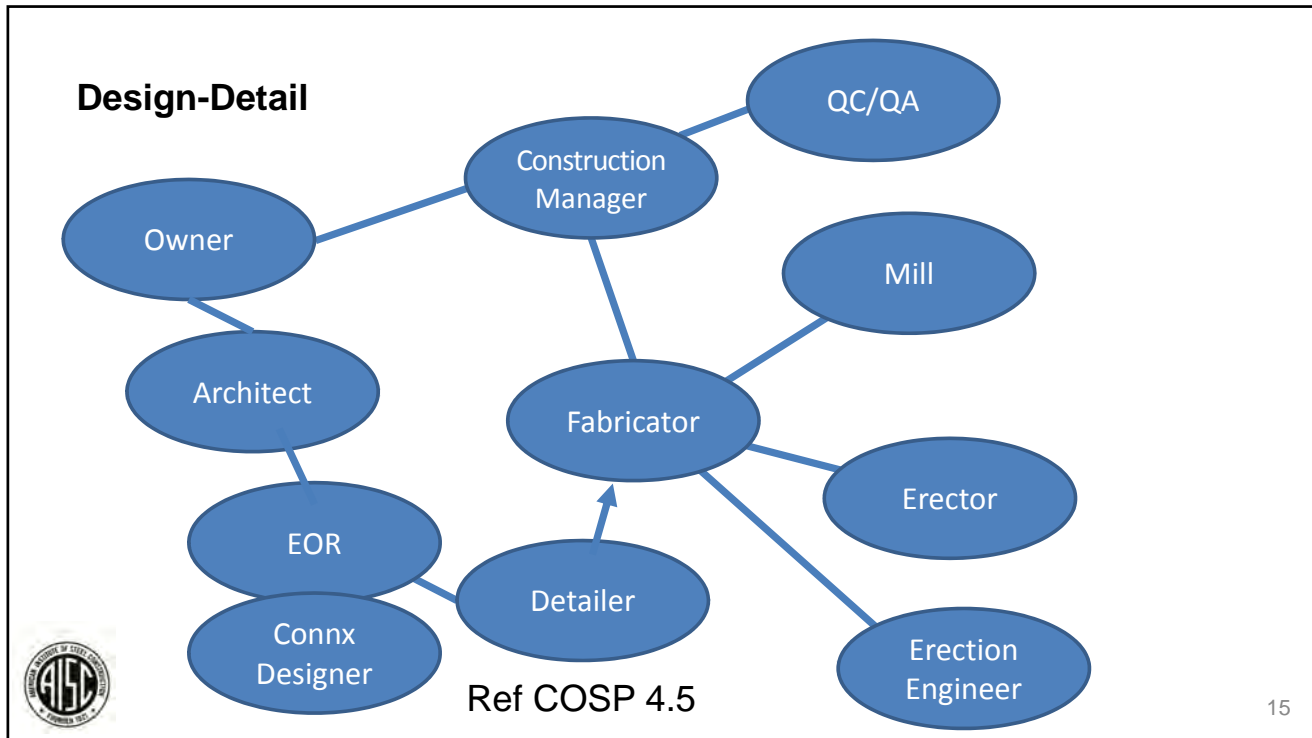



### Other Contractual Arrangements

- **Fast Track Projects**
  - Begin construction before design is complete
  - Not atypical on large projects
  - Design may be conservative (i.e. more costly) at front end, but shortens schedule
  - Occupancy = owner revenue
  - COSP 3.6
- **Design-Fab**
  - Fabricator both designs and fabricates
  - Typical for “Metal Building Systems” (Butler, Nucor)



www.nucorbuildingsystems.com



16

## AISC Code of Standard Practice (COSP)

ANSI/AISC 303-16  
An American National Standard

- Defines "...criteria for the trade practices involved in steel buildings..." (Sec. 1.1)
- Identifies who's responsible for what
- May be modified by contract documents

---

# Code of Standard Practice for Steel Buildings and Bridges

---

June 15, 2016

Supersedes the *Code of Standard Practice for Steel Buildings and Bridges*  
dated April 14, 2010 and all previous versions

Approved by the Committee on the Code of Standard Practice

17



## What is Structural Steel?



## Section 2.1

- Elements of the structural frame, shown & sized in the structural design documents, essential to support the design loads
- Normally furnished by fabricator
  - Anchor rods
  - Base plates\*
  - Beams\*
  - Bearing plates\*
  - Bracing, if permanent
  - Columns\*
  - Connection materials
  - Door frames\*
  - Embedded structural steel parts\*
  - Floor-opening frames\*
  - Girders\*
  - Girts\*
  - Leveling plates
  - Posts\*
  - Purlins\*
  - Tie rods\*

\* "If part of/attached to the structural frame" or "if made from structural shapes or plates"  
Note: See COSP for entire list



18



## What is NOT Structural Steel?

## Section 2.2

- May be furnished by fabricator if contracted to do so
- Cables for permanent bracing
- Castings
- Cold-formed steel products
- Expansion joints\*
- Flagpole support steel
- Gage-metal products
- Grating
- Handrail
- Ladders
- Lintels\*
- Roof screen support frames\*
- Stairs
- Steel deck
- Steel (open-web) joists
- Toe plates



\* "If **not** part of/**not** attached to the structural frame," "if **not** made from structural shapes/plates"  
Note: See COSP for entire list

19

## Outline

1. The Team
2. The Owner/Architect
3. The ODRD (EOR)
4. The ODRC (Construction Manager)
5. The Mill
6. The Fabricator
7. The Detailer
8. The Connection Designer
9. The Erector
10. The Erection Engineer
11. Quality Control



20



## 2. The Owner/Architect

Responsibilities include:

- Determine size, configuration, performance criteria for building
- Provide life safety (maximum occupant load, vertical/horizontal circulation, exits, construction fire rating, etc.)
- Finishes (ceiling, floor, wall covering, furniture layouts and selection, door/window schedule)
- Determine contract arrangement
- Pay for building



21

## Other Trades

- Civil (earthwork)
- Electrical
- HVAC (heating, ventilating, air conditioning)
- Plumbing

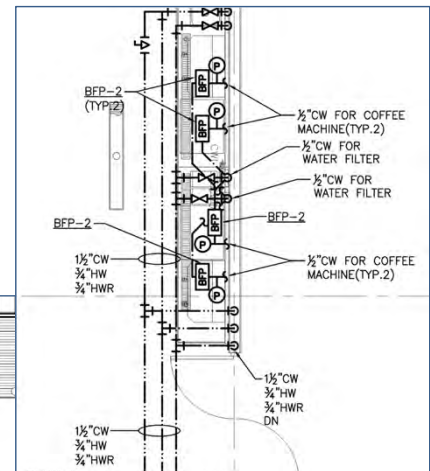
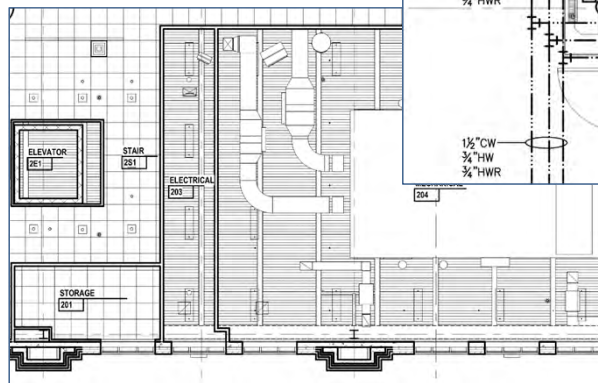
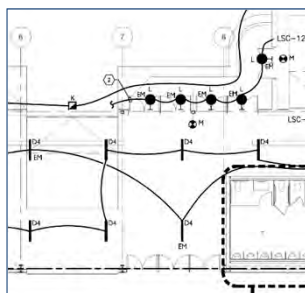

22



## Constructability

- Ability to influence the cost and quality of construction over the life of a project
- Cost and schedule impacts of making changes



# 23

Steel Design Guide

## Constructability of Structural Steel Buildings

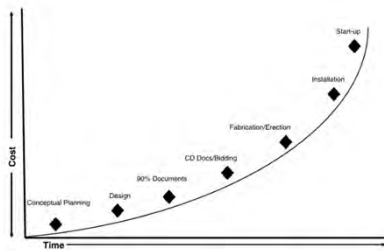
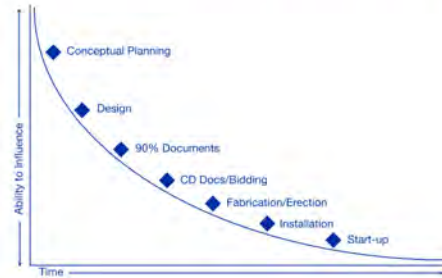
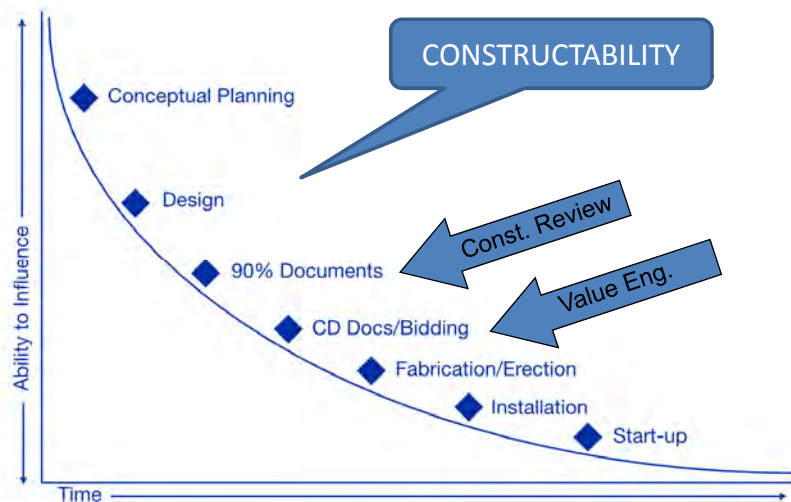

Fig. 1-2. Cost of change over time.



23

## Constructability



24



## Outline

1. The Team
2. The Owner/Architect
3. The ODRD (EOR)
4. The ODRC (Construction Manager)
5. The Mill
6. The Fabricator
7. The Detailer
8. The Connection Designer
9. The Erector
10. The Erection Engineer
11. Quality Control



25

## 3. The ODRD

### Owner's Designated Representative for Design

- Engineer of Record (EOR)
- Responsible for structural adequacy of design (Building Code Compliance)
  - ASCE7 "Minimum Design Loads...for Buildings..."
  - AISC 360 "Specification for Structural Steel Buildings"
  - ACI318 "Building Code Requirements for Structural Concrete"
  - MSJC/TMS402 "Building Code Requirements for Masonry Structures"
  - Etc.

### Section 3

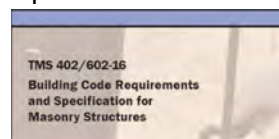
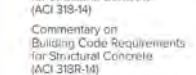
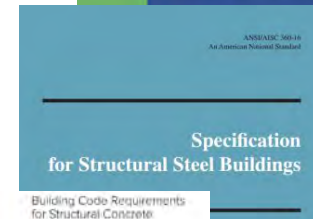

26



## Contract Documents

## Section 3.1

- Define responsibility of the parties involved in bidding, fabricating, erecting structural steel

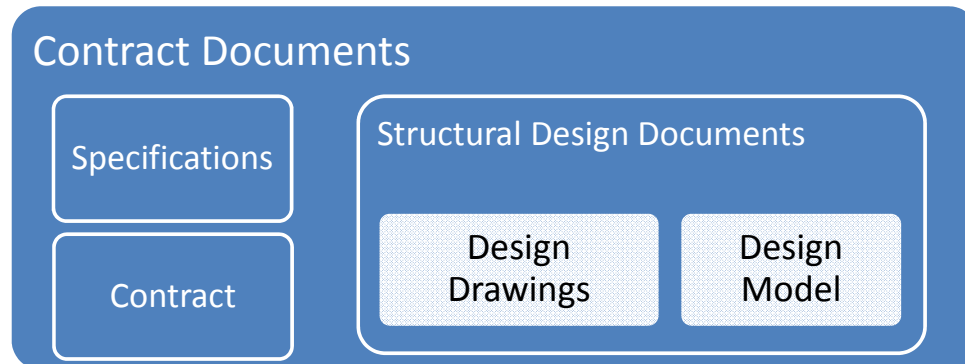

27

## Design Documents

- Schematic Design (SD)
  - Rough sketches and analysis to determine project scope, estimated costs
- Design Development (DD)
  - Engineering design, usually issued in sets (50%DD, 75%DD) to coordinate with owner, architect, other trades, as design is firmed up
  - Mill order – sometimes issued prior to CDs so fabricator can begin to source steel directly from mill
- Construction Documents (CD) – Bid Set
  - Design should be complete with all information fabricator and erector need to provide accurate and complete bids to owner
- Revisions



28



## Design Documents

## Section 3.1

- Basic Requirements (bare minimum)
  - a) The size, section, material grade and location of all members.
  - b) All geometry and working points necessary for layout.
  - c) Floor elevations.
  - d) Column centers and offsets.
  - e) The camber requirements for members.
  - f) Preset elevation requirements, if any, at free ends of cantilevered members relative to their fixed-end elevations.
  - g) Joining requirements between elements of built-up members.
  - h) Information required by AISC341 Section A4.
- Special limitations, fab/erect tolerances, AESS\* (Section 10)



29

## Design Documents

## Section 3.1

- Connection Design Information (3.1.1)
  - Three options (More later!)
- Lateral Force Resisting System (7.10.1)
  - Must define the LFRS and connecting diaphragm elements (both steel and nonsteel) so stability of the structure is clearly understood.
- Non-Structural Steel Elements in LFRS (3.1.4)
  - “When the [completed] structural steel frame...requires interaction with non-structural steel elements (see Section 2) [sic] for strength and/or stability, those non-structural steel elements shall be identified in the contract documents as required in Section 7.10.”

*All lateral force resistance and stability of the building in the completed structure is provided exclusively by cast-in-place reinforced concrete shear walls in the building core and stairwells (see plan sheets for locations). These walls provide all lateral force resistance in each orthogonal building direction. The composite metal deck and concrete floors serve as horizontal diaphragms that distribute the lateral wind and seismic forces horizontally to the concrete shear walls. The concrete shear walls carry the applied lateral loads to the building foundation.*



30



## Design Documents

## Section 3

- Criteria for Specialty Structural Engineer (SSE)
  - Load, deflection, performance requirements for “buy out” items such as:
  - Joists
  - Proprietary Connections
    - Structural Castings
    - Manufactured Moment Connections
    - Buckling-Restrained Braces

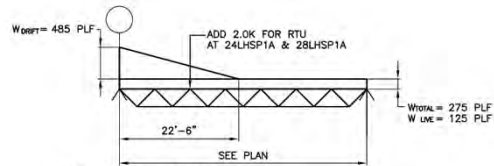

24LHSP1, 24LHSP1A,  
 28LHSP1, & 28LHSP1A LOADING DIAGRAM  
 NO SCALE

Example joist special loading diagram



Buckling restrained brace, sciencedirect.com



## Outline

1. The Team
2. The Owner/Architect
3. The ODRD (EOR)
4. The ODRC (Construction Manager)
5. The Mill
6. The Fabricator
7. The Detailer
8. The Connection Designer
9. The Erector
10. The Erection Engineer
11. Quality Control



## 4. The ODRC

### Owner's Designated Representative for Construction

- General Contractor (GC)
- Construction Manager (CM)
- Responsible for "...the overall construction of the project, including its planning, quality, and completion." (Glossary)
- Maintains latest contract documents and other information flow and Requests for Information (RFI's) between parties
- Manages construction budget



33

### ODRC

- Provides material access and workable jobsite conditions
- Also responsible for prepwork:
  - Foundations,
  - Lines & benchmarks
  - Anchor bolts installation
  - Leveling plates/loose base plates (not requiring a crane)
- Column base grouting

### Section 7



Photo by Ben Hur, Inc.



34



## Outline

1. The Team
2. The Owner/Architect
3. The ODRD (EOR)
4. The ODRC (Construction Manager)
5. The Mill
6. The Fabricator
7. The Detailer
8. The Connection Designer
9. The Erector
10. The Erection Engineer
11. Quality Control



35

## 5. The Mill

- Responsible for transforming raw materials into new steel, controlling chemistry, creating (rolling) shapes suitable for steel construction
- Uses iron (produced from ore in a blast furnace) and/or scrap steel
- Iron – more than 2% carbon
- Steel – 0.05% - 1% carbon (structural typically less than 0.25%)



Photo by Rio Grand Guardian



36



## Steel Production Process

- Electric Arc Furnace –
  - “Minimill” – smaller batches made using mostly scrap steel
  - Virtually all of US structural shape production
  - Much more adaptable to vary production
  - Can be located near markets

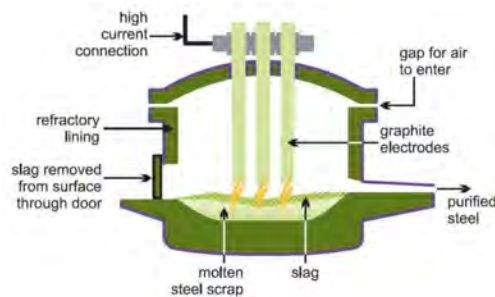

www.sfsa.org/sc3/downloads/E14\_Steel\_Castings\_in\_Architecture.pdf (NASCC 2017)

Photo by Steel Dynamics

## Steel Recycles!

- Structural steel production in US averages 93% recycled scrap steel
- At the end of a building’s life, 98% of all structural steel is recycled into new steel products

(statistics by AISC)

**Recycled Content** – LEED 2009 MR 4; LEED v4 MR Credit: Sourcing of Raw Material

2017 Recycled Steel Content of Nucor Products (% by Total Weight)	
Product Group	Average Recycled Content
Nucor Bar Products	96.1%
Nucor Engineered Bar Products	86.5%
Nucor Beam Products	80.7%
Nucor Plate Products	63.1%
Nucor Sheet Products	58.9%
Nucor Castrip®	86.0%
<b>Total Nucor Steel Combined</b>	<b>72.6%</b>
Vulcraft Structural Products	96.1%
Vulcraft / Verco Decking	58.9%
Nucor Grating / Fisher-Ludlow Grating	96.1%
Nucor Building Group	72.6%
Harris Rebar	96.1%
Nucor Fastener Products	96.1%
Nucor Wire Products	96.1%
Nucor Cold Finish	86.5%



38



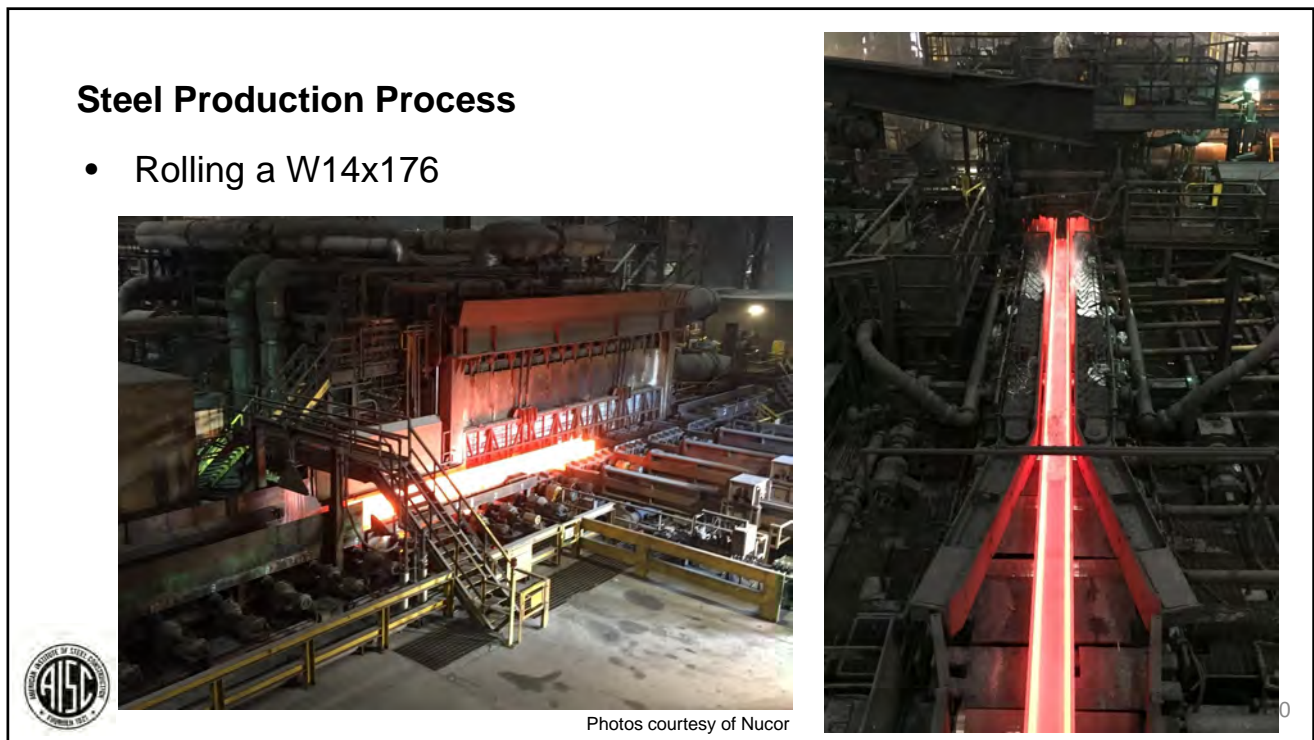
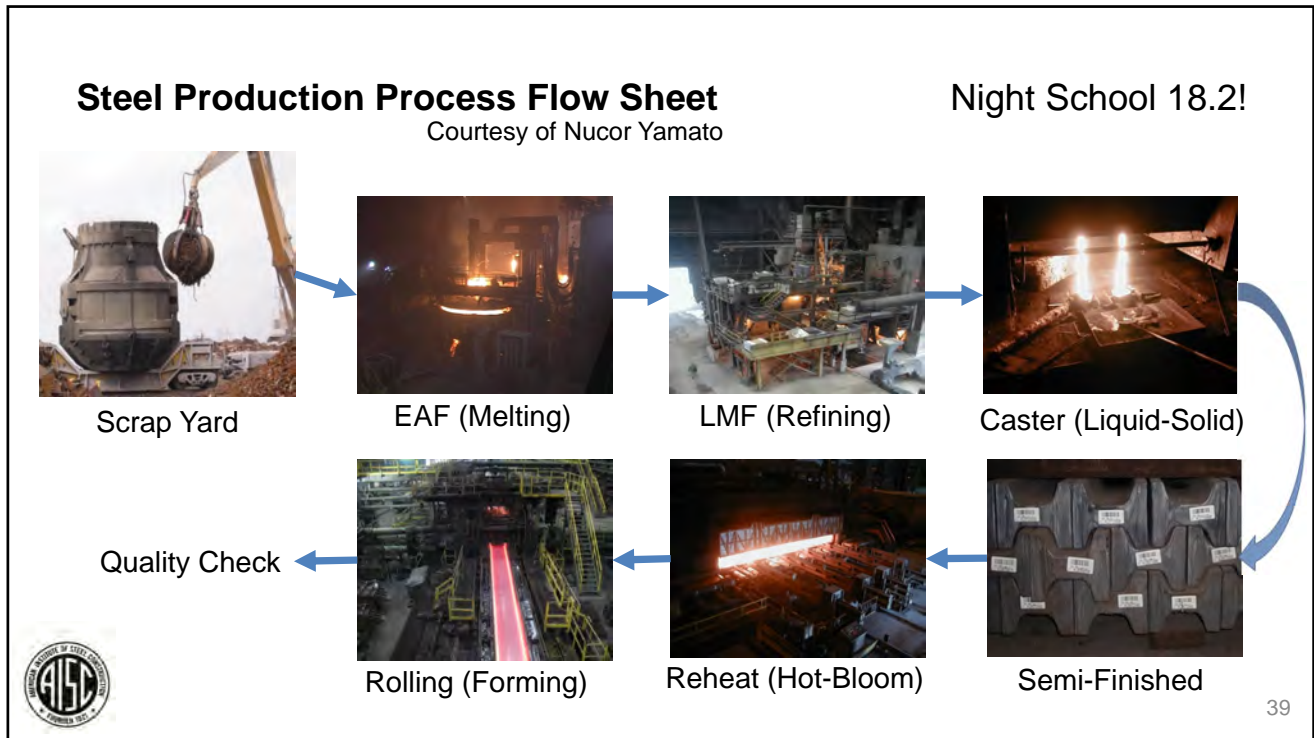

## Steel Production Process

Photo courtesy of Nucor

View from the gondola



41

## Steel Chemistry (A992 maximums, e.g.)

- Carbon 0.23% Fundamental ingredient in steel. Increases yield strength, hardness
- Silicon 0.4% Deoxidation, increases tensile strength
- Vanadium 0.15% Finer grains, less weldability, better wear resist
- Sulfur 0.045% Can cause cracking
- Manganese ~1% Neutralizes sulfur, deoxidation
- Nickel 0.45% Reduce brittleness, increase toughness
- Chromium 0.35% Hardening, corrosion resistance (high amounts)
- Molybdenum 0.15% Hardening, increase tensile strength



42



### Preferred Grades

- Wide Flange – ASTM A992
- HSS – ASTM A500 Gr. C or A1085
- A36 still default steel for:
  - Standard and Misc. I shapes
  - Channels and MCs
  - Angles
- Plate
  - ASTM A36 or ASTM A572 Gr. 50
  - Often no surcharge for 50 ksi plate
  - No reason not to take advantage of it!



**Table 2-4**  
**Applicable ASTM Specifications for Various Structural Shapes**

Steel Type	ASTM Designation	F <sub>y</sub> Yield Stress <sup>a</sup> (ksi)	F <sub>u</sub> Tensile Stress <sup>a</sup> (ksi)	Applicable Shape Series												
				W	M	S	HP	C	MC	L	Rect. HSS	Round HSS	Pipe			
Carbon	A36	36	58-80 <sup>b</sup>													
	A500	Gr. B	42	58												
			46	58												
	Gr. C	46	62													
		50	62													
	A501	Gr. A	36	58												
			50	70												

**Table 2-5**  
**Applicable ASTM Specifications for Plates and Bars**

Steel Type	ASTM Designation	F <sub>y</sub> Yield Stress <sup>a</sup> (ksi)	F <sub>u</sub> Tensile Stress <sup>a</sup> (ksi)	Plates and Bars, in.											
				to 0.75 incl.	over 0.75 to 1.25 incl.	over 1.25 to 1.5 incl.	over 1.5 to 2 incl.	over 2 to 2.5 incl.	over 2.5 to 4 incl.	over 4 to 5 incl.	over 5 to 6 incl.	over 6 to 8 incl.	over 8		
Carbon	A36	32	58-80												
		36	58-80												
	A283 <sup>c</sup>	Gr. C	30	55-75											
			Gr. D	33	60-80										
	A529	Gr. 50	50	65-100											
			Gr. 55	55	70-100										
	A709	Gr. 36	36	58-80											
			Gr. 42	42	60										
	A572	Gr. 50	50	65											
			Gr. 55	55	70										

### Preferred Grades

- Bolts**
- Group A - 120ksi
    - A325, A325M, F1852
  - Group B - 150ksi
    - A490, A490M, F2280
  - Group C - 200ksi
    - “XTB”, ASTM F3043 and F3111
  - ASTM F3125 Grade A325, e.g.



**Table 2-6**  
**Applicable ASTM Specifications for Various Types of Structural Fasteners**

ASTM Designation	F <sub>y</sub> Min. Yield Stress (ksi)	F <sub>u</sub> Tensile Stress <sup>a</sup> (ksi)	Diameter Range (in.)	Bolts			Washers			Anchor Rods		
				Conventional	High-Strength	Common Bolts	Nuts	Hardened	Plain	Direct-Tension Indicator	Threaded Rods	Hooked
F3125	Gr. A325 <sup>d</sup>	120	0.5 to 1.5									
	Gr. F1852 <sup>e</sup>	120	0.5 to 1.25									
	Gr. A490 <sup>d</sup>	150	0.5 to 1.5									
	Gr. F2280 <sup>e</sup>	150	0.5 to 1.25									
F3111	200	1 to 1.25 incl.										
F3043	200	1 to 1.25 incl.										
A194 Gr. 2H	–	–	0.25 to 4									
A563	–	–	0.25 to 4									
F436	–	–	0.25 to 4 <sup>h</sup>									
F844	–	–	any									
F959	–	–	0.5 to 1.5									
A36	36	58-80	to 10									
F1554	Gr. 36	36	58-80									
	Gr. 55	55	75-95									
	Gr. 105	105	125-150									



### Steel Availability

- AISC website lookup
- More producers = more common
- May still need to check rolling schedule

→ ↻ 🏠 <https://www.aisc.org/steelaavailability/search-results/?shape=W||A7>

**AISC MEMBERS**

W Shapes	Grade	Gerdau AmeriSteel	Nucor- Berkeley	Nucor- Yamato Steel Co.	Steel Dynamics
4 x 13 x 4	A992	✓	✓		✓
4 x 13 x 4	A709				✓
5 x 16 x 5	A709				✓
5 x 16 x 5	A992		✓		✓
5 x 19 x 5	A992		✓		✓
5 x 19 x 5	A709				✓
6 x 8.5 x 4	A709				✓
6 x 8.5 x 4	A992	✓	✓		✓
6 x 9 x 4	A992	✓	✓		✓
6 x 9 x 4	A709				✓
6 x 12 x 4	A709				✓
6 x 12 x 4	A992	✓	✓		✓



### Rolling Schedules / Advanced Bill of Materials (ABM)

- Shapes only rolled every several weeks
- To get “first choice” of mill products, fabricator must purchase via mill order. Important to get accurate ABM from fabricator. EOR must lock member sizes, lengths.

Nucor-Yamato Proposed Roll/Close Schedule \* ISO 9001:2015 Registered \* October 10, 2018  
Inquire items are followed immediately by the last order date of the book week if available — Highlighted items will close in the next week

Week Beginning		7-Oct	14-Oct	21-Oct	28-Oct	4-Nov	11-Nov	18-Nov	25-Nov	
NYS Fiscal Week		41	42	43	44	45	46	47	48	
<b>Wide Flange Sections</b>	<b>Mill #</b>									<b>Projected next roll week</b>
W44x16x230-335	2							47 I		1/27-2/3 Wks
W40x16x199-593	2							47 I		1/27-2/3 Wks
W40x12x149-392	2		42 C					47 I		12/23-12/30 Wks
W36x17x487-652	3								48 I	1/27-2/3 Wks
W36x16.5x231-441	2		42 C	42 C					48 I	12/23-12/30 Wks
W36x12x135-256	2			42 C	42 C				48 I	12/23-12/30 Wks
W33x15.75x201-387	2			42 C	42 C				48 I	12/23-12/30 Wks
W33x11.5x118-169	2			42 C	42 C				48 I	12/23-12/30 Wks
W30x15x173-433	2			43 C					48 I	12/23-12/30 Wks
W30x10.5x90-148	2			43 C					48 I	12/23-12/30 Wks
W27x14x146-368	3			43 C	43 C				48 I	12/23-12/30 Wks
W27x10x84-129	2				43 C				48 I	1/30-1/6 Wks
W24x12.75x104-370	2				44 C					1/23-1/29 Wks
W24x9x56-103	2				44 C					1/23-1/29 Wks
W24x7x55-62	1					44 C				12/23-12/30 Wks
W21x12.25x101-275	2					44 I 10/15				1/6-1/13 Wks

I = Inquire    O = Open    PS = Planned Stock    SA = Subject to Accumulation    E = Controlled    C = Closed



## Service Centers

- Steel not purchased via mill order may come from fabricator stock or steel service center
- Expensive to keep stockpile of steel in fabricator's yard
- Service center can order in bulk, pass along savings (along with warehousing, handling costs)
- Service center may sell steel marked, cut to length, ready for fab



<https://www.ryerson.com/services/what-we-do>



47

## Outline

1. The Team
2. The Owner/Architect
3. The ODRD (EOR)
4. The ODRC (Construction Manager)
5. The Mill
6. The Fabricator
7. The Detailer
8. The Connection Designer
9. The Erector
10. The Erection Engineer
11. Quality Control



48



## 6. The Fabricator

Section 6

- Turns steel stock into assemblies for site installation
- Main point of contact for steel supply per COSP
  - Sources steel, as well as other “buy out” items like bolts
  - Usually holds contract for connection designer and detailer
  - Must sequence work with erector to avoid storing too much material (especially at a busy jobsite)



49

## Fabrication Process

Night School 18.3!

- Quick overview of fabrication shop stations
- Shops vary in level of complexity and automation – everywhere between fully manual and fully computer-controlled
- Photos courtesy of Voortman and Cianbro Corporation



50



### Cutting – Bandsaw

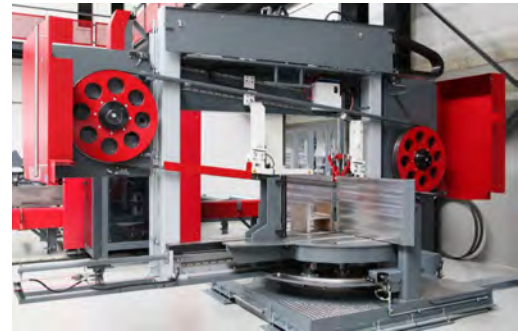

### Holes – Drilling

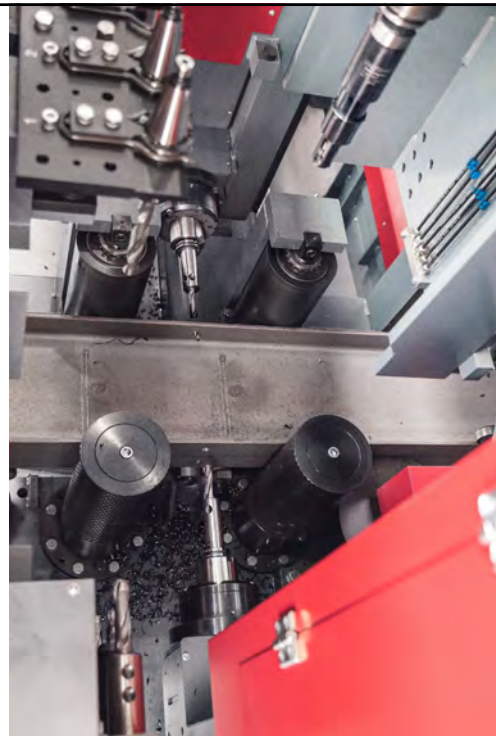
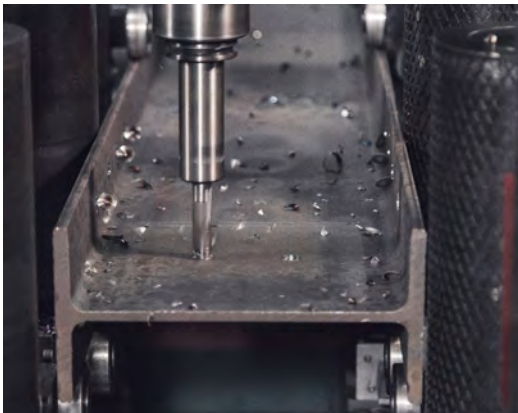

52



### Holes – Drilling



53

### Holes – Punching (and Shearing)



54



## Coping

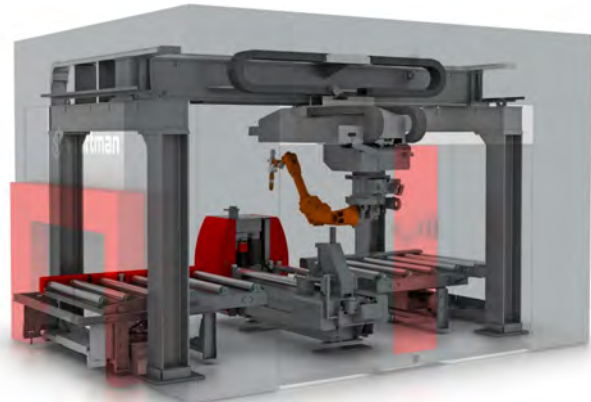

55

## Coping



56



### Plate Work – Plasma Table

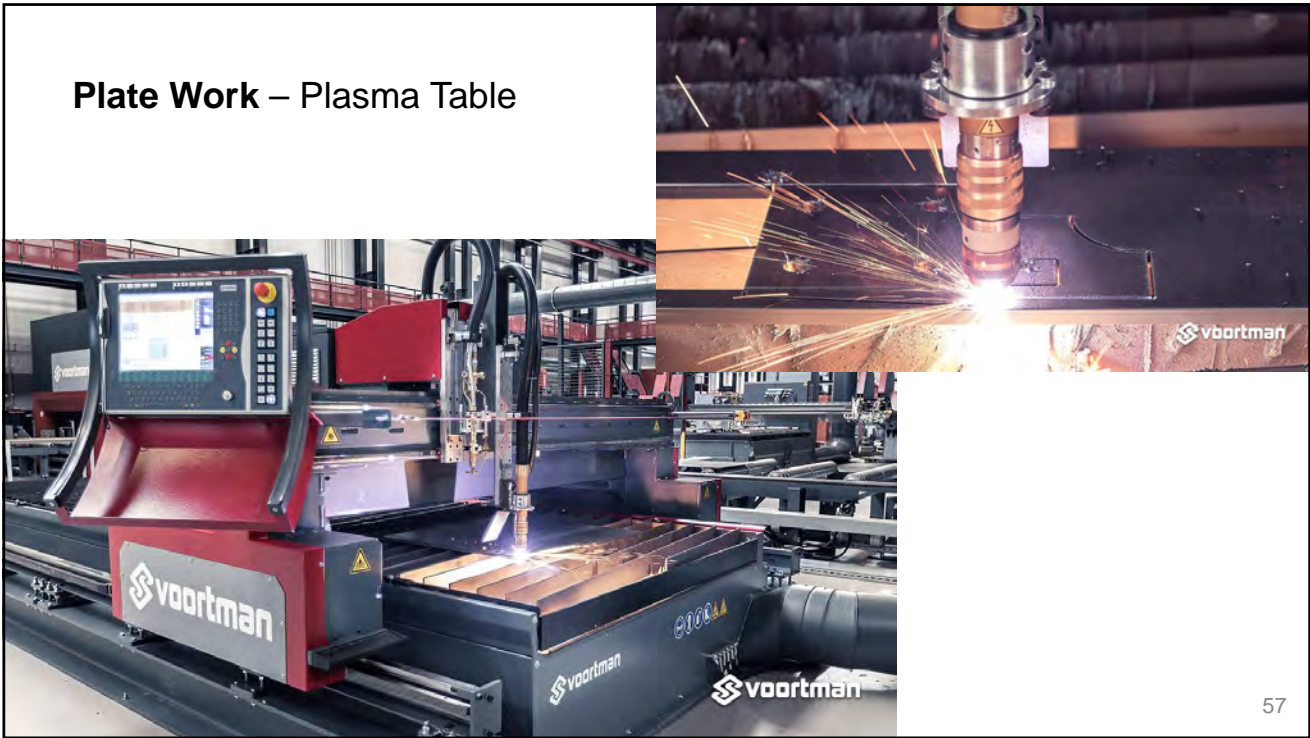

57

### Layout

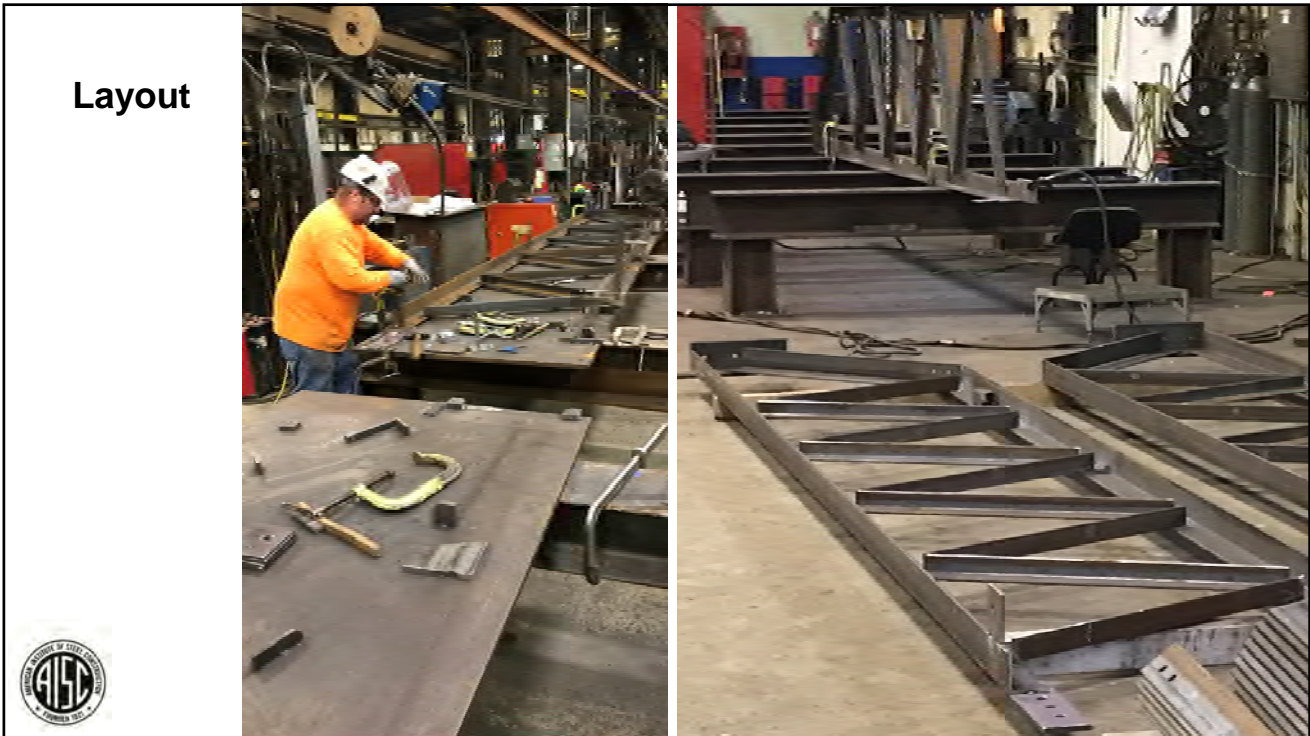

## Welding



## Blasting



### Painting



61

### Shipping

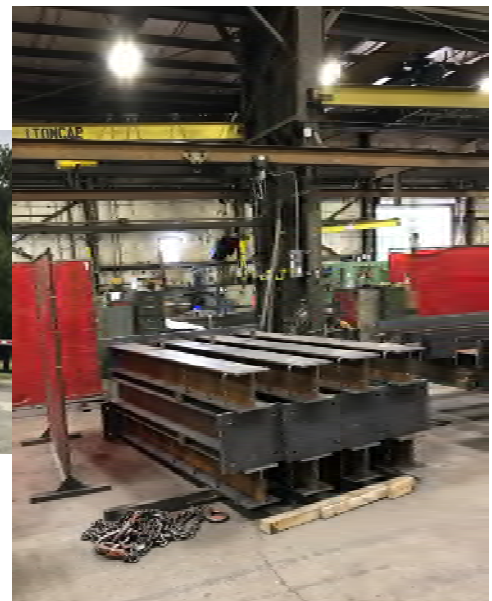

62



## Outline

1. The Team
2. The Owner/Architect
3. The ODRD (EOR)
4. The ODRC (Construction Manager)
5. The Mill
6. The Fabricator
7. **The Detailer**
8. The Connection Designer
9. The Erector
10. The Erection Engineer
11. Quality Control



63

## 7. The Detailer

Section 4

- Produces *approval documents* for structural steel from ODRD design documents
- Structural steel shop drawings & erection drawings—and/or digital fabrication & erection models
- Often hired by fabricator – Can work to the strengths of the fabricator (shop welded vs. shop bolted, connection types, marking scheme, phasing/sequencing)
- Input from connection designer



64



### Historic Detailing

- Hand drawn
- To scale
- Complex drawings
- Combined parts (Right/Left)

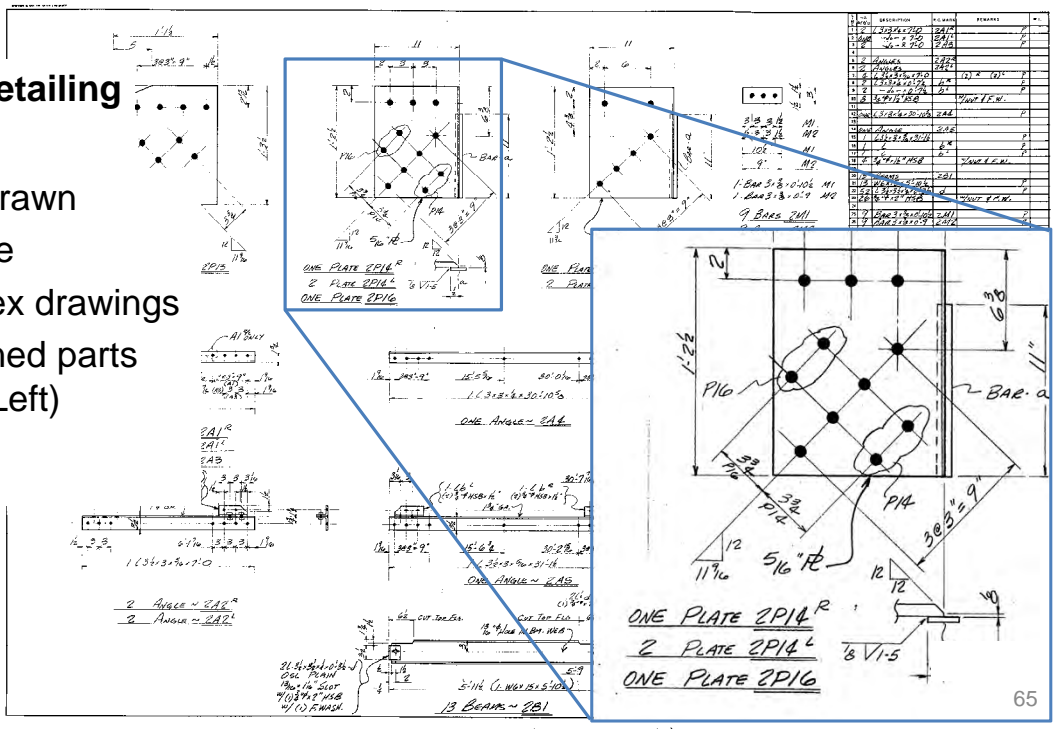

### Historic Detailing

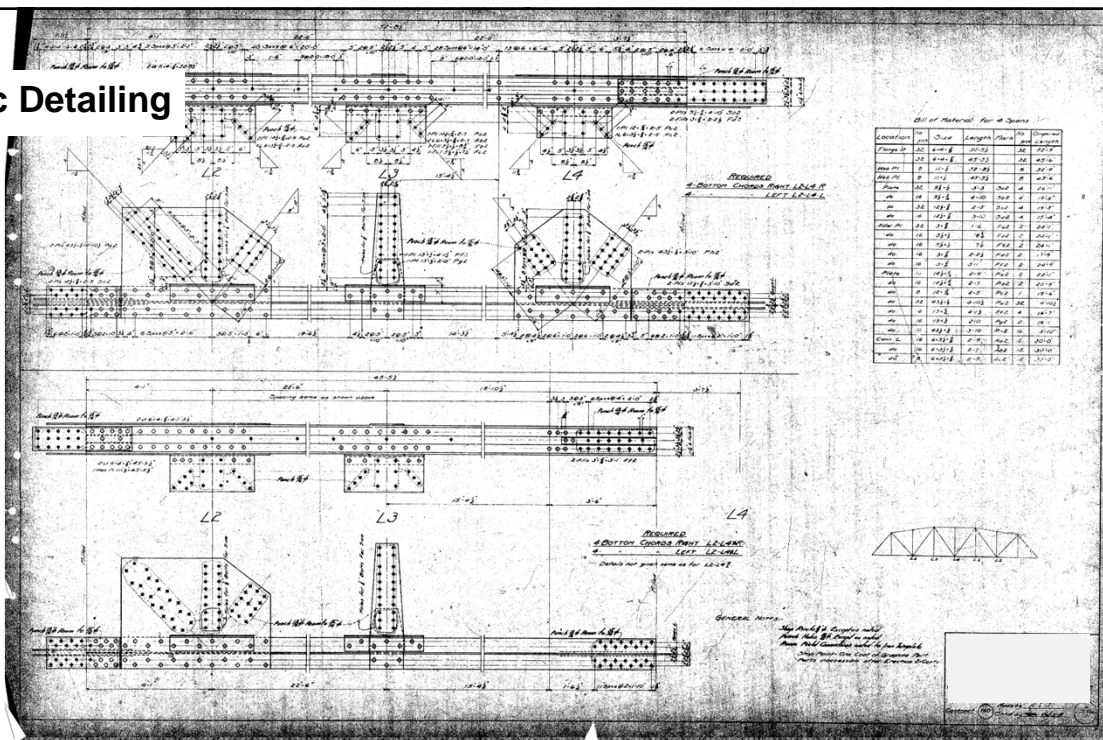

## Modern Detailing

- BIM = Building Information Modeling
- Full steel structure modeled in 3D software (Tekla, SDS/2)
  - Sometimes using input from design model, but often built from scratch
- Phasing, scheduling can be built in via user-defined attributes
- Computer-generated drawings are a “snapshot” of the model
- Many thousands of drawings, transmitted and reviewed electronically
- Coordinate with other trades working in 3D

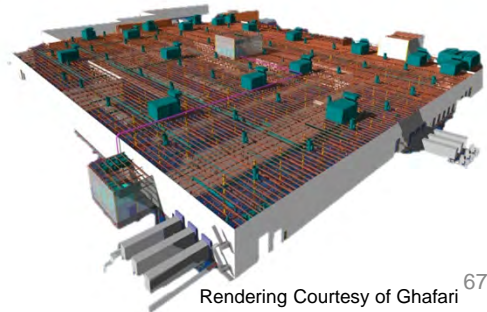

Rendering Courtesy of Ghafari 67



## Part Drawings

- Show information required to fabricate a single piece of steel (gusset plate, connection angle, etc)
- Gather sheet – collection of part details
- Computer generated CNC files, DXF files

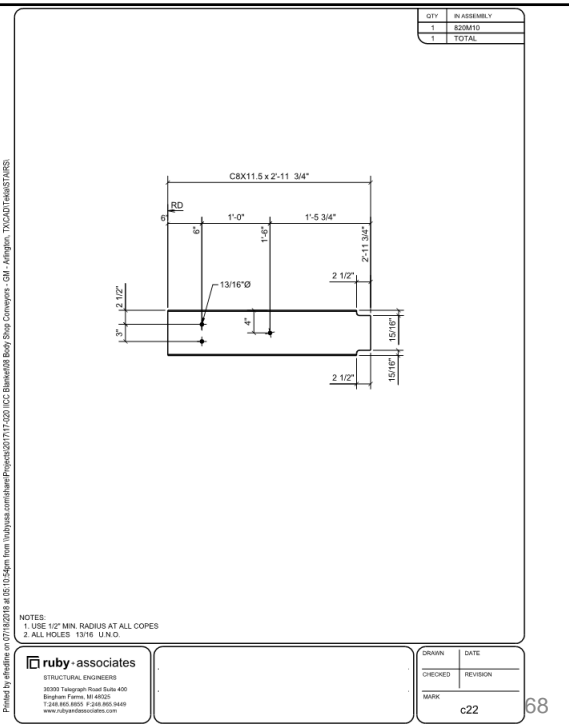

## Assembly Drawings

BILL OF MATERIAL					
MARK	QTY	DESCRIPTION	LENGTH	WEIGHT	REMARKS
B212	1	BEAM			
w21	1	WBX35	19'-1 3/4"	871	A690
p13	6	PL3/8X33"	0'-7 1/8"	17	A36
p14	1	PL1'X12"	1'-1 1/8"	38	A36
TOTAL WEIGHT THIS DRAWING				723	

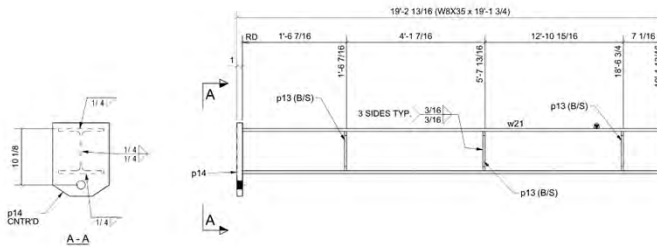

- Show shop assembled fabrications (beam with end connections, gusset plates, etc.)



Shop Notes  
 1) SEE B.O.M. FOR MATERIAL GRADE  
 2) SHOP CONNECTIONS WELDED WITH E70 ELECTRODES  
 3) ALL BEAMS NATURAL CAMBER UP  
 4) ALL HOLES 1/8" DIA. UNLD.  
 5) 1/2" MIN. RADIUS AT ALL COPIES  
 6) USE DIMENSIONS ONLY - DRAWING NOT TO SCALE  
 7) ALL RUNNING DIM'S ARE FROM END OF MAIN MEMBER (REF. R.D.)  
 8)  $\nabla$  SYMBOL DENOTES MARK END  
 9) SURFACE PREP: COORD. BY DRAWER  
 PAINT: COORD. BY OWNER

Mark	Description	Date

**ruby + associates**  
 STRUCTURAL ENGINEERS  
 3330 Telegraph Road, Suite 400  
 Brighton Farms, NY 11703  
 T 248.880.8000 F 248.880.8488  
 www.rubyassociates.com

Project: \_\_\_\_\_  
 Sheet Title: \_\_\_\_\_

Drawn	Project
JH	
Checked	Revision
ABT	
Drawing	
B212	69

## Truss Drawing

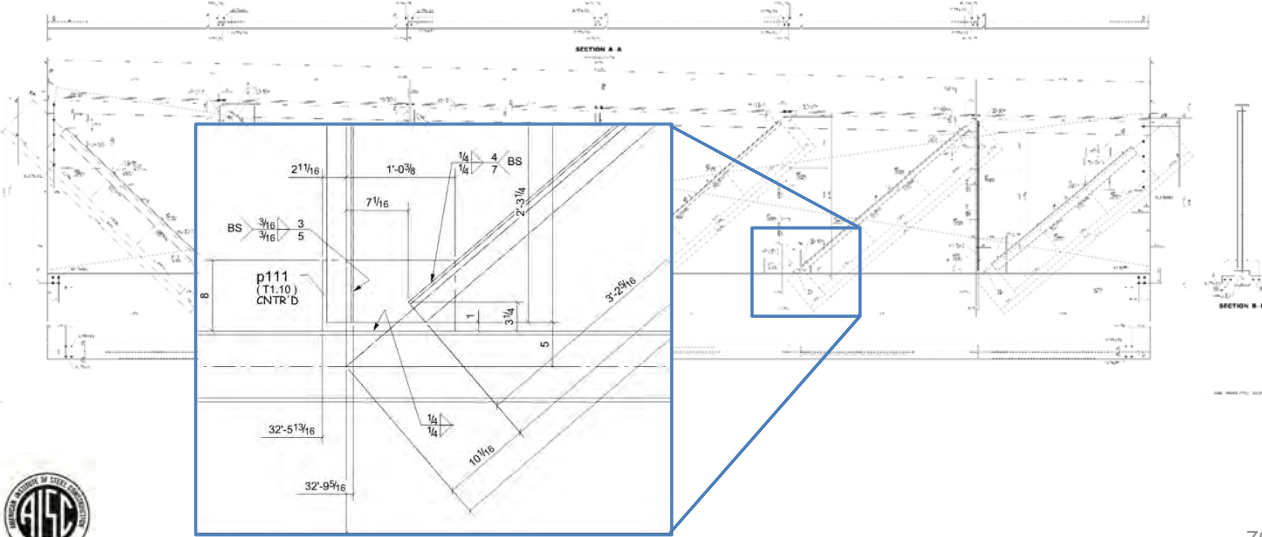

70



## Erection Drawings

- Instructions for field installation
- Show enough detail that erector can put everything in place and connect it, but no “design” information



## Erection Drawings

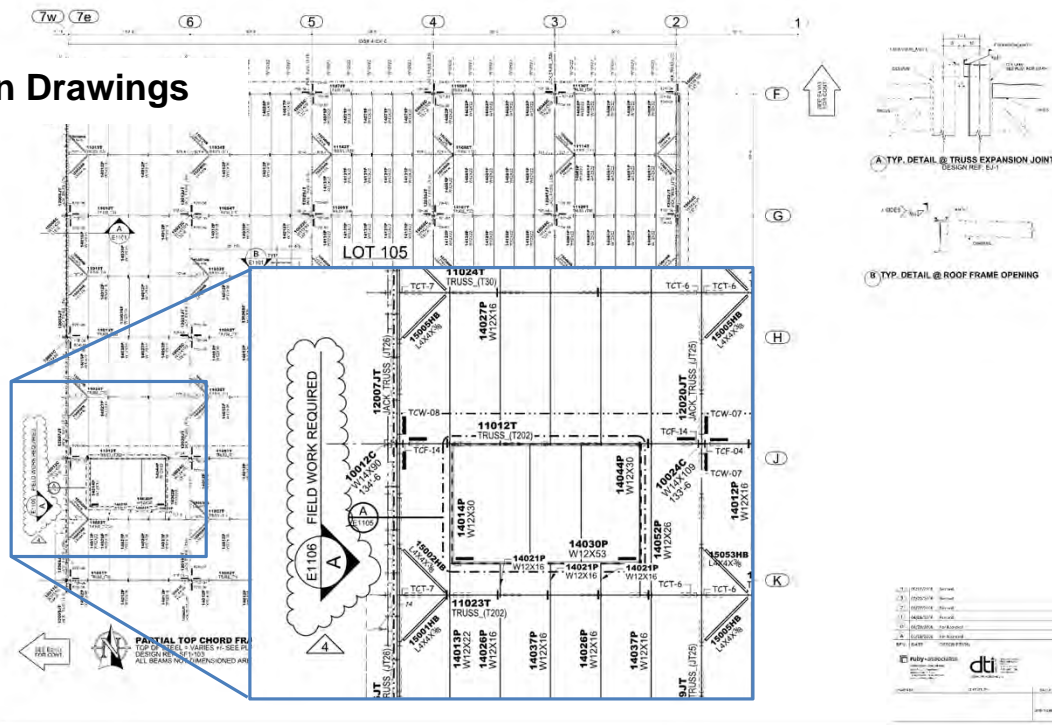

## Approval Document Review

## Section 4

- Owner required to deliver design documents
  - Expected to be “Frozen” or “Locked Layout” so detailing can proceed smoothly
- Fabricator required to produce approval documents
- Shop detail drawings and E-sheets – or model can be used as approval document and reviewed along with/instead of drawings
- Reviewed by ODRD & ODRC (Sec. 4.4)
  - Confirmation fabricator has correctly interpreted contract documents
  - Confirmation ODRD has reviewed & approved connection details
  - Release to begin fabrication
- Fabricator still responsible for accuracy of dimensions, general fitup



73

## Outline

1. The Team
2. The Owner/Architect
3. The ODRD (EOR)
4. The ODRC (Construction Manager)
5. The Mill
6. The Fabricator
7. The Detailer
8. The Connection Designer
9. The Erector
10. The Erection Engineer
11. Quality Control



74



## 8. The Connection Designer

Night School 18.4!

- Designs connections...
- Can be provided in-house by EOR, or contracted by owner, fabricator, or detailer



AISC Steel Sculpture, Polytechnic University of Puerto Rico 75



## Three Connection Design Options

Section 3.1.1

- Option 1: The complete connection design shall be shown on the structural design documents.
- Option 2: The connection shall be designated to be selected or completed by an experienced steel detailer.
- Option 3: The connection shall be designated to be designed by a licensed engineer.
  - Option 3A vs 3B



76



### Option 1 – Shown on design documents

- Connection design performed as part of the EOR team
- Almost always used on west coast, especially in seismic design where EOR needs more control of connections



77

### Option 2 – Selected/completed by detailer

- EOR to provide:
  - Loads that are to be resisted at each connection
    - “% of UDL” (% of maximum capacity per AISC load tables) is discouraged
  - Whether LRFD or ASD is to be used
  - Any restrictions on the types of connections permitted
  - What substantiating information must be provided with approval documents
- Loads can be provided on drawings, tables, or in design model.
- Intent is that detailer selects connection materials from tables (AISC Manual section 9, e.g.)
- Per commentary, not intended “...when the practice of engineering is required.”



78



### Option 3 – Delegated Connection Design

- During the 1960s, fabricators were switching from rivets to bolts and welding, and offered to EORs that they could design their own connections
- Why delegate?
  - Connections can be hard! Connection design can be very specialized
  - Fabricators have different preferences
  - Take advantage to provide economy to project
- Finally added to COSP in 2010



Ruby+Associates

79



### Option 3A/3B – Member Reinforcing

#### Section 3.1.2

- Member reinforcing  $\neq$  connection design
- EOR **shall** provide design of web openings, bearing stiffeners, doublers, and other reinforcement **away** from connections
- **Option 3A** – EOR designs all member reinforcement at connections
- **Option 3B** – EOR provides project-specific conceptual details and estimated quantity for bidding purposes
- “Clean Columns” may save cost over reinforcing
  - AISC Spreadsheet at [www.steeltools.org/column.php](http://www.steeltools.org/column.php)

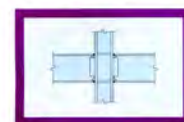

80



### Option 3 – Approval Documents

Section 3.1.1(3)

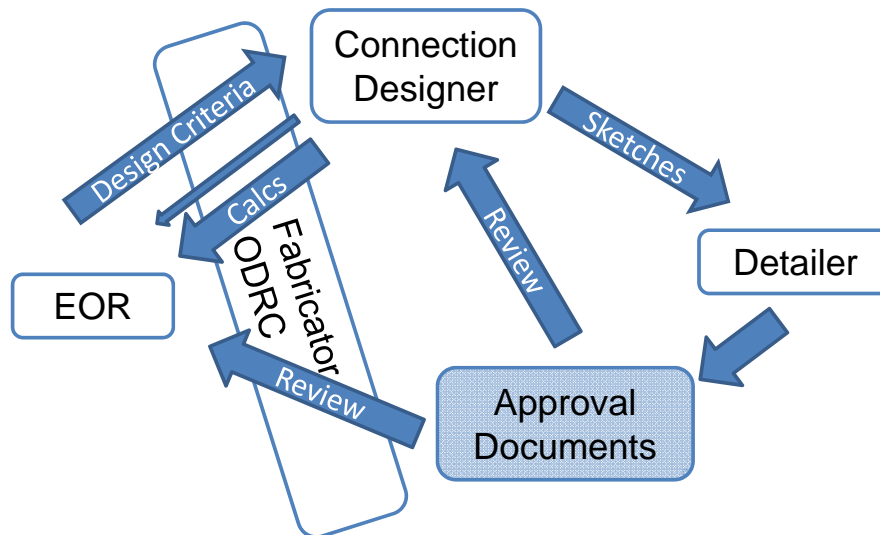

81

### Option 3 – Delegated Connection Design

- May be used for only a portion of the design
  - Shear connections may be selected from tables or computer-designed (SDS/2, Qnect, Giza, etc.)
  - Bracing or truss connections are commonly delegated
- Substantiating information may vary from a signed and sealed cover letter, to full calculation package
  - Representative samples reviewed before preparation of full set
- Each sheet of shop and erection drawings should not be sealed by a PE (Commentary 3.1.1(3))



82



## Types of Connections – Reference Information

[www.aisc.org/dg](http://www.aisc.org/dg)

- Bolts
- Welds
- Simple Shear
- Moment
- Bracing
- Column Base



## Coordination with Fabricator

- Connection designer must work closely with fabricator, detailer, and erector (and EOR) to provide efficient designs
  - Bolt sizes & grades: Maintain few bolt types, preferably each type is a different size, preferably skip 1/8" increments  
e.g. 3/4" dia. Group A and 1" dia. Group B
  - Hole types: Standard, short slot, or oversized for ease of erection
  - Welding preferences: Shop or field, preferred process and groove type
  - Shear connection preferences: single angle, shear tab, extended shear tab
  - Moment connection preferences: flange plate vs direct, welds vs bolts, etc.



84



## Outline

1. The Team
2. The Owner/Architect
3. The ODRD (EOR)
4. The ODRC (Construction Manager)
5. The Mill
6. The Fabricator
7. The Detailer
8. The Connection Designer
9. The Erector
10. The Erection Engineer
11. Quality Control



85

## 9. The Erector

- “The erector shall be responsible for the means, methods, and safety of erection of the structural steel frame” (Section 1.9)
- Section 7, “Erection,” starts with a list of responsibilities of the ODRC before the erector can begin

Night School 18.5!



Ruby+Associates



86



## Means, Methods, and Safety of Erection

- “Means and methods’ refers to the approach to or manner of construction, including amount of labor, material, and equipment necessary to implement the selected technique adopted by the contractor to perform work. In general, a contractor’s ‘means and methods’ refers to the course of construction undertaken by the contractor.” (American Bar Association, via AISC)
- Erection engineering – helps erector determine his/her ‘approach’ and ‘manner’ and provides stability of the structure during erection.



87

## Tolerances

### Section 7.13

- A major portion of the COSP defines erection tolerances
- These tolerances are coordinated with fabrication tolerances (Section 6.4), with other trades (concrete, façade, etc.) and with design practices
  - Direct analysis notional load  $0.002Y$  comes directly from H/500 maximum out of plumbness of the constructed structure
- These tolerances haven’t changed significantly since 1959
  - The owner/EOR/ODRC shouldn’t try to change them arbitrarily
  - Architecturally Exposed Structural Steel (AESS) may be specified (in accordance with COSP Section 10), but this can add project cost



88



## Tolerances

- Written tolerance descriptions summarized graphically in commentary
- Column location summary chart (Fig C-7.5)

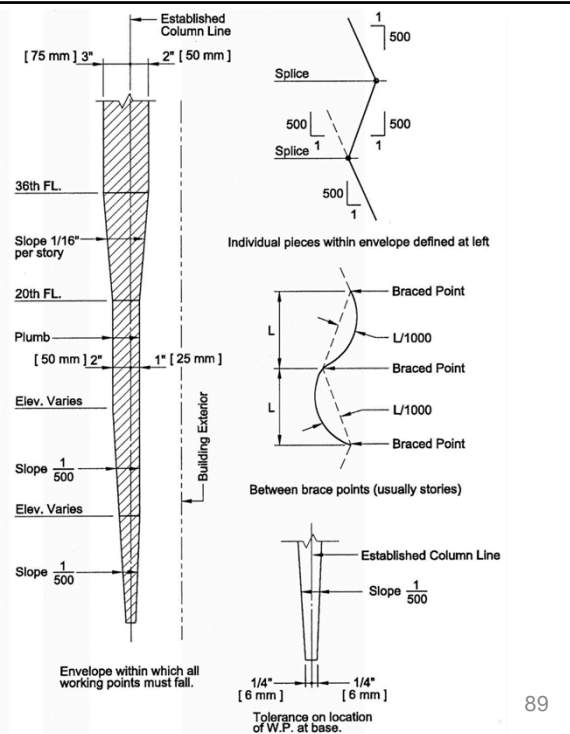

89

## Anchor Bolt Tolerances

## Section 7.5.1

- As noted, ODRC responsible for setting anchor bolts
- Tolerances provided in 7.5.1
- Coordinated with recommended base plate hole sizes in AISC Steel Construction Manual

(b) The horizontal variation in location from the specified position of each *anchor rod* centerline at any location along its projection above the concrete shall be equal to or less than the dimensions given for the *anchor rod* diameters listed as follows:

Anchor Rod Diameter, in. (mm)	Horizontal Variation, in. (mm)
3/4 and 7/8 (19 and 22)	1/4 (6)
1, 1 1/4, 1 1/2 (25, 31, 38)	3/8 (10)
1 3/4, 2, 2 1/2 (44, 50, 63)	1/2 (13)



**Table 14-2  
Recommended Sizes for Washers and  
Anchor Rod Holes in Base Plates**

Anchor Rod Diameter	Hole Diameter	Washer Size	Min. Washer Thickness	Anchor Rod Diameter	Hole Diameter	Washer Size	Min. Washer Thickness
in.	in.	in.	in.	in.	in.	in.	in.
3/4	1 1/16	2	1/4	1 1/2	2 1/8	4	1/2
7/8	1 7/16	2 1/2	5/16	1 3/4	2 3/8	4 1/2	5/8
1	1 5/8	3	3/8	2	3 1/4	5	3/4
1 1/4	2 1/8	3 1/2	1/2	2 1/2	3 3/4	5 1/2	7/8

Notes: 1. Hole sizes provided are based on anchor rod size and correlate with A317 (A317, 2010).  
2. Circular or square washers meeting the washer size are acceptable.  
3. Clearance must be considered when choosing an appropriate anchor rod hole location, noting effects such as the position of the rod in the hole with respect to the column, weld size, and other interferences.  
4. ASTM F844 washers are permitted instead of plate washers when hole clearances are limited to 1/16 in. for rod diameters up to 1 in., 1/8 in. for rod diameters over 1 in. up to 2 in., and 1 in. for rod diameters over 2 in. This exception should not be used unless the general contractor has agreed to meet smaller tolerances for anchor rod placement than those permitted in ACI 117.

90



## Correction of Errors

Section 7.14  
Night School 18.7!

- “Moderate amounts of reaming, grinding, welding, or cutting, and the drawing of elements into line with drift pins, shall be considered to be normal erection operations.”

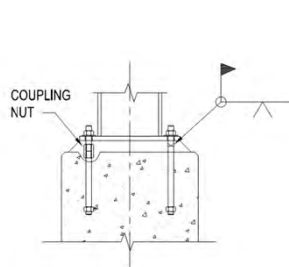

Fig. 7-4. Typical anchor rod extension.

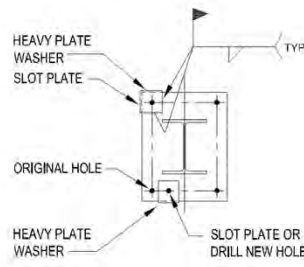

Fig. 7-7. Anchor rod correction—severe mislocation.



DESIGN GUIDE 23 / CONSTRUCTABILITY OF STRUCTURAL STEEL BUILDINGS / 43

91



Courtesy of Williams Enterprises

92



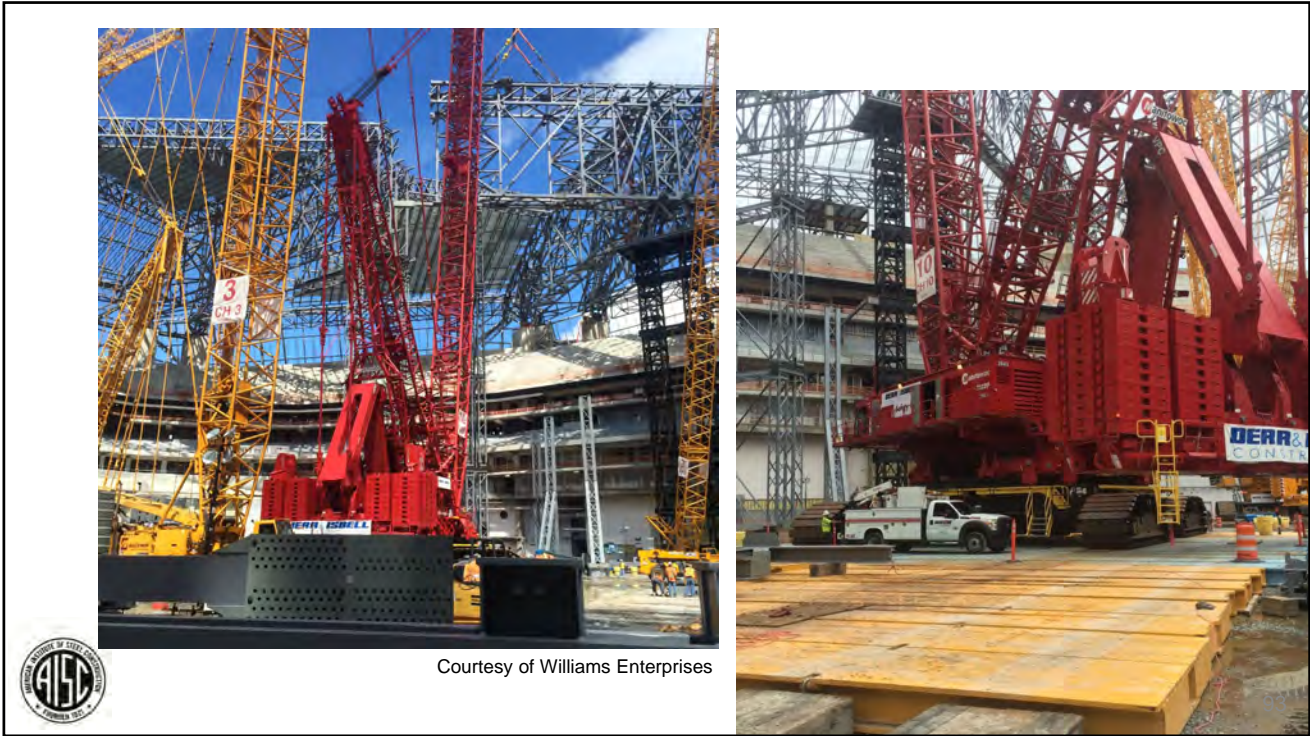

94



## Outline

1. The Team
2. The Owner/Architect
3. The ODRD (EOR)
4. The ODRC (Construction Manager)
5. The Mill
6. The Fabricator
7. The Detailer
8. The Connection Designer
9. The Erector
10. The Erection Engineer
11. Quality Control



95

## 10. The Erection Engineer

Night School 18.6!

- EOR responsible for the structural adequacy and code compliance of the completed structure, but how does it get built?
- Erection Engineering provides an analysis of the structure at various stages of construction to ensure an adequate load path is provided at all times.
- Usually hired by erector, but may be retained by ODRC to prepare erection plan so all erectors have a consistent baseline for bidding.



96



## Lateral Force Resisting System

## Section 7.10

- EOR shall identify:
  - a) “The LFRS and connecting diaphragm elements that provide for lateral strength and stability in the completed structure”
  - b) “Any special erection conditions...such as the use of shores, jacks, or loads that must be adjusted...to set or maintain camber, position within specified tolerances, or prestress.” (7.10.1)
- ODRC shall identify installation schedule for non-steel elements of the LFRS and connecting diaphragm – prior to bidding
  - E.g. erector may need to leave temporary bracing in place until concrete shear walls have reached sufficient strength.



97

## Bracing Provided by Erector

## Section 7.10.3

- “...the erector shall determine, furnish and install all temporary supports, such as temporary guys, beams, falsework, cribbing or other elements required for the erection operation. These temporary supports shall be sufficient to secure the bare structural steel framing or any portion thereof against loads that are likely to be encountered during erection, including those due to wind and those that result from erection operations.  
“The erector need not consider loads during erection that result from the performance of work by, or the acts of, others, except as specifically identified by the owner’s designated representatives for design and construction, nor those that are unpredictable, such as loads due to hurricane, tornado, earthquake, explosion or collision.  
“Temporary supports that are required during or after the erection of the structural steel frame for the support of loads caused by non-structural steel elements, including cladding, interior partitions and other such elements that will induce or transmit loads to the structural steel frame during or after erection, shall be the responsibility of others.”



98



## Bracing Provided by Erector

## Section 7.10.3

- “...the erector shall determine, furnish and install all temporary supports, such as temporary guys, beams, falsework, cribbing or other elements required for the erection operation. These temporary supports shall be sufficient to secure the bare structural steel framing or any portion thereof against loads that are likely to be encountered during erection, including those due to wind and those that result from erection operations.

“The erector need not consider loads during erection that result from the performance of work by, or the acts of, others, except as specifically identified by the owner’s designated representatives for design and construction, nor those that are unpredictable, such as loads due to hurricane, tornado, earthquake, explosion or collision.

“Temporary supports that are required during or after the erection of the structural steel frame for the support of loads caused by non-structural steel elements, including cladding, interior partitions and other such elements that will induce or transmit loads to the structural steel frame during or after erection, shall be the responsibility of others.”



99

## Bracing Provided by Erector

## Section 7.10.3

- “... the erector shall determine, furnish and install all temporary supports, such as temporary guys, beams, falsework, cribbing or other elements required for the erection operation. These temporary supports shall be sufficient to secure the bare structural steel framing or any portion thereof against loads that are likely to be encountered during erection, including those due to wind and those that result from erection operations.

“The erector need not consider loads during erection that result from the performance of work by, or the acts of, others, except as specifically identified by the owner’s designated representatives for design and construction, nor those that are unpredictable, such as loads due to hurricane, tornado, earthquake, explosion or collision.

“Temporary supports that are required during or after the erection of the structural steel frame for the support of loads caused by non-structural steel elements, including cladding, interior partitions and other such elements that will induce or transmit loads to the structural steel frame during or after erection, shall be the responsibility of others.”



100



## Bracing Provided by Erector

## Section 7.10.3

- “... the erector shall determine, furnish and install all temporary supports, such as temporary guys, beams, falsework, cribbing or other elements required for the erection operation. These temporary supports shall be sufficient to secure the bare structural steel framing or any portion thereof against loads that are likely to be encountered during erection, including those due to wind and those that result from erection operations.

“The erector need not consider loads during erection that result from the performance of work by, or the acts of, others, except as specifically identified by the owner’s designated representatives for design and construction, nor those that are unpredictable, such as loads due to hurricane, tornado, earthquake, explosion or collision.

“Temporary supports that are required during or after the erection of the structural steel frame for the support of loads caused by non-structural steel elements, including cladding, interior partitions and other such elements that will induce or transmit loads to the structural steel frame during or after erection, shall be the responsibility of others.”



101

## Bracing Provided by Erector

## Section 7.10.3

- “... the erector shall determine, furnish and install all temporary supports, such as temporary guys, beams, falsework, cribbing or other elements required for the erection operation. These temporary supports shall be sufficient to secure the bare structural steel framing or any portion thereof against loads that are likely to be encountered during erection, including those due to wind and those that result from erection operations.

“The erector need not consider loads during erection that result from the performance of work by, or the acts of, others, except as specifically identified by the owner’s designated representatives for design and construction, nor those that are unpredictable, such as loads due to hurricane, tornado, earthquake, explosion or collision.

“Temporary supports that are required during or after the erection of the structural steel frame for the support of loads caused by non-structural steel elements, including cladding, interior partitions and other such elements that will induce or transmit loads to the structural steel frame during or after erection, shall be the responsibility of others.”



102



## Loads

ASCE7, ASCE37

- Other than gravity load, mainly concerned about wind (ice?)
- Per ASCE37-14 (6.2.1), reduce design wind speed by a factor for project duration to adjust for risk
- 115mph \* 0.8 → 64% of EOR's design wind pressure
- However! Wind load collected by the open structure can be much higher than wind on the final enclosed building
  - Shape Factor,  $C_f$
  - Shielding

**6.2.1 Design Wind Speed** The design wind speed shall be taken as the following factor times the basic wind speed in ASCE/SEI 7-10, except as required in Section 6.2.1.1.1.

Construction Period	Factor
Less than six weeks	0.75
From six weeks to one year	0.8
From one to two years	0.85
From two to five years	0.9

Other Structures		All Heights
Figure 29.5-2	Force Coefficients, $C_f$	Open Signs & Lattice Frameworks



103

## Hurricane Loads

ASCE37-14 6.2.1.1.1

- Per COSP, hurricane loads not required to be considered
- ASCE37 provides wind reduction outside hurricane season, but July through October allows a 115 mph wind speed even near the coast “provided additional bracing is prepared in advance and applied in time before the onset of an announced hurricane.”
- Hurricane contingency plan can be very costly. Communications with erector, ODR, and owner are crucial at the beginning of the project (not when the wind picks up!)

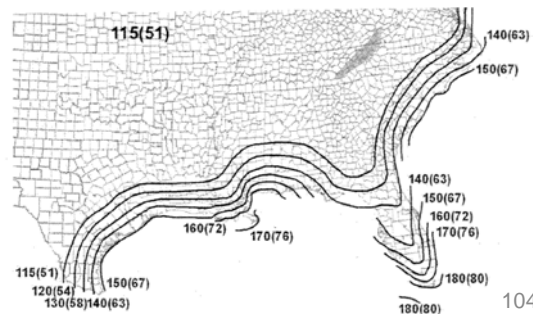

104



## Erection Engineering

- Structure stability – analysis of partially completed structure at each stage of the procedure
- Element stability – analysis of installation of a major element of the structure (truss, subassembled module, cantilever)
- Staged construction – accumulation of dead load stresses that are “locked in” as portions of structure are added



105

## Structure Stability (“Erection Staging”)

- Each stage of erection is a separate analysis
- Load path may be much different than final design
- Temporary bracing provided (usually wire rope) until enough structure is complete to handle the load
- Erector usually wants to know how far ahead of steel deck erection can proceed

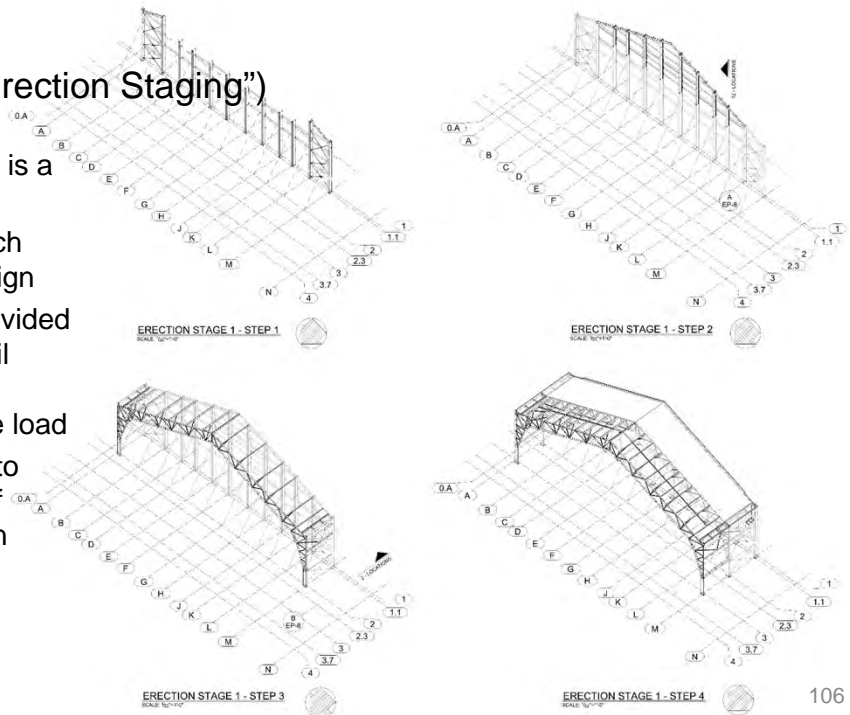

106



### Structure Stability (“Erection Staging”)

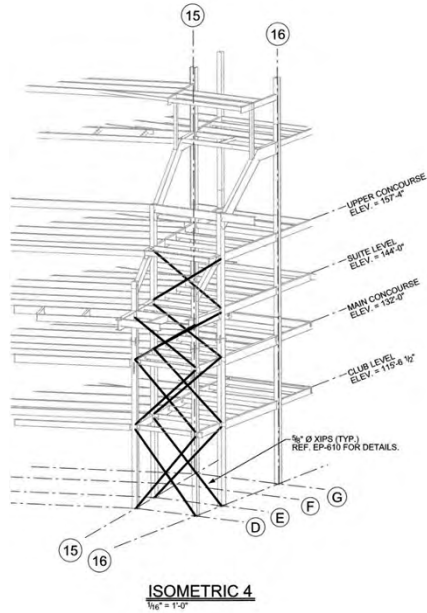

### Element stability

- Analysis of truss or girder under the hook, review of stability before releasing crane

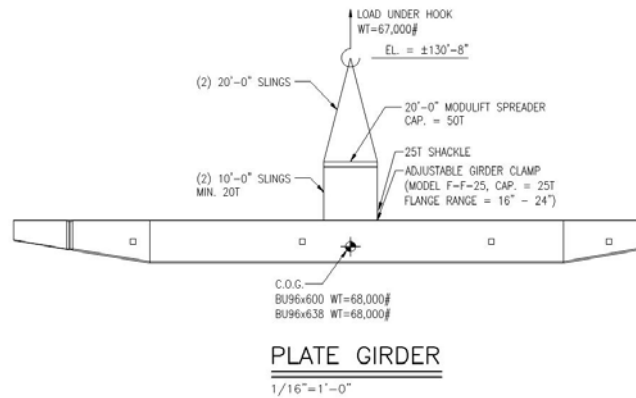
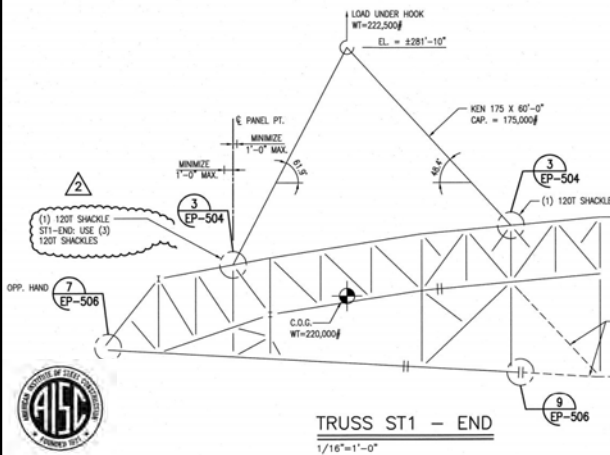

## Staged Construction Analysis

- Highly indeterminate buildings, multiple load paths
- Especially on cable supported structures
- Construction or cable tensioning sequence can greatly affect stresses within the structure



## Outline

1. The Team
2. The Owner/Architect
3. The ODRD (EOR)
4. The ODRC (Construction Manager)
5. The Mill
6. The Fabricator
7. The Detailer
8. The Connection Designer
9. The Erector
10. The Erection Engineer
11. Quality Control



110



# 11. Quality Control

Section 8.1  
Night School 18.8!

- Fabricator (8.1.1) and Erector (8.1.2) shall maintain a quality control program to ensure work is in conformance with COSP, AISC360 “Specification,” and contract documents.
- AISC Specification Chapter N “...addresses the minimum requirements for quality control, quality assurance and nondestructive testing...” (Chapter N Scope)



111

## Specification Chapter N

- Provides guidance for steel inspection, quality program for *all* fabricators & erectors
- New chapter in 2010, but not necessarily new requirements—pulls together all of the quality requirements necessary for steel construction in one place.
- Best part: EOR just has to specify AISC360 and COSP to ensure consistent quality program is required.



Courtesy of Williams Enterprises

112



## QC vs. QA?

- Per ISO9000 (Section 3.2.10 and 11)
  - QC: “A part of quality management focused on fulfilling quality requirements”
  - QA: “part of quality management focused on providing confidence that quality requirements will be fulfilled”



113

## QC vs. QA

- ~~• Per ISO9000 (Section 3.2.10 and 11)~~
  - ~~– QC: “A part of quality management focused on fulfilling quality requirements”~~
  - ~~– QA: “part of quality management focused on providing confidence that quality requirements will be fulfilled”~~
- Per Chapter N1:
  - “Quality Control...shall be provided by **fabricator** and **erector**.”
  - “Quality Assurance...shall be provided by **others** when required by the authority having jurisdiction (AHJ), applicable building code, purchaser, owner, or engineer of record (EOR).”
- Coordinated QC & QA is permitted
  - If approved by EOR or AHJ, QA inspector can rely on QC inspector for overlapping tasks



114



### Observe vs. Perform

- Observe (O): Inspector shall observe these items on a random basis
- Perform (P): Tasks shall be performed for each welded joint/bolted connection
- Similar to IBC “Continuous vs. Periodic” for special inspections
  - IBC only provides tables for joists, concrete, soils, and foundations



TABLE 1705.3  
REQUIRED SPECIAL INSPECTIONS AND TESTS OF CONCRETE CONSTRUCTION

TYPE	CONTINUOUS SPECIAL INSPECTION	PERIODIC SPECIAL INSPECTION	REFERENCED STANDARD <sup>1</sup>	IBC REFERENCE
1. Inspect reinforcement, including prestressing tendons, and verify placement.	—	X	ACI 318 Ch. 20, 25.2, 25.3, 26.6.1-26.6.3	1908.4
2. Reinforcing bar welding: a. Verify weldability of reinforcing bars other than ASTM A706; b. Inspect single-pass fillet welds, maximum $7/16$ " <sup>2</sup> ; and c. Inspect all other welds.	—	X	AWS D1.4 ACI 318: 26.6.4	—
3. Inspect anchors cast in concrete.	—	X	ACI 318: 17.8.2	—
4. Inspect anchors post-installed in hardened concrete members: <sup>3</sup> a. Adhesive anchors installed in horizontally or upwardly inclined orientations to resist sustained tensile loads. b. Mechanical anchors and adhesive anchors not defined in 4.a.	X	—	ACI 318: 17.8.2.4	—
5. Verify use of required design mix.	—	X	ACI 318: Ch. 19, 26.4.3, 26.4.4	1904.1, 1904.2, 1908.2, 1908.3
6. Prior to concrete placement, fabricate speci-	—	—	ACI 318: 17.8.2	—

115

### Inspection requirements

- N5.4 – Welding
- N5.5 – NDT
- N5.6 - Bolting

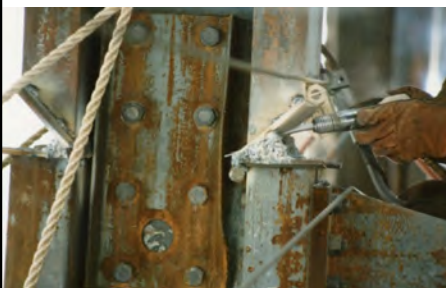

Courtesy of Williams Enterprises



**TABLE N5.6-1  
Inspection Tasks Prior to Bolting**

Inspection Tasks Prior to Bolting	QC	QA
Manufacturer's certifications available for fastener materials	O	P

**TABLE N5.4-1  
Inspection Tasks Prior to Welding**

Inspection Tasks Prior to Welding	QC	QA
Welding procedure specifications (WPSs) available	P	P
Manufacturer certifications for welding consumables available	P	P
Material identification (type/grade)	O	O
Welder identification system <sup>1</sup>	O	O
Fit-up of groove welds (including joint geometry) <ul style="list-style-type: none"> <li>• Joint preparation</li> <li>• Dimensions (alignment, root opening, root face, bevel)</li> <li>• Cleanliness (condition of steel surfaces)</li> <li>• Tackling (tack weld quality and location)</li> </ul>	O	O

O	O
O	O
O	O
O	O
O	O
O	O
O	O
O	O
O	O
O	O

116



# Conclusion

## Night School 18

- 18.1 **Introduction** to the Steel Construction Process Oct. 15
- 18.2 The **Manufacturing** of Structural Steel Shapes Oct. 22
- 18.3 A Virtual, Detailed Tour of the **Steel Fabrication** Process Oct. 29
- 18.4 **Connection Design** as the Fabricator's Representative Nov. 5
- 18.5 It Doesn't Get Built Without the **Erector** Nov. 19
- 18.6 **Erection Engineering** – Stability During Construction Nov. 26
- 18.7 **Field Fixes** and Solutions Dec. 3
- 18.8 **Quality Control** and Quality Assurance Dec. 10

ANSI/AISC 303-16  
 An American National Standard

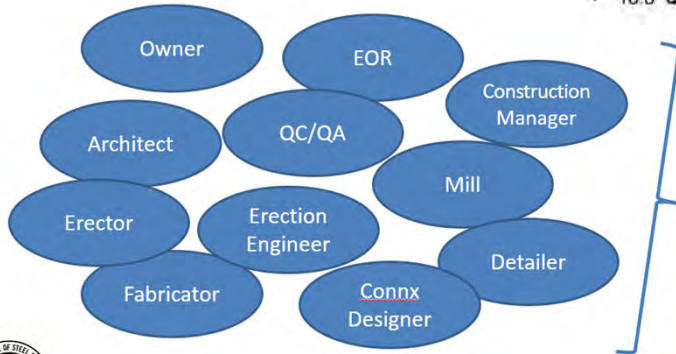

## Code of Standard Practice for Steel Buildings and Bridges

June 15, 2016

Supersedes the Code of Standard Practice for Steel Buildings and Bridges dated April 14, 2010 and all previous versions

Approved by the Committee on the Code of Standard Practice

117



# Night School 18: Steel Construction

From the Mill to Topping Out

Session 1: Introduction to the Steel Construction Process

October 15, 2018

(The Team Behind the Building)

AISC | Questions?



**Smarter.  
 Stronger.  
 Steel.**



## Individual Webinar Registrants

---

### CEU/PDH Certificates

Within 2 business days...

- You will receive an email on how to report attendance from: [registration@aisc.org](mailto:registration@aisc.org).
- Be on the lookout: Check your spam filter! Check your junk folder!
- Completely fill out online form. Don't forget to check the boxes next to each attendee's name!



## Individual Webinar Registrants

---

### CEU/PDH Certificates

Within 2 business days...

- New reporting site (URL will be provided in the forthcoming email).
- Username: Same as AISC website username.
- Password: Same as AISC website password.



## 8-Session Registrants

---

### CEU/PDH Certificates

One certificate will be issued at the conclusion of  
all 8 sessions.



## 8-Session Registrants

---

Access to the quiz: Information for accessing the quiz will be emailed to you by Wednesday. It will contain a link to access the quiz. EMAIL COMES FROM NIGHTSCHOOL@AISC.ORG

Quiz and Attendance records: Posted Tuesday mornings.  
[www.aisc.org/nightschool](http://www.aisc.org/nightschool) - click on Current Course Details.

Reasons for quiz:

- EEU – must take all quizzes and final to receive EEU
- CEUs/PDHS – If you watch a recorded session you must take quiz for CEUs/PDHS.
- REINFORCEMENT – Reinforce what you learned tonight. Get more out of the course.

NOTE: If you attend the live presentation, you do not have to take the quizzes to receive CEUs/PDHS.



## 8-Session Registrants

---

**Access to the recording:** Information for accessing the recording will be emailed to you by this Wednesday. The recording will be available for three weeks. For 8-session registrants only. EMAIL COMES FROM NIGHTSCHOOL@AISC.ORG.

**CEUs/PDHS** – If you watch a recorded session you must take AND PASS the quiz for CEUs/PDHS.



## Night School Resources for 8-session package Registrants

---

Find all your handouts, quizzes and quiz scores, recording access, and attendance information all in one place!



## Night School Resources for 8-session package Registrants

Go to [www.aisc.org](http://www.aisc.org) and sign in.

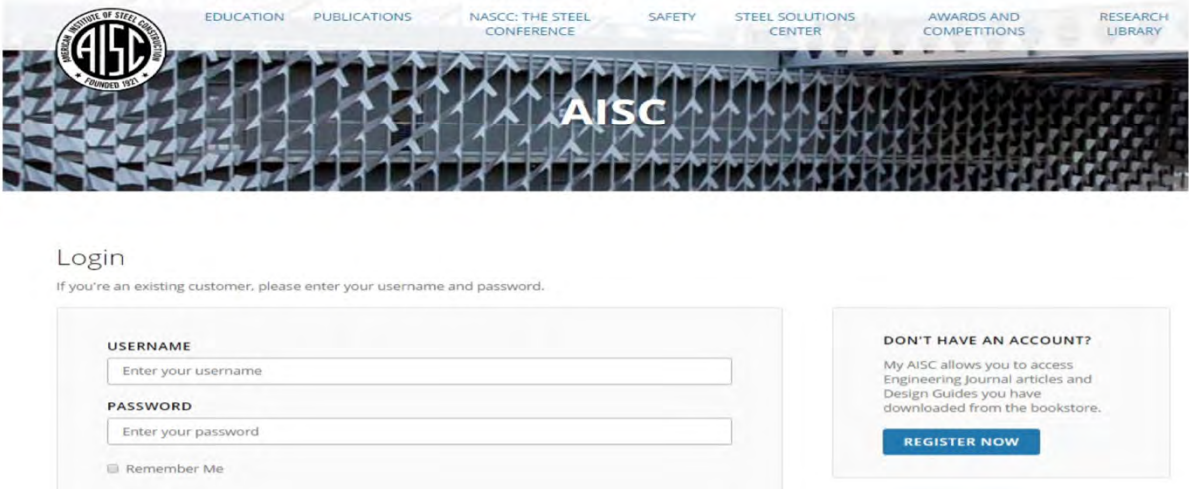

**USERNAME**  
Enter your username

**PASSWORD**  
Enter your password

Remember Me

**DON'T HAVE AN ACCOUNT?**  
My AISC allows you to access Engineering Journal articles and Design Guides you have downloaded from the bookstore.

[REGISTER NOW](#)

## ~~Night School Resources for 8-session~~ package Registrants

Go to [www.aisc.org](http://www.aisc.org) and sign in.

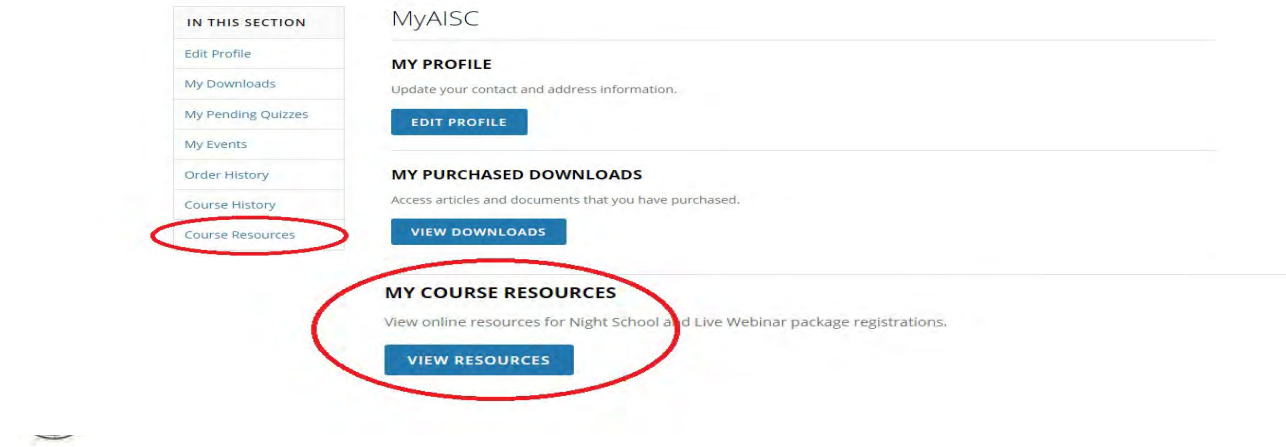

**IN THIS SECTION**

- Edit Profile
- My Downloads
- My Pending Quizzes
- My Events
- Order History
- Course History
- Course Resources

**MyAISC**

**MY PROFILE**  
Update your contact and address information.

[EDIT PROFILE](#)

**MY PURCHASED DOWNLOADS**  
Access articles and documents that you have purchased.

[VIEW DOWNLOADS](#)

**MY COURSE RESOURCES**  
View online resources for Night School and Live Webinar package registrations.

[VIEW RESOURCES](#)



## Night School Resources for 8-session package Registrants



### Night School 13: Design of Industrial Buildings

#### 8-SESSION PACKAGE RESOURCES

Event	Date	Handouts	Video	Quiz	Attendance
NS13 - Design Criteria	1/30/2017 7:00:00 PM	<a href="#">Handouts</a>	<a href="#">View</a> Passcode: NS13DSN	Pass Score: 80	Pending
NS13 - Economic Considerations	2/6/2017 7:00:00 PM	<a href="#">Handouts</a>	Available 02/08/2017 5pm EST	Available 02/08/2017 5pm EST	Pending
NS13 - Lateral Load Systems and Details	2/13/2017 7:00:00 PM	<a href="#">Handouts</a>	Available 02/15/2017 5pm EST	Available 02/15/2017 5pm EST	Pending
NS13 - Preliminary Design Procedures	2/27/2017 7:00:00 PM	<a href="#">Handouts</a>	Available 03/01/2017 5pm EST	Available 03/01/2017 5pm EST	Pending
NS13 - Crane Girder Design and Frame Analysis	3/6/2017 7:00:00 PM	<a href="#">Handouts</a>	Available 03/08/2017 5pm EST	Available 03/08/2017 5pm EST	Pending
NS13 - Frame Member and Connection Design	3/13/2017 7:00:00 PM	<a href="#">Handouts</a>	Available 03/15/2017 5pm EST	Available 03/15/2017 5pm EST	Pending
NS13 - Transfer Crane Girder & Longitudinal Bldg Bracing Dsn	3/27/2017 7:00:00 PM	<a href="#">Handouts</a>	Available 03/29/2017 5pm EST	Available 03/29/2017 5pm EST	Pending
NS13 - Building Envelope and Bracing Design	4/3/2017 7:00:00 PM	<a href="#">Handouts</a>	Available 04/05/2017 5pm EST	Available 04/05/2017 5pm EST	Pending
NS13 - Final Exam	4/10/2017 7:00:00 PM			Available 04/12/2017 5pm EST	

## Night School Resources for 8-session package Registrants

- Weekly “quiz and recording” email.
- Weekly updates of the master Quiz and Attendance record found at [www.aisc.org/nightschool](http://www.aisc.org/nightschool). Scroll down to Quiz and Attendance records.
  - Updated on Tuesday mornings.



## Night School Resources for 8-session package Registrants

- Webinar connection information:
  - Found in your registration confirmation/receipt.
  - Reminder email sent out Monday mornings.
- Link to handouts also found here.



**AISC** | Thank you



**Smarter.  
Stronger.  
Steel.**

