



AISC Night School

Thank you for joining our live webinar today.
We will begin shortly. Please standby.

Thank you.
Need Help?
Call ReadyTalk Support: 800.843.9166



Steel Construction | From the Mill to Topping Out





**Smarter.
Stronger.
Steel.**



Today's audio will be broadcast through the internet.



Alternatively, to hear the audio through the phone, dial 866-519-2796. Passcode: 387037



Today's live webinar will begin shortly.
Please standby.

As a reminder, all lines have been muted. Please type any questions or comments through the Chat feature on the left portion of your screen.

Today's audio will be broadcast through the internet. Alternatively, to hear the audio through the phone, dial 866-519-2796. Passcode: 387037



AISC is a Registered Provider with The American Institute of Architects Continuing Education Systems (AIA/CES). Credit(s) earned on completion of this program will be reported to AIA/CES for AIA members. Certificates of Completion for both AIA members and non-AIA members are available upon request.

This program is registered with AIA/CES for continuing professional education. As such, it does not include content that may be deemed or construed to be an approval or endorsement by the AIA of any material of construction or any method or manner of handling, using, distributing, or dealing in any material or product.

Questions related to specific materials, methods, and services will be addressed at the conclusion of this presentation.





Copyright Materials

This presentation is protected by US and International Copyright laws. Reproduction, distribution, display and use of the presentation without written permission of AISC is prohibited.

© The American Institute of Steel Construction 2018



Session Description

18.1 Introduction to the Steel Construction Process October 15, 2018

All parties involved in the steel construction process play a critical role, from the office (structural design, connection design, and erection engineering), to the plant (steel production and fabrication), to the field (erection and quality assurance). Using the AISC Code of Standard Practice as a framework, this session discusses the team of contributors who are responsible for creating a structural steel building.



Learning Objectives

- Describe the roles and responsibilities of key team members on a structural steel project.
- Describe how understanding and integrating constructability into your building design leads to safe, efficient designs.
- Define the role the AISC Code of Standard Practice has in steel buildings.
- List the different relationship arrangements of team members based on the type of contractual agreement: design-bid-build, design-build, and design-detail.



Night School 18: Steel Construction

From the Mill to Topping Out

Session 1: Introduction to the Steel Construction Process

October 15, 2018

(The Team Behind the Building)



Andrew Twarek, PE, SE
Project Manager
Ruby+Associates, Inc. Structural Engineers
Bingham Farms, MI



About Me

ruby+associates
 STRUCTURAL ENGINEERS

SEAMi
 Structural Engineers Association of Michigan

ROSE-HULMAN
 FIGHTIN' HULLCORPS

CUBS

D

11

Night School 18

- 18.1 **Introduction** to the Steel Construction Process Oct. 15
- 18.2 The **Manufacturing** of Structural Steel Shapes Oct. 22
- 18.3 A Virtual, Detailed Tour of the **Steel Fabrication** Process Oct. 29
- 18.4 **Connection Design** as the Fabricator's Representative Nov. 5
- 18.5 It Doesn't Get Built Without the **Erector** Nov. 19
- 18.6 **Erection Engineering** – Stability During Construction Nov. 26
- 18.7 **Field Fixes** and Solutions Dec. 3
- 18.8 **Quality** Control and Quality Assurance Dec. 10

10

Outline

1. The Team
2. The Owner/Architect
3. The ODRD (EOR)
4. The ODRC (Construction Manager)
5. The Mill
6. The Fabricator
7. The Detailer
8. The Connection Designer
9. The Erector
10. The Erection Engineer
11. Quality Control

11

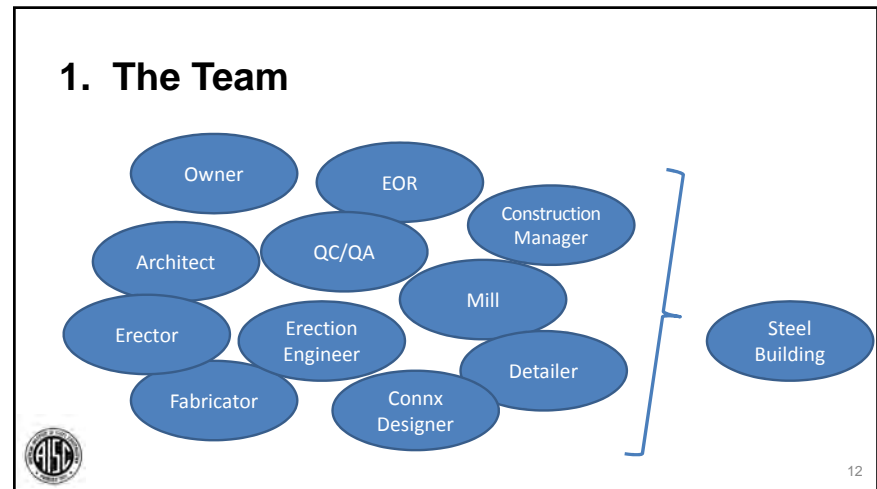

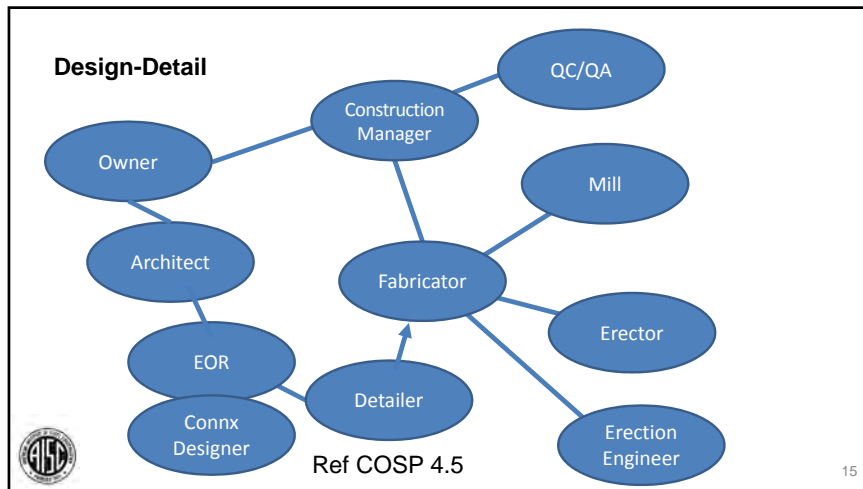
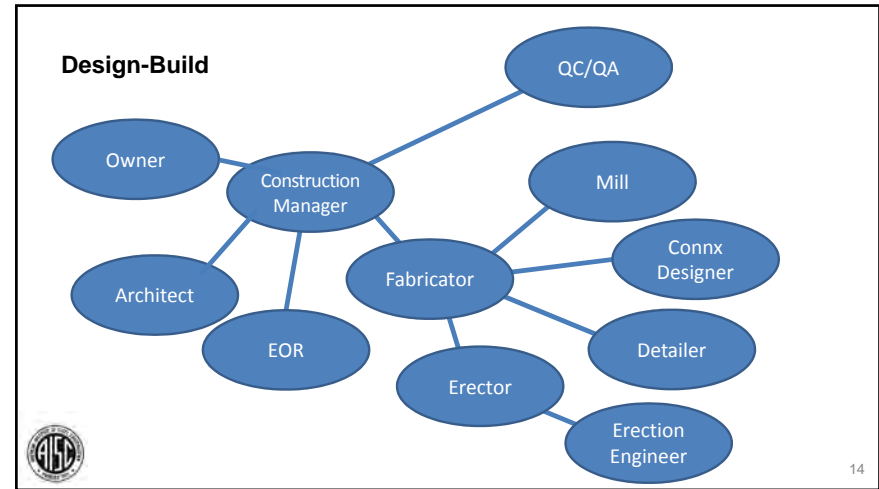
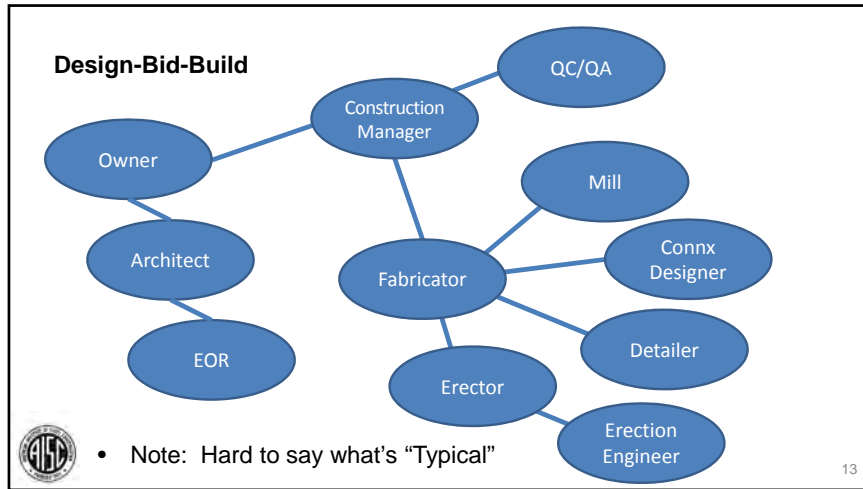

Other Contractual Arrangements

- **Fast Track Projects**
 - Begin construction before design is complete
 - Not atypical on large projects
 - Design may be conservative (i.e. more costly) at front end, but shortens schedule
 - Occupancy = owner revenue
 - COSP 3.6
- **Design-Fab**
 - Fabricator both designs and fabricates
 - Typical for "Metal Building Systems" (Butler, Nucor)

www.nucorbuildingsystems.com



AISC Code of Standard Practice (COSP) ANSI/AISC 303-16
An American National Standard

- Defines "...criteria for the trade practices involved in steel buildings..." (Sec. 1.1)
- Identifies who's responsible for what
- May be modified by contract documents

Code of Standard Practice for Steel Buildings and Bridges

June 15, 2016

Supersedes the Code of Standard Practice for Steel Buildings and Bridges dated April 14, 2010 and all previous versions

Approved by the Committee on the Code of Standard Practice



17

What is Structural Steel? Section 2.1

COSP (or other document) Reference →

- Elements of the structural frame, shown & sized in the structural design documents, essential to support the design loads
- Normally furnished by fabricator
 - Anchor rods
 - Base plates*
 - Beams*
 - Bearing plates*
 - Bracing, if permanent
 - Columns*
 - Connection materials
 - Door frames*
 - Embedded structural steel parts*
 - Floor-opening frames*
 - Girders*
 - Girts*
 - Leveling plates
 - Posts*
 - Purlins*
 - Tie rods*

* "If part of/attached to the structural frame" or "if made from structural shapes or plates"
 Note: See COSP for entire list



18

What is NOT Structural Steel? Section 2.2

- May be furnished by fabricator if contracted to do so

<ul style="list-style-type: none"> • Cables for permanent bracing • Castings • Cold-formed steel products • Expansion joints* • Flagpole support steel • Gage-metal products • Grating • Handrail 	<ul style="list-style-type: none"> • Ladders • Lintels* • Roof screen support frames* • Stairs • Steel deck • Steel (open-web) joists • Toe plates
---	---

* "If not part of/not attached to the structural frame," "if not made from structural shapes/plates"
 Note: See COSP for entire list



19

Outline

1. The Team	6. The Fabricator
2. The Owner/Architect	7. The Detailer
3. The ODRD (EOR)	8. The Connection Designer
4. The ODRC (Construction Manager)	9. The Erector
5. The Mill	10. The Erection Engineer
	11. Quality Control



20



2. The Owner/Architect

Responsibilities include:

- Determine size, configuration, performance criteria for building
- Provide life safety (maximum occupant load, vertical/horizontal circulation, exits, construction fire rating, etc.)
- Finishes (ceiling, floor, wall covering, furniture layouts and selection, door/window schedule)
- Determine contract arrangement
- Pay for building



21

Other Trades

- Civil (earthwork)
- Electrical
- HVAC (heating, ventilating, air conditioning)
- Plumbing

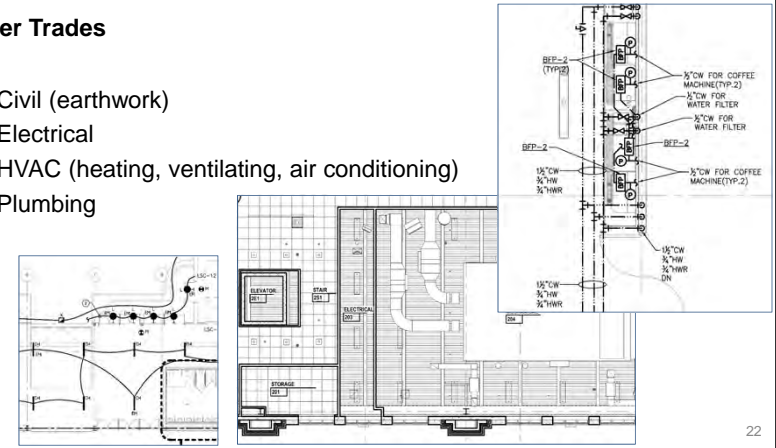

22

Constructability

- Ability to influence the cost and quality of construction over the life of a project
- Cost and schedule impacts of making changes

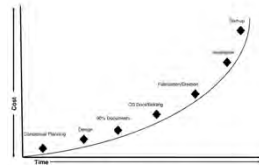

Fig. 1-2. Cost of change over time.



23 Steel Design Guide

Constructability of Structural Steel Buildings



23

Constructability

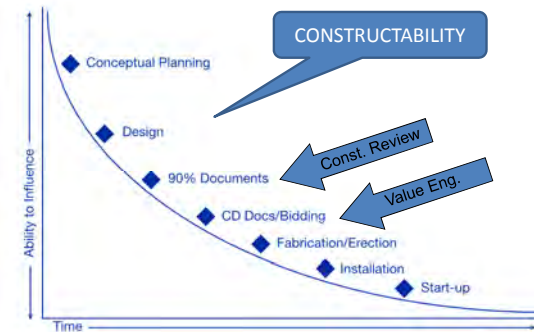

24



Outline

- | | |
|------------------------------------|----------------------------|
| 1. The Team | 6. The Fabricator |
| 2. The Owner/Architect | 7. The Detailer |
| 3. The ODRD (EOR) | 8. The Connection Designer |
| 4. The ODRC (Construction Manager) | 9. The Erector |
| 5. The Mill | 10. The Erection Engineer |
| | 11. Quality Control |



25

3. The ODRD

Owner's Designated Representative for Design

- Engineer of Record (EOR)
- Responsible for structural adequacy of design (Building Code Compliance)
 - ASCE7 "Minimum Design Loads...for Buildings..."
 - AISC 360 "Specification for Structural Steel Buildings"
 - ACI318 "Building Code Requirements for Structural Concrete"
 - MSJC/TMS402 "Building Code Requirements for Masonry Structures"
 - Etc.

Section 3



26

Contract Documents

Section 3.1

- Define responsibility of the parties involved in bidding, fabricating, erecting structural steel

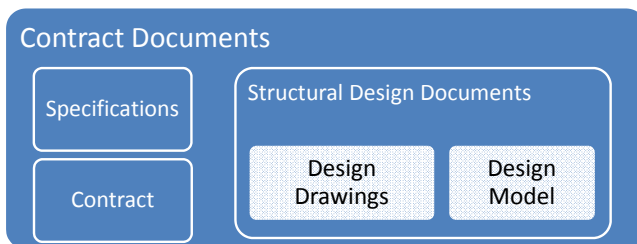

27

Design Documents

- Schematic Design (SD)
 - Rough sketches and analysis to determine project scope, estimated costs
- Design Development (DD)
 - Engineering design, usually issued in sets (50%DD, 75%DD) to coordinate with owner, architect, other trades, as design is firmed up
 - Mill order – sometimes issued prior to CDs so fabricator can begin to source steel directly from mill
- Construction Documents (CD) – Bid Set
 - Design should be complete with all information fabricator and erector need to provide accurate and complete bids to owner
- Revisions



28



Design Documents Section 3.1

- Basic Requirements (bare minimum)
 - a) The size, section, material grade and location of all members.
 - b) All geometry and working points necessary for layout.
 - c) Floor elevations.
 - d) Column centers and offsets.
 - e) The camber requirements for members.
 - f) Preset elevation requirements, if any, at free ends of cantilevered members relative to their fixed-end elevations.
 - g) Joining requirements between elements of built-up members.
 - h) Information required by AISC341 Section A4.
- Special limitations, fab/erect tolerances, AESS* (Section 10)



29

Design Documents Section 3.1

- Connection Design Information (3.1.1)
 - Three options (More later!)
- Lateral Force Resisting System (7.10.1)
 - Must define the LFRS and connecting diaphragm elements (both steel and nonsteel) so stability of the structure is clearly understood.
- Non-Structural Steel Elements in LFRS (3.1.4)
 - "When the [completed] structural steel frame...requires interaction with non-structural steel elements (see Section 2) [sic] for strength and/or stability, those non-structural steel elements shall be identified in the contract documents as required in Section 7.10."

All lateral force resistance and stability of the building in the completed structure is provided exclusively by cast-in-place reinforced concrete shear walls in the building core and stairwells (see plan sheets for locations). These walls provide all lateral force resistance in each orthogonal building direction. The composite metal deck and concrete floors serve as horizontal diaphragms that distribute the lateral wind and seismic forces horizontally to the concrete shear walls. The concrete shear walls carry the applied lateral loads to the building foundation.



30

Design Documents Section 3

- Criteria for Specialty Structural Engineer (SSE)
 - Load, deflection, performance requirements for "buy out" items such as:
 - Joists
 - Proprietary Connections
 - Structural Castings
 - Manufactured Moment Connections
 - Buckling-Restrained Braces

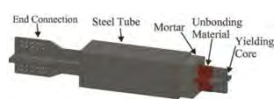
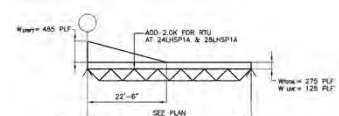
Example joist special loading diagram



31

Outline

1. The Team	6. The Fabricator
2. The Owner/Architect	7. The Detailer
3. The ODRD (EOR)	8. The Connection Designer
4. The ODRC (Construction Manager)	9. The Erector
5. The Mill	10. The Erection Engineer
	11. Quality Control



32



4. The ODRC

Owner's Designated Representative for Construction

- General Contractor (GC)
- Construction Manager (CM)
- Responsible for "...the overall construction of the project, including its planning, quality, and completion." (Glossary)
- Maintains latest contract documents and other information flow and Requests for Information (RFI's) between parties
- Manages construction budget



33

ODRC

- Provides material access and workable jobsite conditions
- Also responsible for prepwork:
 - Foundations,
 - Lines & benchmarks
 - Anchor bolts installation
 - Leveling plates/loose base plates (not requiring a crane)
- Column base grouting

Section 7



Photo by Ben Hur, Inc.

34

Outline

- | | |
|------------------------------------|----------------------------|
| 1. The Team | 6. The Fabricator |
| 2. The Owner/Architect | 7. The Detailer |
| 3. The ODRD (EOR) | 8. The Connection Designer |
| 4. The ODRC (Construction Manager) | 9. The Erector |
| 5. The Mill | 10. The Erection Engineer |
| | 11. Quality Control |



35

5. The Mill

- Responsible for transforming raw materials into new steel, controlling chemistry, creating (rolling) shapes suitable for steel construction
- Uses iron (produced from ore in a blast furnace) and/or scrap steel
- Iron – more than 2% carbon
- Steel – 0.05% - 1% carbon (structural typically less than 0.25%)



Photo by Rio Grand Guardian



36



Steel Production Process

- Electric Arc Furnace –
 - “Minimill” – smaller batches made using mostly scrap steel
 - Virtually all of US structural shape production
 - Much more adaptable to vary production
 - Can be located near markets

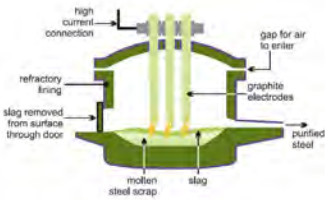

www.sfsa.org/sc3/downloads/E14_Steel_Castings_in_Architecture.pdf (NASCC 2017)

Photo by Steel Dynamics

Steel Recycles!

- Structural steel production in US averages 93% recycled scrap steel
- At the end of a building’s life, 98% of all structural steel is recycled into new steel products
 (statistics by AISC)

Recycled Content – LEED 2009 MR 4; LEED v4 MR Credit: Sourcing of Raw Material

2017 Recycled Steel Content of Nucor Products (% by Total Weight)	
Product Group	Average Recycled Content
Nucor Bar Products	96.1%
Nucor Engineered Bar Products	86.5%
Nucor Beam Products	80.7%
Nucor Plate Products	63.1%
Nucor Sheet Products	58.9%
Nucor Castrip®	86.0%
Total Nucor Steel Combined	72.6%
Vulcraft Structural Products	96.1%
Vulcraft / Vero Decking	58.9%
Nucor Grating / Fisher-Ludlow Grating	96.1%
Nucor Building Group	72.6%
Harris Rebar	96.1%
Nucor Fastener Products	96.1%
Nucor Wire Products	96.1%
Nucor Cold Finish	86.5%



38

Steel Production Process Flow Sheet

Courtesy of Nucor Yamato

Night School 18.2!

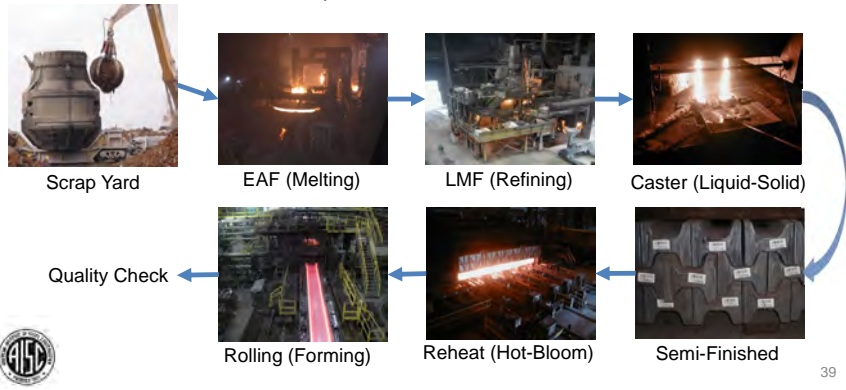

39

Steel Production Process

- Rolling a W14x176



Photos courtesy of Nucor



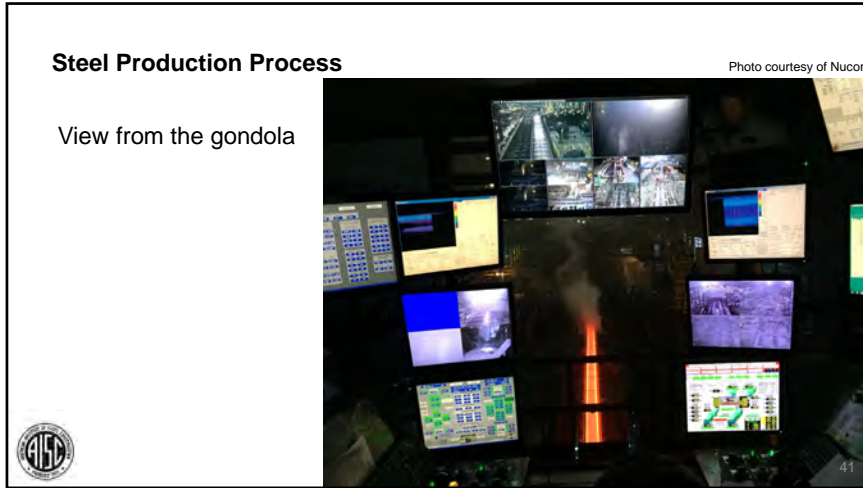

Steel Chemistry (A992 maximums, e.g.)

- Carbon 0.23% Fundamental ingredient in steel. Increases yield strength, hardness
- Silicon 0.4% Deoxidation, increases tensile strength
- Vanadium 0.15% Finer grains, less weldability, better wear resist
- Sulfur 0.045% Can cause cracking
- Manganese ~1% Neutralizes sulfur, deoxidation
- Nickel 0.45% Reduce brittleness, increase toughness
- Chromium 0.35% Hardening, corrosion resistance (high amounts)
- Molybdenum 0.15% Hardening, increase tensile strength

Preferred Grades

- Wide Flange – ASTM A992
- HSS – ASTM A500 Gr. C or A1085
- A36 still default steel for:
 - Standard and Misc. I shapes
 - Channels and MCs
 - Angles
- Plate
 - ASTM A36 or ASTM A572 Gr. 50
 - Often no surcharge for 50 ksi plate
 - No reason not to take advantage of it!

Table 2-4
Applicable ASTM Specifications for Various Structural Shapes

Steel Type	ASTM Designation	F _y Yield Stress* (ksi)	F _t Tensile Stress* (ksi)	Applicable Shape Series												
				W	M	S	HP	C	MC	L	Incl.	HSS Round	Pipe			
A36	A36	36	58-80													
	A36 Gr. B	35	60													
	A36 Gr. C	42	58													
A500	A500 Gr. B	46	58													
	A500 Gr. C	46	62													
	A500 Gr. A	50	62													
A572	A572 Gr. A	36	58													
	A572 Gr. B	50	70													
	A572 Gr. C	50	70													

Table 2-5
Applicable ASTM Specifications for Plates and Bars

Steel Type	ASTM Designation	F _y Yield Stress* (ksi)	F _t Tensile Stress* (ksi)	Plates and Bars, in.												
				over 1/2 to 1.25	over 1.25 to 1.5	over 1.5 to 2	over 2 to 2.5	over 2.5 to 4	over 4 to 5	over 5 to 8	over 8					
Carbon	A36	36	58-80													
	A36 Gr. C	30	55-75													
	A36 Gr. D	30	60-80													
	A36 Gr. 50	50	65-100													
	A36 Gr. 55	55	70-100													
A572	A572 Gr. 30	30	58-80													
	A572 Gr. 42	42	60													
	A572 Gr. 50	50	65													
A572	A572 Gr. 55	55	70													
	A572 Gr. 55	55	70													

Preferred Grades

Bolts

- Group A - 120ksi
 - A325, A325M, F1852
- Group B - 150ksi
 - A490, A490M, F2280
- Group C - 200ksi
 - “XTB”, ASTM F3043 and F3111
- ASTM F3125 Grade A325, e.g.

Table 2-6
Applicable ASTM Specifications for Various Types of Structural Fasteners

ASTM Designation	F _y Min. Yield Stress (ksi)	F _t Tensile Stress* (ksi)	Diameter Range (in.)	Bolts		Washers		Anchor Rods	
				High-Strength	Conventional	Hardened	Plain	Threaded Rods	Headed
Gr. A325	—	120	0.5 to 1.5						
Gr. F1852	—	120	0.5 to 1.5						
Gr. A490	—	150	0.5 to 1.5						
Gr. F2280	—	150	0.5 to 1.5						
F3111	—	200	1 to 1.25 incl.						
F3043	—	200	1 to 1.25 incl.						
A194 Gr. 2H	—	—	0.25 to 4						
A193	—	—	0.25 to 4						
F438	—	—	0.25 to 6"						
F844	—	—	any						
F958	—	—	0.5 to 1.5						
A36	36	58-80	to 19"						
Gr. 30	30	38-60	0.25 to 4						
Gr. 35	35	75-95	0.25 to 4						
Gr. 105	105	125-150	0.25 to 3						



Steel Availability

- AISC website lookup
- More producers = more common
- May still need to check rolling schedule

AISC MEMBERS					
W Shapes	Grade	Gerdau AmeriSteel	Nucor-Berkeley	Nucor-Yamato Steel Co.	Steel Dynamics
4 x 13 x 4	A992	✓	✓		✓
4 x 13 x 4	A709				✓
5 x 16 x 5	A709				✓
5 x 16 x 5	A992		✓		✓
5 x 19 x 5	A992		✓		✓
5 x 19 x 5	A709				✓
6 x 8.5 x 4	A709				✓
6 x 8.5 x 4	A992	✓	✓		✓
6 x 9 x 4	A992	✓	✓		✓
6 x 9 x 4	A709				✓
6 x 12 x 4	A709				✓
6 x 12 x 4	A992	✓	✓		✓



Rolling Schedules / Advanced Bill of Materials (ABM)

- Shapes only rolled every several weeks
- To get “first choice” of mill products, fabricator must purchase via mill order. Important to get accurate ABM from fabricator. EOR must lock member sizes, lengths.

Nucor-Yamato Proposed Roll/Close Schedule * ISO 9001:2015 Registered * October 10, 2018
 Inquire items are followed immediately by the last order date of the Book area if available. Highlighted items will close in the next week!

Week Beginning	7-Oct	14-Oct	21-Oct	28-Oct	4-Nov	11-Nov	18-Nov	25-Nov	Proposed next roll date
Wide Flange Sections									
W6x15x230-335								47	107-05 Wks
W6x15x199-293								47	107-05 Wks
W6x15x149-252			42	C				47	102-10 Wks
W6x17x487-652								48	107-05 Wks
W6x18.5x231-441			42	C				48	102-10 Wks
W6x18.5x195-296			42	C				48	102-10 Wks
W6x18.5x159-257			42	C				48	102-10 Wks
W6x18.5x118-189			42	C				48	102-10 Wks
W6x18.5x93-133			42	C				48	102-10 Wks
W6x18.5x68-118			42	C				48	102-10 Wks
W6x18.5x48-88			42	C				48	102-10 Wks
W6x18.5x41-79			42	C				48	102-10 Wks
W6x18.5x34-59			42	C				48	102-10 Wks
W6x18.5x32			42	C				48	102-10 Wks
W6x18.5x27			42	C				48	102-10 Wks

Legend: I = Inquire, C = Close, PS = Planned Stock, SA = Subject to Annotation, E = Expedite, G = Closed



Service Centers

- Steel not purchased via mill order may come from fabricator stock or steel service center
- Expensive to keep stockpile of steel in fabricator's yard
- Service center can order in bulk, pass along savings (along with warehousing, handling costs)
- Service center may sell steel marked, cut to length, ready for fab



<https://www.rverson.com/services/what-we-do>



Outline

- The Team
- The Owner/Architect
- The ODRD (EOR)
- The ODRC (Construction Manager)
- The Mill
- The Fabricator
- The Detailer
- The Connection Designer
- The Erector
- The Erection Engineer
- Quality Control



6. The Fabricator

Section 6

- Turns steel stock into assemblies for site installation
- Main point of contact for steel supply per COSP
 - Sources steel, as well as other “buy out” items like bolts
 - Usually holds contract for connection designer and detailer
 - Must sequence work with erector to avoid storing too much material (especially at a busy jobsite)



49

Fabrication Process

Night School 18.3!

- Quick overview of fabrication shop stations
- Shops vary in level of complexity and automation – everywhere between fully manual and fully computer-controlled
- Photos courtesy of Voortman and Cianbro Corporation



50

Cutting – Bandsaw

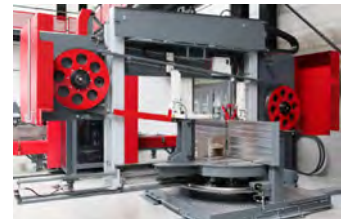

Holes – Drilling

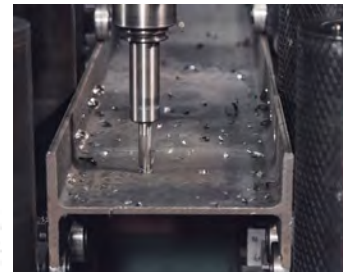

52



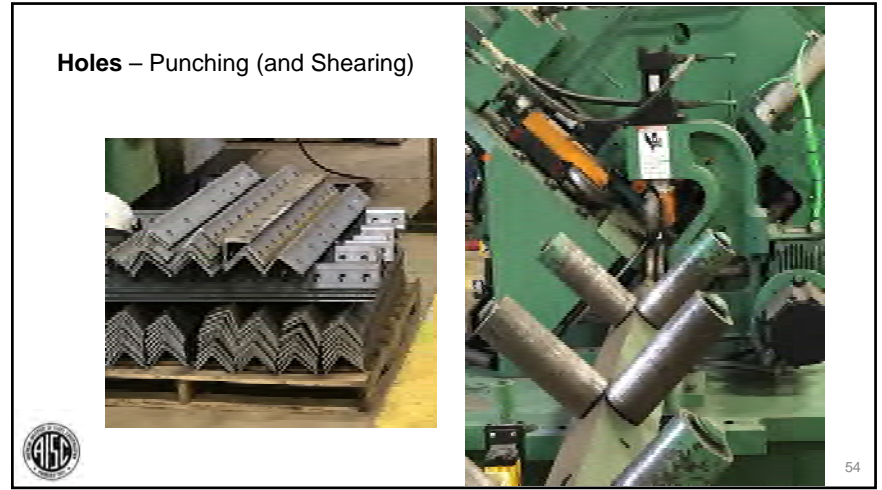
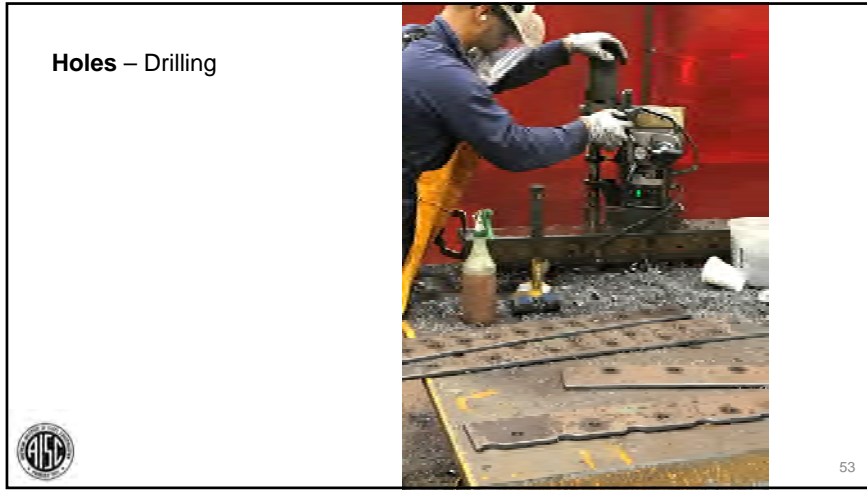

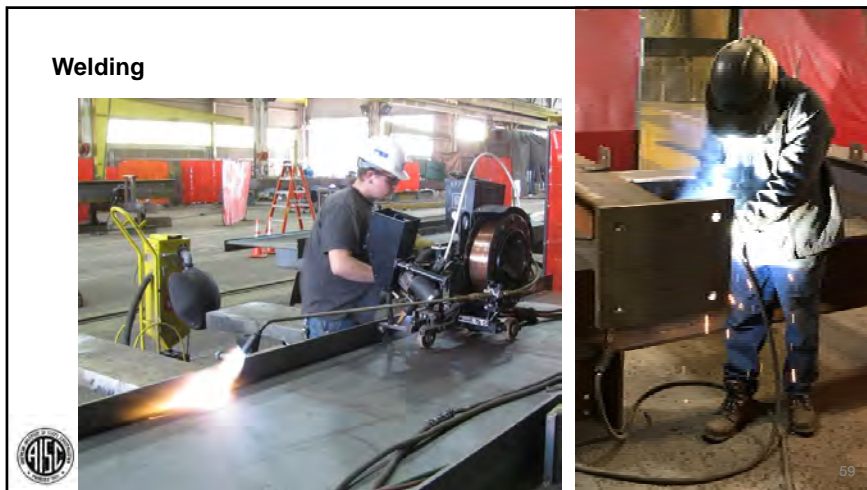
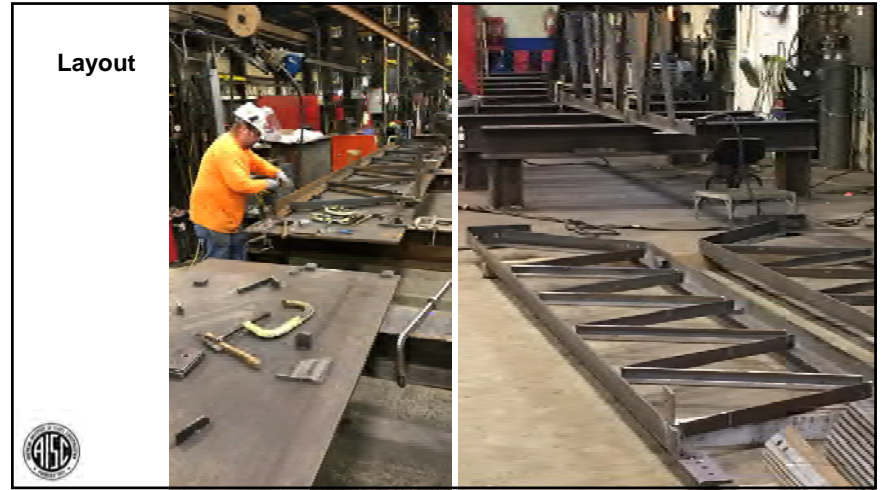
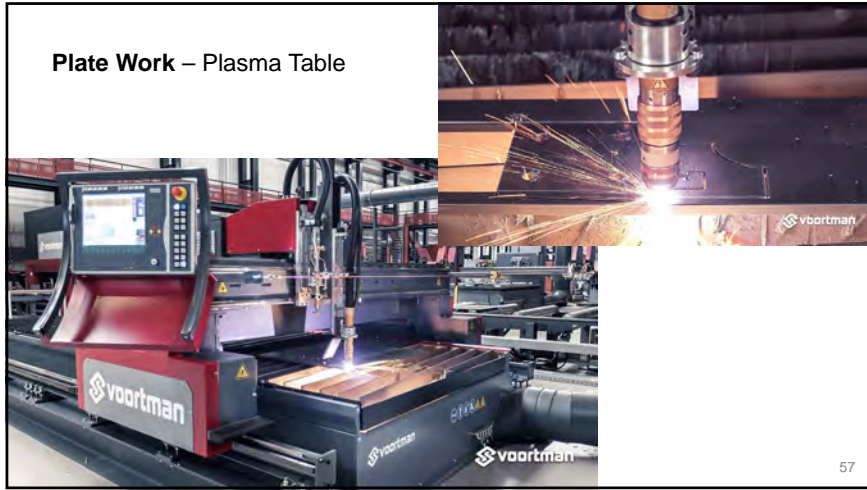

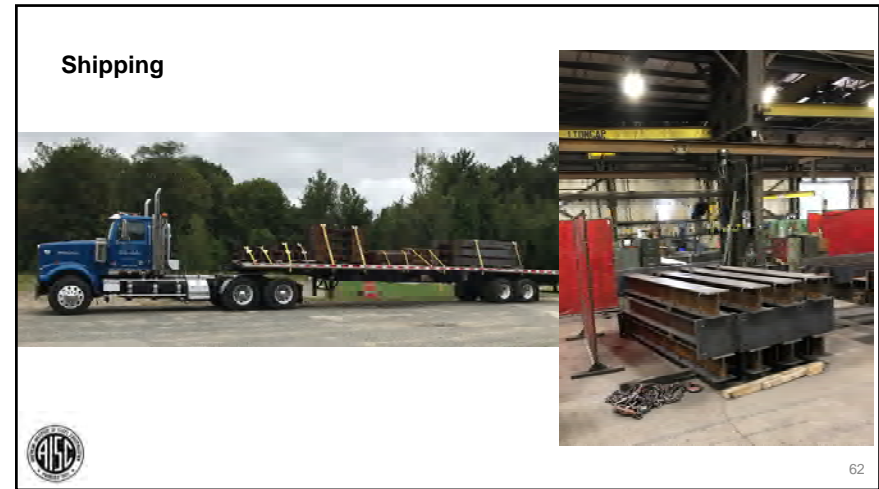
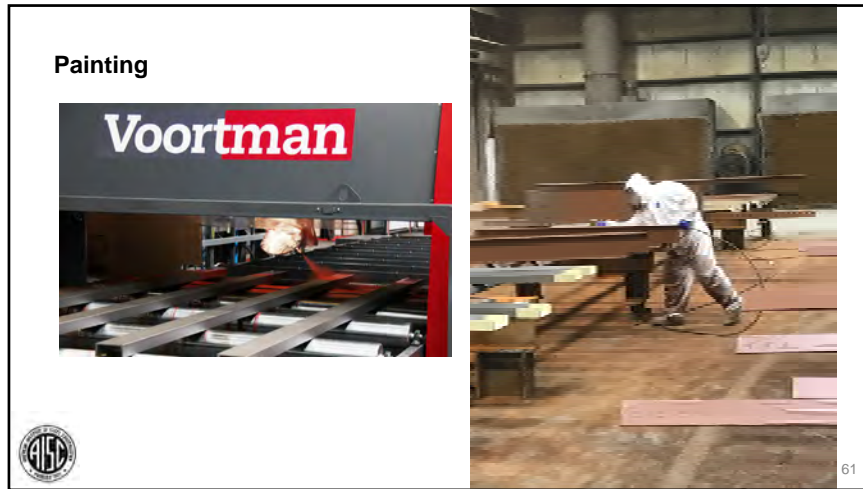

Outline

1. The Team	6. The Fabricator
2. The Owner/Architect	7. The Detailer
3. The ODRD (EOR)	8. The Connection Designer
4. The ODRD (Construction Manager)	9. The Erector
5. The Mill	10. The Erection Engineer
	11. Quality Control

63

7. The Detailer Section 4

- Produces *approval documents* for structural steel from ODRD design documents
- Structural steel shop drawings & erection drawings—and/or digital fabrication & erection models
- Often hired by fabricator – Can work to the strengths of the fabricator (shop welded vs. shop bolted, connection types, marking scheme, phasing/sequencing)
- Input from connection designer

64



Historic Detailing

- Hand drawn
- To scale
- Complex drawings
- Combined parts (Right/Left)

65

Historic Detailing

66

Modern Detailing

- BIM = Building Information Modeling
- Full steel structure modeled in 3D software (Tekla, SDS/2)
 - Sometimes using input from design model, but often built from scratch
- Phasing, scheduling can be built in via user-defined attributes
- Computer-generated drawings are a “snapshot” of the model
- Many thousands of drawings, transmitted and reviewed electronically
- Coordinate with other trades working in 3D

Rendering Courtesy of Ghafari

67

Part Drawings

- Show information required to fabricate a single piece of steel (gusset plate, connection angle, etc)
- Gather sheet – collection of part details
- Computer generated CNC files, DXF files

68



Assembly Drawings

MARK	QTY	DESCRIPTION	LENGTH	WEIGHT	REMARKS
B01	1	W8X15	10'-0"	450	
B02	2	W8X15	10'-0"	900	
B03	4	W8X15	10'-0"	1800	
B04	2	W8X15	10'-0"	900	
TOTAL WEIGHT THIS DRAWING					3050

- Show shop assembled fabrications (beam with end connections, gusset plates, etc.)

Notes:
 1. ALL DIMENSIONS SHOWN ARE FROM FACE UNLESS OTHERWISE NOTED.
 2. ALL DIMENSIONS SHALL BE TO CENTERLINE UNLESS OTHERWISE NOTED.
 3. ALL DIMENSIONS SHALL BE TO CENTERLINE UNLESS OTHERWISE NOTED.
 4. ALL DIMENSIONS SHALL BE TO CENTERLINE UNLESS OTHERWISE NOTED.
 5. ALL DIMENSIONS SHALL BE TO CENTERLINE UNLESS OTHERWISE NOTED.
 6. ALL DIMENSIONS SHALL BE TO CENTERLINE UNLESS OTHERWISE NOTED.
 7. ALL DIMENSIONS SHALL BE TO CENTERLINE UNLESS OTHERWISE NOTED.
 8. ALL DIMENSIONS SHALL BE TO CENTERLINE UNLESS OTHERWISE NOTED.
 9. ALL DIMENSIONS SHALL BE TO CENTERLINE UNLESS OTHERWISE NOTED.
 10. ALL DIMENSIONS SHALL BE TO CENTERLINE UNLESS OTHERWISE NOTED.

ruby • associates
 ENGINEERING ARCHITECTURE
 10000 W. 10th Ave., Suite 100
 Denver, CO 80202
 Phone: 303.755.1000
 Fax: 303.755.1001
 www.rubyassociates.com

Project: [REDACTED]
 Date: [REDACTED]
 Drawn: [REDACTED]
 Checked: [REDACTED]
 Title: [REDACTED]
 Scale: [REDACTED]
 Sheet: [REDACTED] of [REDACTED]
 Revision: [REDACTED]

Truss Drawing

Notes:
 1. ALL DIMENSIONS SHOWN ARE FROM FACE UNLESS OTHERWISE NOTED.
 2. ALL DIMENSIONS SHALL BE TO CENTERLINE UNLESS OTHERWISE NOTED.
 3. ALL DIMENSIONS SHALL BE TO CENTERLINE UNLESS OTHERWISE NOTED.
 4. ALL DIMENSIONS SHALL BE TO CENTERLINE UNLESS OTHERWISE NOTED.
 5. ALL DIMENSIONS SHALL BE TO CENTERLINE UNLESS OTHERWISE NOTED.
 6. ALL DIMENSIONS SHALL BE TO CENTERLINE UNLESS OTHERWISE NOTED.
 7. ALL DIMENSIONS SHALL BE TO CENTERLINE UNLESS OTHERWISE NOTED.
 8. ALL DIMENSIONS SHALL BE TO CENTERLINE UNLESS OTHERWISE NOTED.
 9. ALL DIMENSIONS SHALL BE TO CENTERLINE UNLESS OTHERWISE NOTED.
 10. ALL DIMENSIONS SHALL BE TO CENTERLINE UNLESS OTHERWISE NOTED.

ruby • associates
 ENGINEERING ARCHITECTURE
 10000 W. 10th Ave., Suite 100
 Denver, CO 80202
 Phone: 303.755.1000
 Fax: 303.755.1001
 www.rubyassociates.com

Project: [REDACTED]
 Date: [REDACTED]
 Drawn: [REDACTED]
 Checked: [REDACTED]
 Title: [REDACTED]
 Scale: [REDACTED]
 Sheet: [REDACTED] of [REDACTED]
 Revision: [REDACTED]

Erection Drawings

- Instructions for field installation
- Show enough detail that erector can put everything in place and connect it, but no "design" information

Notes:
 1. ALL DIMENSIONS SHOWN ARE FROM FACE UNLESS OTHERWISE NOTED.
 2. ALL DIMENSIONS SHALL BE TO CENTERLINE UNLESS OTHERWISE NOTED.
 3. ALL DIMENSIONS SHALL BE TO CENTERLINE UNLESS OTHERWISE NOTED.
 4. ALL DIMENSIONS SHALL BE TO CENTERLINE UNLESS OTHERWISE NOTED.
 5. ALL DIMENSIONS SHALL BE TO CENTERLINE UNLESS OTHERWISE NOTED.
 6. ALL DIMENSIONS SHALL BE TO CENTERLINE UNLESS OTHERWISE NOTED.
 7. ALL DIMENSIONS SHALL BE TO CENTERLINE UNLESS OTHERWISE NOTED.
 8. ALL DIMENSIONS SHALL BE TO CENTERLINE UNLESS OTHERWISE NOTED.
 9. ALL DIMENSIONS SHALL BE TO CENTERLINE UNLESS OTHERWISE NOTED.
 10. ALL DIMENSIONS SHALL BE TO CENTERLINE UNLESS OTHERWISE NOTED.

ruby • associates
 ENGINEERING ARCHITECTURE
 10000 W. 10th Ave., Suite 100
 Denver, CO 80202
 Phone: 303.755.1000
 Fax: 303.755.1001
 www.rubyassociates.com

Project: [REDACTED]
 Date: [REDACTED]
 Drawn: [REDACTED]
 Checked: [REDACTED]
 Title: [REDACTED]
 Scale: [REDACTED]
 Sheet: [REDACTED] of [REDACTED]
 Revision: [REDACTED]

Erection Drawings

Notes:
 1. ALL DIMENSIONS SHOWN ARE FROM FACE UNLESS OTHERWISE NOTED.
 2. ALL DIMENSIONS SHALL BE TO CENTERLINE UNLESS OTHERWISE NOTED.
 3. ALL DIMENSIONS SHALL BE TO CENTERLINE UNLESS OTHERWISE NOTED.
 4. ALL DIMENSIONS SHALL BE TO CENTERLINE UNLESS OTHERWISE NOTED.
 5. ALL DIMENSIONS SHALL BE TO CENTERLINE UNLESS OTHERWISE NOTED.
 6. ALL DIMENSIONS SHALL BE TO CENTERLINE UNLESS OTHERWISE NOTED.
 7. ALL DIMENSIONS SHALL BE TO CENTERLINE UNLESS OTHERWISE NOTED.
 8. ALL DIMENSIONS SHALL BE TO CENTERLINE UNLESS OTHERWISE NOTED.
 9. ALL DIMENSIONS SHALL BE TO CENTERLINE UNLESS OTHERWISE NOTED.
 10. ALL DIMENSIONS SHALL BE TO CENTERLINE UNLESS OTHERWISE NOTED.

ruby • associates
 ENGINEERING ARCHITECTURE
 10000 W. 10th Ave., Suite 100
 Denver, CO 80202
 Phone: 303.755.1000
 Fax: 303.755.1001
 www.rubyassociates.com

Project: [REDACTED]
 Date: [REDACTED]
 Drawn: [REDACTED]
 Checked: [REDACTED]
 Title: [REDACTED]
 Scale: [REDACTED]
 Sheet: [REDACTED] of [REDACTED]
 Revision: [REDACTED]



Approval Document Review

Section 4

- Owner required to deliver design documents
 - Expected to be “Frozen” or “Locked Layout” so detailing can proceed smoothly
- Fabricator required to produce approval documents
- Shop detail drawings and E-sheets – or model can be used as approval document and reviewed along with/instead of drawings
- Reviewed by ODRD & ODRC (Sec. 4.4)
 - Confirmation fabricator has correctly interpreted contract documents
 - Confirmation ODRD has reviewed & approved connection details
 - Release to begin fabrication
- Fabricator still responsible for accuracy of dimensions, general fitup



73

Outline

1. The Team
2. The Owner/Architect
3. The ODRD (EOR)
4. The ODRC (Construction Manager)
5. The Mill
6. The Fabricator
7. The Detailer
8. The Connection Designer
9. The Erector
10. The Erection Engineer
11. Quality Control



74

8. The Connection Designer

Night School 18.4!

- Designs connections...
- Can be provided in-house by EOR, or contracted by owner, fabricator, or detailer



AISC Steel Sculpture, Polytechnic University of Puerto Rico



75

Three Connection Design Options

Section 3.1.1

- Option 1: The complete connection design shall be shown on the structural design documents.
- Option 2: The connection shall be designated to be selected or completed by an experienced steel detailer.
- Option 3: The connection shall be designated to be designed by a licensed engineer.
 - Option 3A vs 3B



76



Option 1 – Shown on design documents

- Connection design performed as part of the EOR team
- Almost always used on west coast, especially in seismic design where EOR needs more control of connections



77

Option 2 – Selected/completed by detailer

- EOR to provide:
 - Loads that are to be resisted at each connection
 - “% of UDL” (% of maximum capacity per AISC load tables) is discouraged
 - Whether LRFD or ASD is to be used
 - Any restrictions on the types of connections permitted
 - What substantiating information must be provided with approval documents
- Loads can be provided on drawings, tables, or in design model.
- Intent is that detailer selects connection materials from tables (AISC Manual section 9, e.g.)
- Per commentary, not intended “...when the practice of engineering is required.”



78

Option 3 – Delegated Connection Design

- During the 1960s, fabricators were switching from rivets to bolts and welding, and offered to EORs that they could design their own connections
- Why delegate?
 - Connections can be hard! Connection design can be very specialized
 - Fabricators have different preferences
 - Take advantage to provide economy to project
- Finally added to COSP in 2010



Ruby+Associates

79



Option 3A/3B – Member Reinforcing

Section 3.1.2

- Member reinforcing ≠ connection design
- EOR **shall** provide design of web openings, bearing stiffeners, doublers, and other reinforcement **away** from connections
- **Option 3A** – EOR designs all member reinforcement at connections
- **Option 3B** – EOR provides project-specific conceptual details and estimated quantity for bidding purposes
- “Clean Columns” may save cost over reinforcing
 - AISC Spreadsheet at www.steeltools.org/column.php



80



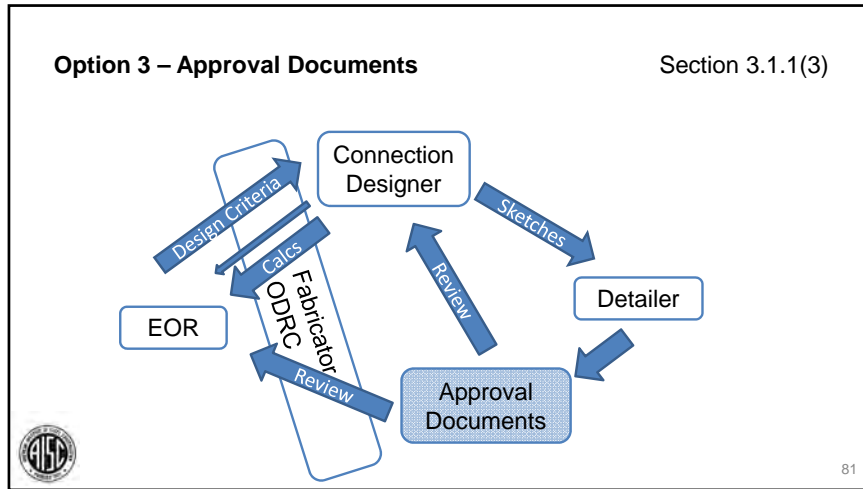

- Option 3 – Delegated Connection Design**
- May be used for only a portion of the design
 - Shear connections may be selected from tables or computer-designed (SDS/2, Qnect, Giza, etc.)
 - Bracing or truss connections are commonly delegated
 - Substantiating information may vary from a signed and sealed cover letter, to full calculation package
 - Representative samples reviewed before preparation of full set
 - Each sheet of shop and erection drawings should not be sealed by a PE (Commentary 3.1.1(3))
- 82

Types of Connections – Reference Information www.aisc.org/dg

- Bolts
- Welds
- Simple Shear
- Moment
- Bracing
- Column Base

83

- Coordination with Fabricator**
- Connection designer must work closely with fabricator, detailer, and erector (and EOR) to provide efficient designs
 - Bolt sizes & grades: Maintain few bolt types, preferably each type is a different size, preferably skip 1/8" increments
e.g. 3/4" dia. Group A and 1" dia. Group B
 - Hole types: Standard, short slot, or oversized for ease of erection
 - Welding preferences: Shop or field, preferred process and groove type
 - Shear connection preferences: single angle, shear tab, extended shear tab
 - Moment connection preferences: flange plate vs direct, welds vs bolts, etc.
- 84



Outline

1. The Team
2. The Owner/Architect
3. The ODRD (EOR)
4. The ODRC (Construction Manager)
5. The Mill
6. The Fabricator
7. The Detailer
8. The Connection Designer
9. The Erector
10. The Erection Engineer
11. Quality Control



85

9. The Erector

- “The erector shall be responsible for the means, methods, and safety of erection of the structural steel frame” (Section 1.9)
- Section 7, “Erection,” starts with a list of responsibilities of the ODRC before the erector can begin

Night School 18.5!



Ruby+Associates

86

Means, Methods, and Safety of Erection

- “‘Means and methods’ refers to the approach to or manner of construction, including amount of labor, material, and equipment necessary to implement the selected technique adopted by the contractor to perform work. In general, a contractor’s ‘means and methods’ refers to the course of construction undertaken by the contractor.” (American Bar Association, via AISC)
- Erection engineering – helps erector determine his/her ‘approach’ and ‘manner’ and provides stability of the structure during erection.



87

Tolerances

Section 7.13

- A major portion of the COSP defines erection tolerances
- These tolerances are coordinated with fabrication tolerances (Section 6.4), with other trades (concrete, façade, etc.) and with design practices
 - Direct analysis notional load 0.002Y comes directly from H/500 maximum out of plumbness of the constructed structure
- These tolerances haven’t changed significantly since 1959
 - The owner/EOR/ODRC shouldn’t try to change them arbitrarily
 - Architecturally Exposed Structural Steel (AESS) may be specified (in accordance with COSP Section 10), but this can add project cost



88



Tolerances

- Written tolerance descriptions summarized graphically in commentary
- Column location summary chart (Fig C-7.5)

Envelope within which all working points must fall.

Tolerance on location of $\pm 1/2$ at base.

89

Anchor Bolt Tolerances

Section 7.5.1

- As noted, ODRC responsible for setting anchor bolts
- Tolerances provided in 7.5.1
- Coordinated with recommended base plate hole sizes in AISC Steel Construction Manual

(b) The horizontal variation in location from the specified position of each anchor rod centerline at any location along its projection above the concrete shall be equal to or less than the dimensions given for the anchor rod diameters listed as follows:

Anchor Rod Diameter, in. (mm)	Horizontal Variation, in. (mm)
1/4 and 3/8 (19 and 25)	1/4 (6)
1/2 (25)	3/8 (10)
3/4, 1, 1 1/4 (40, 50, 63)	1/2 (13)

Anchor Rod Diameter	Hole Diameter	Washer Size	Min. Washer Thickness	Anchor Rod Diameter	Hole Diameter	Washer Size	Min. Washer Thickness
in.	in.	in.	in.	in.	in.	in.	in.
1/4	1 1/8	2	5/16	1/2	2 1/2	4	1/2
3/8	1 3/8	2 1/2	5/16	3/4	2 7/8	4 1/2	5/16
1	1 7/8	3	5/8	2	3 1/2	5	5/8
1 1/4	2 1/8	3 1/2	5/8	2 1/2	3 7/8	5 1/2	5/8

Notes:
1. These sizes provided are based on anchor rod size and diameter with AISC 17 (AISC 2010).
2. Diameter of rigid washers meeting the washer size are acceptable.
3. Clearance must be maintained when tolerances are exceeded unless rigid washers, using effects such as the position of the rod in the hole with respect to the column, web hole, and other considerations.
4. ASTM A307 washers are permitted instead of plate washers when their thicknesses are limited to 1/2 in. for rod diameters up to 1 in., 5/8 in. for rod diameters over 1 in. up to 2 in., and 3/4 in. for rod diameters over 2 in. The manufacturer should be called unless the general contractor has agreed to meet specific tolerances for anchor rod placement from those permitted in AISC 17.

90

Correction of Errors

Section 7.14 Night School 18.7!

- “Moderate amounts of reaming, grinding, welding, or cutting, and the drawing of elements into line with drift pins, shall be considered to be normal erection operations.”

DESIGN GUIDE 23 / CONSTRUCTIBILITY OF STRUCTURAL STEEL BUILDINGS / 43

91

“Why a Christmas Tree?”
Modern Steel Construction,
December 2000
www.modernsteel.org

Courtesy of Williams Enterprises

92

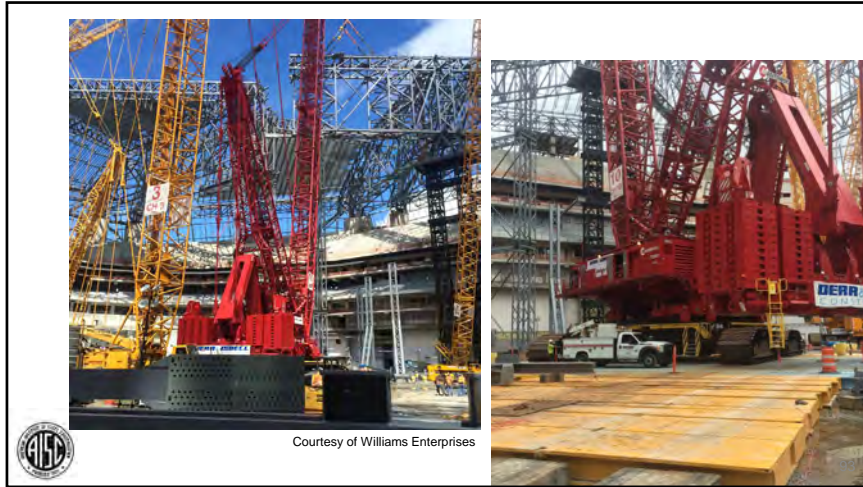

Outline

1. The Team
2. The Owner/Architect
3. The ODRD (EOR)
4. The ODRC (Construction Manager)
5. The Mill
6. The Fabricator
7. The Detailer
8. The Connection Designer
9. The Erector
10. The Erection Engineer
11. Quality Control



95

10. The Erection Engineer

Night School 18.6!

- EOR responsible for the structural adequacy and code compliance of the completed structure, but how does it get built?
- Erection Engineering provides an analysis of the structure at various stages of construction to ensure an adequate load path is provided at all times.
- Usually hired by erector, but may be retained by ODRC to prepare erection plan so all erectors have a consistent baseline for bidding.



96



Lateral Force Resisting System

Section 7.10

- EOR shall identify:
 - "The LFRS and connecting diaphragm elements that provide for lateral strength and stability in the completed structure"
 - "Any special erection conditions...such as the use of shores, jacks, or loads that must be adjusted...to set or maintain camber, position within specified tolerances, or prestress." (7.10.1)
- ODRC shall identify installation schedule for non-steel elements of the LFRS and connecting diaphragm – prior to bidding
 - E.g. erector may need to leave temporary bracing in place until concrete shear walls have reached sufficient strength.



97

Bracing Provided by Erector

Section 7.10.3

- "...the erector shall determine, furnish and install all temporary supports, such as temporary guys, beams, falsework, cribbing or other elements required for the erection operation. These temporary supports shall be sufficient to secure the bare structural steel framing or any portion thereof against loads that are likely to be encountered during erection, including those due to wind and those that result from erection operations.
"The erector need not consider loads during erection that result from the performance of work by, or the acts of, others, except as specifically identified by the owner's designated representatives for design and construction, nor those that are unpredictable, such as loads due to hurricane, tornado, earthquake, explosion or collision.
"Temporary supports that are required during or after the erection of the structural steel frame for the support of loads caused by non-structural steel elements, including cladding, interior partitions and other such elements that will induce or transmit loads to the structural steel frame during or after erection, shall be the responsibility of others."



98

Bracing Provided by Erector

Section 7.10.3

- "...the erector shall determine, furnish and install all temporary supports, such as temporary guys, beams, falsework, cribbing or other elements required for the erection operation. These temporary supports shall be sufficient to secure the bare structural steel framing or any portion thereof against loads that are likely to be encountered during erection, including those due to wind and those that result from erection operations.
"The erector need not consider loads during erection that result from the performance of work by, or the acts of, others, except as specifically identified by the owner's designated representatives for design and construction, nor those that are unpredictable, such as loads due to hurricane, tornado, earthquake, explosion or collision.
"Temporary supports that are required during or after the erection of the structural steel frame for the support of loads caused by non-structural steel elements, including cladding, interior partitions and other such elements that will induce or transmit loads to the structural steel frame during or after erection, shall be the responsibility of others."



99

Bracing Provided by Erector

Section 7.10.3

- "... the erector shall determine, furnish and install all temporary supports, such as temporary guys, beams, falsework, cribbing or other elements required for the erection operation. These temporary supports shall be sufficient to secure the bare structural steel framing or any portion thereof against loads that are likely to be encountered during erection, including those due to wind and those that result from erection operations.
"The erector need not consider loads during erection that result from the performance of work by, or the acts of, others, except as specifically identified by the owner's designated representatives for design and construction, nor those that are unpredictable, such as loads due to hurricane, tornado, earthquake, explosion or collision.
"Temporary supports that are required during or after the erection of the structural steel frame for the support of loads caused by non-structural steel elements, including cladding, interior partitions and other such elements that will induce or transmit loads to the structural steel frame during or after erection, shall be the responsibility of others."



100



Bracing Provided by Erector Section 7.10.3

- “... the erector shall determine, furnish and install all temporary supports, such as temporary guys, beams, falsework, cribbing or other elements required for the erection operation. These temporary supports shall be sufficient to secure the bare structural steel framing or any portion thereof against loads that are likely to be encountered during erection, including those due to wind and those that result from erection operations.
 “The erector need not consider loads during erection that result from the performance of work by, or the acts of, others, except as specifically identified by the owner’s designated representatives for design and construction, nor those that are unpredictable, such as loads due to hurricane, tornado, earthquake, explosion or collision.
 “Temporary supports that are required during or after the erection of the structural steel frame for the support of loads caused by non-structural steel elements, including cladding, interior partitions and other such elements that will induce or transmit loads to the structural steel frame during or after erection, shall be the responsibility of others.”



101

Bracing Provided by Erector Section 7.10.3

- “... the erector shall determine, furnish and install all temporary supports, such as temporary guys, beams, falsework, cribbing or other elements required for the erection operation. These temporary supports shall be sufficient to secure the bare structural steel framing or any portion thereof against loads that are likely to be encountered during erection, including those due to wind and those that result from erection operations.
 “The erector need not consider loads during erection that result from the performance of work by, or the acts of, others, except as specifically identified by the owner’s designated representatives for design and construction, nor those that are unpredictable, such as loads due to hurricane, tornado, earthquake, explosion or collision.
 “Temporary supports that are required during or after the erection of the structural steel frame for the support of loads caused by non-structural steel elements, including cladding, interior partitions and other such elements that will induce or transmit loads to the structural steel frame during or after erection, shall be the responsibility of others.”



102

Loads ASCE7, ASCE37

- Other than gravity load, mainly concerned about wind (ice?)
- Per ASCE37-14 (6.2.1), reduce design wind speed by a factor for project duration to adjust for risk
- 115mph * 0.8 → 64% of EOR’s design wind pressure
- However! Wind load collected by the open structure can be much higher than wind on the final enclosed building
 - Shape Factor, Cf
 - Shielding

6.2.1 Design Wind Speed The design wind speed shall be taken as the following factor times the basic wind speed in ASCE/SEI 7-10, except as required in Section 6.2.1.1.1.

Construction Period	Factor
Less than six weeks	0.75
From six weeks to one year	0.8
From one to two years	0.85
From two to five years	0.9

Other Structures	Force Coefficients, G	All Heights
Figure 26.2-2		Open Signs & Lattice Frameworks



103

Hurricane Loads ASCE37-14 6.2.1.1.1

- Per COSP, hurricane loads not required to be considered
- ASCE37 provides wind reduction outside hurricane season, but July through October allows a 115 mph wind speed even near the coast “provided additional bracing is prepared in advance and applied in time before the onset of an announced hurricane.”
- Hurricane contingency plan can be very costly. Communications with erector, ODRC, and owner are crucial at the beginning of the project (not when the wind picks up!)

Erection Engineering

- Structure stability – analysis of partially completed structure at each stage of the procedure
- Element stability – analysis of installation of a major element of the structure (truss, subassembled module, cantilever)
- Staged construction – accumulation of dead load stresses that are “locked in” as portions of structure are added



105

Structure Stability (“Erection Staging”)

- Each stage of erection is a separate analysis
- Load path may be much different than final design
- Temporary bracing provided (usually wire rope) until enough structure is complete to handle the load
- Erector usually wants to know how far ahead of steel deck erection can proceed

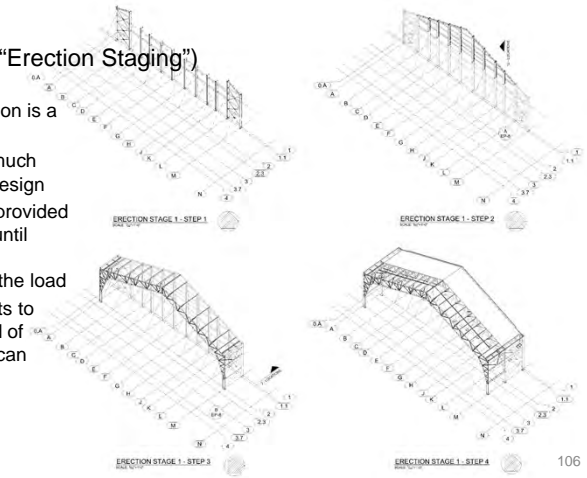

106

Structure Stability (“Erection Staging”)

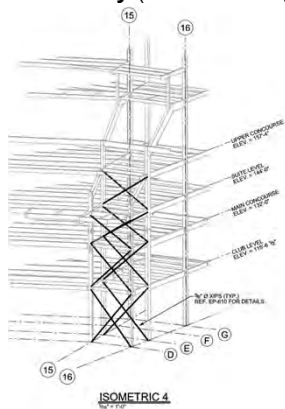

ISOMETRIC 4

Ruby+Associates

107

Element stability

- Analysis of truss or girder under the hook, review of stability before releasing crane

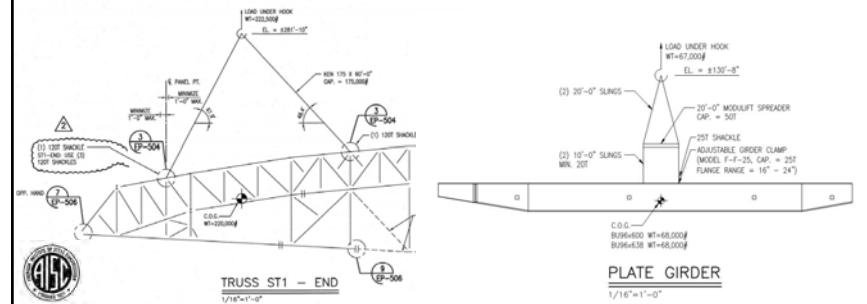

Staged Construction Analysis

- Highly indeterminate buildings, multiple load paths
- Especially on cable supported structures
- Construction or cable tensioning sequence can greatly affect stresses within the structure



Outline

1. The Team
2. The Owner/Architect
3. The ODRD (EOR)
4. The ODRC (Construction Manager)
5. The Mill
6. The Fabricator
7. The Detailer
8. The Connection Designer
9. The Erector
10. The Erection Engineer
11. Quality Control



110

11. Quality Control

Section 8.1
Night School 18.8!

- Fabricator (8.1.1) and Erector (8.1.2) shall maintain a quality control program to ensure work is in conformance with COSP, AISC360 "Specification," and contract documents.
- AISC Specification Chapter N "...addresses the minimum requirements for quality control, quality assurance and nondestructive testing..." (Chapter N Scope)



111

Specification Chapter N

- Provides guidance for steel inspection, quality program for *all* fabricators & erectors
- New chapter in 2010, but not necessarily new requirements—pulls together all of the quality requirements necessary for steel construction in one place.
- Best part: EOR just has to specify AISC360 and COSP to ensure consistent quality program is required.



Courtesy of Williams Enterprises

112



QC vs. QA?

- Per ISO9000 (Section 3.2.10 and 11)
 - QC: "A part of quality management focused on fulfilling quality requirements"
 - QA: "part of quality management focused on providing confidence that quality requirements will be fulfilled"



113

QC vs. QA

- Per ISO9000 (Section 3.2.10 and 11)
 - QC: "A part of quality management focused on fulfilling quality requirements"
 - QA: "part of quality management focused on providing confidence that quality requirements will be fulfilled"
- Per Chapter N1:
 - "Quality Control...shall be provided by **fabricator and erector.**"
 - "Quality Assurance...shall be provided by **others** when required by the authority having jurisdiction (AHJ), applicable building code, purchaser, owner, or engineer of record (EOR)."
- Coordinated QC & QA is permitted
 - If approved by EOR or AHJ, QA inspector can rely on QC inspector for overlapping tasks



114

Observe vs. Perform

- Observe (O): Inspector shall observe these items on a random basis
- Perform (P): Tasks shall be performed for each welded joint/bolted connection
- Similar to IBC "Continuous vs. Periodic" for special inspections
 - IBC only provides tables for joists, concrete, soils, and foundations

TYPE	CONTINUOUS SPECIAL INSPECTION	PERIODIC SPECIAL INSPECTION	REFERENCE STANDARD ¹	IBC REFERENCE
1. Inspect reinforcement, including prestressing tendons, and verify placement	—	X	ACI 308.3R, 308.3, 308.3.1, 308.3.2	1703.4
2. Inspecting for welding <ul style="list-style-type: none"> a. Verify weldability of reinforcing bars when using ASTM A615 b. Inspect single pass fillet welds, minimum 7/16" c. Inspect all other welds 	—	X	ANSI D4.4 ACI 308.20.4-4	—
3. Inspect anchors cast in concrete	—	X	ACI 308.17.8.2	—
4. Inspect anchors pre-installed in hardened concrete members <ul style="list-style-type: none"> a. Adhesive anchors installed in accordance with approved technical instructions as noted b. Mechanical anchors and adhesive anchors per defined as a. 	X	X	ACI 308.17.8.2.4 ACI 308.17.8.2	—
5. Verify use of rebar design max.	—	X	ACI 308.15.1F, 304.2, 304.4	1903.1, 1903.2, 1903.3, 1903.4
6. Prior to concrete placement, fabricate spec.	—	X	ACI 308.17.1.1	—



115

Inspection requirements

- N5.4 – Welding
- N5.5 – NDT
- N5.6 - Bolting

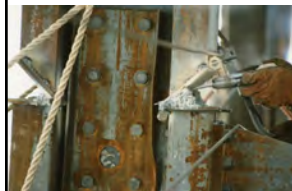

Courtesy of Williams Enterprises

TABLE N5.6-1
Inspection Tasks Prior to Bolting

Inspection Tasks Prior to Bolting	QC	QA
Manufacturer's certifications available for fastener materials	O	P
	O	O
	O	O
	O	O

TABLE N5.4-1
Inspection Tasks Prior to Welding

Inspection Tasks Prior to Welding	QC	QA
Welding procedure specifications (WPSs) available	P	P
Manufacturer certifications for welding consumables available	P	P
Material identification (type/grade)	O	O
Welder identification system ¹	O	O
Fit-up of groove welds (including joint geometry) <ul style="list-style-type: none"> • Joint preparation • Dimensions (alignment, root opening, root face, bevel) • Cleanliness (condition of steel surfaces) • Tackling (lack weld quality and location) 	O	O

116



Conclusion

Night School 18

- 18.1 Introduction to the Steel Construction Process Oct. 15
- 18.2 The Manufacturing of Structural Steel Shapes Oct. 22
- 18.3 A Virtual, Detailed Tour of the Steel Fabrication Process Oct. 29
- 18.4 Connection Design as the Fabricator's Representative Nov. 5
- 18.5 It Doesn't Get Built Without the Erector Nov. 19
- 18.6 Erection Engineering – Stability During Construction Nov. 26
- 18.7 Field Fixes and Solutions Dec. 3
- 18.8 Quality Control and Quality Assurance Dec. 10

ANSI/AISC 358.16
 All American National Standard

**Code of Standard Practice
 for Steel Buildings
 and Bridges**

June 15, 2016

Supersedes the Code of Standard Practice for Steel Buildings and Bridges
 issued April 16, 2010 and all previous versions.

approved by the Committee on the Code of Standard Practice 117

Night School 18: Steel Construction

From the Mill to Topping Out

Session 1: Introduction to the Steel Construction Process

October 15, 2018 (The Team Behind the Building)

AISC | Questions?

Individual Webinar Registrants

CEU/PDH Certificates

Within 2 business days...

- You will receive an email on how to report attendance from: registration@aisc.org.
- Be on the lookout: Check your spam filter! Check your junk folder!
- Completely fill out online form. Don't forget to check the boxes next to each attendee's name!

Individual Webinar Registrants

CEU/PDH Certificates

Within 2 business days...

- New reporting site (URL will be provided in the forthcoming email).
- Username: Same as AISC website username.
- Password: Same as AISC website password.



8-Session Registrants

CEU/PDH Certificates

One certificate will be issued at the conclusion of all 8 sessions.



8-Session Registrants

Access to the quiz: Information for accessing the quiz will be emailed to you by Wednesday. It will contain a link to access the quiz. EMAIL COMES FROM NIGHTSCHOOL@AISC.ORG

Quiz and Attendance records: Posted Tuesday mornings.
www.aisc.org/nightschool - click on Current Course Details.

Reasons for quiz:

- EEU – must take all quizzes and final to receive EEU
- CEUs/PDHS – If you watch a recorded session you must take quiz for CEUs/PDHS.
- REINFORCEMENT – Reinforce what you learned tonight. Get more out of the course.

NOTE: If you attend the live presentation, you do not have to take the quizzes to receive CEUs/PDHS.



8-Session Registrants

Access to the recording: Information for accessing the recording will be emailed to you by this Wednesday. The recording will be available for three weeks. For 8-session registrants only. EMAIL COMES FROM NIGHTSCHOOL@AISC.ORG.

CEUs/PDHS – If you watch a recorded session you must take AND PASS the quiz for CEUs/PDHS.



Night School Resources for 8-session package Registrants

Find all your handouts, quizzes and quiz scores, recording access, and attendance information all in one place!



Night School Resources for 8-session package Registrants

Go to www.aisc.org and sign in.

The screenshot shows the AISC website homepage. At the top, there are navigation tabs for EDUCATION, PUBLICATIONS, NASCC: THE STEEL CONFERENCE, SAFETY, STEEL SOLUTIONS CENTER, AWARDS AND COMPETITIONS, and RESEARCH LIBRARY. Below the navigation is a large banner with the AISC logo and the text "AISC". Underneath the banner is a "Login" section with the text "If you're an existing customer, please enter your username and password." There are two input fields: "USERNAME" and "PASSWORD". To the right of the login form is a "DON'T HAVE AN ACCOUNT?" section with the text "My AISC allows you to access Engineering Journal articles and Design Guides you have downloaded from the bookstore." and a "REGISTER NOW" button.

Night School Resources for 8-session package Registrants

Go to www.aisc.org and sign in.

The screenshot shows the MyAISC user profile page. On the left side, there is a sidebar menu with items: "IN THIS SECTION", "Edit Profile", "My Downloads", "My Pending Quizzes", "My Events", "Order History", "Course History", and "Course Resources" (circled in red). The main content area has a "MyAISC" header and several sections: "MY PROFILE" with an "EDIT PROFILE" button, "MY PURCHASED DOWNLOADS" with a "VIEW DOWNLOADS" button, and "MY COURSE RESOURCES" (circled in red) with a "VIEW RESOURCES" button. The "MY COURSE RESOURCES" section includes the text "View online resources for Night School and Live Webinar package registrations."

Night School Resources for 8-session package Registrants

The screenshot shows the AISC website page for "Night School 13: Design of Industrial Buildings". The page title is "Night School 13: Design of Industrial Buildings" and the subtitle is "8-SESSION PACKAGE RESOURCES". Below the title is a table with columns: "Event", "Date", "Handouts", "Video", "Quiz", and "Attendance".

Event	Date	Handouts	Video	Quiz	Attendance
NS13 - Design Criteria	1/30/2017 7:00:00 PM	Handouts	Video	Pass Score 80	Pending
NS13 - Economic Considerations	2/6/2017 7:00:00 PM	Handouts	Available 02/08/2017 5pm EST	Available 03/08/2017 5pm EST	Pending
NS13 - Lateral Load Systems and Details	2/13/2017 7:00:00 PM	Handouts	Available 02/15/2017 5pm EST	Available 03/15/2017 5pm EST	Pending
NS13 - Preliminary Design Procedures	2/27/2017 7:00:00 PM	Handouts	Available 03/01/2017 5pm EST	Available 03/01/2017 5pm EST	Pending
NS13 - Crane Girder Design and Frame Analysis	3/6/2017 7:00:00 PM	Handouts	Available 03/08/2017 5pm EST	Available 03/08/2017 5pm EST	Pending
NS13 - Frame Member and Connection Design	3/13/2017 7:00:00 PM	Handouts	Available 03/15/2017 5pm EST	Available 03/15/2017 5pm EST	Pending
NS13 - Transfer Crane Girder & Longitudinal Bracing Design	3/27/2017 7:00:00 PM	Handouts	Available 03/29/2017 5pm EST	Available 03/29/2017 5pm EST	Pending
NS13 - Building Envelope and Bracing Design	4/3/2017 7:00:00 PM	Handouts	Available 04/05/2017 5pm EST	Available 04/05/2017 5pm EST	Pending
NS13 - Final Exam	4/10/2017 7:00:00 PM			Available 04/12/2017 5pm EST	

Night School Resources for 8-session package Registrants

- Weekly "quiz and recording" email.
- Weekly updates of the master Quiz and Attendance record found at www.aisc.org/nightschool. Scroll down to Quiz and Attendance records.
 - Updated on Tuesday mornings.



Night School Resources for 8-session package Registrants

- Webinar connection information:
 - Found in your registration confirmation/receipt.
 - Reminder email sent out Monday mornings.
- Link to handouts also found here.

