

Thank you for joining our live webinar today.

We will begin shortly.  
Please standby. Thank you.

Need Help?  
Call ReadyTalk Support:  
800.843.9166



**Connection Design**  
Tips, Tricks, and Lessons Learned



**Smarter.  
Stronger.  
Steel.**



**Audio Options**

Today's audio will be broadcast through the internet.

Alternatively, to hear the audio through the phone, dial:

(866)-519-2796  
Passcode: 324420



**Smarter.  
Stronger.  
Steel.**



**Today's live webinar will begin shortly. Please stand by.**

As a reminder, all lines have been muted. Please type any questions or comments through the chat feature on the left portion of your screen.

Today's audio will be broadcast through the internet.  
Alternatively, to hear the audio through the phone, dial:

(866)-519-2796  
Passcode: 324420



**Smarter.  
Stronger.  
Steel.**



**AIA Credit**

AISC is a Registered Provider with The American Institute of Architects Continuing Education Systems (AIA/CES). Credit(s) earned on completion of this program will be reported to AIA/CES for AIA members. Certificates of Completion for both AIA members and non-AIA members are available upon request.

This program is registered with AIA/CES for continuing professional education. As such, it does not include content that may be deemed or construed to be an approval or endorsement by the AIA of any material of construction or any method or manner of handling, using, distributing, or dealing in any material or product.

Questions related to specific materials, methods, and services will be addressed at the conclusion of this presentation.



**Smarter.  
Stronger.  
Steel.**



### Copyright Materials

This presentation is protected by US and International Copyright laws. Reproduction, distribution, display and use of the presentation without written permission of AISC is prohibited.

© The American Institute of Steel Construction 2019

The information presented herein is based on recognized engineering principles and is for general information only. While it is believed to be accurate, this information should not be applied to any specific application without competent professional examination and verification by a licensed professional engineer. Anyone making use of this information assumes all liability arising from such use.



### Course Description

#### 19.2 Delegating Connection Design February 11, 2019

The cost of connections is a significant percentage of the total cost of steel-framed structures. This webinar reviews how designers can efficiently delegate connection design in a manner that saves time, reduces RFI's, reduces cost, and conforms with the requirements of the Code of Standard Practice. This session discusses the EOR's responsibility regarding delegation of connection design as stipulated by the COSP and reviews how decisions made relative to framing configuration during design can substantially affect connection cost. Tips, guidelines, suggestions, and examples will be presented to provide designers of all levels of experience a better understanding on how to properly delegate connection design in a manner that will result in safer, more constructable, and more economical steel-framed building structures.



### Learning Objectives

- Identify examples of improper general notes when delegating connection design.
- List the two options for how to treat member reinforcing at connections, according to the AISC *Code of Standard Practice*.
- Describe the benefits of creating thoughtful conceptual details during the design phase of a project.
- Explain why engineers should be aware of the potential negative effects of eccentric structural load paths.



## Night School 19 Connection Design: Tips, Tricks, and Lessons Learned

Session 2: Delegating Connection Design  
February 11, 2019



Cliff Schwinger, PE

THE  
**HARMAN GROUP**  
structural engineering  
parking planning and design



PHILADELPHIA | NEW YORK



## Seminar Objectives

### Review / Discuss

- Connection design responsibilities per AISC 303-16
- AISC 303-16 Options “3A” and “3B”
- “Member reinforcing” at connections
- “Concept connection details”
- “Connection constructability” and “connection designability”
- Unusual connections (including “kinked connections”) and things to consider when delegating connection design



9

### Recommended reading

Delegation of connection design was discussed 124 years ago.

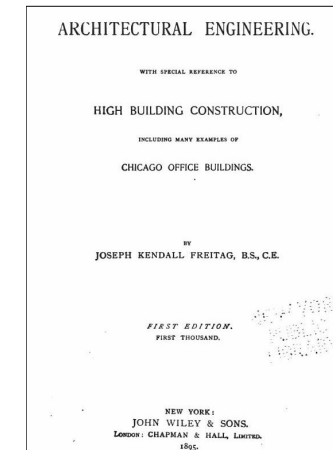

10

### Why delegate connection design?

- Delegating connection design is standard practice in some areas of the U.S.
- Schedules
- Connection design is a specialty
- Fabricator connection preferences



11

**There's a right way and a wrong way to delegate connection design**



12

### The wrong way

“Shear connections shall be designed to develop full shear strength of member.”

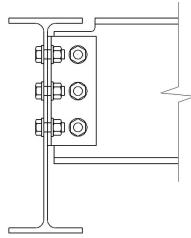

13

### The right way



14

### Follow AISC 303-16

The roadmap to navigating the proper way of delegating connection design

#### Code of Standard Practice for Steel Buildings and Bridges

ANSI/AISC 303-16  
An American National Standard

June 15, 2016

Supersedes the Code of Standard Practice for Steel Buildings and Bridges dated March 14, 2010 and all previous versions

Approved by the Committee on the Code of Standard Practice



AMERICAN INSTITUTE OF STEEL CONSTRUCTION  
130 East Randolph Street, Suite 2000, Chicago, Illinois 60601  
www.aisc.org



15

### Who is ultimately responsible for the safe design of all connections?

*The “...owner’s designated representative for design...”  
(the Engineer of Record)*



16

## Connection Design Responsibility

### From Section 1.9:

- 1.9.2. The structural engineer of record shall be responsible for the structural adequacy of the design of the structure in the completed project. The structural engineer of record shall not be responsible for the means, methods and safety of erection of the structural steel frame. See also Sections 3.1.4 and 7.10.



17

## Connection Design Responsibility

### From 4.4.1 Commentary:

... From the inception of this Code, AISC and the industry in general have recognized that only the *owner's designated representative for design* has all the information necessary to evaluate the total impact of connection details on the overall structural design of the project. This authority traditionally has been exercised during the approval process for the *approval documents*. The owner's designated representative for design has thus retained responsibility for the adequacy and safety of the entire structure since at least the 1927 edition of this Code.



18

## Connection Design Responsibility

### 4.4. Approval

Except as provided in Section 4.5, the *approval documents* shall be submitted to the *owner's designated representatives for design* and construction for review and approval. The *approval documents* shall be returned to the *fabricator* within 14 calendar days.

Final *substantiating connection information*, if any, shall also be submitted with the *approval documents*. The owner's designated representative for design is the final authority in the event of a disagreement between parties regarding the design of connections to be incorporated into the overall structural steel frame. The *fabricator* and licensed engineer in responsible charge of *connection* design are entitled to rely upon the *connection* design criteria provided in accordance with Section 3.1.1. *Revisions* to these criteria shall be addressed in accordance with Sections 9.3 and 9.4.

...



19

## SECTION 3. DESIGN DOCUMENTS AND SPECIFICATIONS

### 3.1. Structural Design Documents and Specifications

Unless otherwise indicated in the *contract documents*, the structural *design documents* shall be based upon consideration of the design loads and forces to be resisted by the *structural steel* frame in the completed project.

The structural design documents shall clearly show or note the work that is to be performed and shall give the following information with sufficient dimensions to accurately convey the quantity and complexity of the structural steel to be fabricated:

- (a) The size, section, material grade and location of all members.
- (b) All geometry and working points necessary for layout.
- (c) Floor elevations.
- (d) Column centers and offsets.
- (e) The camber requirements for members.
- (f) Preset elevation requirements, if any, at free ends of cantilevered members relative to their fixed-end elevations.
- (g) Joining requirements between elements of built-up members.
- (h) When the requirements of ANSI/AISC 341 are applicable, the information required in ANSI/AISC 341 Section A4.
- (i) The information required in Sections 3.1.1 through 3.1.6.

...



20

### Three options for connection design

3.1.1. The owner's designated representative for design shall indicate one of the following options for each connection:

- (1) Option 1: the complete connection design shall be shown in the structural design documents.
- (2) Option 2: in the structural design documents or specifications, the connection shall be designated to be selected or completed by an experienced steel detailer.
- (3) Option 3: in the structural design documents or specifications, the connection shall be designated to be designed by a licensed engineer working for the fabricator.

In all of the above options,

- (a) The requirements of Section 3.1.2 shall apply.
- (b) The approvals process in Section 4.4 shall be followed.

...

Code of Standard Practice for Steel Buildings and Bridges, June 15, 2016  
AMERICAN INSTITUTE OF STEEL CONSTRUCTION



21

### (3.1.1 continued)

... When Option 2 is specified, the experienced steel detailer shall utilize information provided in the structural design documents in the selection or completion of the connections. When such information is not provided, tables in the AISC Steel Construction Manual, or other reference information as approved by the owner's designated representative for design, shall be used.

When Option 2 or 3 is specified, the owner's designated representative for design shall provide the following connection design criteria in the structural design documents and specifications:

- ➔ (a) Any restrictions on the types of connections that are permitted.
- ➔ (b) Data concerning the loads, including shears, moments, axial forces and transfer forces, that are to be resisted by the individual members and their connections, sufficient to allow the selection, completion, or design of the connection details while preparing the approval documents.
- ➔ (c) Whether the data required in (b) is given at the service-load level or the factored-load level.
- ➔ (d) Whether LRFD or ASD is to be used in the selection, completion, or design of connection details.
- ➔ (e) What substantiating connection information, if any, is to be provided with the approval documents to the owner's designated representative for design.

...



22

### (3.1.1. continued)

... When Option 3 is specified:

- (a) The fabricator shall submit in a timely manner representative samples of the required substantiating connection information to the owner's designated representatives for design and construction. The owner's designated representative for design shall confirm in writing in a timely manner that these representative samples are consistent with the requirements in the contract documents, or shall advise what modifications are required to bring the representative samples into compliance with the requirements in the contract documents. This initial submittal and review is in addition to the requirements in Section 4.4.
- (b) The licensed engineer in responsible charge of the connection design shall review and confirm in writing as part of the substantiating connection information, that the approval documents properly incorporate the connection designs. However, this review by the licensed engineer in responsible charge of the connection design does not replace the approval process of the approval documents by the owner's designated representative for design in Section 4.4.
- (c) The fabricator shall provide a means by which the substantiating connection information is referenced to the related connections on the approval documents for the purpose of review.



23

### (3.1.2 continued)

... (2) When Option 3 in Section 3.1.1 is specified for a connection, two subsidiary options are available to the owner's designated representative for design; either:

- (a) Option 3A: member reinforcement at connections shall be designed by the owner's designated representative for design and shown in the structural design documents issued for bidding so that the quantity, detailing and fabrication requirements for member reinforcement at connections can be readily understood, or;
- (b) Option 3B: the owner's designated representative for design shall provide a bidding quantity of items required for member reinforcement at connections with corresponding project-specific details that show the conceptual configuration of reinforcement appropriate for the order of magnitude of forces to be transferred. These quantities and project-specific conceptual configurations will be relied upon for bidding purposes. If no quantities or conceptual configurations are shown, member reinforcement at connections will not be included in the bid.

Subsequently, member reinforcement at connections, where required, shall be designed in its final configuration by the licensed engineer in responsible charge of the connection design.

...



24

New term,

**“...member reinforcement at connections...”**

“Member reinforcement at connections” refers to stiffener plates, web doubler plates, and other elements required to deal with secondary stresses in members at connections.



25

**“...member reinforcement at connections...”**

**Option 3A**

Per Section 3.1.2, the EOR is responsible for,

- Determining where member reinforcement is required at connections
- Designing and detailing all member reinforcing at connections
- Documenting all locations where member reinforcing is required on the contract documents



26

**“...member reinforcement at connections...”**

**Option 3B**

Per Section 3.1.2, the EOR is responsible for,

- Providing concept connection details showing the configuration and details of the member reinforcement at connections
- Providing a bidding quantity of items required for member reinforcement at connections referencing “...corresponding project-specific details that show the conceptual configuration of reinforcement appropriate for the order of magnitude of forces to be transferred...”
- Delegating design of the connection and member reinforcing at connections to the fabricator’s connection design engineer



27

**“...member reinforcement at connections...”**

**Option 3B**

From Section 3.1.2,

“...If no quantities or conceptual configurations are shown, member reinforcement at *connections* will not be included in the bid...”.



28

Another new term,

“Conceptual configuration of reinforcement”

or

“Concept connection details”



29

“Concept connection details”

Two purposes,

- They show connection design engineers how connections are to be configured
- They provide connection details to fabricators bidding the project so that everyone is accounting for the same things when estimating cost.



30



Fig. 19.—Typical Framing Plan of the Reliance Building.

with such license on the part of the contractor, and the best classes of work are made in accordance with definite details furnished by the engineer, after a careful considera-

SKELETON CONSTRUCTION.

45

tion of the conditions to be fulfilled. This does not mean that complete shop drawings are made, but rather such connections and special points in the design as need particular attention. The balance of the detailing may be made to suit the contractor, with the approval of the engineer, in conformity with the sizes of material marked on the plan, and the carefully drawn specifications.

The idea of allowing the manufacturer to prepare complete details after his own general scheme, and following specifications only, is not consistent with best results, in the judgment of the writer, though such an arrangement has often been advocated. It is true that it has been a

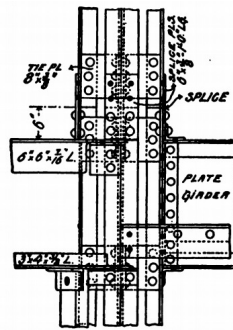

Fig. 104.



31

Concept connection detail

Note: The COSP does not specifically require that bolt sizes, weld sizes and plate sizes be shown in the “conceptual configuration of reinforcement” details

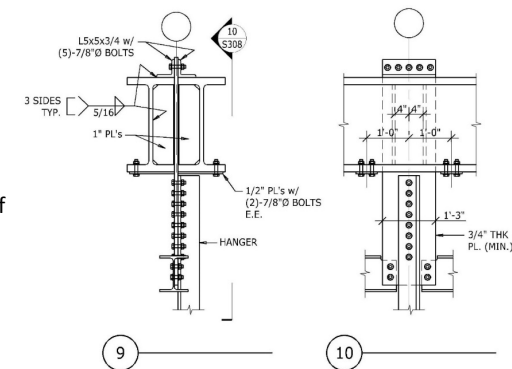

32

**In the absence of a concept connection detail....**

Concept connection details communicate the EOR's design intent, thereby avoiding time-consuming rejection of shop drawings, RFI's, arguments, misunderstandings between the EOR and the connection design engineer, and change orders.

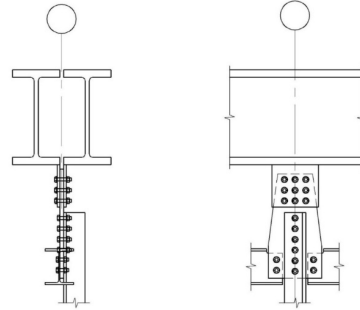

33

**Not an acceptable concept connection detail**

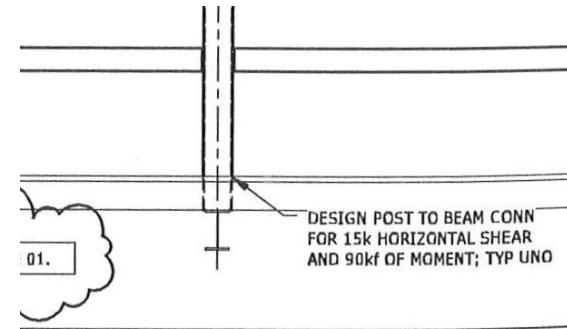

34

**Not an acceptable concept connection detail**

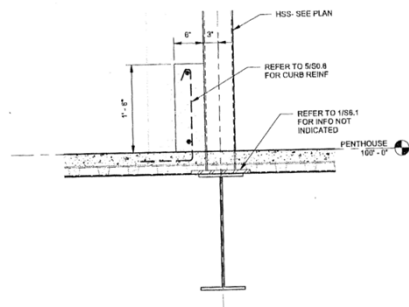

6 SECTION  
1" = 1'-0"

35

**Things to consider**

- Can the connections be built? (**Constructability**)
- Can the connections be designed? (**Connection designability**)
- Is there anything unusual about how loads travel through the connections? Are there any transfer forces with **eccentric** load paths through any of the connections that will require member reinforcement? (**Kinked connections**)



36

### What's a "kinked connection"?

Connections where the transfer forces follow an **eccentric** load path through the connection inducing secondary stresses

One kink in original connection;  
three kinks in final connection

1.6 strength ratio in original detail;  
3.2 strength ratio in final (revised) detail

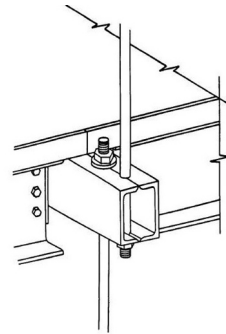

As Built



37

### Always be on the lookout for kinked connections

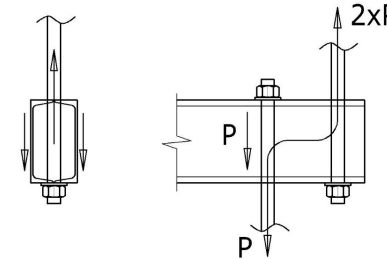

Eccentric load paths through connections induce secondary stresses in the member(s)



38



### Dealing with kinked connections

- Find the kinked connections **during design**
- Eliminate kinks if possible – or deal with them
- Provide “concept connection details” on structural drawings

Kinked connections are *everywhere!*



40

Kink in load path inducing secondary stresses in members

Concept connection detail addressing secondary stresses

41

### Kinked connections

42

### kinked connections

Who is responsible for checking the secondary stresses in the HSS?  
*(Both the EOR and connection design engineer)*

Who is ultimately responsible for the structural adequacy of the design of the completed project? (Section 1.9.2) *(The EOR)*

Who is responsible for providing project specific details showing conceptual configuration of reinforcement at the connections? (Section 3.1.2) *(The EOR)*

43

### kinked connections

(DESIGN HSS FOR TORSION)

Two possible concept connection details to eliminate secondary stresses in HSS

44

### Why provide “concept connection details”?

- Required by the AISC Code of Standard Practice (“...conceptual configuration of reinforcement...”)
- Allows fabricators to better estimate cost, reducing the number of assumptions made by estimators and leveling the playing field among bidders
- Gives guidance and direction to connection designers
- Gives EOR opportunity to find and resolve constructability issues, connection designability issues, and kinked connection issues during design



45

### Why provide “concept connection details”?

- The time to find and resolve connection issues is during design
- EOR has options during design (revise framing)
- The number of economical options for solving connection design problems is reduced if problems are not discovered until shop drawing review
- Concept connection details reduce RFI’s, change orders, and disputes, *and* reduce the likelihood of mistakes slipping through
- Concept connection details make buildings safer!



46

### Perform quick and basic calculations to develop realistic concept connection details

- Be sure the detail works!
- Be sure the detail is “within the ballpark”
- Be sure connection is designable!

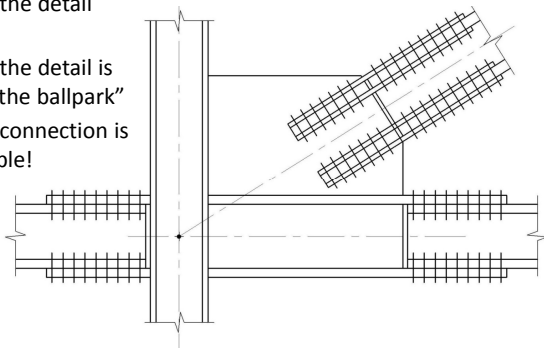

47

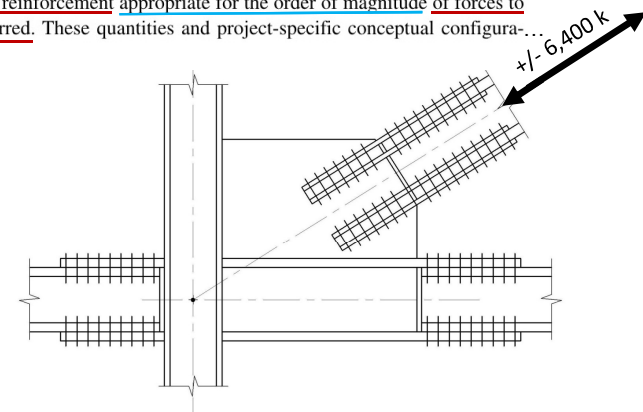

### From 3.1.2 (2)

...with corresponding project-specific details that show the conceptual configuration of reinforcement appropriate for the order of magnitude of forces to be transferred. These quantities and project-specific conceptual configura...

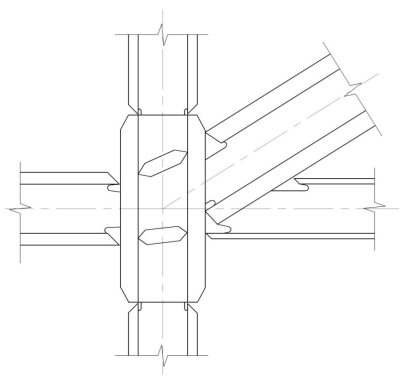

48

**Provide realistic concept connection details**

49

**Provide information on Transfer Forces**

*(What's a transfer force?)*





50

**Transfer Forces**



**29**  
Steel Design Guide



*Vertical Bracing Connections—  
Analysis and Design*

**APPENDIX D  
Transfer Forces**

The AISC *Code of Standard Practice for Steel Buildings and Bridges* (AISC, 2010a), hereafter referred to as the AISC *Code of Standard Practice*, states that, when the fabricator is required to design connection details, the structural design drawings shall provide, among other things, "data concerning the loads, including shears moments, axial forces and transfer forces, that are to be resisted by the individual members and their connections, sufficient to allow the fabricator to select or complete connection details..."

This statement is most remarkable for what it does not require. It does not require the fabricator to be provided with all of the loads, or even loads that satisfy equilibrium. It merely requires that *sufficient* information be provided. It should also be noted that the term transfer force is not defined in the glossary for either the AISC Code of Standard Practice or the AISC Specification. In fact a survey of steel design handbooks will demonstrate that the term is neither ubiquitous nor well-understood. It is therefore useful to begin any discussion of transfer forces with a definition. A possible definition for a transfer force is a force that must be transferred from one element to another through connection elements and whose magnitude and direction cannot be ascertained from the maximum member end forces.

51

**Transfer Forces**

normal transfer is only a secondary concern. However, the magnitude of the vertical load that must be delivered to the column is unclear. Again, either statically consistent loadings.

**D.2. PRESENTATION OF TRANSFER FORCES IN DESIGN DOCUMENTS**

There are two possible methods that can be used to satisfy the AISC *Code of Standard Practice* requirement that sufficient load information be provided to complete the connection design. The first method involves providing a matrix of statically consistent load combinations that can be used to determine the required transfer force. An example of this type of presentation based on Table D-1 is shown in Figure D-3.

The procedure for generating such a matrix can be described as follows:

1. Define the assumed connection configuration.
2. Determine the load combinations that produce the maximum tension and maximum compression end forces for each member framing into a joint. Additionally, determine the load combinations that produce the maximum tension and maximum compression transfer forces.
3. For each load combination found in Step 1, give the axial forces in all members associated with that load combination so that joint equilibrium is provided for each. The maximum number of load cases will be equal to  $2(n-1)$ , where  $n$  is the number of members framing into the joint.

Possible advantages of this approach are as follows:

- Joint equilibrium is always provided for each load case, making the load paths very clear.

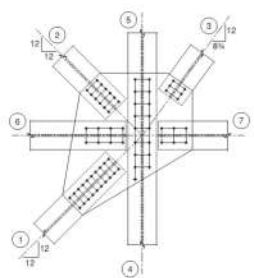



Fig. D-2. Alternate connection configuration.

584 / VERTICAL BRACING CONNECTIONS—ANALYSIS AND DESIGN / AISC DESIGN GUIDE 29



52

### Transfer Forces

All connections transfer forces, but...

The term "transfer forces" as used and described in DG 29, Appendix "D" refers to framing configurations where forces are transferred through nodes where multiple members converge, and where forces do not resolve if only maximum member forces are provided by the EOR in each member.

The most economical connections are achieved when the EOR provides forces in all members for various load combinations. (More work for EOR)

Heavier connections result when only maximum forces in each member are provided. (Less work for EOR)

(To be discussed further in Session #5 – "Vertical Bracing Connections")



53

### Understand what is not connection design



54

### Understand what is not connection design

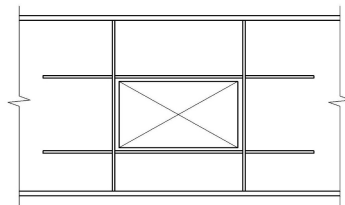

Do not delegate design of beam web reinforcing around openings

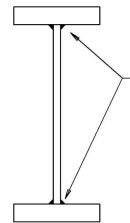

Do not delegate design of plate girder welds



55

### Show the reactions

Overly conservative connection design criteria do not make buildings safer



56



Using Table 3-6 can result in specification of undersized connection strength requirements

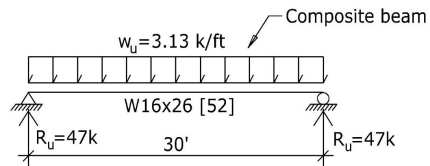

- From Table 3-6, 15th Edition AISC Manual maximum uniform load capacity for W16x26 (LRFD) is 44.2k for L=30'
- Connection requirement on contract documents: Design connections for 150% of the reaction from the uniform load capacity of the beams from Table 3-6 ( $0.75 \times 44.2k = 33k$ )
- Specified connection strength based on the arbitrary 1.5 x Table 3-6 value is 42% less than required for actual loads. ← Too low!!



61

Using Table 3-6 can result in specification of undersized connection strength requirements

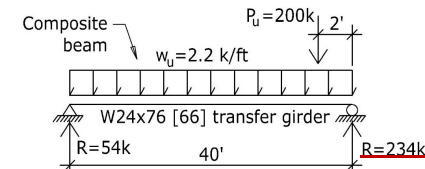

- From Table 3-6, 15th Edition AISC Manual maximum uniform load capacity for W24x76 (LRFD) is 150k for L=40'
- Connection requirement on contract documents: Design connections for 150% of the reaction from the uniform load capacity of the beams from Table 3-6 ( $0.75 \times 150k = 113k$ )
- Actual reaction at right end is more than twice as big as specified connection strength!



62

The right way...

Show member shear reactions on framing plans, moment connection design moments, and axial loads in braces and truss members.



63

**Do not mandate connection design requirements more stringent than required by the Building Code and AISC 360**



64

**Examples of arbitrary (and unnecessary) connection requirements**

- “All bolts shall be slip-critical”
- “All connections shall be designed for the full strength of the member”
- “All holes shall be standard sized holes”
- “Single-sided shear connections are prohibited”



65

**Use R=3 (where permitted)**



66

**Limit tension yield strength ratio to 0.75  
for tension members with bolted  
connections with  $A_e > 0.75A_g$**



67

**Limit tension yield strength ratio to 0.75 for tension members with bolted connections\***

(\*Provided that  $A_e > 0.75A_g$ )\*\*

(\*\* The use of  $A_e = 0.75A_g$  in the AISC Manual Part 5 tension tables is only *an approximation* for bolted connections)

$$\text{Tension yield strength ratio} = \frac{\text{Required strength}}{\text{Tension yield strength}}$$



68

### Limit tension yield strength ratio to 0.75

#### D2. TENSILE STRENGTH

The design tensile strength,  $\phi_t P_n$ , and the allowable tensile strength,  $P_n/\Omega_t$ , of tension members shall be the lower value obtained according to the limit states of tensile yielding in the gross section and tensile rupture in the net section.

(a) For tensile yielding in the gross section:

$$P_n = F_y A_g \quad (D2-1)$$

$$\phi_t = 0.90 \text{ (LRFD)} \quad \Omega_t = 1.67 \text{ (ASD)}$$

(b) For tensile rupture in the net section:

$$P_n = F_u A_e \quad (D2-2)$$

$$\phi_t = 0.75 \text{ (LRFD)} \quad \Omega_t = 2.00 \text{ (ASD)}$$



### Limit tension yield strength ratio to 0.75 for tension members with bolted connections\*

(\*Provided that  $A_e > 0.75A_g$ )

(Reduces likelihood that member reinforcement will be required at the net section at connections.)

Steel	Max suggested tension yield strength ratio for connections when $A_e \geq 0.75A_g$
A36	1.0
A992	0.81 (use 0.75)
A913 (65)	0.77 (use 0.75)
A913 (70)	0.80 (use 0.75)



### Limit tension member strength ratio

ASTM A36:

$$\begin{aligned} F_y &= 36 \text{ ksi} \\ F_u &= 58 \text{ ksi} \end{aligned} \quad \frac{A_e}{A_g} = 1.2 \frac{F_y}{F_u} = 1.2 \frac{36}{58} = 0.75$$

ASTM A992:

$$\begin{aligned} F_y &= 50 \text{ ksi} \\ F_u &= 65 \text{ ksi} \end{aligned} \quad \frac{A_e}{A_g} = 1.2 \frac{F_y}{F_u} = 1.2 \frac{50}{65} = 0.92$$

ASTM A913 Grade 65:

$$\begin{aligned} F_y &= 65 \text{ ksi} \\ F_u &= 80 \text{ ksi} \end{aligned} \quad \frac{A_e}{A_g} = 1.2 \frac{F_y}{F_u} = 1.2 \frac{65}{80} = 0.98$$

$A_e/A_g$  ratios below which tension rupture strength < tension yield strength



### Limit tension member strength ratio

$F_y = 50 \text{ ksi}$   
 $F_u = 65 \text{ ksi}$

Table 5-1 (continued)  
Available Strength in  
Axial Tension  
W-Shapes

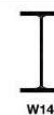

Shape	Gross Area, $A_g$ in. <sup>2</sup>	$A_e = 0.75A_g$ in. <sup>2</sup>	Yielding kips		Rupture kips	
			$P_n/\Omega_t$	$\phi_t P_n$	$P_n/\Omega_t$	$\phi_t P_n$
			ASD	LRFD	ASD	LRFD
W14x873 <sup>#</sup>	257	193	7690	11600	6270	9410
x808 <sup>#</sup>	238	179	7130	10700	5820	8730
x730 <sup>#</sup>	215	161	6440	9680	5230	7850
x665 <sup>#</sup>	196	147	5870	8820	4780	7170
x605 <sup>#</sup>	178	134	5330	8010	4360	6530
x550 <sup>#</sup>	162	122	4850	7290	3970	5950
x500 <sup>#</sup>	147	110	4400	6620	3580	5360
x455 <sup>#</sup>	134	101	4010	6030	3280	4920
x426 <sup>#</sup>	125	93.8	3740	5630	3050	4570
x398 <sup>#</sup>	117	87.8	3500	5270	2850	4280



**This may happen when tension rupture strength (and other things) are not considered during design...**

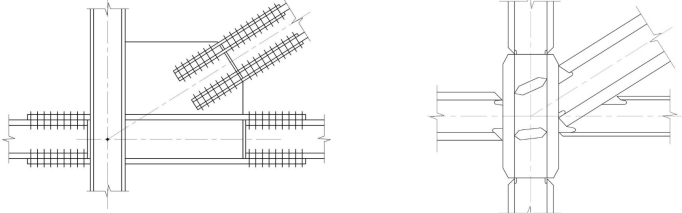

Concept connection detail ignoring tension rupture strength (as well as other limit states)

Required connection detail



73

**Think about connection economy**

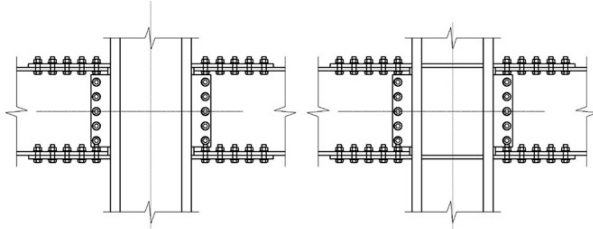

- “Least weight” does not always equate with “least cost”
- Stiffener plates and web doubler plates are expensive



74

**Think about connection economy**

How expensive are stiffeners & doublers?

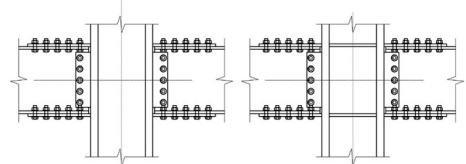

References,

1. “Connections: Art, Science, and Information in the Quest for Economy and Safety”  
Dr. William Thornton, Engineering Journal, Fourth Quarter 1995
2. “Stiffeners, Doublers, and Web Plates -- Oh my!” , Carol Drucker, SE, PE, Peng, AISC Webinar, July 12, 2018 (Available on AISC website)



75

**Think about constructability and connection “designability”**



76

### Think about constructability and connection “designability”

#### Connection designability

- How will the connections be designed and detailed?
- Are the connections “designable”?

#### Constructability

- Will the connections be easy and economical to fabricate?
- Will they be easy to install in the field?



77

### Connection “designability”

- EOR has options during design
- Configure the framing to improve the “designability” of connections



78

### Connection “designability”

- Least weight ≠ least cost with HSS trusses.
- Think about the connections when selecting HSS truss member sizes. (See Part 13 of 15<sup>th</sup> Edition AISC Steel Construction Manual)

Demand-to-capacity ratio → (see next slide)

TABLE K3.2 (continued)  
Available Strengths of Rectangular  
HSS-to-HSS Truss Connections

Connection Type	Connection Available Axial Strength
Overlapped K Connections	<p>Limit State: Local Yielding of Branch/Branches due to Uneven Load Distribution  <math>\phi = 0.95</math> (LRFD); <math>\phi = 1.00</math> (ASD)</p> <p>When 20% ≤ <math>C_1</math> ≤ 50%  <math>R_n = F_u A_n \left[ \frac{C_1}{L_{br}} (2H_b - A_{br}) + R_{br} + R_{bf} \right]</math> (K3-10)</p> <p>When 50% ≤ <math>C_1</math> ≤ 80%  <math>R_n = F_u A_n (2H_b - 4t_b + R_{br} + R_{bf})</math> (K3-11)</p> <p>When 80% ≤ <math>C_1</math> ≤ 100%  <math>R_n = F_u A_n (2H_b - 4t_b + R_{br})</math> (K3-12)</p> <p>Note that the force arrows shown for overlapped K connections may be reversed, and control number identification.</p> <p>Subscript (s) refers to the overlapping branch.                      Subscript (f) refers to the connecting branch.</p> $R_{br} = R_n \left( \frac{F_{u,br}}{F_u A_n} \right)$ (K3-13)
Functions	
$U_1 = 1$ for gapped connecting surface in tension $= 1.3 - 0.4 \frac{L_{br}}{H_b} < 1.0$	(K3-14)
for chord connecting surface in compression, for T, Y, and cross-connections $= 1.3 - 0.4 \frac{L_{br}}{H_b} < 1.0$	(K3-15)
for chord connecting surface in compression, for gapped K connections	(K3-16)
$\phi = \begin{cases} \phi_t & \text{for } P_n \text{ and } M_n \\ \phi_c & \text{for } P_n \text{ and } M_n \end{cases}$	(K3-17)
$F_u = \begin{cases} F_u & \text{for LRFD} \\ F_u & \text{for ASD} \end{cases}$	(K3-18)
$F_u = \begin{cases} F_u & \text{for LRFD} \\ F_u & \text{for ASD} \end{cases}$	(K3-19)
$F_u = \begin{cases} F_u & \text{for LRFD} \\ F_u & \text{for ASD} \end{cases}$	(K3-20)



79

### 15<sup>th</sup> Edition AISC Steel Construction Manual, pages 13-17 & 13-18,

#### Design Considerations for HSS-to-HSS Truss Connections

HSS member sizes are often critical in connection design. Connection design, including weld requirements in AISC Specification Section K5, should be considered during main member selection as the connection limit states may force an increase in the member wall thickness over the main member design thickness. Compression chords should be sized such that the demand-to-capacity ratio is considerably less than one, such that the effects of web members do not cause the face of the chord to be overstressed. At initial design, Packer et al. (2010b) recommends that chords have thick walls rather than thin walls; web members have thin walls rather than thick walls; web members be wide relative to the chord members, but still able to sit on the “flat” face of the chord section if possible; and gap connections (for K and N situations) are preferred to overlap connections because the members are easier to prepare, fit and weld. Where a gap is provided between the web members, the gap should be equal to or greater than the sum of the thicknesses of the web members to facilitate welding. Where web members are overlapped, the thicker web member should run through to the chord, and the overlap length (measured along the connecting face of the



80



### Connection "designability"

Steep skewed connections with large reactions are difficult to design

450k

"Designable" connections

PROBLEM      SOLUTION

Head off steeply skewed connections

81

### Connection "designability"

Skewed braced frame connections are complicated and expensive

Braced frame

Braced frame

Orient columns in braced frames square

82

### Connection constructability

DOUBLE ANGLE CONN. w/ 1/2" THK ANGLES & 10 ROWS OF 7/8" Ø A490N BOLTS

1" PL. w/ (20) 1" Ø A490N BOLTS

1" PL. (ASTM A572, GR 50) w/ (40) 1" Ø A490N BOLTS

NO WELDS

FILLET WELDS

W36X150, Vu=490k

CIP WELD

Orient framing so that heavily loaded members frame square to the columns (preferably square to column flanges)

83

### Connection "designability"

Configure framing so that no more than one beam frames to any one side of a column.

84

### Connection "designability"

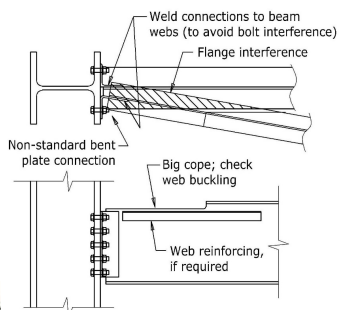

Weld connections to beam webs (to avoid bolt interference)  
Flange interference  
Non-standard bent plate connection  
Big cope; check web buckling  
Web reinforcing, if required

Configure framing so that no more than one beam frames to any one side of a column.



85

### Connection "designability"

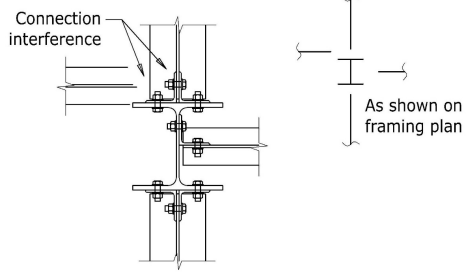

Connection interference  
As shown on framing plan

Be aware of connection interference where beams are slightly offset from columns.



86

### Connection "designability"

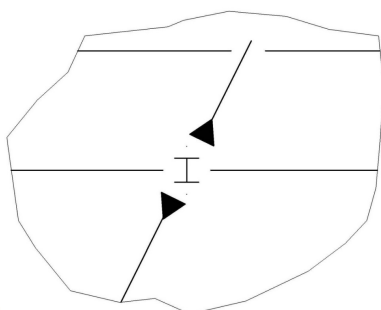

Avoid skewed beam-to-column moment connections



87

### Kinked connections

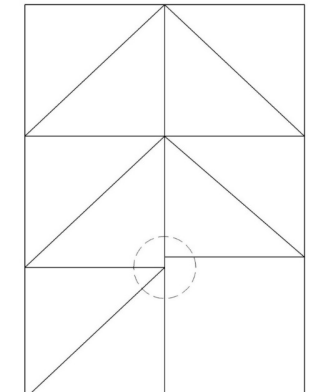

88

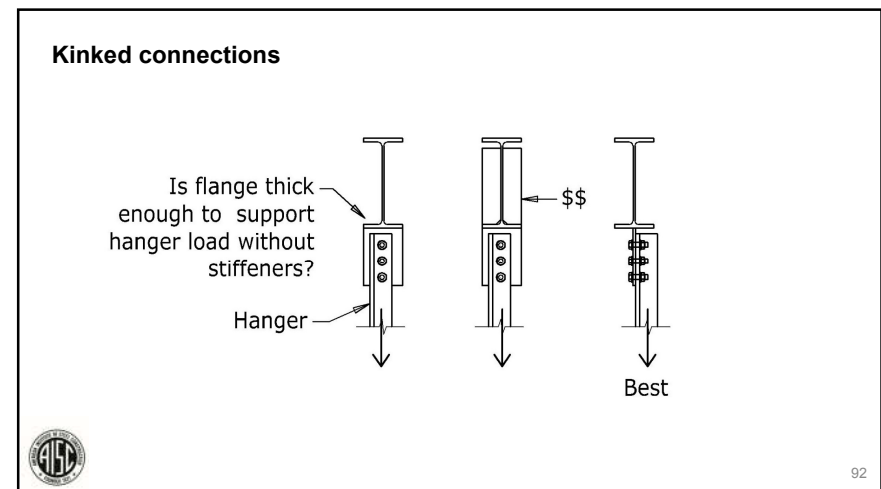
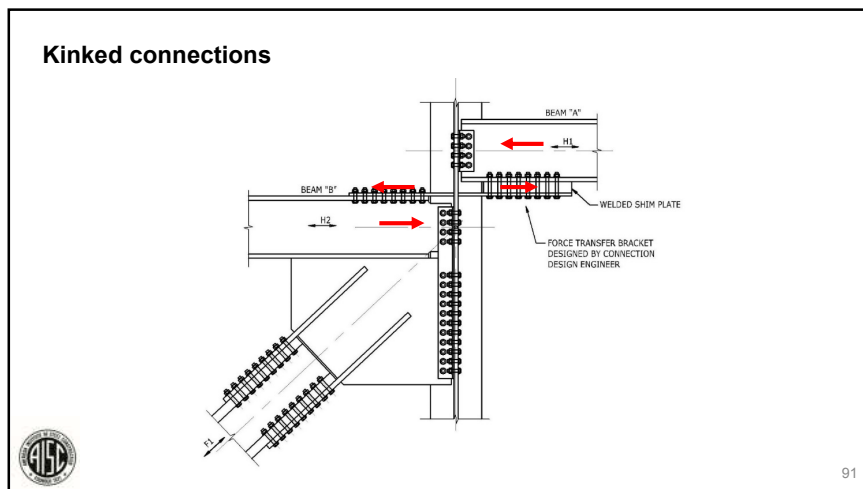
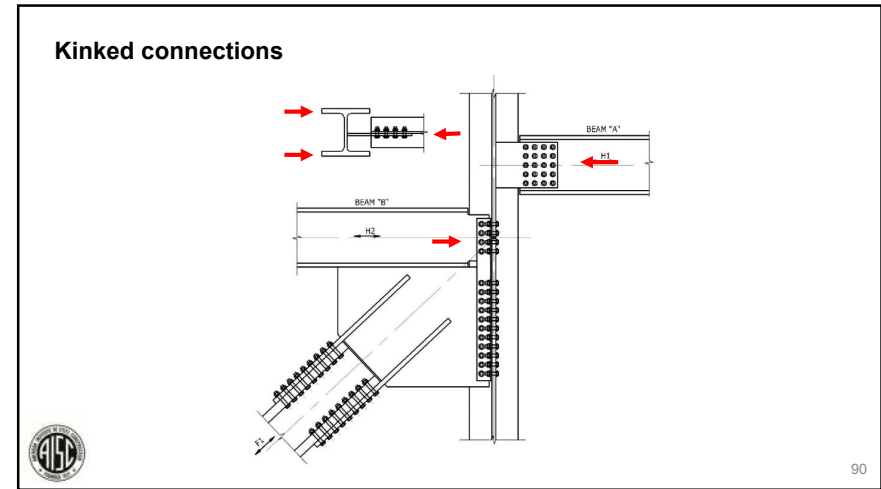
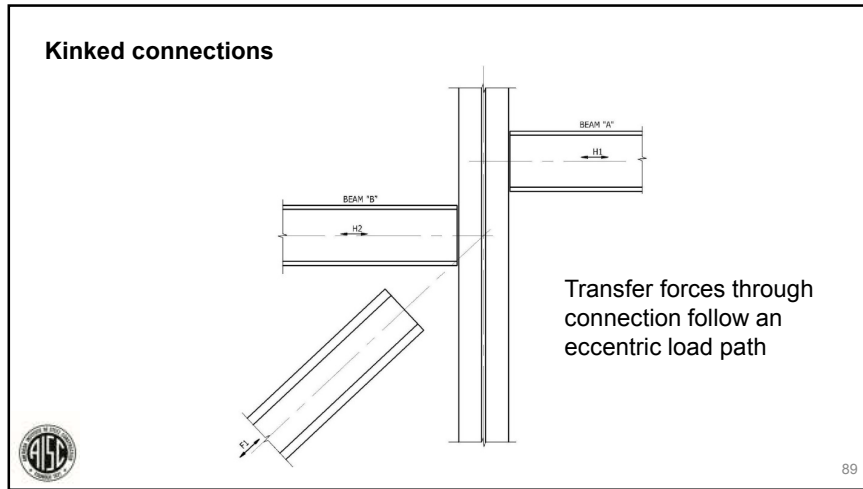

### Kinked connections

#### SECONDARY STRESSES IN FRAMED STRUCTURES

BY E. W. PITTMAN.\*

Secondary stresses in framed structures are due, primarily, to faulty details. Attention will be directed to some of the more common faults and inconsistencies that are of frequent occurrence in structural details, and an effort made to illustrate their effects upon the strength of the structures.

In the general design of an articulated structure, such as a bridge or roof truss, it is assumed that the axes of the various members meeting at a joint are concurrent; that is, intersecting at a common point, and that they are free to rotate about this point as elastic deformation takes place.

In the case of a pin connected truss, the assumed conditions are usually neglected, but in the case of a riveted truss

\* Chief Engineer, Pittsburgh Steel Construction Co.  
Presented before the Structural Section, January 5, 1909. Address of retiring Chairman.



93

### Kinked connections

PITTMAN—SECONDARY STRESSES IN FRAMED STRUCTURES . 81

current, but the rivet connection through the chord is eccentric to the intersection of the lines of stress, and a bending moment results. The proper construction of this joint is as shown in Fig. 4.

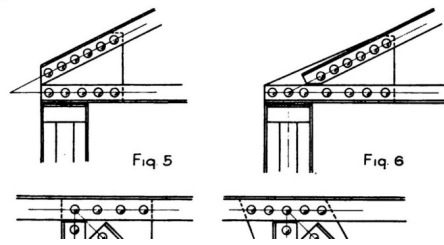

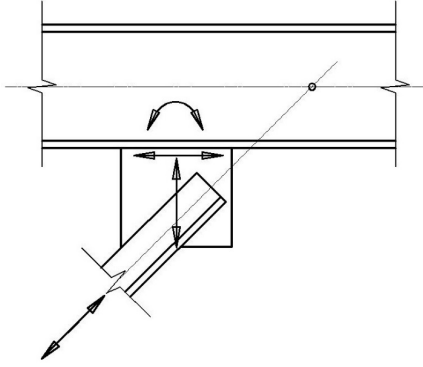

Fig 5 Fig 6



94

### Kinked connections



95



### Kinked connections

Preferred detail (no secondary stresses in gusset and weld)

97

### Connection constructability

3 SKEWED CONNECTIONS  
1 SQUARE CONNECTION

3 SQUARE CONNECTIONS  
1 SKEWED CONNECTION

Square connections cost less than skewed connections.  
Orient columns to minimize skewed connections.

98

### Connection constructability

Increase beam depth to avoid web reinforcement

Web reinforcing plate

Use deeper beam to eliminate web reinforcing plate

Angle if required to prevent web buckling

(If web reinforcing is required a less expensive solution may be to use a deeper beam)

Possible situations requiring web reinforcing:

- Large copes / heavy reactions
- High beams / low girders
- Skewed beams with long copes

99

### Connection constructability

3 1/2"

Min. gage for installation of 7/8"Ø bolts through flanges

Min. recommended flange width to install bolts through flange = 6"  
(Don't forget to check net section.)

(End-plate moment connections are possible solutions to narrow flange moment connections to columns.)

100

**Allow fabricators to suggest  
alternative connection details**



101

**Summary**

1. Understand AISC 303-16 rules for delegating connection design
2. Provide “**concept connection details**” (details that work)
3. Provide bidding quantities where member reinforcement at connections is required
4. Consider **constructability** and “**connection designability**”
5. Look for (and detail) all unusual connections
6. Watch out for “**kinked connections**”
7. Show reactions, axial forces, and moments in moment connections
8. Provide **transfer force** connection design requirements



102

**Summary**

9. Think about **connection economy** when framing the structure
10. Do not mandate connection design requirements in excess of the building code
11. Use R=3 for seismic design (when permitted)
12. Limit tension yield strength ratio to 0.75 in tension members (provided that  $A_e > 0.75 \times A_g$ )
13. Consider fabricator suggested alternative connection details
14. Issue complete and well-documented drawings. Good communication of design intent requires good drawings (Don't kick the can down the road.)
15. **Always** be thinking about the connections when you frame the structure - even when (*especially when*) delegating connection design.



103

**Thank you!**

AISC | Questions?



**Smarter.  
Stronger.  
Steel.**

## Individual Session Registrants

### CEU / PDH Certificates

- You will receive an email on how to report attendance from: [registration@aisc.org](mailto:registration@aisc.org).
- Be on the lookout: Check your spam filter! Check your junk folder!
- Completely fill out online form. Don't forget to check the boxes next to each attendee's name!



## Individual Session Registrants

### CEU / PDH Certificates

- Reporting site (URL will be provided in the forthcoming email).
- Username: Same as AISC website username.
- Password: Same as AISC website password.



## 8-Session Registrants

### CEU / PDH Certificates

One certificate will be issued at the conclusion of all 8 sessions.



## 8-Session Registrants

### Access to the quiz

Information for accessing the quiz will be emailed to you by Wednesday. It will contain a link to access the quiz. EMAIL COMES FROM [NIGHTSCHOOL@AISC.ORG](mailto:NIGHTSCHOOL@AISC.ORG).

### Quiz and attendance records

Posted Tuesday mornings. [www.aisc.org/nightschool](http://www.aisc.org/nightschool) -- Click on Current Course Details.

### Reasons for quiz

- EEU – You must take all quizzes and the final exam to receive EEU.
- CEUs/PDHs – If you watch a recorded session, you must pass quiz for CEUs/PDHs.
- REINFORCEMENT – Reinforce what you learn tonight. Get more out of the course.

*Note: If you attend the live presentation, you do not have to take the quizzes to receive CEUs/PDHs*



## 8-Session Registrants

### Access to the recording

Information for accessing the recording will be emailed to you by Wednesday. The recording will be available for three weeks. (For 8-session registrants only.) EMAIL COMES FROM [NIGHTSCHOOL@AISC.ORG](mailto:NIGHTSCHOOL@AISC.ORG).

### CEUs / PDHs via recording

If you watch a recorded session, you must take *and pass* the quiz for CEUs/PDHs.



## 8-Session Registrants

### Night School Resources

Find all your handouts, quizzes and quiz scores, recording access, and attendance information all in one place!



## 8-Session Registrants

### Night School Resources

Go to [www.aisc.org](http://www.aisc.org) and sign in.



#### Login

If you're an existing customer, please enter your username and password.

##### USERNAME

Enter your username

##### PASSWORD

Enter your password

Remember Me

##### DON'T HAVE AN ACCOUNT?

My AISC allows you to access Engineering Journal articles and Design Guides you have downloaded from the bookstore.

[REGISTER NOW](#)



## 8-Session Registrants

### Night School Resources

Go to [www.aisc.org](http://www.aisc.org) and sign in.

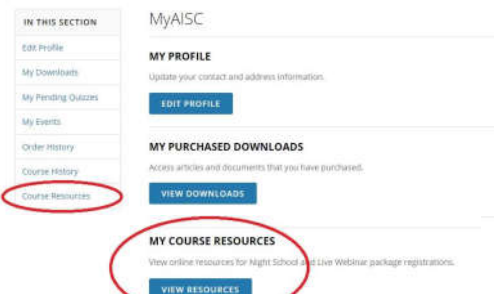

## 8-Session Registrants

### Night School Resources

Course Resources

Event	Start Date
NS 13 8-Session Package Night School 13 - Design of Industrial Buildings	3/16/2017 7:00:00 PM
NS 14 8-Session Package Night School 14 - Fundamentals of Stability	6/5/2017 7:00:00 PM

## 8-Session Registrants

### Night School Resources

Night School 13: Design of Industrial Buildings

#### 8-SESSION PACKAGE RESOURCES

Event	Date	Handouts	Video	Quiz	Attendance
NS13 - Design Criteria	1/30/2017 7:00:00 PM	<a href="#">Handouts</a>	<a href="#">Video</a>	Pass Score: 33	Pending
NS13 - Economic Considerations	2/6/2017 7:00:00 PM	<a href="#">Handouts</a>	<a href="#">Video</a>	Available 02/06/2017 5pm EST	Pending
NS13 - Lateral Load Systems and Details	2/13/2017 7:00:00 PM	<a href="#">Handouts</a>	<a href="#">Video</a>	Available 02/13/2017 5pm EST	Pending
NS13 - Preliminary Design Procedures	2/20/2017 7:00:00 PM	<a href="#">Handouts</a>	<a href="#">Video</a>	Available 03/02/2017 5pm EST	Pending
NS13 - Crane Girders Design and Frame Analysis	3/6/2017 7:00:00 PM	<a href="#">Handouts</a>	<a href="#">Video</a>	Available 03/06/2017 5pm EST	Pending
NS13 - Frame Member and Connection Design	3/13/2017 7:00:00 PM	<a href="#">Handouts</a>	<a href="#">Video</a>	Available 03/13/2017 5pm EST	Pending
NS13 - Transfer Crane Girder to Longitudinal Brag Bracing Detail	3/27/2017 7:00:00 PM	<a href="#">Handouts</a>	<a href="#">Video</a>	Available 03/26/2017 5pm EST	Pending

## 8-Session Registrants

### Night School Resources

- Weekly “quiz and recording” email.
- Weekly updates of the master quiz and attendance record, found at [www.aisc.org/nightschool19](http://www.aisc.org/nightschool19). Scroll down to Quiz and Attendance records.
  - Updated on Tuesday mornings.

## 8-Session Registrants

### Night School Resources

- Webinar connection information
  - Found in your registration confirmation / receipt
  - Reminder email sent out Monday mornings
- Links to handouts also found here

