

Thank you for joining our live webinar today.

We will begin shortly.
Please standby. Thank you.

Need Help?
Call ReadyTalk Support:
800.843.9166

AISC Night School



Connection Design

Tips, Tricks, and Lessons Learned



**Smarter.
Stronger.
Steel.**

AISC Night School

Audio Options

Today's audio will be broadcast through the internet.

Alternatively, to hear the audio through the phone, dial:

(866)-519-2796
Passcode: 324420



**Smarter.
Stronger.
Steel.**





Today's live webinar will begin shortly. Please stand by.

As a reminder, all lines have been muted. Please type any questions or comments through the chat feature on the left portion of your screen.

Today's audio will be broadcast through the internet.
Alternatively, to hear the audio through the phone, dial:

(866)-519-2796
Passcode: 324420



**Smarter.
Stronger.
Steel.**



AIA Credit

AISC is a Registered Provider with The American Institute of Architects Continuing Education Systems (AIA/CES). Credit(s) earned on completion of this program will be reported to AIA/CES for AIA members. Certificates of Completion for both AIA members and non-AIA members are available upon request.

This program is registered with AIA/CES for continuing professional education. As such, it does not include content that may be deemed or construed to be an approval or endorsement by the AIA of any material of construction or any method or manner of handling, using, distributing, or dealing in any material or product.

Questions related to specific materials, methods, and services will be addressed at the conclusion of this presentation.



**Smarter.
Stronger.
Steel.**



Copyright Materials

This presentation is protected by US and International Copyright laws. Reproduction, distribution, display and use of the presentation without written permission of AISC is prohibited.

© The American Institute of Steel Construction 2019

The information presented herein is based on recognized engineering principles and is for general information only. While it is believed to be accurate, this information should not be applied to any specific application without competent professional examination and verification by a licensed professional engineer. Anyone making use of this information assumes all liability arising from such use.



Smarter.
Stronger.
Steel.



Course Description

19.5 Vertical Bracing Connections March 11, 2019

Don't waste time showing too much information that isn't used or that can unnecessarily complicate your design. This session will include tips for successful delegated vertical bracing design and what information should be included on drawings, which will help you limit RFIs and resubmittals.



Smarter.
Stronger.
Steel.





Learning Objectives

- Identify detailing notes, for vertical bracing connections, that can lead to challenges for the connection engineer.
- Explain how to analyze and account for transfer forces in braced-frame buildings.
- Describe the various analysis methods that can be applied to the design of corner bracing connections.
- List issues to look for when reviewing vertical bracing connection designs.



Smarter.
Stronger.
Steel.

Night School 19 Connection Design: Tips, Tricks, and Lessons Learned

Session 5: Vertical Bracing Connections
March 11, 2019



Carol Drucker, SE, PE, PEng
Principal

dzse
Drucker Zajdel Structural Engineers, Inc.
Chicago, IL



Smarter.
Stronger.
Steel.



Items Covered

- Load path
- Information needed for delegated design
- Information not necessarily needed
- When to expect RFIs
- First steps to design
- Corner, Chevron, Base, and Column Splices
- Seismic design
- Reviewing calculations



Session 5: Vertical Bracing Connections

9

Systems to Resist Lateral Load

- Concrete Shear Walls
- **Braced Frames**
- Moment Frames
- Dual Systems

Advantage

- Rigid
- Typically more cost effective than moment frames

Disadvantage

- May interfere with openings



Photo by Jon Miller



Session 5: Vertical Bracing Connections

10

Load Path For Wind

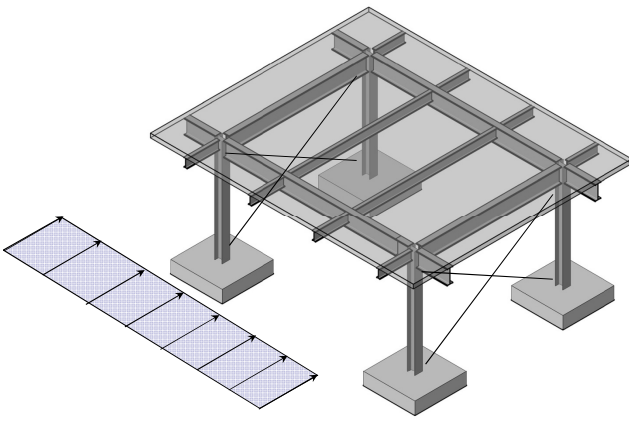

- Wind on facade
- Facade to structure (e.g. beams or diaphragms)
- Diaphragms to lateral force resisting system (LFRS)
- LFRS to foundations



Session 5: Vertical Bracing Connections

11

Load Path For Wind

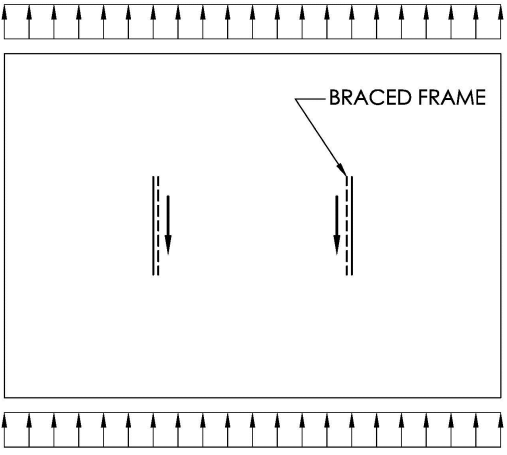

- Wind on facade
- Facade to structure (e.g. beams or diaphragms)
- Diaphragms to LFRS
- LFRS to foundations

WIND LOAD



Session 5: Vertical Bracing Connections

12



Load Path For Wind

BRACED FRAME

DRAG FORCE

WIND LOAD



Session 5: Vertical Bracing Connections

13

Vertical Bracing

Vertical Bracing



Session 5: Vertical Bracing Connections

14



Vertical Bracing – Show Corner, Base, Chevron, Splice

- Corner Bracing
- Chevron
- Base
- Splices

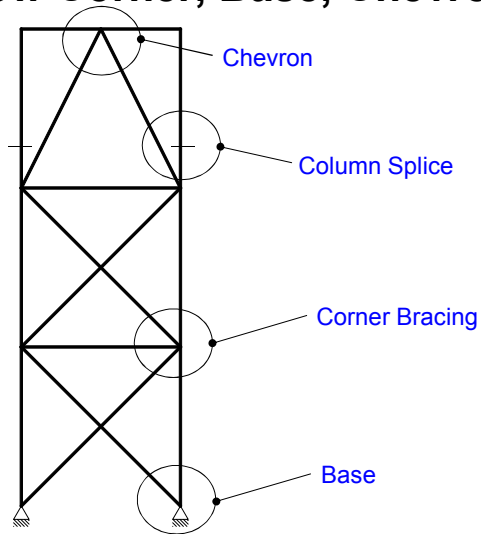

Vertical Bracing - Plans

- Dashed lines for brace
- Brace elevation references
- Transfer forces

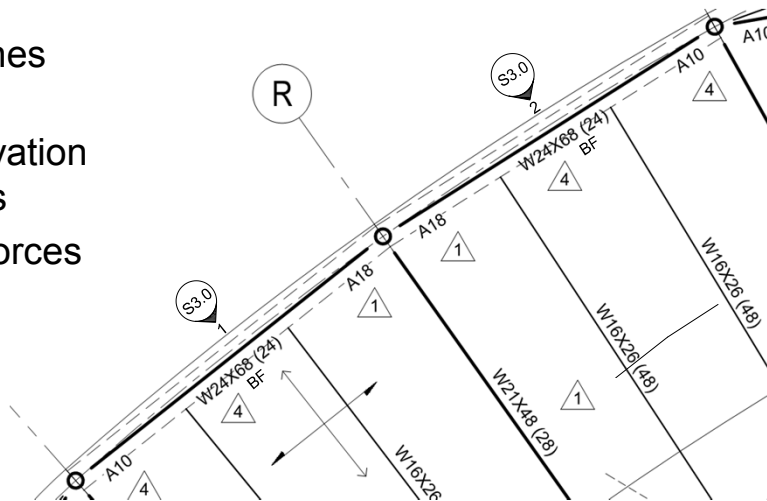

Vertical Bracing Elevations

- Typically shown
 - Elevations
 - Brace size
 - Brace force
 - Grid locations
- Helpful information
 - Beam size
 - Column size
 - Transfer forces
 - Bay length
 - Column orientation

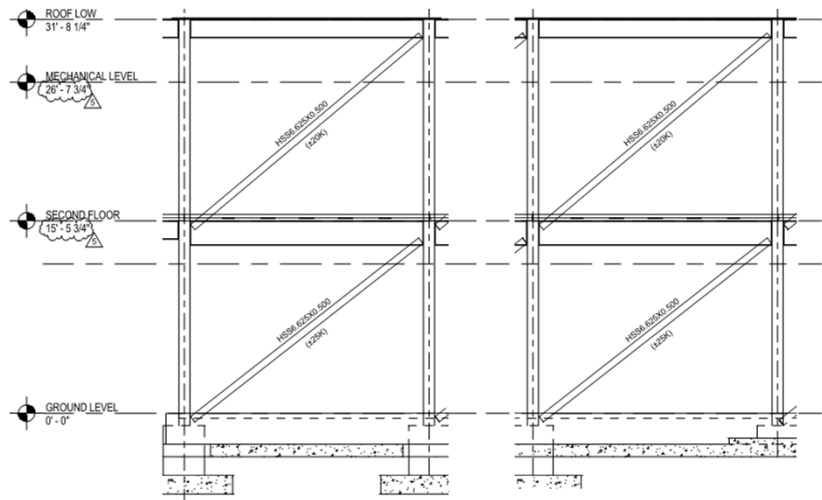

Session 5: Vertical Bracing Connections

17

Vertical Bracing Elevations

- Corner Bracing
 - Map transfer force
 - Map gravity loads
 - Map beam sizes
 - Map column sizes

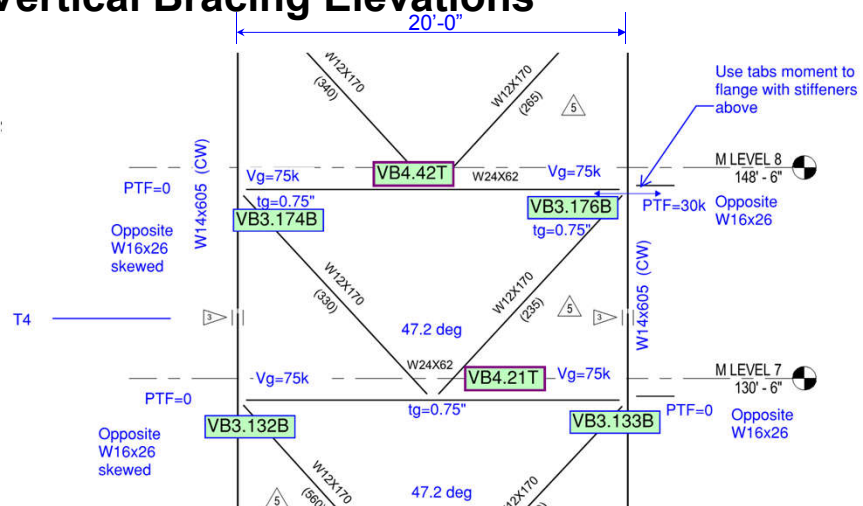

Session 5: Vertical Bracing Connections

18



Vertical Bracing – Items to Show

- Notes

All connections, unless specifically designated as being completely designed on the structural drawings, shall be designed and detailed by a structural engineer licensed in the state where the project is located.

Schematic detail. Fabricator to design actual connection based on required loading

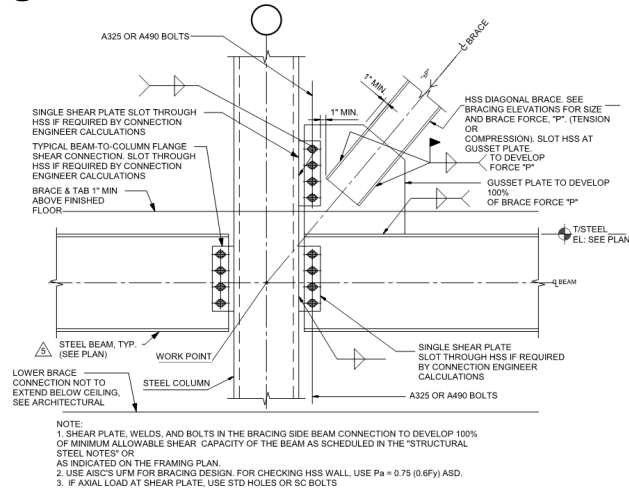

5 TYP. BRACING DETAIL AT HSS COL
 SCALE: NOT TO SCALE



Vertical Bracing – Items to Show

- Architectural requirements

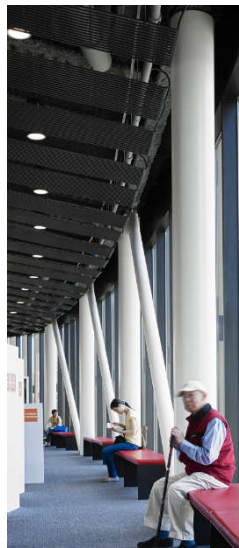

BRACE & TAB 1" MIN ABOVE FINISHED FLOOR

LOWER BRACE CONNECTION NOT TO EXTEND BELOW CEILING, SEE ARCHITECTURAL

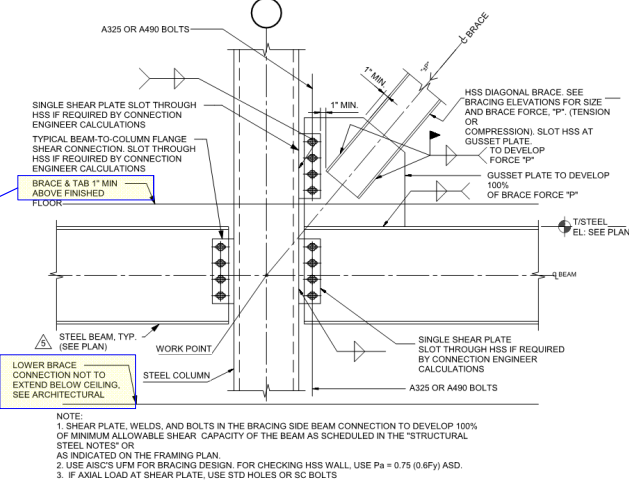

5 TYP. BRACING DETAIL AT HSS COL
 SCALE: NOT TO SCALE

Photo by Jon Miller



Vertical Bracing – Items to Show

- Information needed for design

SINGLE SHEAR PLATE SLOT THROUGH HSS IF REQUIRED BY CONNECTION ENGINEER CALCULATIONS

FOR CHECKING HSS WALL, USE $P_a = 0.75 (0.6F_y)$ ASD

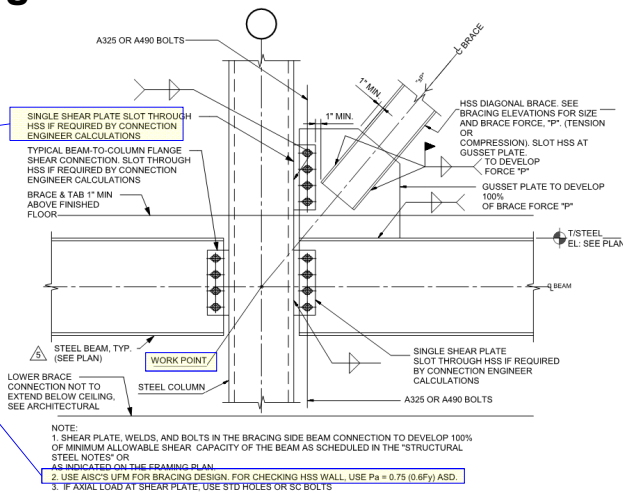

5 TYP. BRACING DETAIL AT HSS COL

SCALE: NOT TO SCALE



Code of Standard Practice

– 2016 COSP (303-16) Section 3.1.1 and Section 3.1.2

- » Option 3: in the structural *design documents* or *specifications*, the *connection* shall be designated to be designed by a licensed engineer working for the *fabricator*
- » Options 3A and 3B: More applicable to moment connection design but could apply at vertical bracing (mainly at chevron connections)
 - » Option 3A: Member reinforcement at connections shall be designed by owners' designated representative for design and shown in the structural design documents
 - » Option 3B: Member reinforcement at connections is delegated design, but the quantities and conceptual configurations shall be provided and relied upon for bidding purposes. If no quantities or conceptual configurations are shown, member reinforcement at *connections* will not be included in the bid.



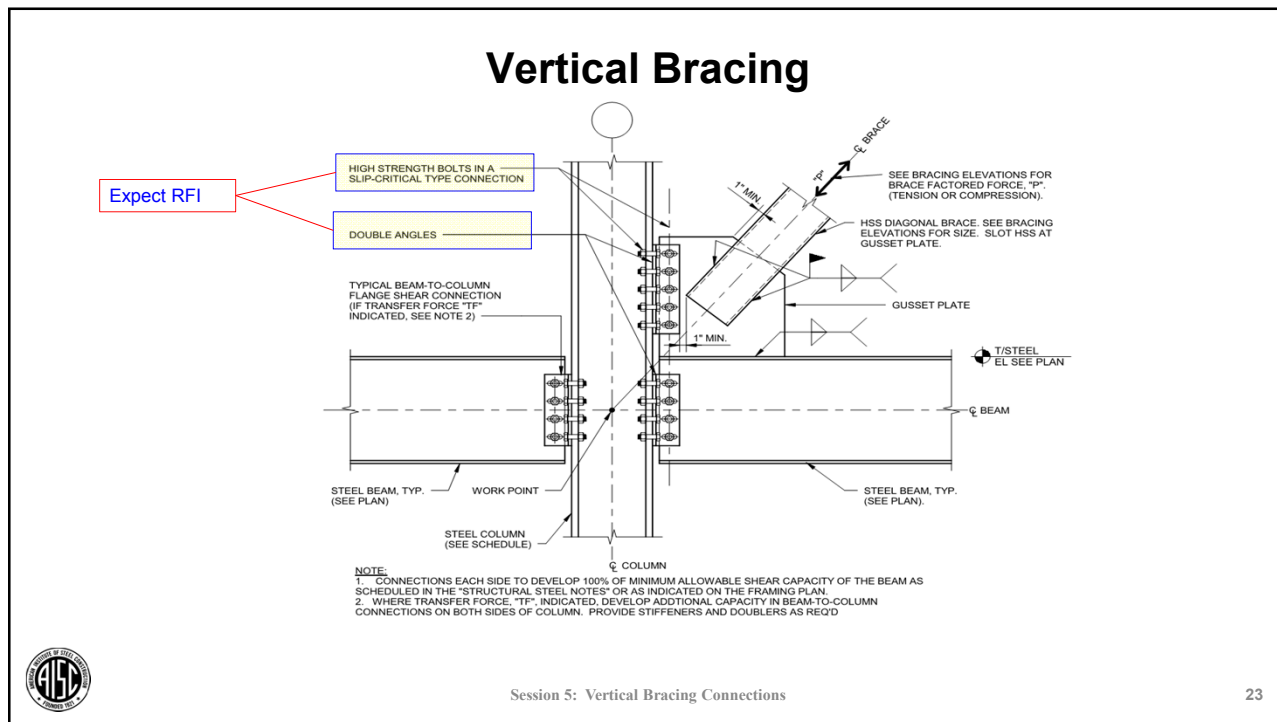

Vertical Bracing

- SC Bolt Requirements given in RCSC Specification

4.3. Slip-Critical Joints
Slip-critical joints are required in the following applications involving shear or combined shear and tension:

- (1) *Joints* that are subject to fatigue load with reversal of the loading direction;
- (2) *Joints* that utilize oversized holes;
- (3) *Joints* that utilize slotted holes, except those with applied load approximately normal (within 80 to 100 degrees) to the direction of the long dimension of the slot; and,
- (4) *Joints* in which slip at the *faying surfaces* would be detrimental to the performance of the structure.

Bolts in *slip-critical joints* shall be designed in accordance with the applicable provisions of Sections 5.1, 5.2, 5.3, 5.4 and 5.5, installed in accordance with Section 8.2 and inspected in accordance with Section 9.3.

Session 5: Vertical Bracing Connections 24



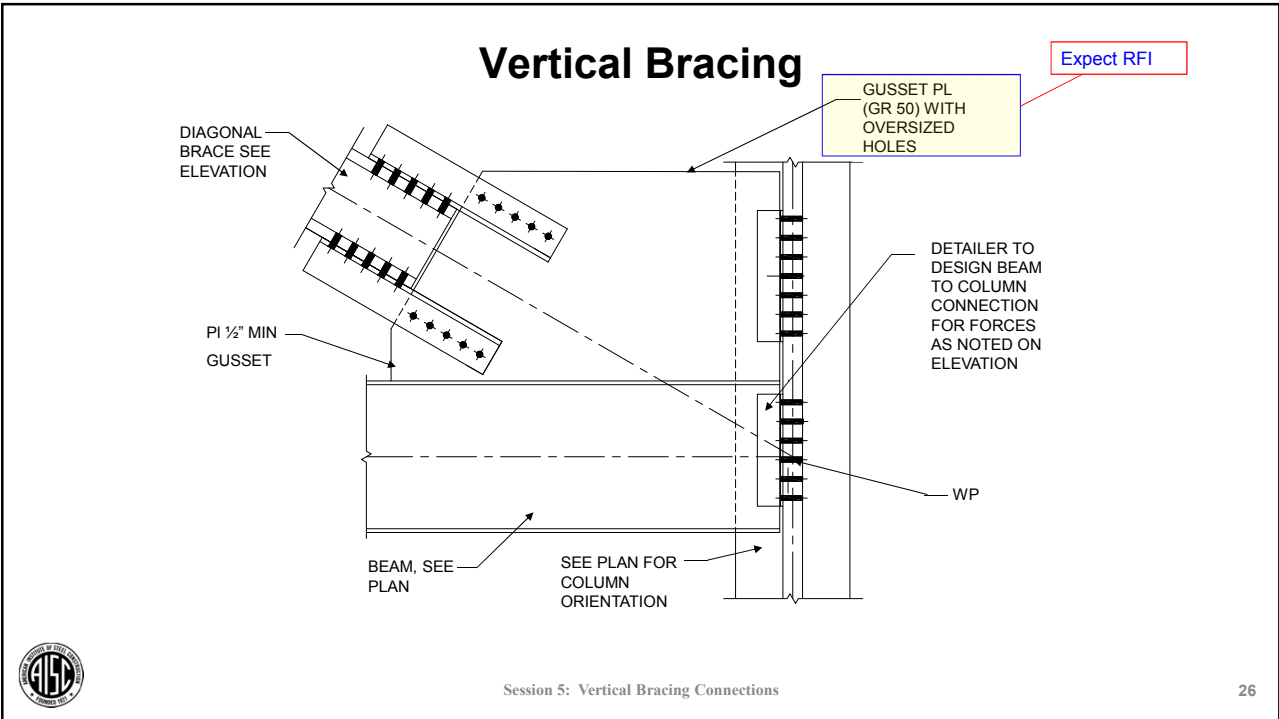
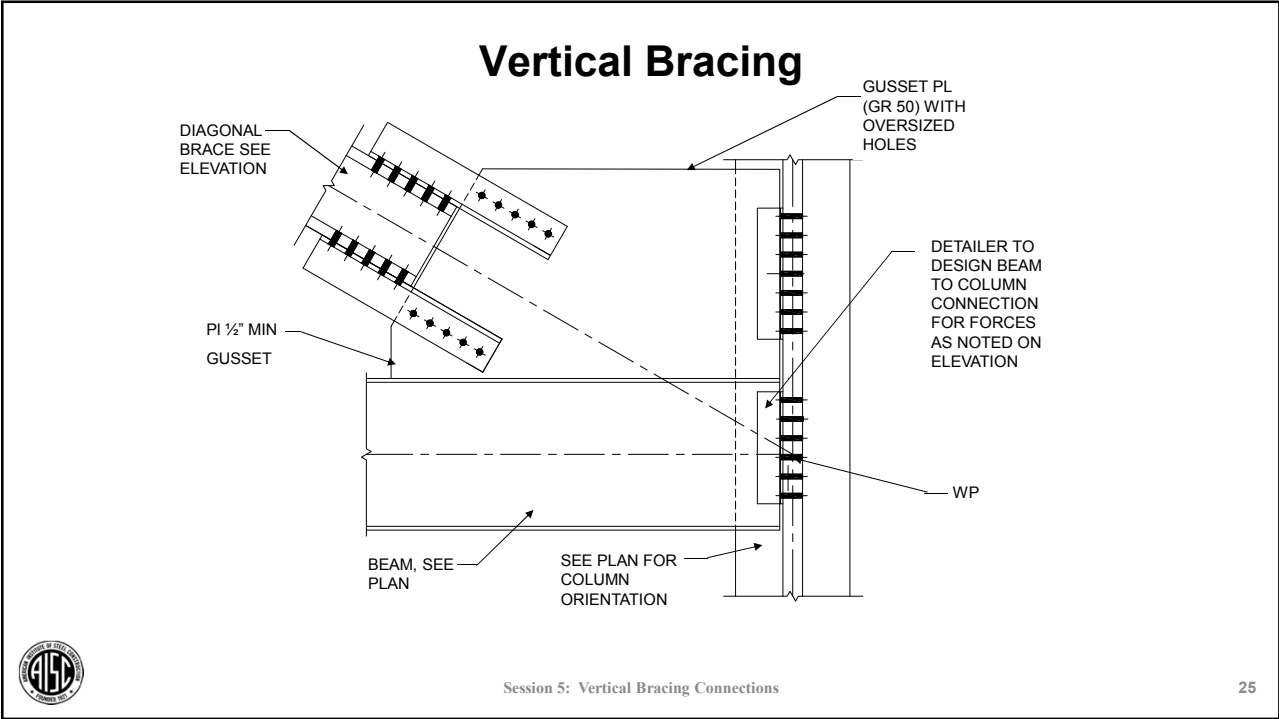

Vertical Bracing

Horizontal short slots in angle at gusset (for overrun of brace depth) and brace, slot length perpendicular to brace.

Bearing bolts in slots perpendicular to the load

Extend angles on one-side for erection aid

Gage in same size angle legs to match

SECTION B-B

SECTION A-A

Session 5: Vertical Bracing Connections 27

Vertical Bracing – Notes to Avoid

CONNECT BRACE FLANGE AND WEB FOR BRACE FORCE, $P = 100\%$ AXIAL STRENGTH OF BRACE OR 75% TENSION STRENGTH OF BRACE AND 20 KIPS SHEAR

SC BOLT, TYP

GUSSET-TO-COLUMN CONNECTION TO DEVELOP "Pv"

BOLTED/WELDED DOUBLE ANGLE CONNECTIONS AT GUSSET

BEAM TO COLUMN CONNECTION PER TABLE ON S200

GUSSET-TO-BEAM CONNECTION TO DEVELOP "Ph"

Session 5: Vertical Bracing Connections 28



Vertical Bracing – Notes to Avoid

CONNECT BRACE FLANGE AND WEB FOR BRACE FORCE, $P = 100\%$ AXIAL STRENGTH OF BRACE OR 75% TENSION STRENGTH OF BRACE AND 20 KIPS SHEAR

SC BOLT, TYP

GUSSET-TO-BEAM CONNECTION TO DEVELOP "Ph"

GUSSET-TO-COLUMN CONNECTION TO DEVELOP "Pv"

BOLTED/WELDED DOUBLE ANGLE CONNECTIONS AT GUSSET

BEAM TO COLUMN CONNECTION PER TABLE ON S200

Session 5: Vertical Bracing Connections

29

Vertical Bracing – Notes to Avoid

CONNECT BRACE FLANGE AND WEB FOR BRACE FORCE, $P = 100\%$ AXIAL STRENGTH OF BRACE OR 75% TENSION STRENGTH OF BRACE AND 20 KIPS SHEAR

SC BOLT, TYP

GUSSET-TO-BEAM CONNECTION TO DEVELOP "Ph"

GUSSET-TO-COLUMN CONNECTION TO DEVELOP "Pv"

BOLTED/WELDED DOUBLE ANGLE CONNECTIONS AT GUSSET

BEAM TO COLUMN CONNECTION PER TABLE ON S200

Session 5: Vertical Bracing Connections

30



Vertical Bracing – Notes to Avoid

CONNECT BRACE FLANGE AND WEB FOR BRACE FORCE, $P = 100\%$ AXIAL STRENGTH OF BRACE OR 75% TENSION STRENGTH OF BRACE AND 20 KIPS SHEAR

SC BOLT, TYP

GUSSET-TO-BEAM CONNECTION TO DEVELOP "Ph"

GUSSET-TO-COLUMN CONNECTION TO DEVELOP "Pv"

BOLTED/WELDED DOUBLE ANGLE CONNECTIONS AT GUSSET

BEAM TO COLUMN CONNECTION PER TABLE ON S200

Session 5: Vertical Bracing Connections

31

Vertical Bracing – Notes to Avoid

CONNECT BRACE FLANGE AND WEB FOR BRACE FORCE, $P = 100\%$ AXIAL STRENGTH OF BRACE OR 75% TENSION STRENGTH OF BRACE AND 20 KIPS SHEAR

SC BOLT, TYP

GUSSET-TO-BEAM CONNECTION TO DEVELOP "Ph"

GUSSET-TO-COLUMN CONNECTION TO DEVELOP "Pv"

BOLTED/WELDED DOUBLE ANGLE CONNECTIONS AT GUSSET

BEAM TO COLUMN CONNECTION PER TABLE ON S200

Session 5: Vertical Bracing Connections

32



Vertical Bracing – Model Transfer

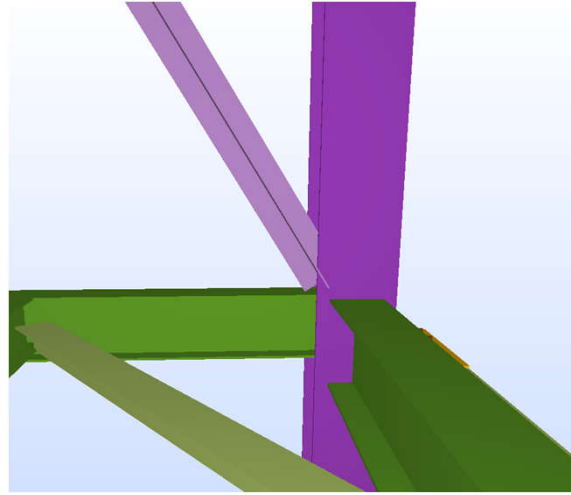

Session 5: Vertical Bracing Connections

33

Vertical Bracing – Model Transfer

	A	B	C	D	E	F	G	H	I	J
	memid	section	risa_member_type	section_id	start_max_axial_transfer	start_min_axial_transfer	start_max_shear_transfer	start_min_shear_transfer	Start_Max_axial	Start_min_axial
2	Column	Column2	Column	Column	Column	Column	Column	Column	Column	Column
84	ROS_172	LL5x5x8x3	VBrace	LL5x5x8x3					191.201841	-0.44519998
85	ROS_173	LL5x5x8x3	VBrace	LL5x5x8x3					229.61399	-0.29399999
86	ROS_174	LL5x5x8x3	VBrace	LL5x5x8x3					239.931289	-0.31814999
98	ROS_190	LL5x5x8x3	VBrace	LL5x5x8x3					257.088288	-0.49874998
99	ROS_191	LL5x5x8x3	VBrace	LL5x5x8x3					232.496239	0
00	ROS_192	LL5x5x8x3	VBrace	LL5x5x8x3					266.979288	0
01	ROS_193	LL5x5x8x3	VBrace	LL5x5x8x3					241.310989	-0.40844998
02	ROS_194	LL5x5x8x3	VBrace	LL5x5x8x3					254.741538	-0.43784998
03	ROS_195	LL5x5x8x3	VBrace	LL5x5x8x3					240.674689	-0.38219998
04	ROS_196	LL5x5x8x3	VBrace	LL5x5x8x3					253.032139	-0.50504998
05	ROS_197	LL5x5x8x3	VBrace	LL5x5x8x3					265.292988	0
06	ROS_198	LL5x5x8x3	VBrace	LL5x5x8x3					229.29584	-0.46829998
07	ROS_199	LL5x5x8x3	VBrace	LL5x5x8x3					242.536339	-14.9005493
10	ROS_200	LL5x5x8x3	VBrace	LL5x5x8x3					255.835638	-14.8028993
14	ROS_205	LL5x5x8x3	VBrace	LL5x5x8x3					343.513784	-21.442049
15	ROS_206	LL5x5x8x3	VBrace	LL5x5x8x3					332.024685	-24.9647989
16	ROS_207	LL5x5x8x3	VBrace	LL5x5x8x3					341.390684	-0.23204999
17	ROS_208	LL5x5x8x3	VBrace	LL5x5x8x3					328.254135	0
18	ROS_209	LL5x5x8x3	VBrace	LL5x5x8x3					348.604184	-0.30764999
20	ROS_210	LL5x5x8x3	VBrace	LL5x5x8x3					331.561635	-0.30764999
21	ROS_211	LL5x5x8x3	VBrace	LL5x5x8x3					354.462134	-0.32234999
22	ROS_212	LL5x5x8x3	VBrace	LL5x5x8x3					337.168635	-0.21209999



Session 5: Vertical Bracing Connections

34



Vertical Bracing – Load Case Break Down

1	Member	Joint	Load	P	V2	V3	T	M2	M3
2	ID	ID	Combo	Kip	Kip	Kip	Kip-ft	Kip-ft	Kip-ft
6808	3365	31	COMB46	-232	0	0	0	0	0
6809	3365	31	COMB47	21	0	0	0	0	0
6810	3365	31	COMB48	-19	0	0	0	0	0
6811	3365	31	COMB49	-237	0	0	0	0	0
6812	3365	31	COMB50	-249	0	0	0	0	0
6813	3365	31	COMB51	11	0	0	0	0	0
6814	3365	31	COMB52	-37	0	0	0	0	0
6815	3366	31	COMB01	-143	0	0	0	0	0
6816	3366	31	COMB02	-229	0	0	0	0	0
6817	3366	31	COMB03	-230	0	0	0	0	0
6818	3366	31	COMB04	-228	0	0	0	0	0
6819	3366	31	COMB05	-218	0	0	0	0	0
6820	3366	31	COMB06	-237	0	0	0	0	0
6821	3366	31	COMB07	-74	0	0	0	0	0
6822	3366	31	COMB08	-92	0	0	0	0	0
6823	3366	31	COMB09	-261	0	0	0	0	0
6824	3366	31	COMB10	-265	0	0	0	0	0



Vertical Bracing

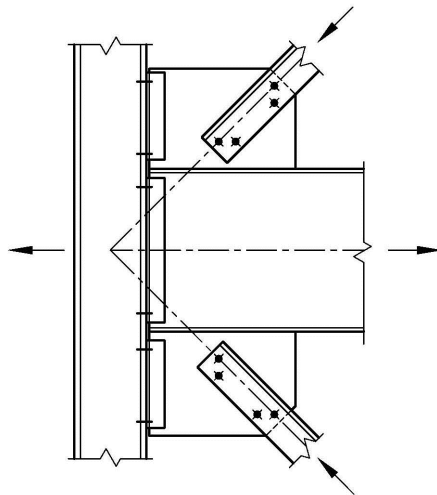

- Indicate if both top and bottom braces in compression

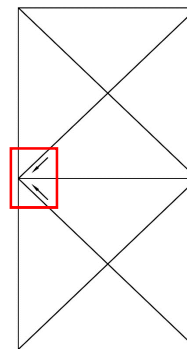

Note: Do not use force from one brace to offset force from opposite brace



Common General Notes

- Notes:
 - ASD or LRFD **Avoid mixing on the same project** ✓
 - Load criteria ✓
 - Bolt pre-tensioning and/or slip critical requirements ✓
 - Shear loads for members in the braced frame ✓
 - Connection work points at member centerlines ✓
 - Transfer force notes ✓
 - Seismic response modification coefficient, R ✓



Session 5: Vertical Bracing Connections

37

Design Notes

- Good Notes
 - Seismic response modification coefficient, R (Table 12.2-1 ASCE 7-16)
 - $R = 3$: Structural steel systems not specifically detailed for seismic resistance. Seismic Design Category A, B or C. Use when possible
 - $R > 3$
 - Ordinary Concentrically Braced Frame (OCBF): $R = 3.25$
 - Special Concentrically Braced Frame (SCBF): Strength of member: $R = 6$
 - Eccentrically Braced Frame (EBF) : $R = 8$
 - Buckling-Restrained Braced Frames (BRBF) : $R = 8$



Session 5: Vertical Bracing Connections

38



GENERAL NOTES

- Notes that could cause RFI
 - All plate and angles are A36
 - Hole type requirements
 - Specific bolt requirements
 - Spacing and edge distance requirements



Most Common RFI Questions

- ASD or LRFD
- Use of Slip Critical bolts
- Alternate Connections
- Full Strength
- HSS Beam Loading
- Transfer forces (TF)
- Column splice loading (Min. Axial)
- Material grade
- Restrictions
- Stitch Plates
- Shear load in beams (especially if a percentage of the Maximum Total Uniform Load, UDL, is used)
- Work Point

REQUEST FOR INFORMATION - DZSE 001



TO:
 ATTN:
 JOB:
 REF:

FROM:
 DATE:
 CC:

NUMBER OF PAGES:

INFORMATION REQUESTED:

IF ALL PAGES ARE NOT RECEIVED, PLEASE CALL JOB CONTACT AS SOON AS POSSIBLE

REQUESTED BY:

ANSWERED BY:
 COMPANY:
 DATE:



Getting Started with Design

- Forces
- Sizes
- System requirements



Getting Started with Design

- Corner Bracing
 - Map transfer force
 - Map gravity loads
 - Map beam sizes
 - Map column sizes

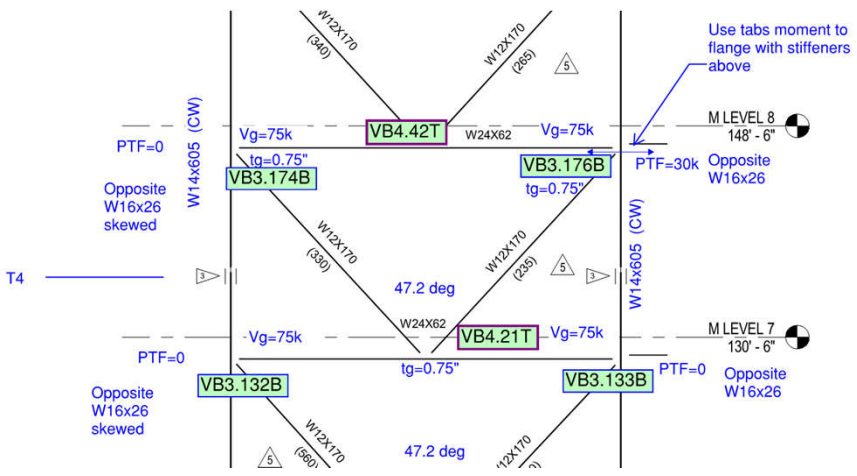

Getting Started with Design

- Corner Bracing
 - Map transfer forces
 - Map gravity loads
 - Map beam sizes
 - Map column sizes

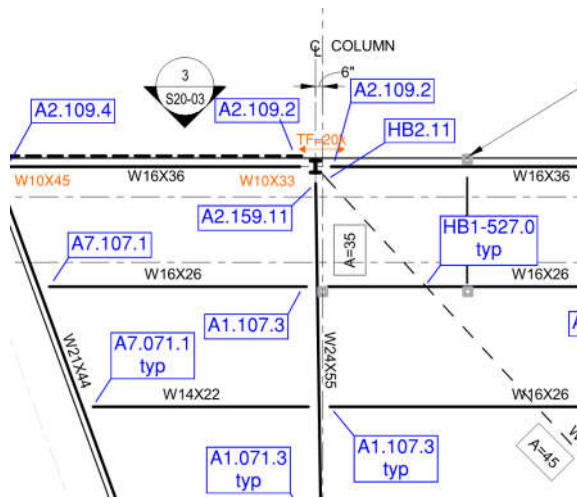

Session 5: Vertical Bracing Connections

43

Getting Started with Design

- Check for stiffeners/doublers in columns

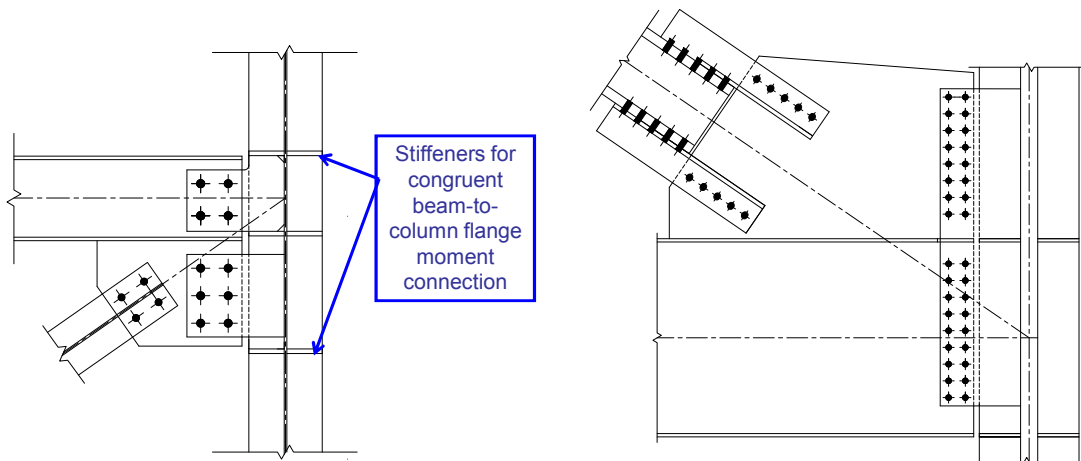

Session 5: Vertical Bracing Connections

44



Getting Started with Design

- Flooring Type

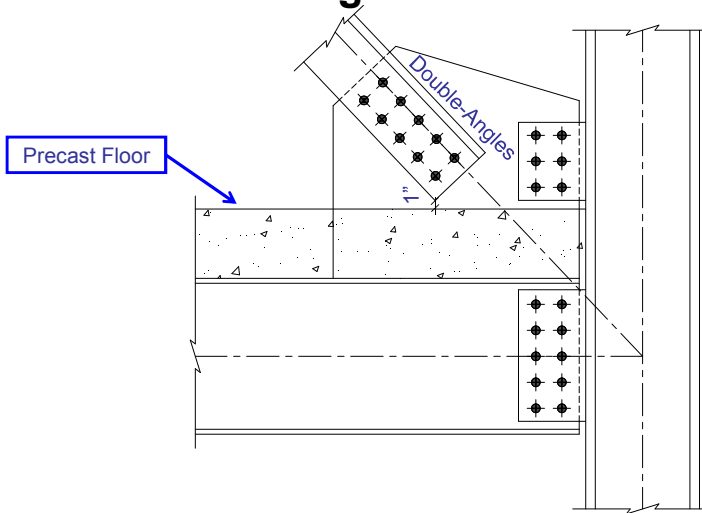

Getting Started with Design

- Double-Angle Requirements
 - Stitch Plates
 - AISC Section E6
 - Table 4-8 to 4-10: Axial Compression Double Angles

$$\left(\frac{L_c}{r}\right)_m = \sqrt{\left(\frac{L_c}{r}\right)_o^2 + \left(\frac{a}{r_i}\right)^2} \quad (E6-1)$$

(1) When $\frac{a}{r_i} \leq 40$

$$\left(\frac{L_c}{r}\right)_m = \left(\frac{L_c}{r}\right)_o \quad (E6-2a)$$

(2) When $\frac{a}{r_i} > 40$

$$\left(\frac{L_c}{r}\right)_m = \sqrt{\left(\frac{L_c}{r}\right)_o^2 + \left(\frac{K_1 a}{r_i}\right)^2} \quad (E6-2b)$$

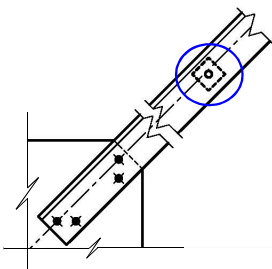
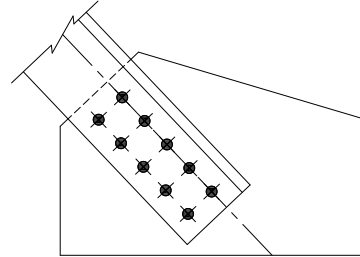

Table 4-9 (continued)
 Available Strength in Axial Compression, kips $F_y = 36$ ksi
 Double Angles—LLBB

Shape	2L6x4x								No. of connectors*
	7/8		3/4		5/8		3/8		
	54.4		47.2		40.0		36.2		
lb/ft	P_n/A_g		$\phi_t P_n$		P_n/A_g		$\phi_t P_n$		b
	ASD	LRFD	ASD	LRFD	ASD	LRFD	ASD	LRFD	
Design									
0	345	518	300	450	252	379	229	343	
4	333	501	290	435	244	366	221	332	
6	319	479	277	417	234	351	212	318	
8	300	451	261	393	220	331	200	300	
10	277	416	242	363	204	307	185	278	
12	252	378	220	331	186	279	169	254	
14	224	337	197	296	166	250	151	228	
16	197	296	173	260	146	220	133	201	
18	170	255	150	225	127	191	116	174	
20	144	216	127	191	108	162	98.6	148	
22	119	179	106	159	90.1	135	82.5	124	
24	100	151	89.0	134	75.7	114	69.3	104	
26	85.5	128	75.9	114	64.5	97.0	59.1	88.8	
28	73.7	111	65.4	98.3	55.6	83.6	50.9	76.6	
30	64.2	96.5	57.0	85.6	48.5	72.9	44.4	66.7	
0	345	518	300	450	252	379	229	343	
4	319	480	273	410	224	336	199	298	
6	304	456	259	390	213	320	189	284	
8	283	425	241	363	198	298	176	265	
10	251	378	214	322	176	264	156	235	
12	222	334	189	284	155	233	136	208	
14	192	289	163	244	133	200	119	179	
16	162	244	137	205	112	168	99.8	150	2



Getting Started with Design



E6. BUILT-UP MEMBERS

1. Compressive Strength

This section applies to built-up members composed of two shapes either (a) interconnected by bolts or welds or (b) with at least one open side interconnected by perforated cover plates or lacing with tie plates. The end connection shall be welded or connected by means of pretensioned bolts with Class A or B faying surfaces.



Session 5: Vertical Bracing Connections

47

Getting Started with Design

- Surface Preparation Requirements
 - Class A Bolts
 - Class B Bolts
 - Galvanizing

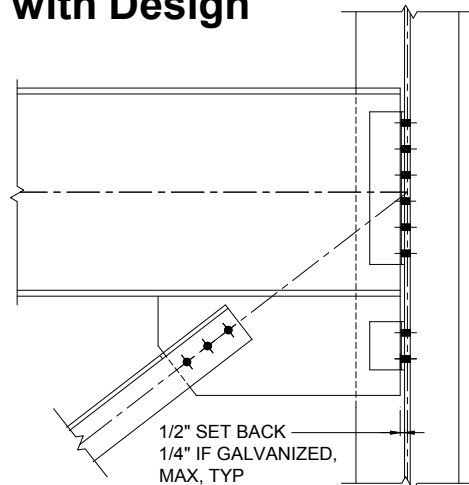

Session 5: Vertical Bracing Connections

48

Getting Started with Design

- Seismic Design, $R > 3$ (AISC 341-16, Section D2.2(d))
 - (d) All bolts shall be installed as pretensioned high-strength bolts. Faying surfaces shall satisfy the requirements for slip-critical connections in accordance with *Specification* Section J3.8 with a faying surface with a Class A slip coefficient or higher.
Exceptions: Connection surfaces are permitted to have coatings with a slip coefficient less than that of a Class A faying surface for the following:
 - (1) End plate moment connections conforming to the requirements of Section E1, or ANSI/AISC 358
 - (2) Bolted joints where the seismic load effects are transferred either by tension in bolts or by compression bearing but not by shear in bolts



Session 5: Vertical Bracing Connections

49

Vertical Bracing

- Work Point requirements

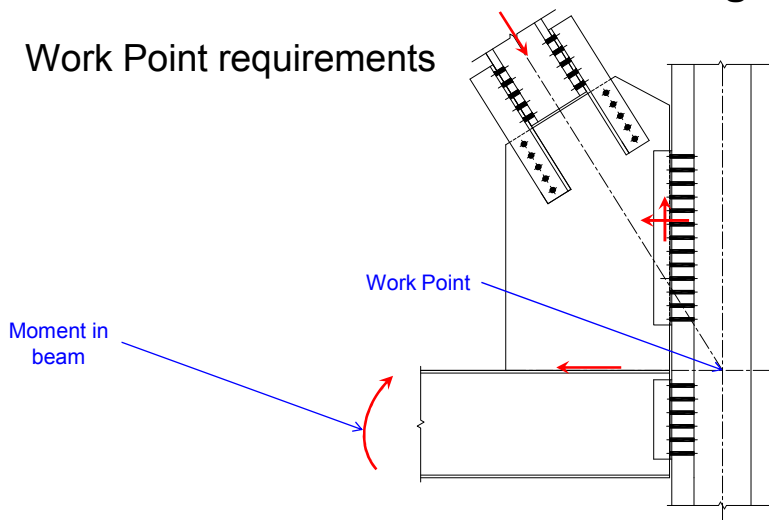

Session 5: Vertical Bracing Connections

50

Getting Started with Design

- Work Point requirements

*See AISC's Design Guide 29

Session 5: Vertical Bracing Connections

51

Getting Started with Design

- WP requirements

$$\eta = \frac{\frac{I_{beam}}{L_{beam}}}{\sum \frac{I_{col}}{L_{col}} + \frac{I_{beam}}{L_{beam}}}$$

$$H' = \frac{(1-\eta)M}{e_b + \bar{\beta}}$$

$$V' = \frac{M - H'\bar{\beta}}{\bar{\alpha}}$$

*Reference AISC's Night School and AISC's DG29

Session 5: Vertical Bracing Connections

52



Getting Started with Design

- WP requirements

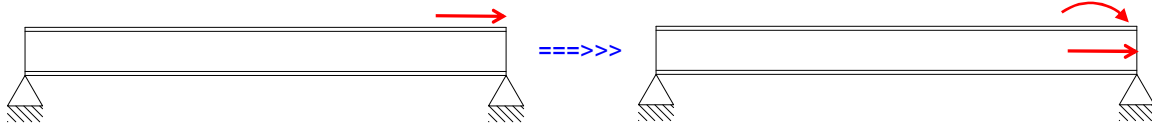

Work Point at Top of Beam

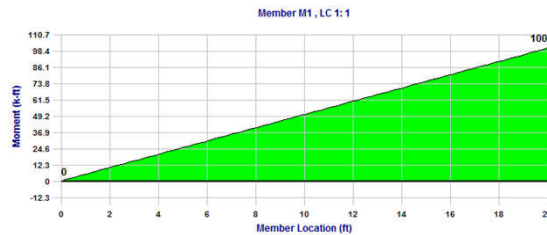

Session 5: Vertical Bracing Connections

53

Frame Analysis

- WP requirements

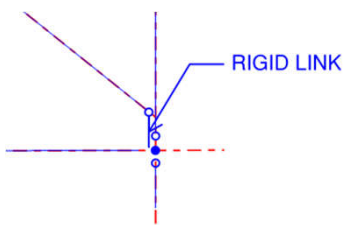

Brace eccentricity
 moment induced in
 beam

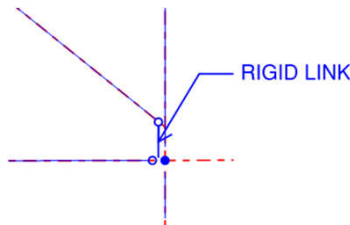

Brace eccentricity
 moment induced in
 column

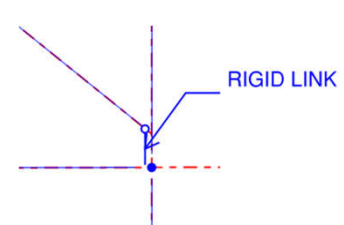

Brace eccentricity
 moment induced in
 column and beam

Note: At least one member framing into joint needs to not be released to the maintain numerical stability of the analysis



Session 5: Vertical Bracing Connections

54

Getting Started with Design

- Work line location
- Bolted on gage, g_1
- Welded on \bar{y}

Table 1-7A
Workable Gages in Angle Legs, in.

g	Leg	12	10	8	7	6	5	4	3 1/2	3	2 1/2	2	1 3/4	1 1/2	1 3/8	1 1/4	1
g_1	6	5	4 1/2	4	3 1/2	3	2 1/2	2	-	-	-	-	-	-	-	-	-
g_2	3	3	3	2 1/2	2 1/4	2	-	-	-	-	-	-	-	-	-	-	-
g_3	2 1/2	2 1/2	3	3	2 1/2	2	-	-	-	-	-	-	-	-	-	-	-
g_4	2 1/2	-	-	-	-	-	-	-	-	-	-	-	-	-	-	-	-

Note: Other gages are permitted to suit specific requirements subject to clearances and edge distance limitations.

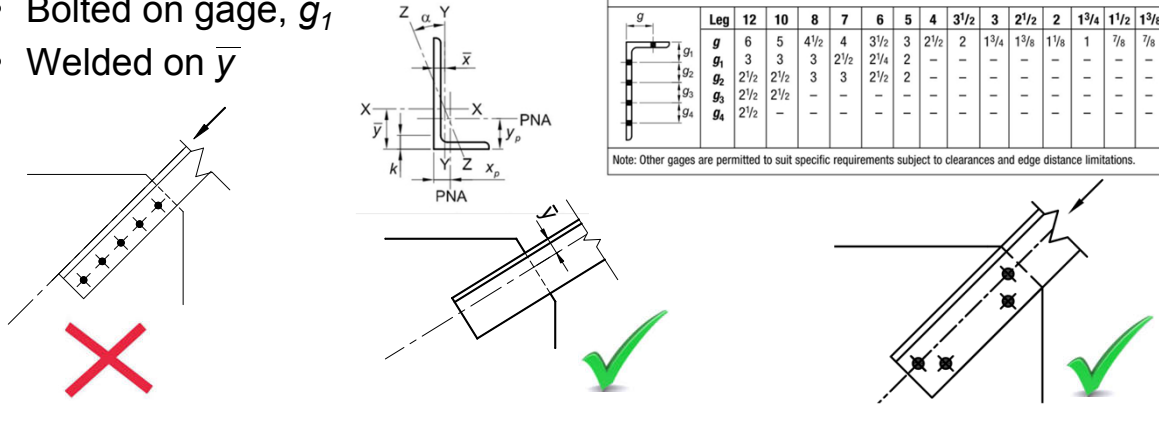

Transfer Forces

- Lateral force in a discontinuous bay needs to be transferred to the lateral system below

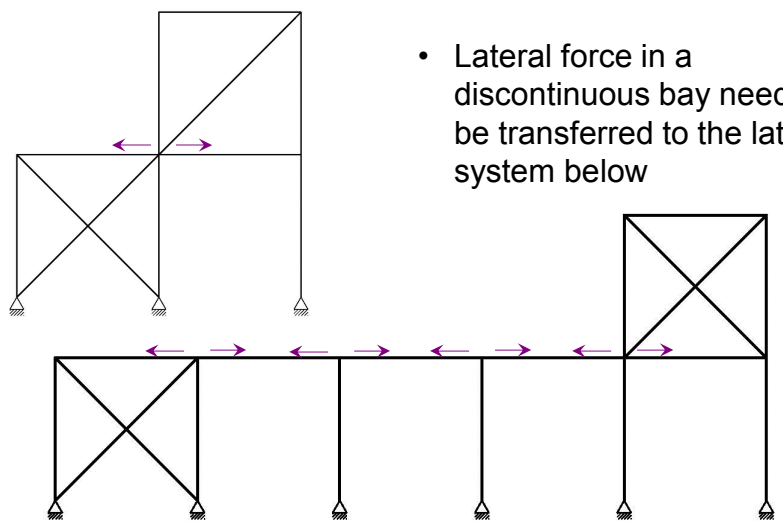

Transfer Forces - Discontinuous Braced Bays

Sum forces in "X" direction
 $TF = -3.34k - 9.6k(0.707)$
 $= -10k (T)$

Sum forces in "X" direction
 $TF = -14.0k(0.707) - 0.115k$
 $= -10.0k (T)$

- To determine transfer force:
 - Determine the transfer plane
 - sum forces either side of that plane

Session 5: Vertical Bracing Connections

57

Transfer Forces - Discontinuous Braced Bays

Sum forces in "X" direction
 $TF = -3.34k - 9.6k(0.707)$
 $= -10k (T)$

Sum forces in "X" direction
 $TF = -14.0k(0.707) - 0.115k$
 $= -10.0k (T)$

- To determine transfer force:
 - Determine the transfer plane
 - sum forces either side of that plane

Session 5: Vertical Bracing Connections

58



Getting the Load to the Lateral System

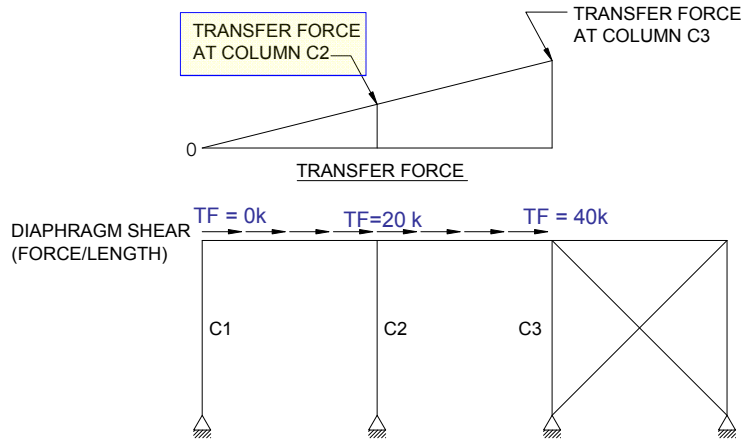

Transfer Forces

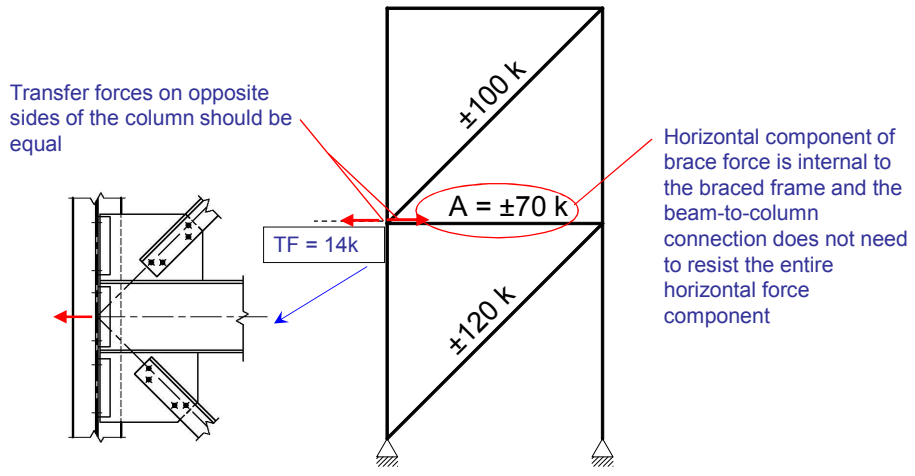

Getting the Load to the Lateral System

The diagram shows a vertical bracing connection between two beams. On the left is a W12x19 beam, and on the right is a W10x12 beam. A W21x73 section is used as a vertical brace, with its top flange connected to the top flange of the W12x19 beam and its bottom flange connected to the top flange of the W10x12 beam. The brace is braced against lateral movement by two diagonal members forming an X-shape. A dashed line indicates the centerline of the W21x73 section.

W12x19 W21x73 W10x12



Session 5: Vertical Bracing Connections

61

Getting the Load to the Lateral System

The diagram is identical to the one on slide 61, but includes three callout boxes with red arrows pointing to specific details:

- No transfer force**: Points to the top flange connection of the W12x19 beam.
- No studs**: Points to the top flange connection of the W12x19 beam.
- Different beam depths**: Points to the top flange connections of both the W12x19 and W10x12 beams.

W12x19 W21x73 W10x12



Session 5: Vertical Bracing Connections

62



Transfer Forces

The diagram illustrates a vertical bracing connection between two beams. A central W21x73 beam is supported by two W21x44 (10) beams. The W21x44 beams are shown with horizontal double-headed arrows and boxes labeled $\pm 30\text{ k}$, indicating the transfer of forces. The W21x73 beam is shown with a dashed line, suggesting it is the primary load-carrying member. The entire assembly is supported by vertical columns.

Session 5: Vertical Bracing Connections

63

Transfer Forces

- Transfer Forces at Roof
 - Metal deck has limited strength

The diagram shows a multi-story building frame with five floors. The roof level is highlighted with a circled 'R'. The frame consists of vertical columns and horizontal beams. The roof level is shown with a circled 'R' and a circled '1'. The diagram illustrates the transfer of forces from the roof level down to the columns.

Session 5: Vertical Bracing Connections

64



Diaphragm Strength

B, BA 18 GA. Diaphragm Design

Design Thickness = 0.0474 in.
Support Fasteners: 5/8" Puddle Welds
Side Lap Fasteners: # 10 Screws

ϕ (EQ): 0.55 Ω (EQ): 3.00
 ϕ (Wind): 0.70 Ω (Wind): 2.35
 ϕ (Other): 0.60 Ω (Other): 2.65

Fill Type	Support Fastener Pattern	Side Lap Conn. per Span	Nominal Diaphragm Shear Strength (plf)																K ₁ (ft. ²)
			Center to Center Span (ft. - in.)																
			5-0	5-6	6-0	6-6	7-0	7-6	8-0	8-6	9-0	9-6	10-0	11-0	12-0	12-6	12-12		
No Fill (Bare Deck)	36/5	D _v = 281 (BA) D _v = 288	11	2858	2663	2490	2335	2196	2072	1950	1855	1766	1683	1606	1471	1356	1220	0.148	
			0	994	999	820	753	696	646	603	564	530	500	472	425	390	379	0.738	
			2	1347	1238	1147	1066	986	917	857	804	756	-	-	-	-	-	-	0.437
			3	1504	1389	1288	1201	1123	1053	984	923	869	821	777	703	644	-	-	0.363
			4	1653	1530	1423	1329	1246	1172	1106	1043	982	928	879	795	729	709	-	0.310
			5	1791	1664	1552	1452	1364	1285	1214	1150	1092	1035	981	888	814	792	-	0.271
			6	1919	1789	1673	1570	1477	1393	1318	1250	1188	1132	1081	980	899	874	-	0.241
			7	2039	1907	1788	1681	1585	1498	1419	1348	1282	1223	1168	1072	983	957	-	0.216
			8	2149	2016	1896	1787	1688	1598	1516	1442	1373	1311	1253	1151	1064	1038	-	0.196
			9	2250	2118	1997	1887	1786	1694	1609	1532	1461	1396	1336	1229	1137	1110	-	0.180
			10	2344	2213	2092	1981	1879	1785	1699	1619	1546	1479	1417	1305	1209	1180	-	0.166
11	2430	2301	2181	2070	1967	1872	1784	1703	1628	1559	1495	1379	1279	1249	-	0.154			
	36/4	D _v = 399 (B) D _v = 408 (BA)	0	753	680	619	568	524	485	452	422	396	373	352	316	289	262	0.923	
			2	1105	1019	945	880	814	757	706	662	622	-	-	-	-	-	-	0.496
			3	1253	1161	1080	1009	946	890	834	782	735	694	657	593	544	-	-	0.403
			4	1389	1292	1207	1131	1063	1002	947	898	848	801	759	686	629	612	-	0.339
			5	1511	1413	1324	1244	1173	1108	1049	996	948	904	860	778	713	694	-	0.293
			6	1622	1523	1432	1350	1276	1206	1146	1090	1039	992	948	871	798	777	-	0.257
			7	1721	1622	1532	1449	1372	1303	1239	1180	1126	1076	1030	949	878	857	-	0.230
			8	1810	1713	1623	1539	1462	1391	1326	1265	1209	1157	1109	1023	949	926	-	0.207
			9	1889	1795	1706	1623	1546	1474	1407	1346	1288	1235	1185	1096	1018	994	-	0.189
			10	1960	1869	1782	1700	1624	1552	1484	1422	1363	1308	1257	1165	1084	1058	-	0.174
			11	2024	1936	1851	1771	1695	1624	1557	1493	1434	1379	1326	1232	1148	1123	-	0.161

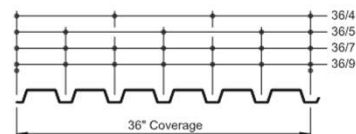

B, BI, BV, BIV, BA, BIA, F, 1.5FDR, 1.5FDI, 1.5FDV, 1.5FDIV, 1.5CD, 1.5CDI

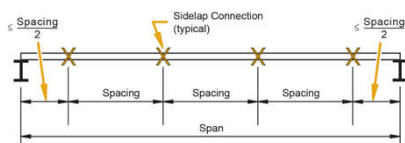

1511 plf/Ω(Wind)
1511/2.35 = 643 plf

NEW MILLENNIUM BUILDING SYSTEMS



Diaphragm Strength

- Transfer Forces at Composite Deck
 - Consider topping slab

$$\phi V_n = \phi L_s t_s (2\lambda \sqrt{f'_c}) \quad \text{ACI 12.5.3.3}$$

$$\phi = 0.75$$

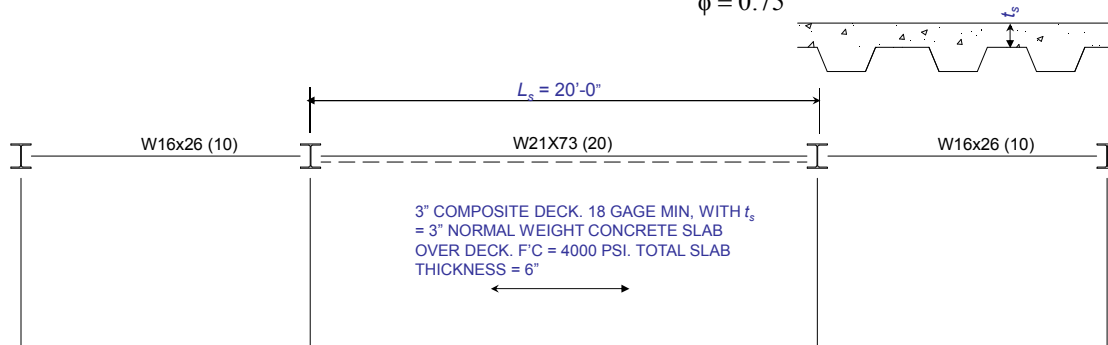

Diaphragm Strength

- Transfer Forces at Composite Deck

$$\phi V_n = \phi L_s t_s (2\lambda \sqrt{f'_c}) \quad \text{ACI 12.5.3.3}$$

$$\phi = 0.75$$

$$\Sigma TF = \max(\text{abs}(\Sigma F_{x2} - \Sigma F_{x1}) - \phi V_n, 0 \text{ kips})$$

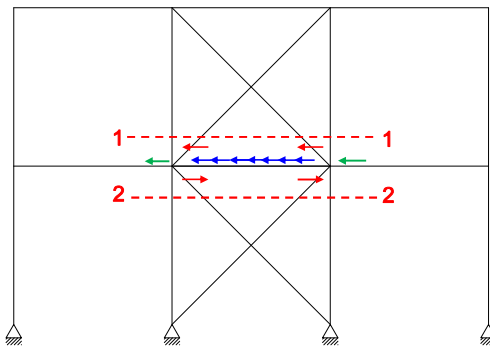

Red Arrow = F_x = Brace horizontal component
 Blue Arrow = Diaphragm strength
 Green Arrow = Transfer Forces



Diaphragm Strength

- Use Table 3-21 for Stud Strength

Table 3-21
 $F_u = 65 \text{ ksi}$ **Shear Stud Anchor**
 Nominal Horizontal Shear Strength
 for One Steel Headed Stud Anchor, Q_n , kips

Deck
 Perpendicular
 Weak Studs
 per rib
 ($R_p = 0.60$)

Deck Condition	Stud Anchor Diameter, in.	Normal Weight Concrete		Lightweight Concrete	
		$w_c = 145 \text{ pcf}$		$w_c = 110 \text{ pcf}$	
		$f'_c = 3 \text{ ksi}$	$f'_c = 4 \text{ ksi}$	$f'_c = 3 \text{ ksi}$	$f'_c = 4 \text{ ksi}$
1	3/8	4.31	4.31	4.28	4.31
	1/2	7.66	7.66	7.60	7.66
	5/8	12.0	12.0	11.9	12.0
	3/4	17.2	17.2	17.1	17.2
2	3/8	3.66	3.66	3.66	3.66
	1/2	6.51	6.51	6.51	6.51
	5/8	10.2	10.2	10.2	10.2
	3/4	14.6	14.6	14.6	14.6



Diaphragm Strength

- Stud Strength (*Specification Eq. I8-1*)

$$Q_n = 0.5 A_{sa} \sqrt{f'_c E_c} \leq R_g R_p A_{sa} F_u$$

A_{sa} = area of stud, in²

E_c = concrete modulus of elasticity = $w_c^{1.5} \sqrt{f'_c}$, ksi

F_u = specified minimum tensile strength of stud = 65 ksi

$$Q_n = 0.5 (0.4418 \text{ in}^2) \sqrt{(4 \text{ ksi})} \left[(145 \text{ pcf})^{1.5} (\sqrt{4 \text{ ksi}}) \right]$$

$$= 26.1 \text{ kips/stud}$$

$$R_g R_p A_{sa} F_u = 1.0 (0.6) (0.4418 \text{ in}^2) (65 \text{ ksi})$$

$$= 17.2 \text{ kips/stud, controls}$$

User Note: The table below presents values for R_g and R_p for several cases. Available strengths for steel headed stud anchors can be found in the AISC *Steel Construction Manual*.

Condition	R_g	R_p
No decking	1.0	0.75
Decking oriented parallel to the steel shape $\frac{w_r}{h_r} \geq 1.5$ $\frac{w_r}{h_r} < 1.5$	1.0	0.75
	0.85 ^(a)	0.75
Decking oriented perpendicular to the steel shape Number of steel headed stud anchors occupying the same decking rib:		
	1	0.6 ^(b)
	2	0.85
3 or more	0.7	0.6 ^(b)

h_r = nominal rib height, in. (mm)
 w_r = average width of concrete rib or haunch (as defined in Section I3.2c), in. (mm)
^(a) For a single steel headed stud anchor
^(b) This value may be increased to 0.75 when $e_{stud} \geq 2$ in. (50 mm).



Fabricator Preferences and Standards

- Plate Grade: A36 or Grade 50 plate.
 - Cost increase for Grade 50 plate
 - Recommended if single plate connections
- Angle Grade: A36 or Grade 50
 - Typically no cost differences
- Bolt preference
- Connection preferences

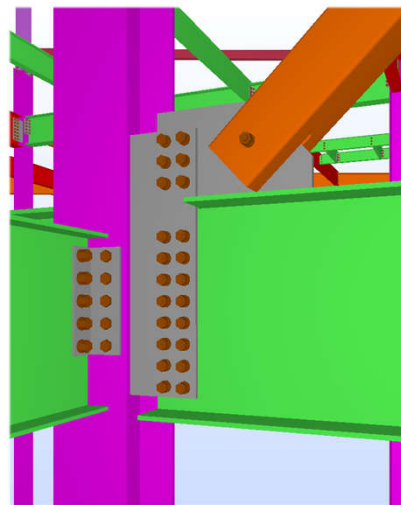

Fabricator Preferences

- Connection Preferences
 - Single Plate, Double-Angles, End Plates
 - Matching gusset thickness
 - Shipping limitations
- Detailing standards
 - Preferred angle sizes
 - HSS slot widths
 - Lap start/stops

Gusset thickness at opposite ends to match, increase as required, typ.

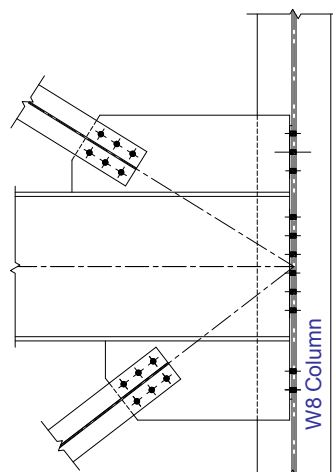
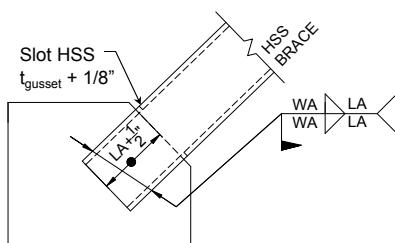

Vertical Bracing – References

- AISC’s Design Guide 29 (DG29)
- Handbook of Structural Steel Connection Design and Details
- AISC’s Night School 6
- Steel Tips
- 15th Ed. Manual, Part 13
- AISC’s Design Examples

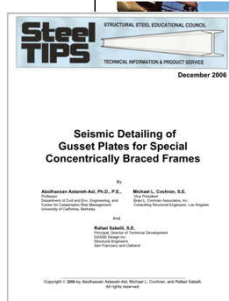
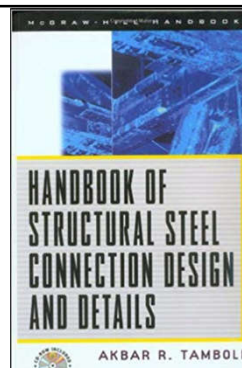
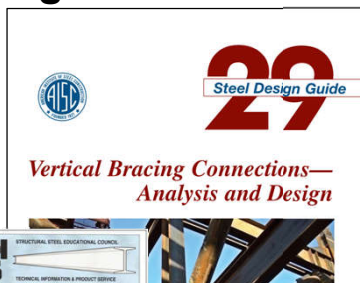

Vertical Bracing – Articles

- *Effective Length Factors for Gussets Plate Buckling*, EJ 2nd Qtr, 2006, Bo Dowswell
- *Effective Length Factors for Gussets Plates in Chevron Braced Frames*, EJ 3rd Qtr, 2012, Bo Dowswell
- *The Effect of Eccentricity on Brace-to-gusset Angles*, EJ 4th Qtr, 1996, W.A. Thornton

Gusset Configuration	Effective Length Factor	Buckling Length	$\frac{P_{exp}}{P_{calc}}$
Compact corner	— ^b	— ^b	1.36
Noncompact corner	1.0	l_{avg}	3.08
Extended corner	0.6	l_1	1.45
Single brace	0.7	l_1	1.45
Chevron	0.65	l_1	1.17

^a Table 7 from Dowswell (2006) with revisions.
^b Yielding is the applicable limit state for compact corner gusset plates; therefore, the effective length factor and the buckling length are not applicable.

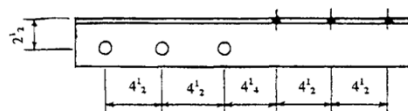

Vertical Bracing – Articles

- *The Whitmore Section*, MS, July 2011, WA Thornton and Carlo Lini
- *Recommendations for Shear Lag Factors for Longitudinally Welded Tension Members*, EJ 1st Qtr, 2012, Patrick Fortney and WA Thornton

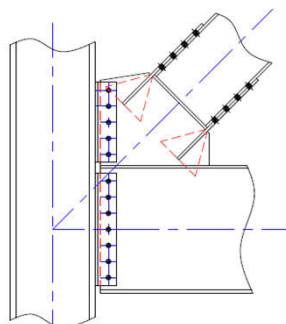

(a) Correct Whitmore length.

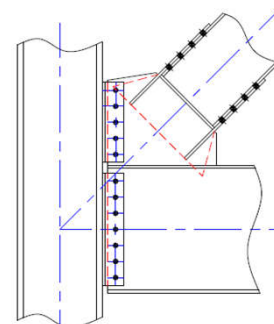

(b) Incorrect Whitmore length.

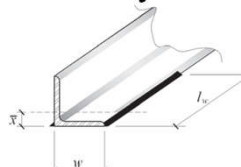

Vertical Bracing – Articles

- *Prying Action - a General Treatment*, EJ 2nd Qtr, 1985, WA Thornton
- *Designing Compact Gussets with the Uniform Force Method*, EJ 1st Qtr, 2008, Larry Muir
- *24 Tips for Simplifying Braced Frame Connections*, MS May 2006, Victor Shneur



Session 5: Vertical Bracing Connections

75

Connections-Bracing

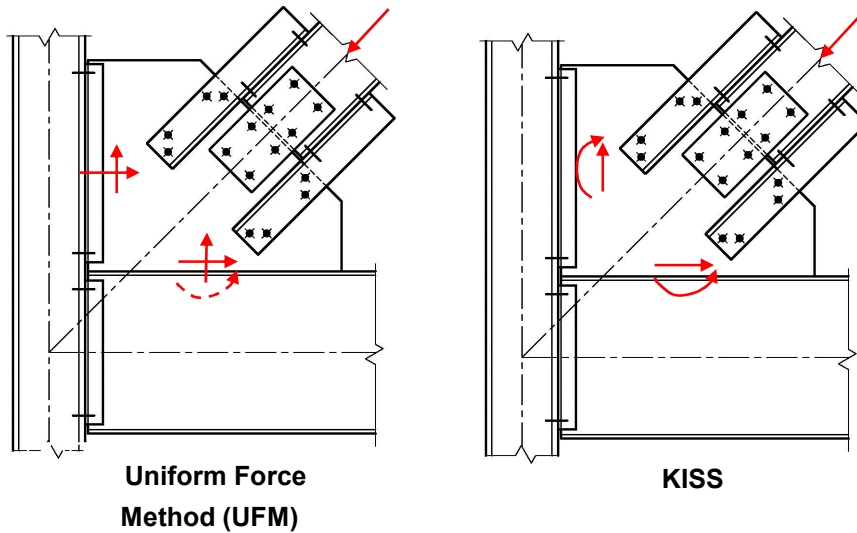

Session 5: Vertical Bracing Connections

76

Connections-Bracing UFM

$$V_b = \frac{e_b}{r} P$$

$$H_b = \frac{\alpha}{r} P$$

$$V_c = \frac{\beta}{r} P$$

$$H_c = \frac{e_c}{r} P$$

UFM

Session 5: Vertical Bracing Connections

77

Connections-Bracing UFM

*Reference AISC's Night School 6 and AISC's DG29

● = Point of zero moment

$$y = mx + b$$

$$y_{col_line} = \frac{\beta}{e_c} x + e_b$$

$$y_{work_line} = \frac{1}{\tan(\theta)} x$$

$$y_{beam_line} = \frac{e_b}{\alpha} x - \frac{e_b e_c}{\alpha}$$

UFM

Session 5: Vertical Bracing Connections

78



Connections-Bracing UFM

*Reference AISC's Night School 6 and AISC's DG29

Work line = column line and solve for x

$$\frac{1}{\tan(\theta)} x = \frac{\beta}{e_c} x + e_b \quad x = \frac{e_b}{\left(\frac{1}{\tan(\theta)} - \frac{\beta}{e_c} \right)}$$

Work line = beam line and solve for x

$$\frac{1}{\tan(\theta)} x = \frac{e_b}{\alpha} x - \frac{e_b e_c}{\alpha}$$

$$x = \frac{-e_b e_c}{\alpha \left(\frac{1}{\tan(\theta)} - \frac{e_b}{\alpha} \right)}$$

Session 5: Vertical Bracing Connections 79

Connections-Bracing UFM

*Reference AISC's Night School 6 and AISC's DG29

Set x = x

$$\frac{-e_b e_c}{\alpha \left(\frac{1}{\tan(\theta)} - \frac{e_b}{\alpha} \right)} = \frac{e_b}{\left(\frac{1}{\tan(\theta)} - \frac{\beta}{e_c} \right)}$$

Simplify

$$\alpha - \beta \tan(\theta) = e_b \tan(\theta) - e_c \quad (\text{eq. 13-1})$$

Session 5: Vertical Bracing Connections 80



Connections-Bracing UFM

*Reference AISC's Night School and AISC's DG29

$$\alpha - \beta \tan(\theta) = e_b \tan(\theta) - e_c \quad (\text{eq. 13-1})$$

$$r = \sqrt{(\alpha + e_c)^2 + (\beta + e_b)^2} \quad (\text{eq. 13-6})$$

$$V_b = \frac{e_b}{r} P \quad H_b = \frac{\alpha}{r} P$$

$$V_c = \frac{\beta}{r} P \quad H_c = \frac{e_c}{r} P$$

Session 5: Vertical Bracing Connections 81

Connections-Bracing UFM

*Reference AISC's Night School 6 and AISC's DG29

$$\alpha - \beta \tan(\theta) = e_b \tan(\theta) - e_c \quad (\text{eq. 13-1})$$

Can set $\bar{\beta} = \beta$ and solve for α .
 If $\bar{\alpha} = \alpha$, no moment

Can set $\bar{\alpha} = \alpha$ and solve for β .
 If $\bar{\beta} = \beta$, no moment

To column flange, set $\bar{\beta} = \beta$

To column web, set $\bar{\alpha} = \alpha$

Session 5: Vertical Bracing Connections 82



Connections-Bracing UFM

*Reference AISC's Night School 6 and AISC's DG29

$$\alpha - \beta \tan(\theta) = e_b \tan(\theta) - e_c \quad (\text{eq. 13-1})$$

$$V_b = \frac{e_b}{r} P \qquad V_c = \frac{\beta}{r} P$$

$$H_b = \frac{\alpha}{r} P \qquad H_c = \frac{e_c}{r} P$$

$$M_b = V_b(\alpha - \bar{\alpha}) \qquad M_c = H_c(\beta - \bar{\beta})$$

Note: If to column web, $e_c = 0$ in.

UFM

Session 5: Vertical Bracing Connections

83

Connections-Bracing UFM

*Reference AISC's Night School 6 and AISC's DG29

$$V_b = \frac{e_b}{r} P - \Delta V_b$$

$$H_b = \frac{\alpha}{r} P$$

$$M_b = \frac{e_b}{r} P(\alpha - \bar{\alpha}) + \Delta V_b \bar{\alpha}$$

$$V_c = \frac{\beta}{r} P + \Delta V_b \qquad H_c = \frac{e_c}{r} P$$

UFM

Session 5: Vertical Bracing Connections

84

UFM Special Case – Compact Gussets

$$\text{ATAN}\left(\frac{e_c}{\beta}\right) > \theta$$

$$\text{ATAN}\left(\frac{\alpha'}{e_b}\right) < \theta$$

Control point

Session 5: Vertical Bracing Connections

85

UFM Special Case – Parallel Force Method (PFM)

$$\text{ATAN}\left(\frac{e_c}{\beta}\right) = \theta$$

$$\text{ATAN}\left(\frac{\alpha'}{e_b}\right) = \theta$$

*Reference AISC's
 AISC's DG29

Session 5: Vertical Bracing Connections

86



Connections-Bracing KISS

$$H_b = P \cos(\theta)$$

$$M_b = H_b(e_b)$$

$$V_c = P \sin(\theta)$$

$$M_c = V_c(e_c)$$

KISS

Session 5: Vertical Bracing Connections

87

Connections-Bracing UFM

- H_c from gusset-to-column to column-to-beam
- H_b force is not resisted by column-to-beam connection
- V_b from gusset-to-beam to beam-to-column
- Add gravity to V_b
- Consider transfer forces and H_c
- Allows for force redistribution

UFM

Session 5: Vertical Bracing Connections

88

Connections-Bracing KISS

- No H_c
- No V_b
- Does not impact beam-to-column connection
- **Need to consider moment at beam and at column**

UFM
Session 5: Vertical Bracing Connections
89

Connections-Bracing

UFM Advantage

Possible KISS Advantage

Session 5: Vertical Bracing Connections
90

Connections-UFM

UFM Special Case IV

$$F = \frac{R(e_c)}{\beta + e_b}$$

$$M_F = F\beta$$

Session 5: Vertical Bracing Connections 91

Connections-UFM Gravity Distribution

UFM Special Case IV

$$F = \frac{R(e_c)}{\beta + e_b}$$

$$M_F = F\beta$$

Session 5: Vertical Bracing Connections 92



Connections-UFM

UFM Special Case IV

- No eccentricity at bolt group if $e_c = e$

$$H_c = H_c + F$$

$$M_b = M_b + M_F$$

$$M_F + F(e_b) = R(e)$$

$$H_b = H_b + F$$

Session 5: Vertical Bracing Connections 93

Details for High Axial Load

Session 5: Vertical Bracing Connections 94

Details for High Axial Load and/or Moment

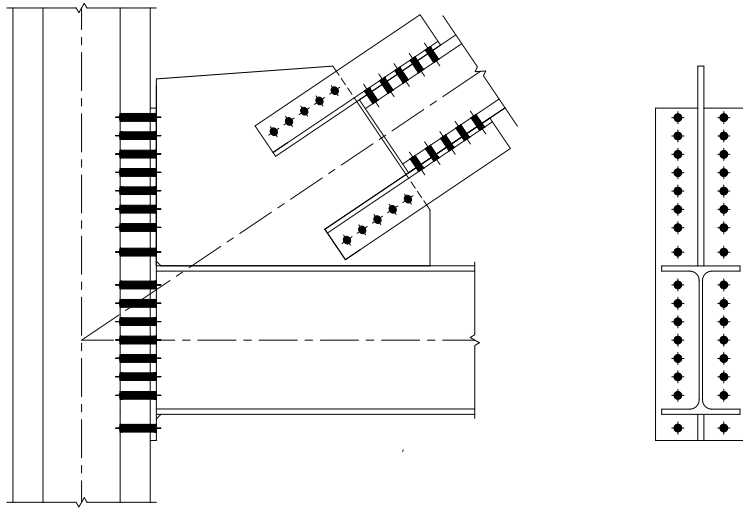

Chevron Connections

- Stability bracing
- Brace force directions

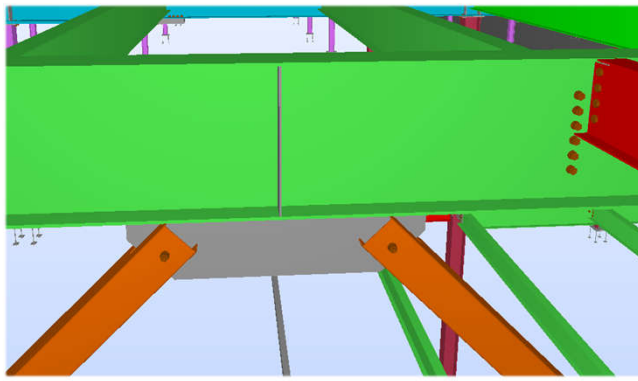

Chevron Connections

- Stability bracing
 - Beam framing into WP ✓
 - Tension brace
 - Stiffeners and studs on top

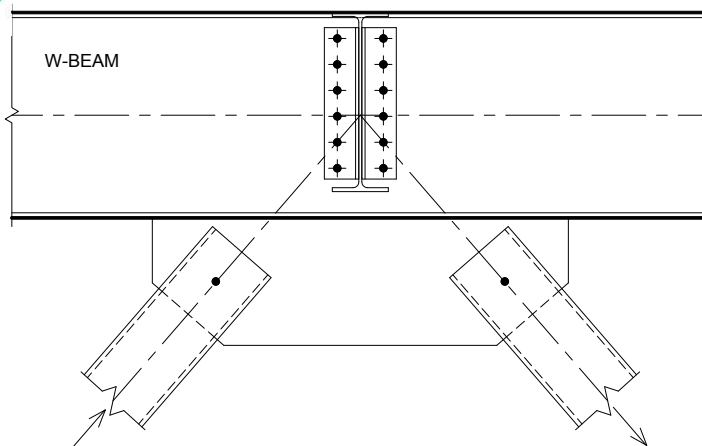

Session 5: Vertical Bracing Connections

97

Chevron Connections

- Stability bracing
 - Beam framing into WP ✓
 - Tension brace
 - Stiffeners and studs

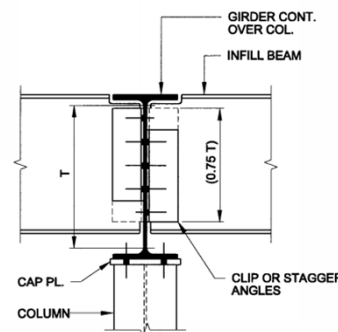

Reference AISC's 15 Ed. Manual, pp 2-16 and 2-17:

1. When an infill beam frames into the continuous beam at the column top, the required stability normally can be provided by using connection element(s) for the infill beam that cover three-quarters or more of the T-dimension of the continuous beam. Alternatively, connection elements that cover less than three-quarters of the T-dimension of the continuous beam can be used in conjunction with partial-depth stiffeners in the beam web along with a moment connection between the column top and beam bottom to maintain alignment of the beam/column assembly. A cap plate of reasonable proportions and four bolts will normally suffice.

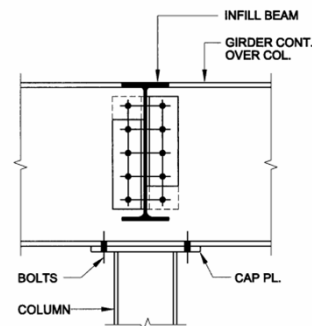

Session 5: Vertical Bracing Connections

98



Chevron Connections

- Optimize connections

$PL \frac{3}{8}$ STIFFENER
 WITH $\frac{1}{4}$ " FILLET WELD
 PER DETAIL 5/S40-04,
 N2, N3

W-BEAM
 T/STEEL
 EL: SEE PLAN
 GUSSET PLATE
 HSS DIAGONAL BRACE, TYPICAL. SEE BRACING ELEVATION FOR SIZES AND BRACE FORCES ("P1" AND "P2") (TENSION OR COMPRESSION) SLOT HSS AT GUSSET PLATE
 W.P.
 W.P.
 HSS BRACES
 VB4-1 TYPICAL BRACE AT BEAM CENTER - CHEVRON

NOTE:
 N1. WELDERS IN FIELD WILL ADD WELD FOR GAP PER AWS. DO NOT ADD WELD FOR GAP IN DETAILING
 N2. STIFFENER ONLY NEEDED WHERE PERPENDICULAR BEAM THAT HAS A CONNECTION DEPTH = $\frac{3}{4}$ CHEVRON BEAM DEPTH DOES NOT FRAME INTO CHEVRON BEAM AT WP. SEE RFI 20 RESPONSE
 N3. AT LOCATIONS THAT REQUIRE DOUBLERS, DOUBLER TO BE CONTINUOUS. WELD STIFFENER TO DOUBLER AS NEEDED.

Session 5: Vertical Bracing Connections

99

Chevron Connections

- Check for doublers

$P_1 \neq P_2$

$\frac{V_1 + V_2}{2} \pm \frac{2M}{L}$
 $\frac{V_1 + V_2}{2}$
 P_2
 P_1
 $\frac{V_1 + V_2}{2}$
 $V_a = \frac{2M}{L}$

Session 5: Vertical Bracing Connections

100

Single Brace Connections

- Stability Concern
 - See Chapter C and Appendix 6 for Stability
 - Web compression buckling: *Spec* Equation J10-8 developed from point loads and restrained flanges

See *Spec* Appendix Section 6.2.2 for point bracing (nodal bracing) required strength and stiffness

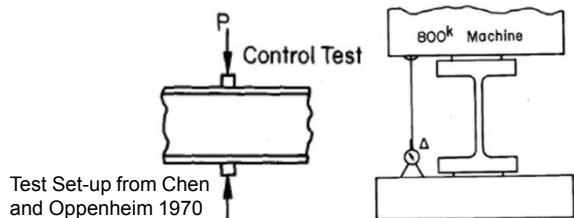

Test Set-up from Chen and Oppenheim 1970

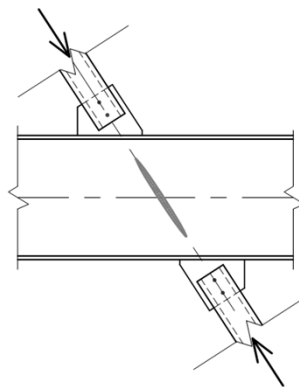

Brace to Base

- Work Point location: Typically top of plate or bottom of Plate
- See DG29
- Indicate base plate can or can not be extended
- Avoid welding washer plates unless anchor rods checked for shear and bending

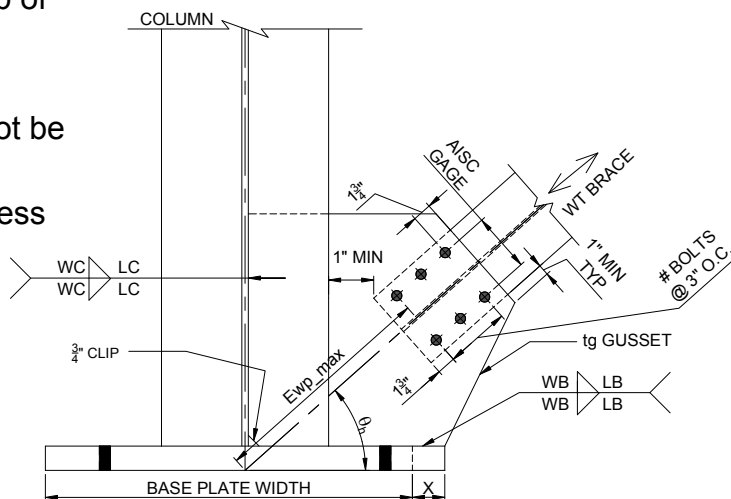

Brace to Base

- Work Point location – Top of Plate

$$H = P \sin \theta$$

$$V = P \cos \theta$$

$$V_c = V$$

$$H_b = H$$

Session 5: Vertical Bracing Connections 103

Brace to Base

- Work Point location – Bottom of Plate

Note: "e" is a negative if below the top of base plate

$$H = P \sin \theta$$

$$V = P \cos \theta$$

$$V_c = V$$

Sum Moments about $\bar{\beta}$ to determine H_b

$$H_b = \frac{H(\bar{\beta} - e)}{\bar{\beta}}$$

$$H_c = H - H_b$$

*Reference DG29

Session 5: Vertical Bracing Connections 104

Brace to Base

- General Work Point FBD

Note: $e_c = 0$ in. to column webs

$$H = P \sin \theta$$

$$V = P \cos \theta$$

$$V_c = V$$

$$H_b = \frac{H(\bar{\beta} - e) - Ve_c}{\bar{\beta}}$$

$$H_c = H - H_b$$

*Reference DG29

Session 5: Vertical Bracing Connections

105

Brace to Base

- General Work Point FBD

$$H = P \sin \theta$$

$$V = P \cos \theta$$

$$V_c = V$$

$$H_b = \frac{H(\beta - e) - Ve_c}{\beta}$$

$$H_c = H - H_b$$

Can also determine H_c by summing moments about face of column flange at base plate:

$$H_c = \frac{H(e) + V(e_c)}{\beta}$$

*Reference DG29

Session 5: Vertical Bracing Connections

106



Brace to Base

- General Work Point FBD

$$\beta = 0.5(L_{weld_c}) + clip$$

Session 5: Vertical Bracing Connections 107

Brace to Base

- Work Point location – Top of Plate

$$V_c = P \sin \theta_h$$

$$M_c = V_c (e_c)$$

$$H_b = P \cos \theta_h$$

Session 5: Vertical Bracing Connections 108



Brace to Base

- Check anchor rods for shear and bending if washer plate is welded to base plate
- Base plate hole size per 15TH Ed. Manual Table 14-2
- Washer plates per 15TH Ed. Manual Table 14-2
- Consider lugs if high shear load and column has insufficient compression to resist the shear in friction

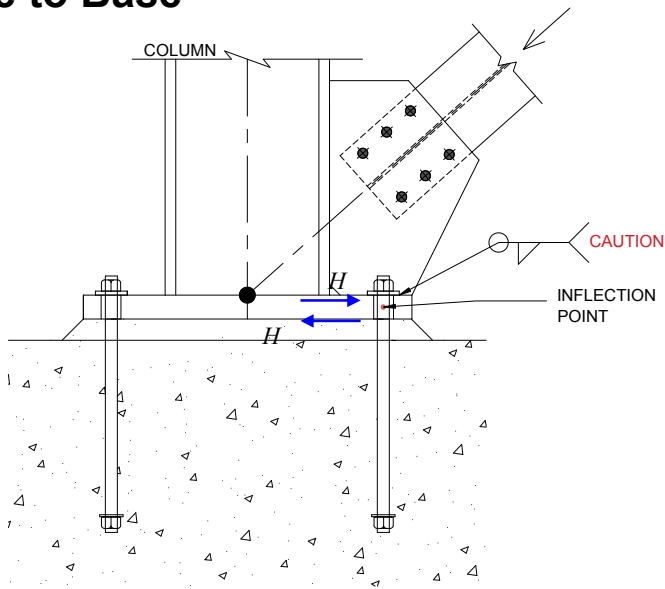

Session 5: Vertical Bracing Connections

109

Tension Column Splices

- Typical order of preference:
 - Bolted
 - PJP welded
 - CJP welded
- SC Bolts or Bearing
- Avoid full strength, especially welded
- Show loads on Column Schedule or Braced Frame elevations

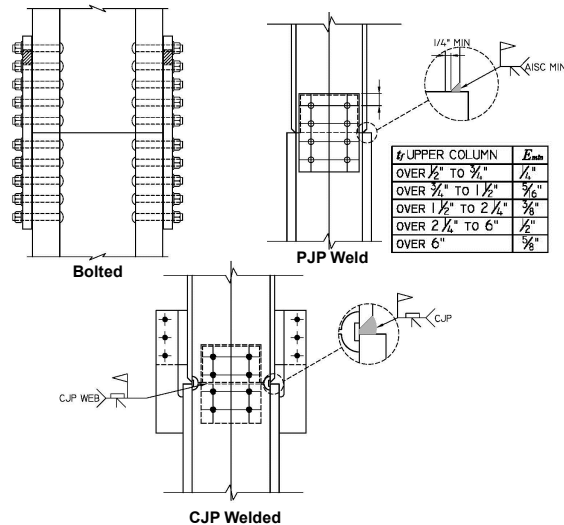

Session 5: Vertical Bracing Connections

110



Lateral Column Splices

- CJP versus PJP
 - Testing
 - Gap
- Land = 1/4" Min. PJP
- Use similar column depths for alignment of flanges. W14 columns preferred. For column size W14:
 $d - 2t_f = 12.6"$

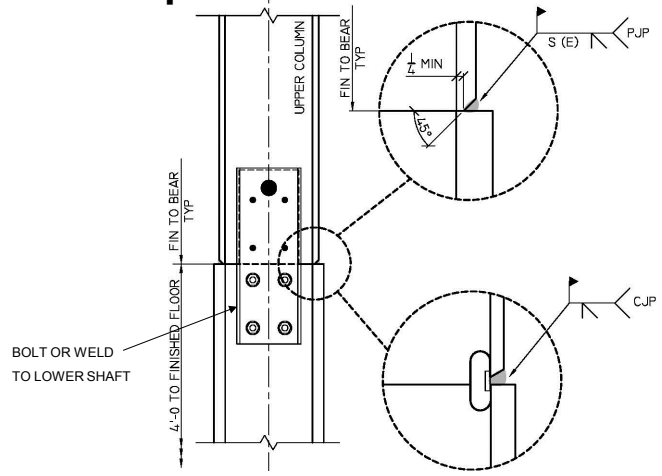

Note: Weld prep should allow for flange tilt when $d_{c1} - d_{c2} < 1/4"$



Welded Tension Column Splices

Step 1: Check for Tension using S and P_{min} :

$$f_a = \frac{P_{min}}{A_g} - \frac{M_x}{S_x} - \frac{M_y}{S_y}$$

Step 2: If tension, determine stresses in weld

$$f_x = \frac{V_x}{(2)(L_{weld})} + \frac{Torsion}{(d)(L_{weld})}$$

$$f_y = \frac{P_{min, flange}}{(2)(L_{weld})} - \frac{M_x}{(d - \frac{t_f}{2})(L_{weld})} - \frac{4M_y}{(2)(L_{weld})^2}$$

Step 3: Determine (E) required for shear and axial:

$$(E) = \frac{f}{(\phi)(0.6F_{EXX})}$$

Step 4: Sum squares and compare to AISC min. (Table J2.3)

$$E_{min} = \sqrt{(E_{min(shear)})^2 + (E_{min(tension)})^2}$$

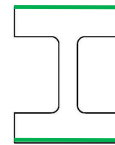

Seismic Splices: AISC Seismic Provisions 341-16 OCBF, SCBF, BRBF (D2.5 and Chapter F)

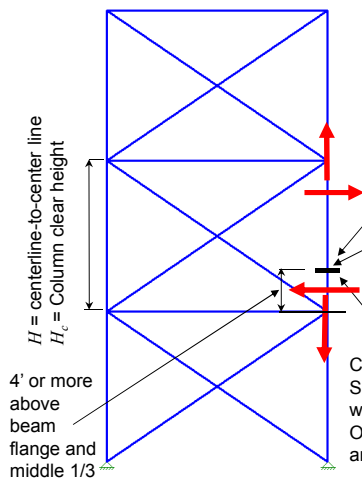

Web Shear = maximum required per load combinations or

1. $V = M_{pc}/H$ (OCBF)
2. $V = \sum M_{pc}/H_c$ (Bolted SCBF/BRBF)
 $F_y(Z_u + Z_l)/(H - d_{bd}/2 - d_{bd}/2 - t_{stab,l})$

Note: LRFD expressions shown

D2.5b: If tension using overstrength seismic loads:

1. PJP welds develop 200% required strength
2. Must develop $0.5R_y F_y b_f t_f$ of the smaller flange

Chapter F:
 SCBF/BRBF: CJP or Bolted flanges with min strength = $0.5R_y F_y Z_{x,min}$
 OCBF: Load Combinations with amplified loads

- Demand critical welds
- Weld tabs to be removed, steel backing of groove welds need not be removed
- If tension $> 0.3F_y$ at smaller column, taper transitions of t_f



Seismic Splices: 341-16 Column Not Part of the SFRS (D2.5)

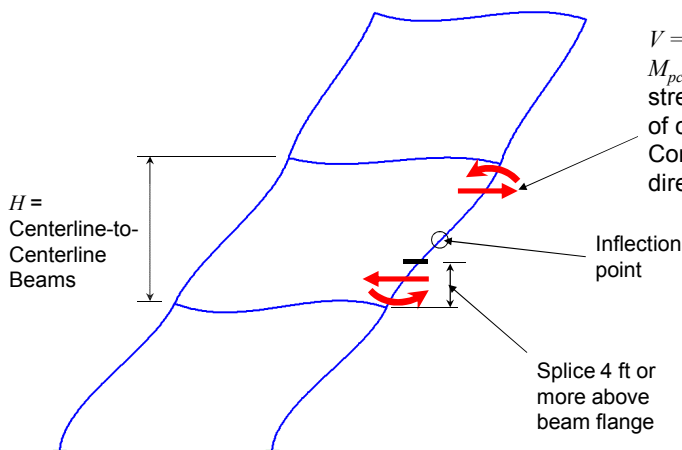

$V = M_{pc}/H$
 M_{pc} = plastic flexural strength in direction of consideration. Consider both directions

Use shear equal to $1/2$ of $2M_{pc}/H$



Seismic Bracing

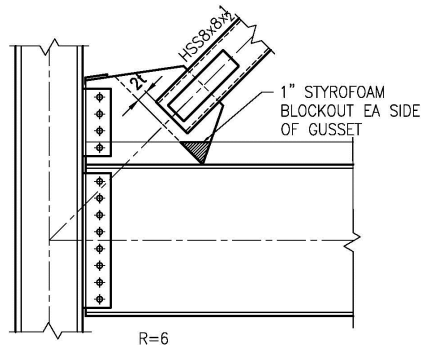

- SCBF – Expected strength
- OCBF – Expected tension strength need not exceed the overstrength seismic load
- BRBF – Buckling-Restrained Braced
- EBF - Eccentrically Braced Frame



Session 5: Vertical Bracing Connections

115

OCBF

- Per AISC's 341-16 Section F1.6, the bracing connections shall be designed for the minimum of :
 - i. Force from ASCE7-16 Section 12.4.3.2 with Overstrength Factor, Ω_o .
 - ii. The expected tension strength of the brace, $R_y F_y A_g / \alpha_s$

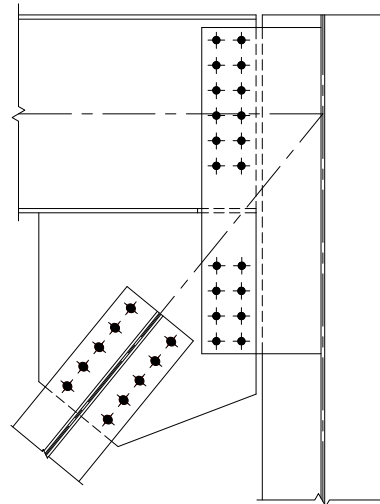

Session 5: Vertical Bracing Connections

116

OCBF

6. Connections
6a. Brace Connections

The required strength of diagonal brace connections shall be determined using the overstrength seismic load.

Exception: The required strength of the brace connection need not exceed the following.

- (a) In tension, the expected yield strength divided by α_s , which shall be determined as $R_y F_y A_g / \alpha_s$, where $\alpha_s =$ LRFD-ASD force level adjustment factor = 1.0 for LRFD and 1.5 for ASD.
- (b) In compression, the expected brace strength in compression divided by α_s , which is permitted to be taken as the lesser of $R_y F_y A_g / \alpha_s$ and $1.1 F_{cre} A_g / \alpha_s$, where F_{cre} is determined from *Specification* Chapter E using the equations for F_{cr} , except that the expected yield stress, $R_y F_y$, is used in lieu of F_y . The brace length used for the determination of F_{cre} shall not exceed the distance from brace end to brace end.
- (c) When oversized holes are used, the required strength for the limit state of bolt slip need not exceed the seismic load effect based upon the load combinations without overstrength as stipulated by the applicable building code.

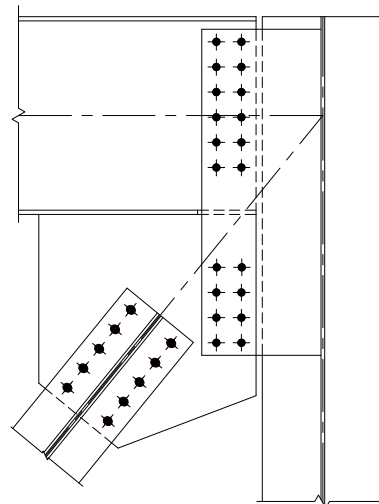

OCBF

- ASCE 7-16 Section 12.4.3.1 Overstrength load combinations are (LRFD):

Where the seismic load effect with overstrength, $E_m = f(E_v, E_{mh})$, defined in Section 12.4.3, is combined with the effects of other loads, the following seismic load combination for structures shall be used:

- 6. $1.2D + E_v + E_{mh} + L + 0.2S$
- 7. $0.9D - E_v + E_{mh}$

12.4.3.1 Horizontal Seismic Load Effect Including Overstrength. The effect of horizontal seismic forces including overstrength, E_{mh} , shall be determined in accordance with Eq. (12.4-7) as follows:

$$E_{mh} = \Omega_0 Q_E \quad (12.4-7)$$

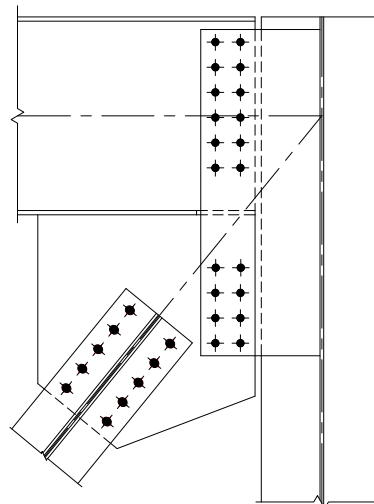

OCBF

- ASCE 7-16, Table 12.2-1, Overstrength Factor, Ω_o

Table 12.2-1 Design Coefficients and Factors for Seismic Force-Resisting Systems

Seismic Force-Resisting System	ASCE 7 Section Where Detailing Requirements Are Specified	Response Modification Coefficient, R^a	Overstrength Factor, Ω_o^b	Deflection Amplification Factor, C_d^c
B. BUILDING FRAME SYSTEMS				
1. Steel eccentrically braced frames	14.1	8	2	4
2. Steel special concentrically braced frames	14.1	6	2	5
3. Steel ordinary concentrically braced frames	14.1	3/4	2	3/4
4. Special reinforced concrete shear walls ^{g,h}	14.2	6	2 1/2	5
5. Ordinary reinforced concrete shear walls ^g	14.2	5	2 1/2	4 1/2
6. Detailed plain concrete shear walls ^g	14.2 and 14.2.2	2	2 1/2	2



Things to Look for in Review

- Notes:
 - Correct Forces ✓
 - Correct Member Sizes ✓
 - Correct Spec and ASD/LRFD ✓
 - Correct Work Point
 - Confirm e_c
 - Confirm any special requirements met
 - Hole type consistent with bolt type
 - Hc force using the UFM applied at beam-to-column connection
 - Transfer forces included in design

Given:

- References: AISC Specification for Structural Steel Building, AISC 360-10
AISC Manual 14th Edition
- Design Basis: ASD design := "ASD"
- Materials:
 - W-Shaped:
 - HSS: $F_{y,w} := 50 \text{ ksi}$ $F_{u,w} := 65 \text{ ksi}$
 - Plate: $F_{y,pl} := 46 \text{ ksi}$ $F_{u,pl} := 58 \text{ ksi}$
 - Angle: $F_{y,an} := 36 \text{ ksi}$ $F_{u,an} := 58 \text{ ksi}$
- Bolts:
 - 3/4"-dia. A325-N bolts $d_{bolt} := \frac{3}{4} \text{ in}$



Things to Look for in Review

- Notes:

- Demand capacity ratio (DCR) < 1 ✓
- Correct bolt values
- Incomplete design

$$U_{whit_c} := \text{abs} \left(\frac{P_c}{\phi P_{n_c}} \right) = 0.627$$

if ($U_{whit_c} > 1$, "n.g.", "o.k.") = "o.k."

$$U_{whit_t} := \text{abs} \left(\frac{P_t}{\phi P_{n_t}} \right) = 0.573$$

if ($U_{whit_t} > 1$, "n.g.", "o.k.") = "o.k."

CONNECTION IS OK
(Strength equals or exceeds design loads)



Conclusion

- Give actual forces on contract documents
- Avoid specifying unnecessary requirements that could penalize the contractor.
- Coordinate with other team members for most efficient design.
- Provide all information needed to properly complete connection design.



AISC | Questions?



**Smarter.
Stronger.
Steel.**

Individual Session Registrants

CEU / PDH Certificates

- You will receive an email on how to report attendance from:
registration@aisc.org.
- Be on the lookout: Check your spam filter! Check your junk folder!
- Completely fill out online form. Don't forget to check the boxes next to each attendee's name!



**Smarter.
Stronger.
Steel.**

Individual Session Registrants

CEU / PDH Certificates

- Reporting site (URL will be provided in the forthcoming email).
- Username: Same as AISC website username.
- Password: Same as AISC website password.



Smarter.
Stronger.
Steel.

8-Session Registrants

CEU / PDH Certificates

One certificate will be issued at the conclusion of all 8 sessions.



Smarter.
Stronger.
Steel.

8-Session Registrants

Access to the quiz

Information for accessing the quiz will be emailed to you by Wednesday. It will contain a link to access the quiz. EMAIL COMES FROM NIGHTSCHOOL@AISC.ORG.

Quiz and attendance records

Posted Tuesday mornings. www.aisc.org/nightschool -- Click on Current Course Details.

Reasons for quiz

- EEU – You must take all quizzes and the final exam to receive EEU.
- CEUs/PDHs – If you watch a recorded session, you must pass quiz for CEUs/PDHs.
- REINFORCEMENT – Reinforce what you learn tonight. Get more out of the course.

Note: If you attend the live presentation, you do not have to take the quizzes to receive CEUS/PDHs



Smarter.
Stronger.
Steel.

8-Session Registrants

Access to the recording

Information for accessing the recording will be emailed to you by Wednesday. The recording will be available for three weeks. (For 8-session registrants only.) EMAIL COMES FROM NIGHTSCHOOL@AISC.ORG.

CEUs / PDHs via recording

If you watch a recorded session, you must take *and pass* the quiz for CEUs/PDHs.



Smarter.
Stronger.
Steel.

8-Session Registrants

Night School Resources

Find all your handouts, quizzes and quiz scores, recording access, and attendance information all in one place!



8-Session Registrants

Night School Resources

Go to www.aisc.org and sign in.



Login

If you're an existing customer, please enter your username and password.

USERNAME
Enter your username

PASSWORD
Enter your password

Remember Me

DON'T HAVE AN ACCOUNT?
My AISC allows you to access Engineering Journal articles and Design Guides you have downloaded from the bookstore.

[REGISTER NOW](#)



8-Session Registrants

Night School Resources

Go to www.aisc.org and sign in.

IN THIS SECTION

- Edit Profile
- My Downloads
- My Pending Quizzes
- My Events
- Order History
- Course History
- Course Resources**

MyAISC

MY PROFILE
Update your contact and address information.

[EDIT PROFILE](#)

MY PURCHASED DOWNLOADS
Access articles and documents that you have purchased.

[VIEW DOWNLOADS](#)

MY COURSE RESOURCES
View online resources for Night School and Live Webinar package registrations.

[VIEW RESOURCES](#)



**Smarter.
Stronger.
Steel.**

8-Session Registrants

Night School Resources



[EDUCATION](#)
[PUBLICATIONS](#)
[NASCC: THE STEEL CONFERENCE](#)
[STEEL SOLUTIONS CENTER](#)
[AWARDS AND COMPETITIONS](#)
[TECHNICAL RESOURCES](#)



AISC

[AISC](#) > [MYAISC](#) > [COURSE RESOURCES](#)

Course Resources

Event	Start Date
NS 12 8-Session Package-Night School 12 - Design of Industrial Buildings	1/30/2017 7:00:00 PM
NS 14 8-Session Package-Night School 14 - Fundamentals of Stability	6/5/2017 7:00:00 PM



**Smarter.
Stronger.
Steel.**



8-Session Registrants

Night School Resources



Night School 13: Design of Industrial Buildings

8-SESSION PACKAGE RESOURCES

Event	Date	Handouts	Video	Quiz	Attendance
NS13 - Design Criteria	1/30/2017 7:00:00 PM	Handouts	View Passcode: NS13DSN	Pass Score: 80	Pending
NS13 - Economic Considerations	2/6/2017 7:00:00 PM	Handouts	Available 02/08/2017 5pm EST	Available 02/08/2017 5pm EST	Pending
NS13 - Lateral Load Systems and Details	2/13/2017 7:00:00 PM	Handouts	Available 02/15/2017 5pm EST	Available 02/15/2017 5pm EST	Pending
NS13 - Preliminary Design Procedures	2/27/2017 7:00:00 PM	Handouts	Available 03/01/2017 5pm EST	Available 03/01/2017 5pm EST	Pending
NS13 - Crane Girder Design and Frame Analysis	3/6/2017 7:00:00 PM	Handouts	Available 03/08/2017 5pm EST	Available 03/08/2017 5pm EST	Pending
NS13 - Frame Member and Connection Design	3/13/2017 7:00:00 PM	Handouts	Available 03/15/2017 5pm EST	Available 03/15/2017 5pm EST	Pending
NS13 - Transfer Crane Girder & Longitudinal Bldg Bracing Dsn	3/27/2017 7:00:00 PM	Handouts	Available 03/29/2017 5pm EST	Available 03/29/2017 5pm EST	Pending



**Smarter.
 Stronger.
 Steel.**

8-Session Registrants

Night School Resources

- Weekly “quiz and recording” email.
- Weekly updates of the master quiz and attendance record, found at www.aisc.org/nightschool19. Scroll down to Quiz and Attendance records.
 - Updated on Tuesday mornings.



**Smarter.
 Stronger.
 Steel.**



8-Session Registrants

Night School Resources

- Webinar connection information
 - Found in your registration confirmation / receipt
 - Reminder email sent out Monday mornings
- Links to handouts also found here



Smarter.
Stronger.
Steel.



AISC | Thank you



Smarter.
Stronger.
Steel.