

Thank you for joining our live webinar today.

We will begin shortly.
Please standby. Thank you.

Need Help?
Call ReadyTalk Support:
800.843.9166

**AISC**
Night School



Connection Design

Tips, Tricks, and Lessons Learned



Smarter.
Stronger.
Steel.

**AISC**
Night School

Audio Options

Today's audio will be broadcast through the internet.

Alternatively, to hear the audio through the phone, dial:

(866)-519-2796
Passcode: 324420



Smarter.
Stronger.
Steel.



Today's live webinar will begin shortly. Please stand by.

As a reminder, all lines have been muted. Please type any questions or comments through the chat feature on the left portion of your screen.

Today's audio will be broadcast through the internet.
Alternatively, to hear the audio through the phone, dial:

(866)-519-2796
Passcode: 324420



AIA Credit

AISC is a Registered Provider with The American Institute of Architects Continuing Education Systems (AIA/CES). Credit(s) earned on completion of this program will be reported to AIA/CES for AIA members. Certificates of Completion for both AIA members and non-AIA members are available upon request.

This program is registered with AIA/CES for continuing professional education. As such, it does not include content that may be deemed or construed to be an approval or endorsement by the AIA of any material of construction or any method or manner of handling, using, distributing, or dealing in any material or product.

Questions related to specific materials, methods, and services will be addressed at the conclusion of this presentation.





Copyright Materials

This presentation is protected by US and International Copyright laws. Reproduction, distribution, display and use of the presentation without written permission of AISC is prohibited.

© The American Institute of Steel Construction 2019

The information presented herein is based on recognized engineering principles and is for general information only. While it is believed to be accurate, this information should not be applied to any specific application without competent professional examination and verification by a licensed professional engineer. Anyone making use of this information assumes all liability arising from such use.



Course Description

19.8 Lessons Learned
April 8, 2019

In this session, the speakers will share stories, from their respective careers, that have shaped their views on how delegated connection design can be successfully implemented on structural steel projects. The speakers will use real-life case studies and examples to illustrate the importance of teamwork and communication in the construction industry.





Learning Objectives

- Explain how a flexible bidding process can ensure that all parties have the same understanding on a construction project.
- List key components of an effective design-assist relationship between engineers of record and fabricators / connection designers, and how they can lead to economical and safe connections.
- Explain the importance of the engineer of record having awareness of special design requirements, and clearly communicating those special requirements to the construction team.
- Describe procedures to follow when unsafe conditions are found during construction.



Night School 19 Connection Design: Tips, Tricks, and Lessons Learned

Session 8: Lessons Learned
April 8, 2019



Patrick J. Fortney, PhD, PE, SE



Larry S. Muir, PE



William A. Thornton, PhD, PE, NAE



Some Lessons Learned

- Communication is the key.
- The *Code of Standard Practice* provides a foundation for effective communication.
- The fabricator and connection designer should work as a unit.
- Provide actual loads.
- Do not make up requirements.
- Verify do not guess.

9

Lessons Learned in the Trenches

The following stories are meant to illustrate how the delegated design process and communications between the parties either worked to provide good outcomes or broke down resulting in challenges that had to be overcome.

10



1. Imagined

11

Misty Water-Colored Memories

In Session 2 of this Night School Cliff Schwinger cautioned against the use of made-up requirements.

12



Misty Water-Colored Memories

In Session 3 of this Night School Pat Fortney advised fabricators and delegated connection designers not to guess but to verify.

13

Misty Water-Colored Memories

Let's see these ideas in practice.

14



Some Project Specifics

- Power plant in a high-seismic area (Special Concentrically Braced Frames)
- A unit price project
- Neither the Engineer nor the Owner were familiar with the *Seismic Provisions* or the potential cost associated with meeting its requirements.

15

Some Project Specifics

- The owner was very concerned with cost.
- The Engineer of Record actively sought cost-saving ideas from the fabricator.
- The Engineer of Record rejected virtually all cost-saving ideas from the fabricator.
- The Engineer of Record imposed “imagined” requirements and took a very rigid approach to code requirements.

16



Interpretations and Imaginations

Example of Imagined Requirement:

Vertical brace connections shall be stiffened.

17

Interpretations and Imaginations

1. Stiffened where?
2. What is the load?
3. How thick should the stiffener be?
4. How should it be welded?

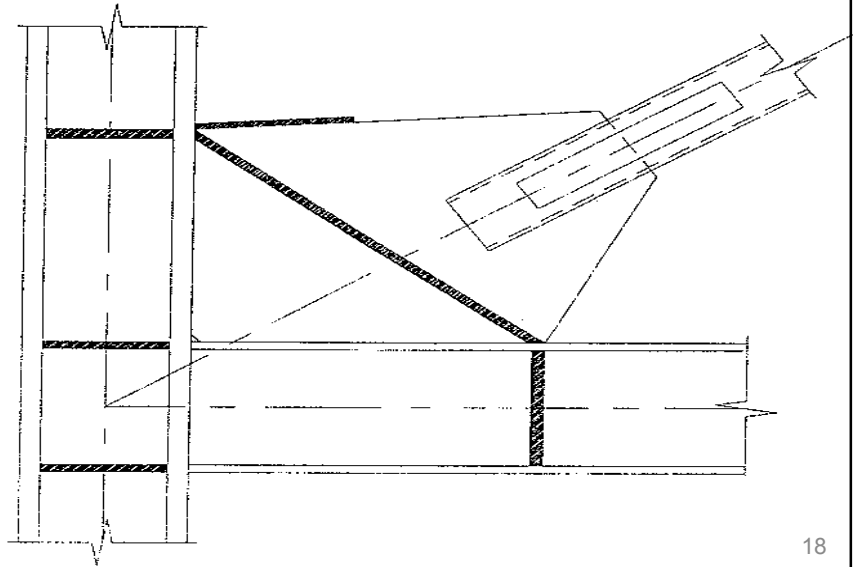

18

Interpretations and Imaginations

1. Stiffened where?

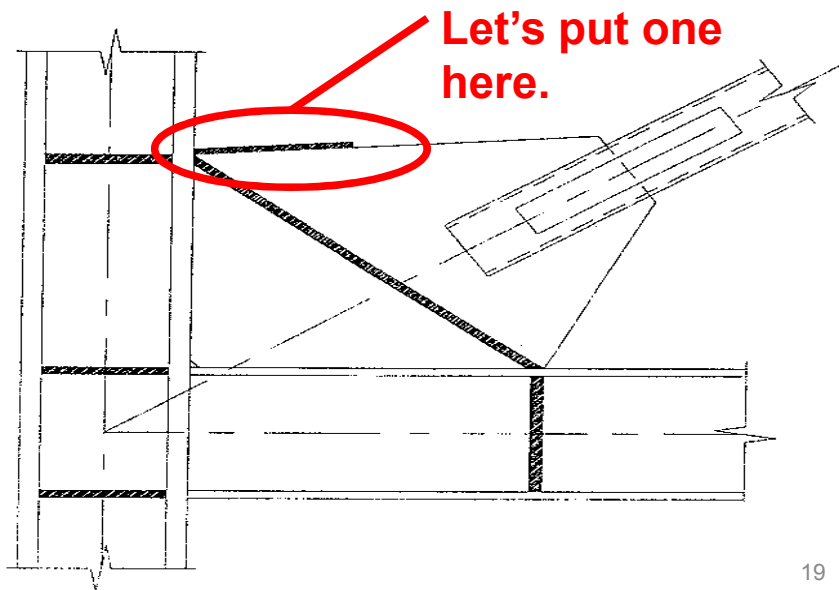

19

Interpretations and Imaginations

2. What is the load?

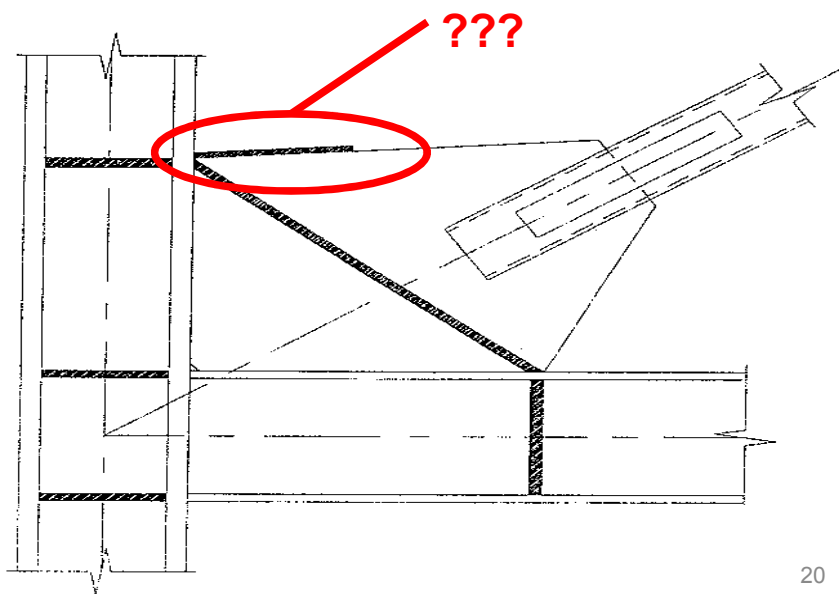

20

Interpretations and Imaginations

3. How thick should the stiffener be?

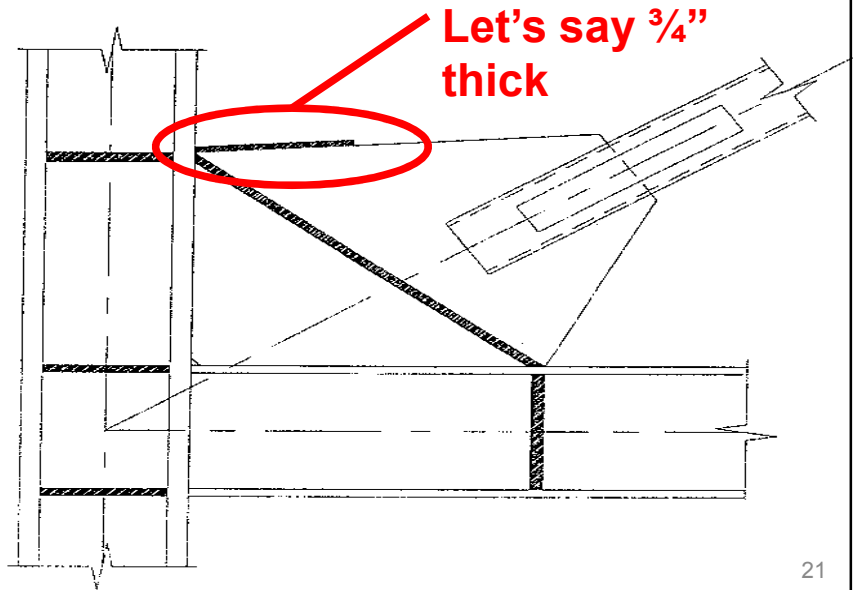

Interpretations and Imaginations

4. How should it be welded?

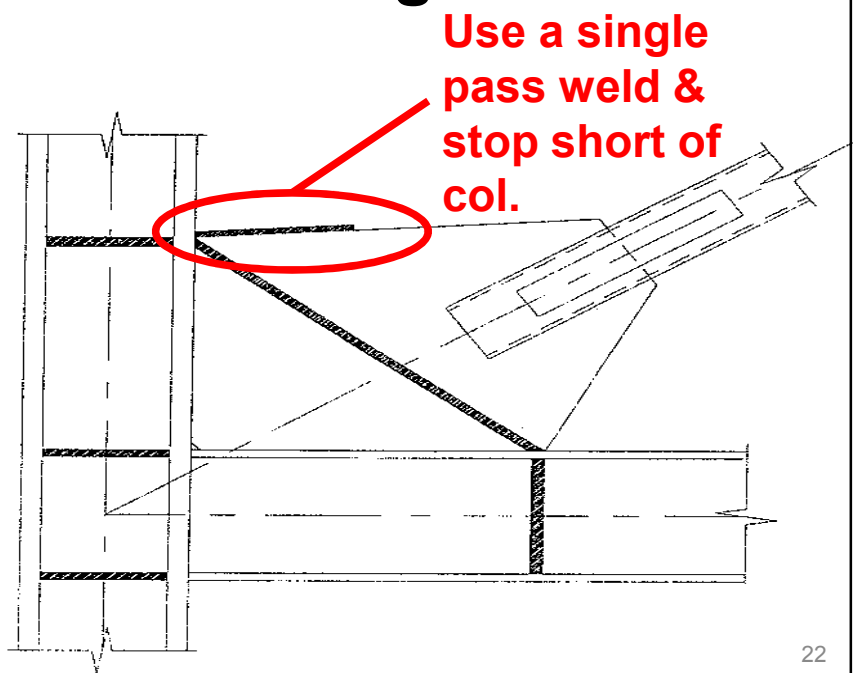

Interpretations and Imaginations

- In some cases the bevel was more like this and the stiffener resembled a cube $\frac{3}{4}'' \times \frac{3}{4}'' \times \frac{3}{4}''$.
- The benefit was difficult to quantify, but the cost was not.

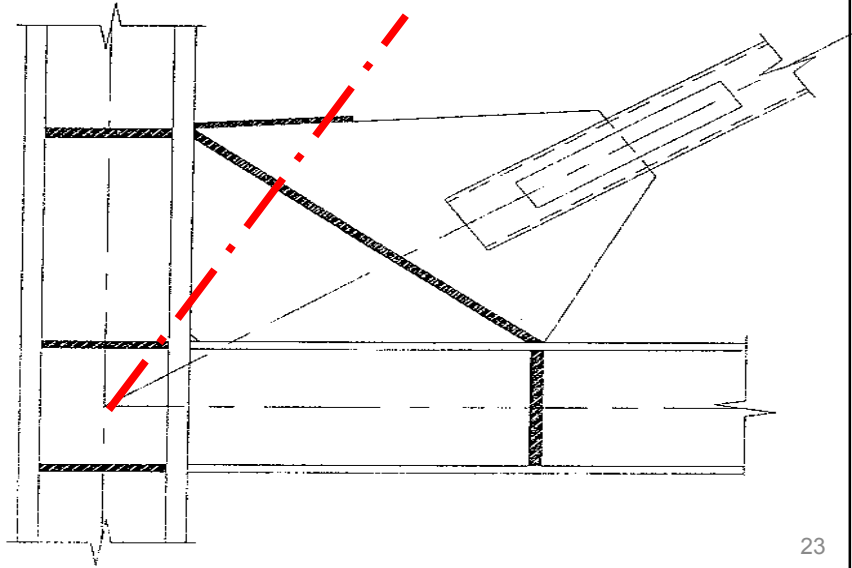

Interpretations and Imaginations

RINSE AND REPEAT

24

Interpretations and Imaginations

1. Stiffened where?

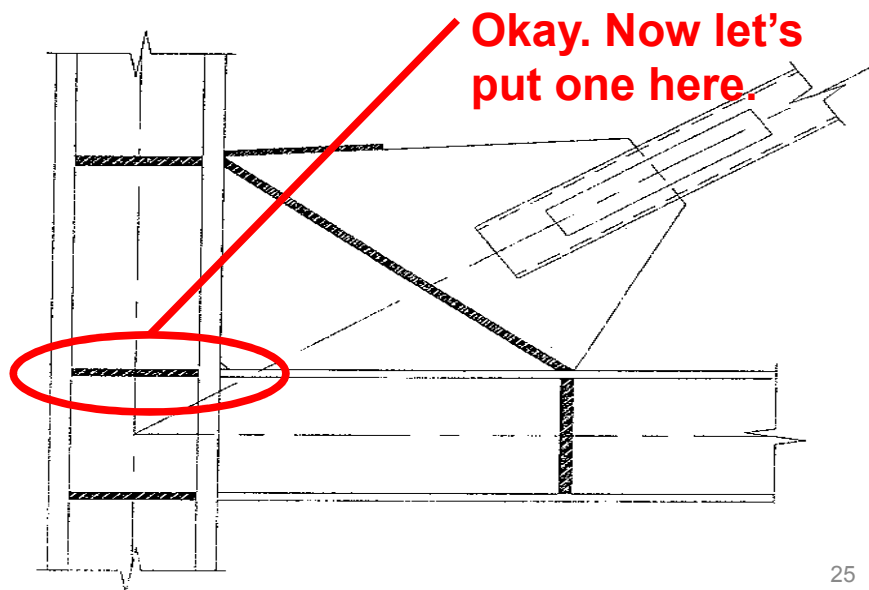

Interpretations and Imaginations

- If as the Engineer of Record you are going to make-up requirements follow through to develop clear project-specific requirements.
- There is no way to account for made-up requirements during bidding unless they are clearly defined in the contract documents. If they are not clearly defined in the contract documents, they will be a change to the contract.

26

Interpretations and Imaginations

As the connection design engineer when imaginary requirements are imposed:

- Point out the discrepancy.
- Make the EoR clearly define what is required. **DO NOT GUESS.**
- Document the change.
- Evaluate cost and schedule impacts as indicated in the COSP.

27

Post-Mortem

- The EoR asked the Fabricator to help them explain to the Owner why this project had cost multiples of similar past projects.
- Some of the increased cost could be explained by the inherent costs associated with satisfying the *Seismic Provisions*.

However...

28



Post-Mortem

... much of the cost was directly attributable to imagined requirements and interpretations the Engineer chose to make.

29

1. Imagined

Lessons Learned

- If Engineer of Record has special project requirements, those should be clearly defined.
- There is no way to account for special project requirements during bidding unless they are clearly defined.
- Connection designers should point out discrepancies and make the Engineer of Record clearly define what is required.

30



2. Design Assist: When it Works



31

Teamwork

Design Assist

"If everyone is moving forward together,
then success takes care of itself."

~Henry Ford

32



Teamwork

Design Assist

When it Works

33

Teamwork

Design Assist

- Really!

So, the SEoR wants pre-bid meetings with the fabricator to discuss design assist in regard to connection design



34

Teamwork

Design Assist

- Really!

So, the SEoR wants pre-bid meetings with the fabricator to discuss design assist in regard to connection design

The SEoR, fabricator, connection designer, and erector bring specialized and critical skills to a project



35

Teamwork

Design Assist

- Really!

So, the SEoR wants pre-bid meetings with the fabricator to discuss design assist in regard to connection design

The SEoR, fabricator, connection designer, and erector bring specialized and critical skills to a project



Each brings an important piece of the puzzle!

36

Teamwork



Teamwork

Design Assist

- Really!

SEoR wants to meet prospective fabricators during bid process to discuss connection design and potential for collaboration

Intent is to finalize structural design with input from erectors and connection designers



38

Teamwork

Design Assist

- Really!

This proved to be a wholesome offer

SEoR finalized structural design based on collaboration with the erector and connection designer

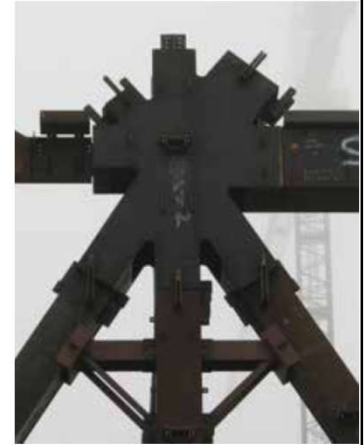
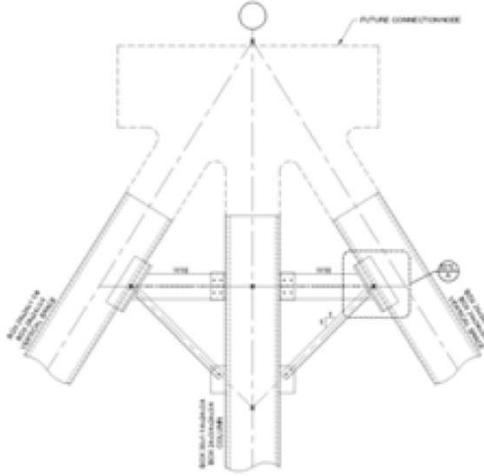

39

Teamwork

Design Assist

- Really!

Clear, concise engineering sketches to communicate with SEoR, fabricator, and detailer

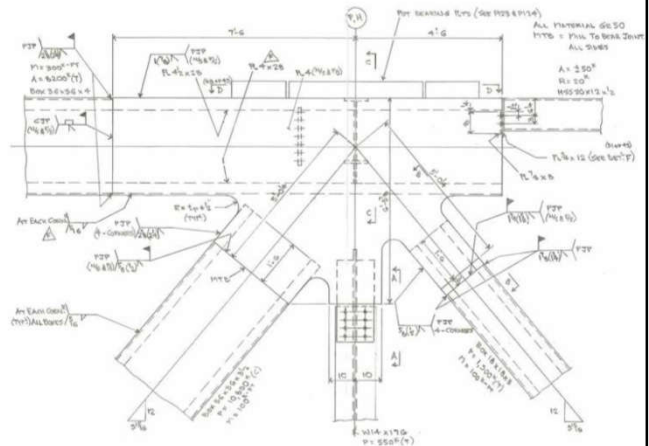

40

Teamwork

Design Assist

- Really!

Nodal approach led to the SEoR performing several iterations of analysis and redesign to accommodate type of connections

The SEoR was willing to take this approach



41

Teamwork

Design Assist

- Really!

Iterations of analysis with changes in boundary conditions led to additional combined connection design loads

The connection designer was willing to take this approach



42

Teamwork

Design Assist

- Really!

Most all of the nodal connections used mill-to-bear joints to transfer large brace forces in the range of 10,000 to 20,000 kips

Fabricator and erector worked closely with each other to ensure fit-up



43

Teamwork

Design Assist

- Really!

Original design documents required all built-up members to be joined with CJP welds

With input from connection designer, approximately \$2M was saved by using combinations of fillet, PJP, and CJP welds where appropriate



44

Teamwork

Design Assist

- Really!

SEoR, fabricator, and erector collaborated continually throughout design phase.

Each bring value engineering and compromise for the good of the project



Teamwork

Design Assist

- Really!
- ~11,000 tons of fabricated steel,
- 72 nodal connections weighing as much as 25 tons each
- ~8 miles of linear welds on built-up shapes
- 14-member nodes



1 fit-up problem that required rework (early in erection)
on entire project

46

Teamwork

Design Assist

- Really!

Teamwork,
Clear and effective communication,
Compromise

Successful project from every
perspective



Each brings an important piece of the puzzle!

47

2. Design Assist: When it Works

Lessons Learned

- The talents and skills of all parties are critical to the success of a project.
- Respect for each other is crucial.
- Trust in our colleagues and counterparts is crucial.
- Open and clear conversation between parties is crucial.
- This is a give and take process and reasonable compromises must be made.
- Everyone benefits in a healthy team environment.



48

2. Design Assist: When it Works

Poll Question



49

3. Clear and Present Danger



50



Some Project Specifics

- An outdoor theater accommodating about 15,000 spectators.
- A tight schedule constrained by an “opening day” concert.
- Propped cantilever beams supporting seating.



51

General Layout

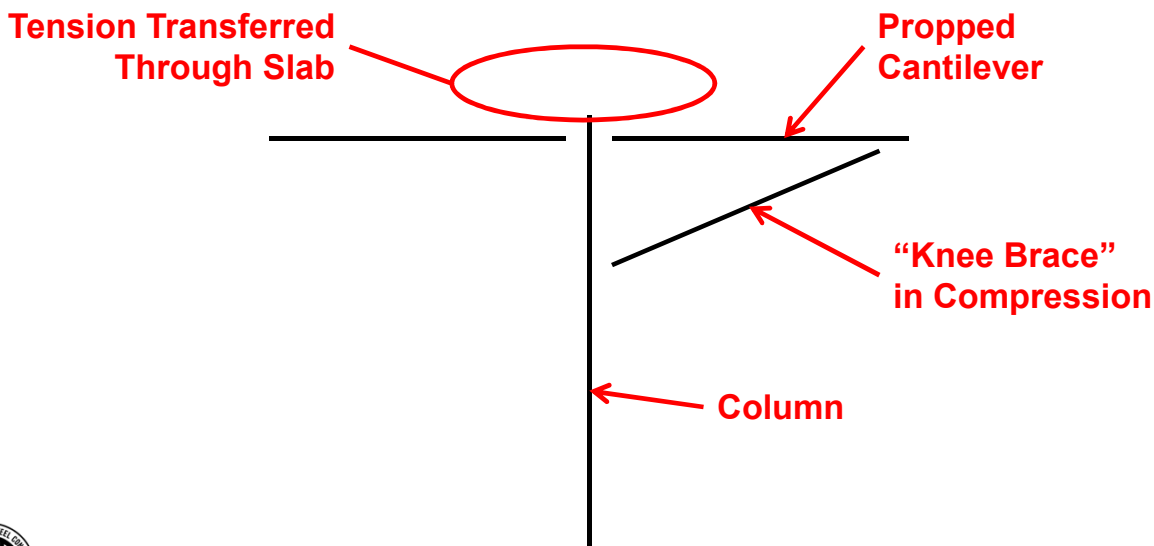

52



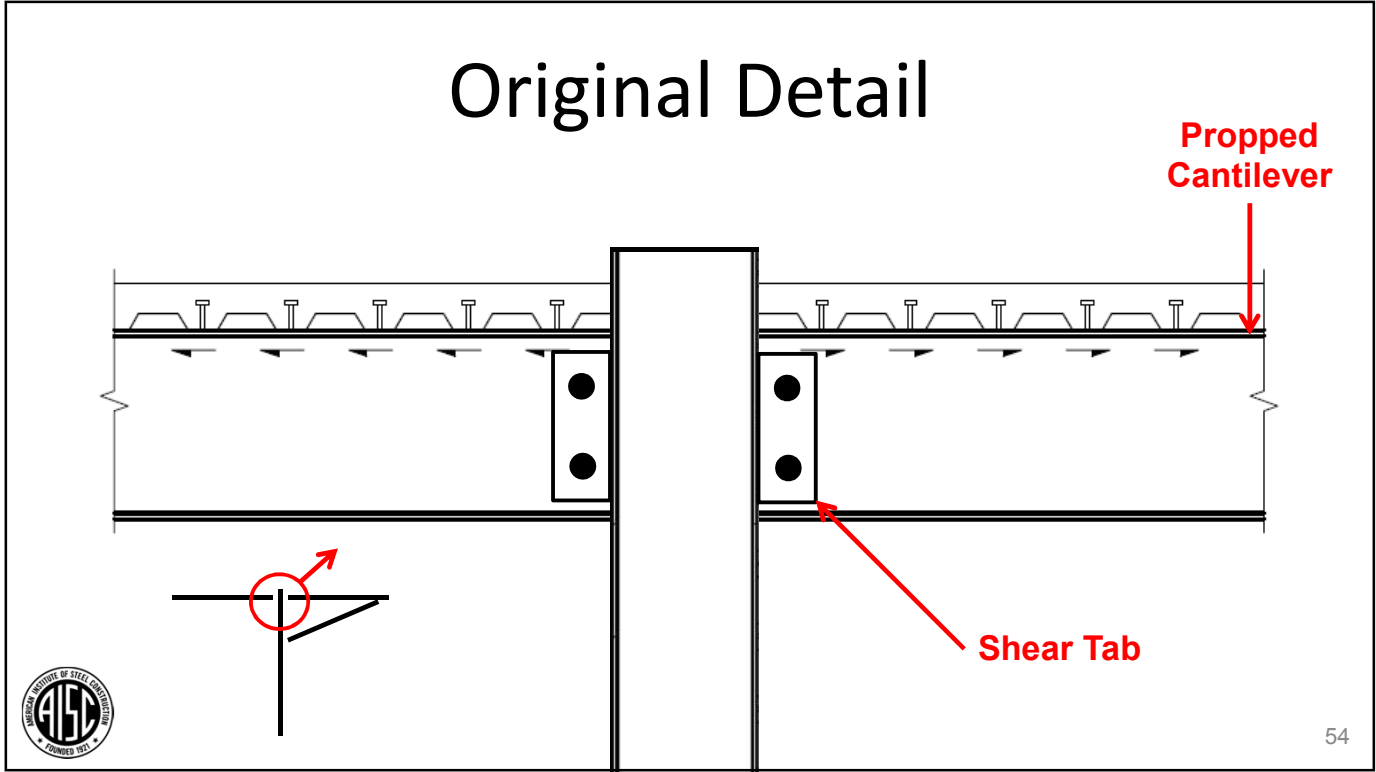
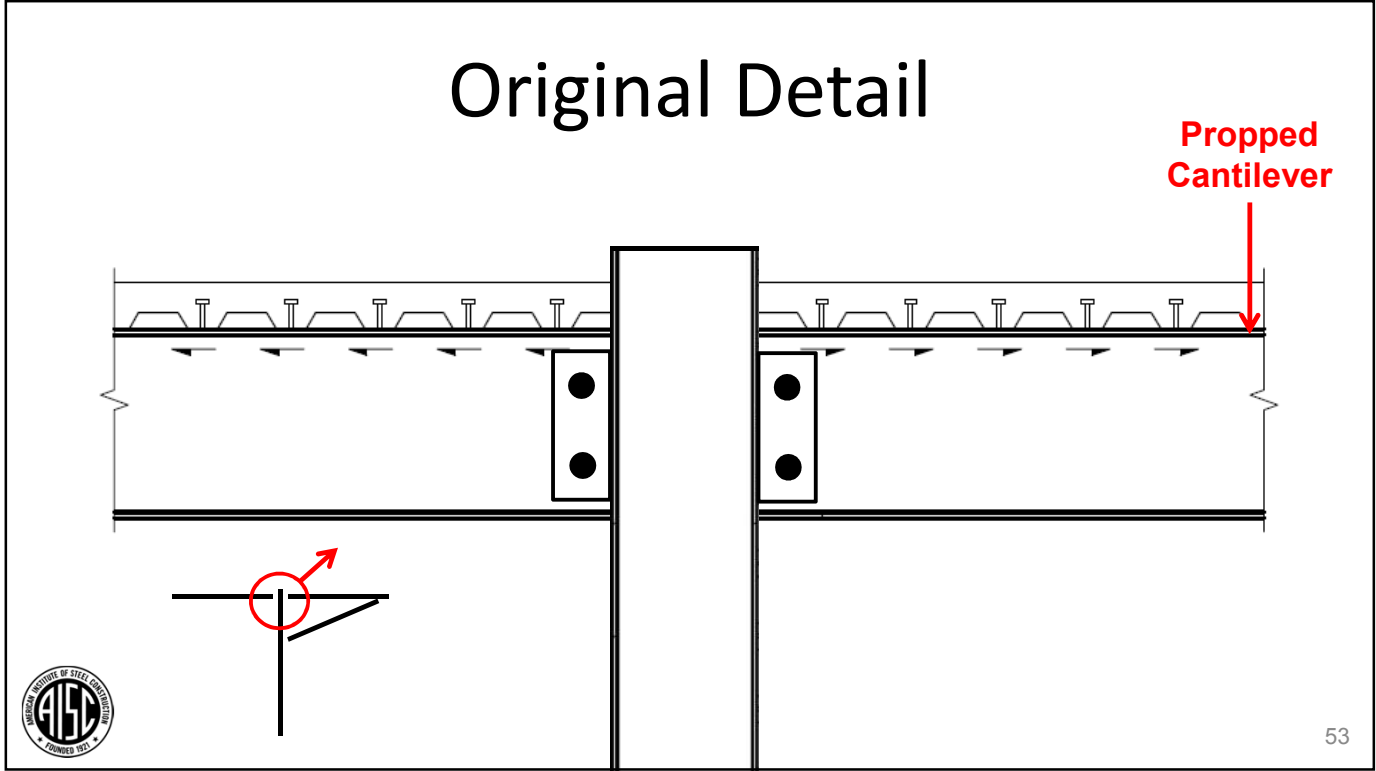

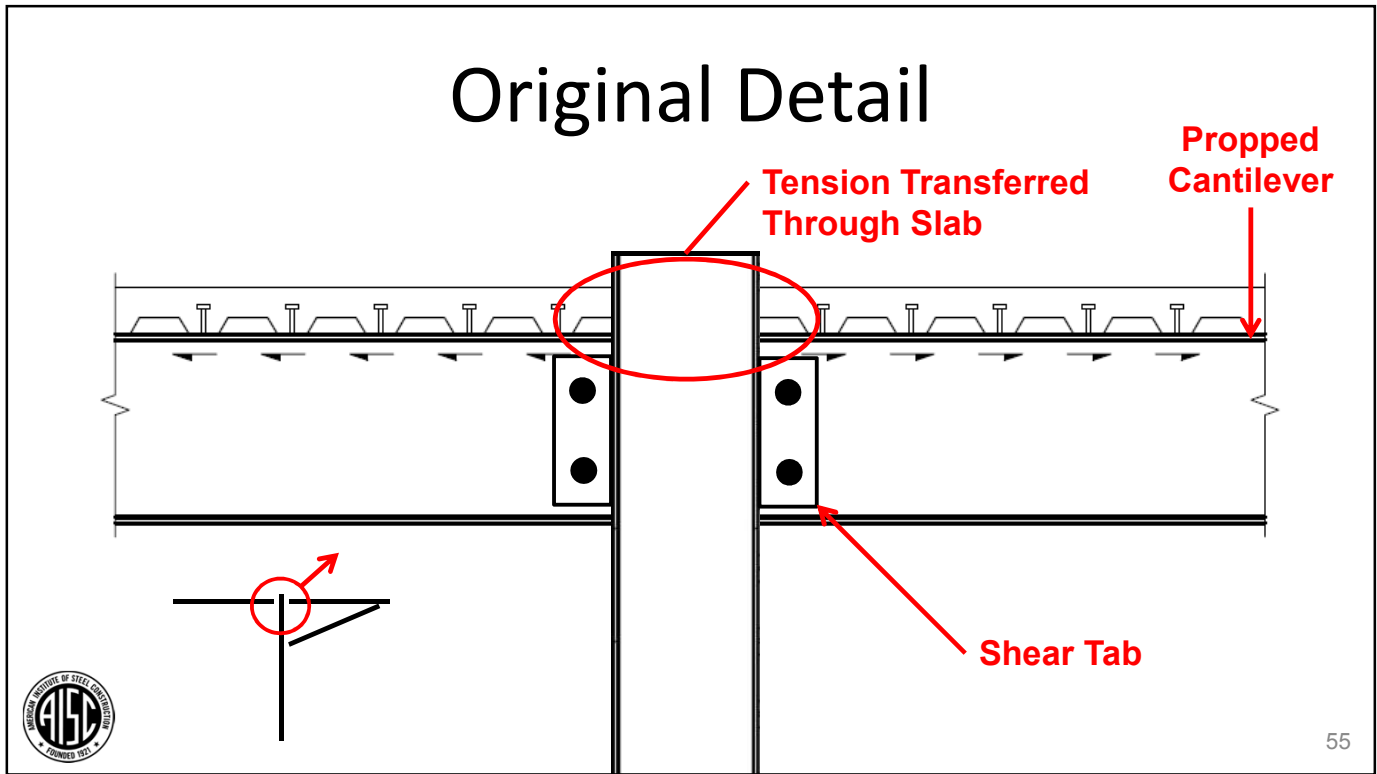

Let's Add Some Value!!!



Relatively late in the project someone suggested that money could be saved by replacing the cast-in-place slab with precast planks.

The Engineer of Record approved the change.



56

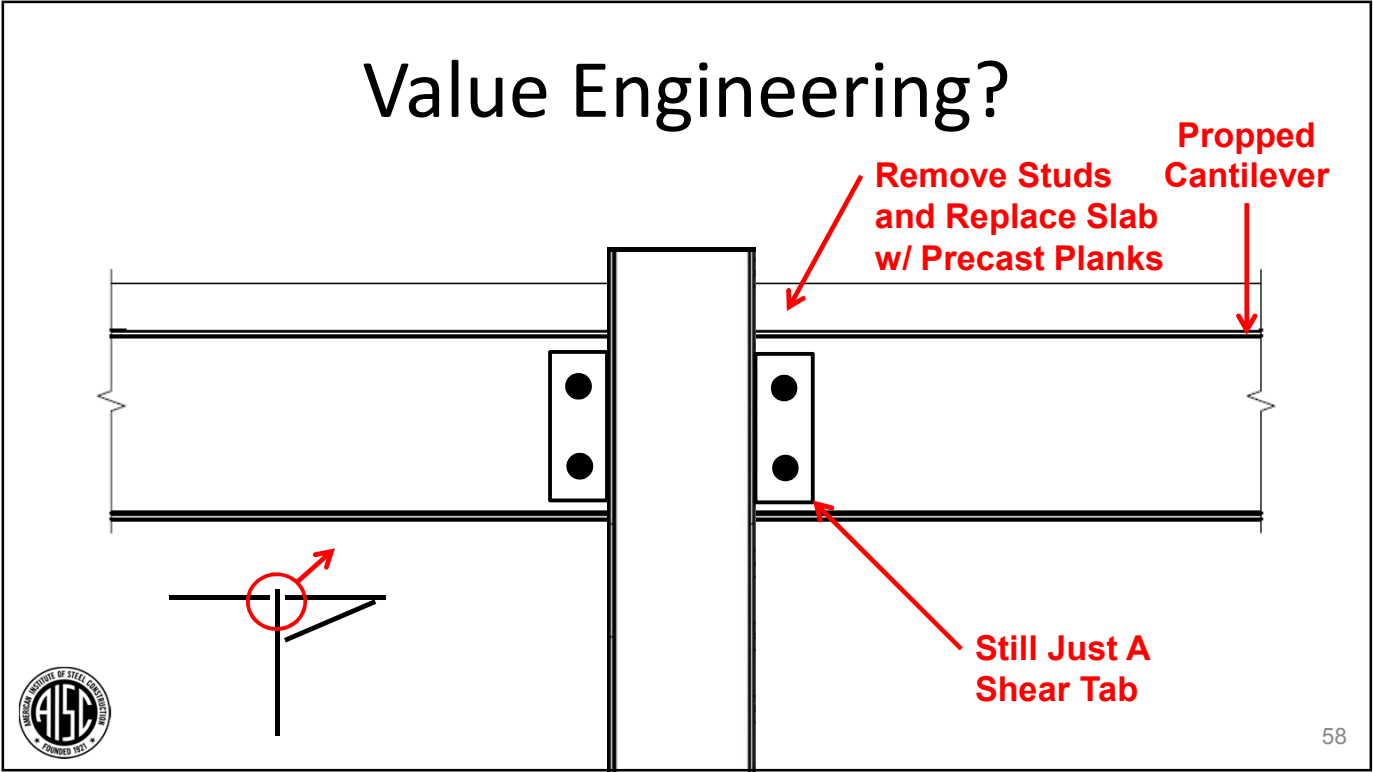
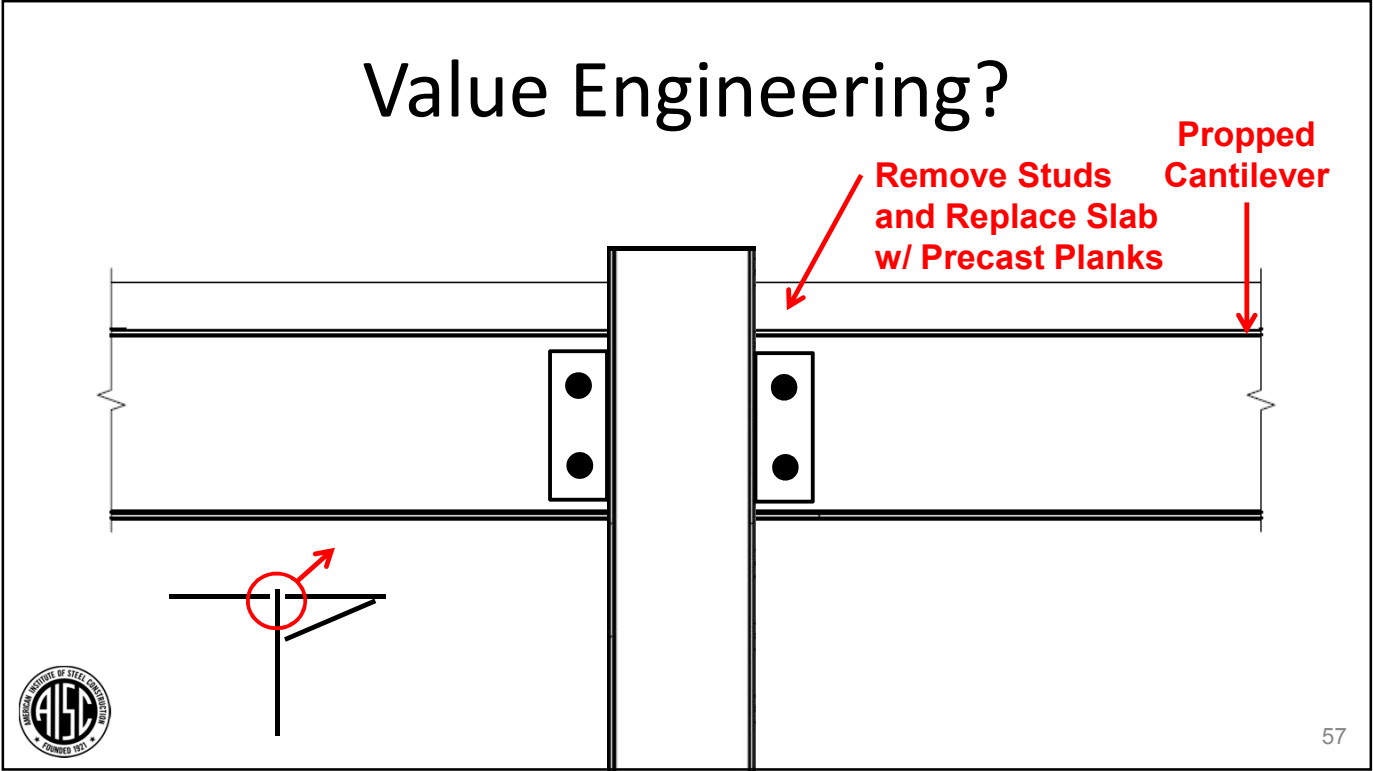

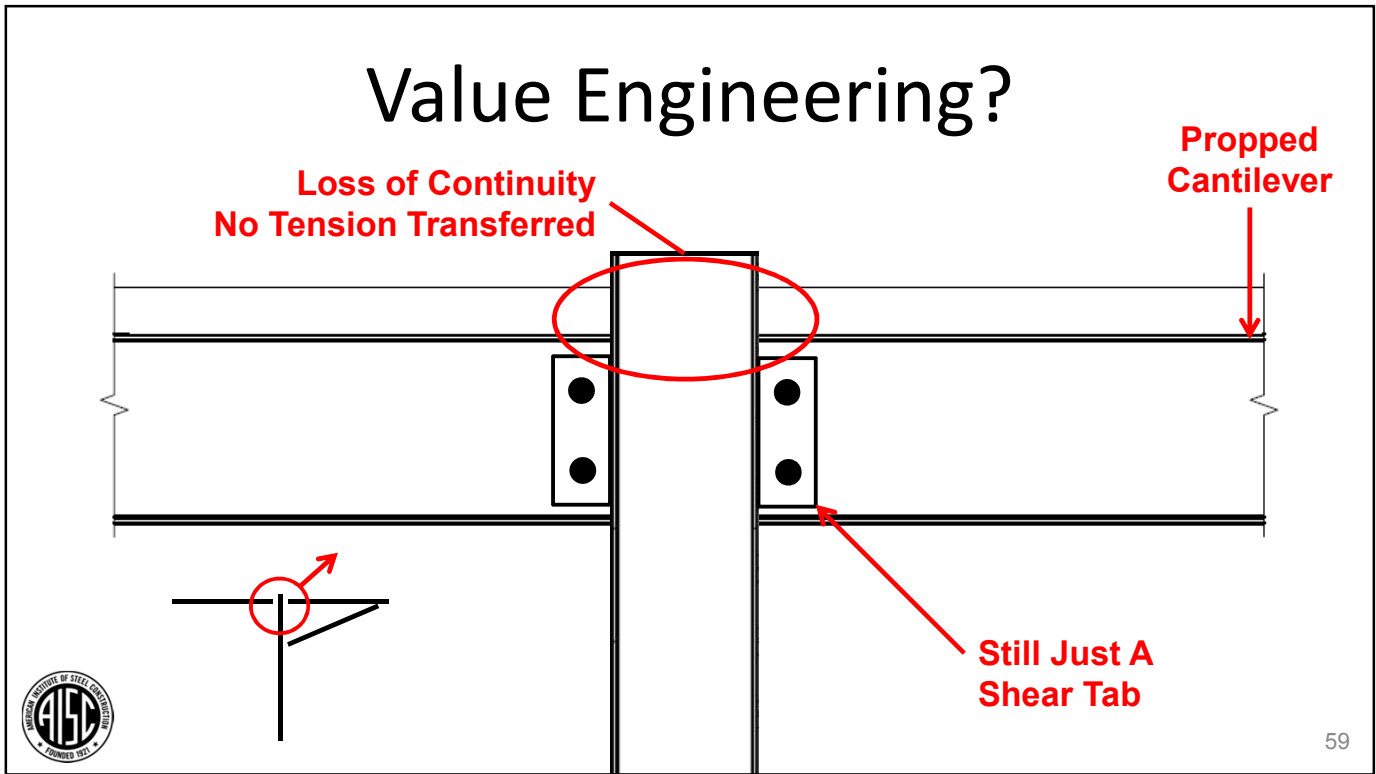

Let's Add Some REAL Value!!! 🤔

Fortunately a connection design engineer working for the fabricator noticed the loss of continuity and submitted an RFI...



60

Let's Add Some REAL Value!!!

Fortunately a connection design engineer working for the fabricator noticed the loss of continuity and submitted an RFI...

But the Engineer said there was no problem...



61

Let's Add Some REAL Value!!!

Fortunately a connection design engineer working for the fabricator noticed the loss of continuity and submitted an RFI...

But the Engineer said there was no problem...

So the Fabricator Tried Again...



62

Let's Add Some REAL Value!!!

Fortunately a connection design engineer working for the fabricator noticed the loss of continuity and submitted an RFI...

But the Engineer said there was no problem...

So the Fabricator Tried Again...And Again



63

Let's Add Some REAL Value!!!

Fortunately a connection design engineer working for the fabricator noticed the loss of continuity and submitted an RFI...

But the Engineer said there was no problem...

So the Fabricator Tried Again...And Again

...And Again...And Again... And Again...A



64

Let's Add Some REAL Value!!!



Finally the Fabricator had to issue a letter stating it was unsafe to continue erection.

This forced a face-to-face meeting with the Engineer of Record – who was unaware of the concerns his employee had dismissed.



65

The Show Must Go On

The issue was ultimately resolved and the project was completed on time.

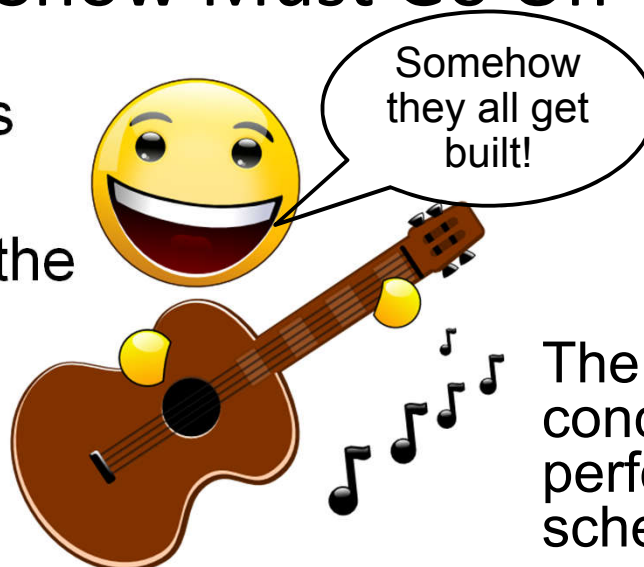

The first concert was performed as scheduled



66

3. Clear and Present Danger

Lessons Learned

- Carefully consider the possible unintended consequences of value engineering changes.
- Do not quickly dismiss the concerns of other project team members.
- Be willing to admit mistakes.



67

3. Clear and Present Danger

Poll Question



68

4. The Road Less Traveled



69

Just the Facts

- Meeting the *Seismic Provisions* increases the cost of projects.
- Fabricators should bid what they see. This is the position inherent in the COSP.
- When the scope of work changes from that established in the Contract Documents, a modification of the contract price shall be made. (paraphrased from the COSP)



70



The Reality

- Contract documents are often not clear or complete – especially at the bid-stage.
- Some bidding processes are not flexible enough to accommodate proper clarifications.



71

The Contractors' Dilemma

Bid what I see and
fight for extras
later.



Bid what I think the
engineer wants and
lose the project to a
lower bidder.



72

Some Project Specifics

- Large hospital
- Building codes in process of being updated – *Seismic Provisions* could either be incorporated or not
- Engineer expressed desire to incorporate latest and greatest provisions



73

The Road Less Traveled



74



The Road Less Traveled

- Fabricator provided preliminary costs – excluding extra seismic detailing.
- Fabricator was aware that including all the seismic detailing costs would inflate the bid relative to other less knowledgeable competitors.
- Extensive meetings were held to hammer out the differences between seismic and “non-seismic” bids.



75

The Road Less Traveled

- It may be better to walk away from a job than to accept an unfavorable or uncertain contract.
- However, there are other options. Bid clarifications and exceptions should not disqualify contractors. They should be taken as an indication that the contractor has thought through the project.



76

Final Result

- Owner, General Contractor and Engineer all understood what was and was not included in the bid.
- Fabricator was ultimately awarded the contract.
- An “ala carte” approach was taken with the seismic requirements.



77

4. The Road Less Traveled

Lessons Learned

- Fabricators and connection designers should not shy away from clarifying project requirements during the bid phase.
- When it would benefit the project, Engineers of Record should be flexible on project requirements.



78



5. Design Assist: When it Doesn't Work



79

Teamwork

Design Assist

When it Doesn't Work

80



Teamwork

Design Assist

- Not Really!

Short-listed fabricators meet with SEoR three times prior to award to discuss design assist issues

Several big ticket items are identified...

- High seismic systems in SDC B,
- SMF beam loads are UDL; connections will not satisfy AISC 358 requirements with this kind of loading
- Reinforcement requirements are inconsistent with limit state needs

81

Teamwork

Design Assist

- Not Really!

Several big ticket items are identified...

- Structural details are inconsistent with AISC 341,
 - "...it's not really seismic, we just used $R=8$ to reduce the base shear..."
- Design drawings have no indication of transfer forces in the braced frames
- No indication of collector beams or chords
- etc.

82



Teamwork

Design Assist

- Not Really!

Several big ticket items are identified...

- After award, IFCs do not address any of the issues identified pre-award
- After award, SEoR refuses to communicate with fabricator and connection designer
- ~90% of responses to CDQs are “...refer to the drawings...”
- Fabricator learns that one-sided connections are not permitted just toward the end of the shop drawing approval process

83

Teamwork

Design Assist

- Not Really!

Result...

- Multi-million dollar disputes
 - Resolution takes years
- Budget overrun
- Schedule overrun
- Mistrust that lasts a lifetime

84



5. Design Assist: When it Doesn't Work

Lessons Learned

- Verbal agreements need to be documented.
- A lack of respect and mistrust is detrimental to the success of a project.
- Incomplete or unclear requirements on design documents will lead to costly change orders.
- Bad experiences last forever and can damage future relationships.



85

5. Design Assist: When it Doesn't Work

Poll Question



86



6. EOR—Erector—Fabricator Cooperation



87

EOR, Erector, And Fabricator Cooperation



88



46 Story “Diagrid” Building

89



**A standardized
“node” was
used to connect
the diagrid
members and
form the
exoskeleton of
the building.**

90



This node was developed by the erector and the fabricator in cooperation with the EOR

91



The original node used splice plates perpendicular to those shown here.

92



The splice plates were originally connected to the brace flanges.

93



This connection change made erection a breeze. Imagine trying to erect this node with splice plates connecting to the flanges!

94

The node, as originally shown, would have made the diagrid members difficult if not impossible to erect.



95

The Diagrid Node

4" base plates

1 1/4" splice plates

10" X-plates



96





This building was
completed on
time and on
budget

97

6. EOR—Erector—Fabricator Cooperation

Lessons Learned

- Engaging the fabricator and erector during the design phase can greatly improve constructability.
- Collaboration between EOR, erector, and fabricator can provide economic benefits to the client.



98

7. How We Interact is Important



99

Respect and Trust

How we Interact is important



100



Respect and Trust

Billboard 100 exchanges

DCD: The drawings provide no loading information for connection design. For what loads do we design the connections?

SEoR: Whatever loads you think are reasonable!



101

Respect and Trust

Billboard 100 exchanges

Between two Delegated Designers...

DCD 1: I attended your presentation on effective communication.

DCD 2: What did you think?

DCD 1: Personally, I think if the SEoR delegates connection design they should just shut up and get out of my way.



102



Respect and Trust

Billboard 100 exchanges

DCD: Why are the moment connection designs rejected?

SEoR: You can't use story shear to reduce panel zone demands.

DCD: Why not?

SEoR: This building has no story shear.



103

Respect and Trust

Billboard 100 exchanges

DCD 1: If you want to understand the flow of forces through the connecting elements, you really have to draw a FBD.

DCD 2: Nah! I haven't drawn a FBD since my senior year of college.



104



Respect and Trust

Billboard 100 exchanges

DCD: So, these are three ideas for the field fix.

SEoR: Wait, do you have any options that don't use welds?

DCD: No! This condition is not conducive to bolted options.

SEoR: You are using welds to transfer loads, I don't like that; welds should be used to hold parts together, not transfer loads.



105

Respect and Trust

Billboard 100 exchanges

DCD 1: I spent about three weeks designing these moment connections.

DCD 2: I just make everything CJP to cut down on design time. The fabricator never question it (wry smile)!



106



Respect and Trust

Billboard 100 exchanges

My all time top favorite...

DCD: What you are suggesting violates the requirements of AISC 360.

SEoR: Well maybe when you grow up and become an engineer you will understand!



107

7. How We Interact is Important

Lessons Learned

- Perceived lack of interest is infectious.
- Blatant disrespect and an unwillingness to recognize others' value damages relationships as well as project success.
- The AISC COSP clearly identifies the SEoR as the final authority relative to connections.
- Free body diagrams are the "bee's knees".



108



8. Keep Your Eye on the Details

109

Keep Your Eye on the
Details

110





Ductile Seismic Design ?



111



Ductile Seismic Design ? These were called “barn door” gussets by the owner



112

Special Concentric Braced Frames Detailed for Inelastic Rotation

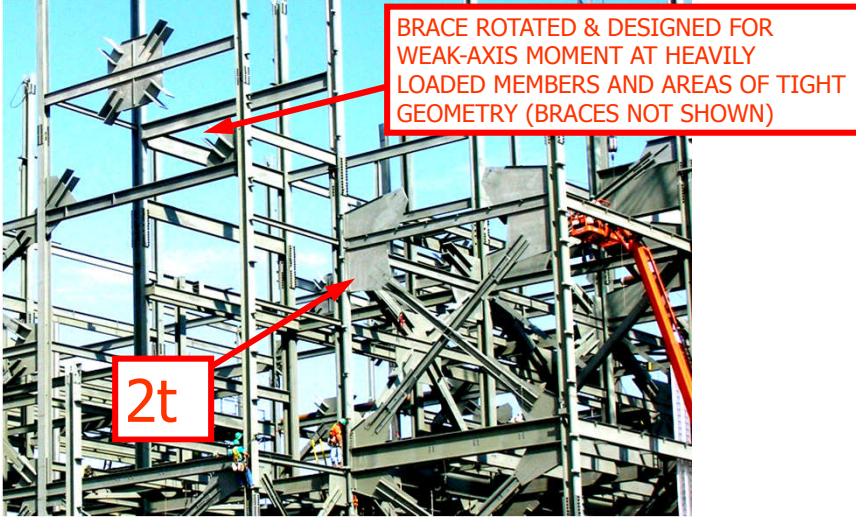

BRACE ROTATED & DESIGNED FOR WEAK-AXIS MOMENT AT HEAVILY LOADED MEMBERS AND AREAS OF TIGHT GEOMETRY (BRACES NOT SHOWN)

2t



113

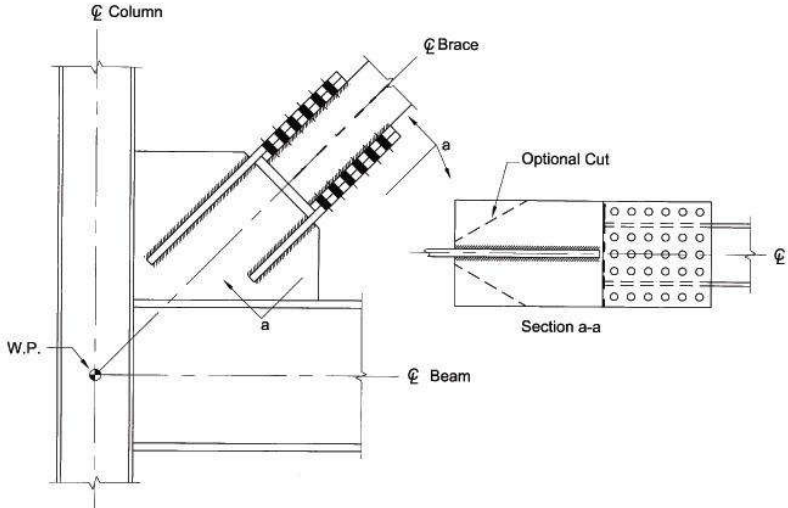

Wide Flange "Flange to View" Connection



114



Here is a better idea In-Plane Brace Buckling

From
 "Satisfying Inelastic Rotation Requirements For In-Plane Critical Axis Brace Buckling For High Seismic Design", W.A. Thornton and P.J. Fortney, AISC Engineering Journal, Third QTR.,2012, pp.99-108

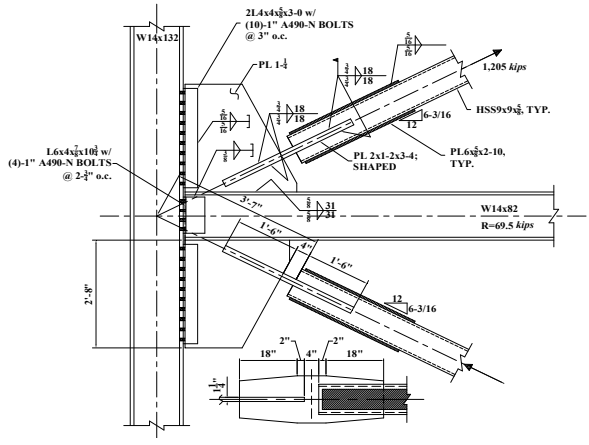

115

SCBF In-Plane Buckling

From
 "Satisfying Inelastic Rotation Requirements For In-Plane Critical Axis Brace Buckling For High Seismic Design", W.A. Thornton and P.J. Fortney, AISC Engineering Journal, Third QTR.,2012, pp. 99-108

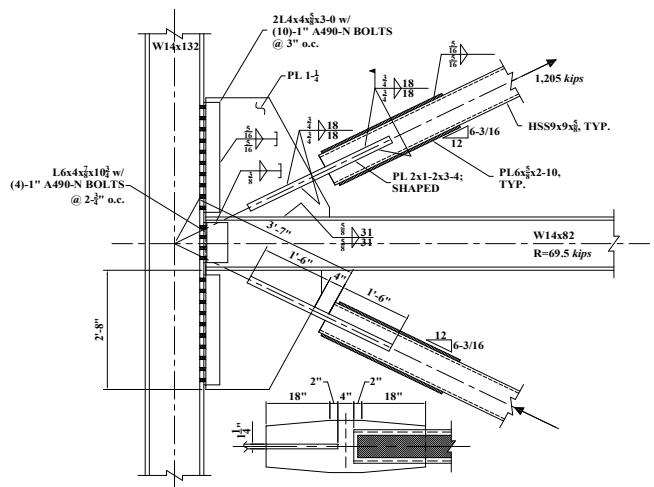

116



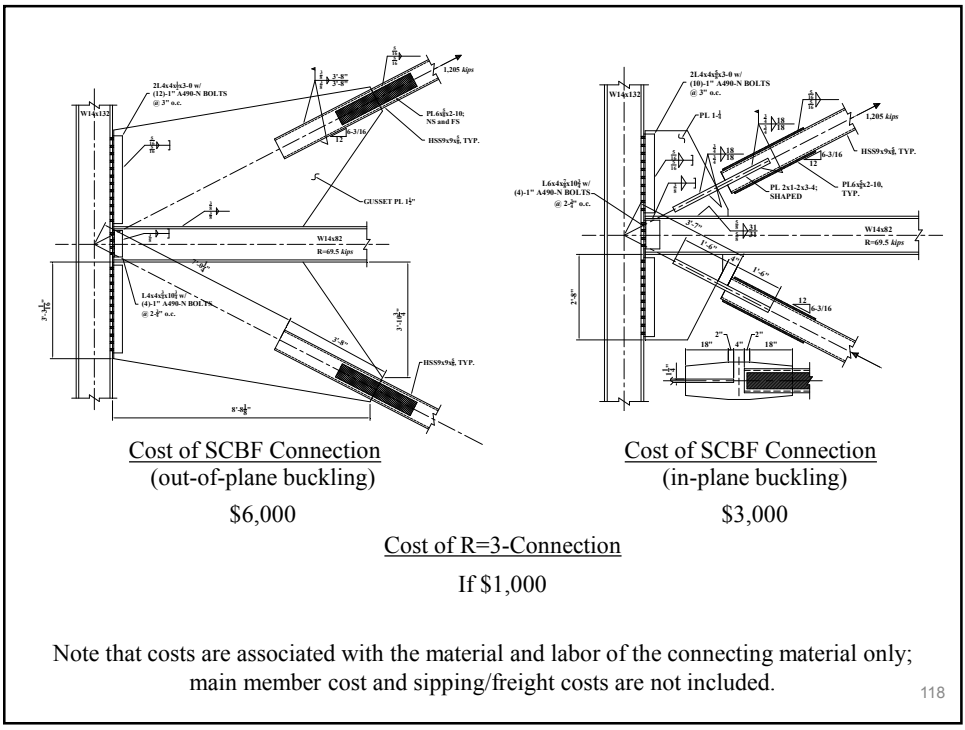
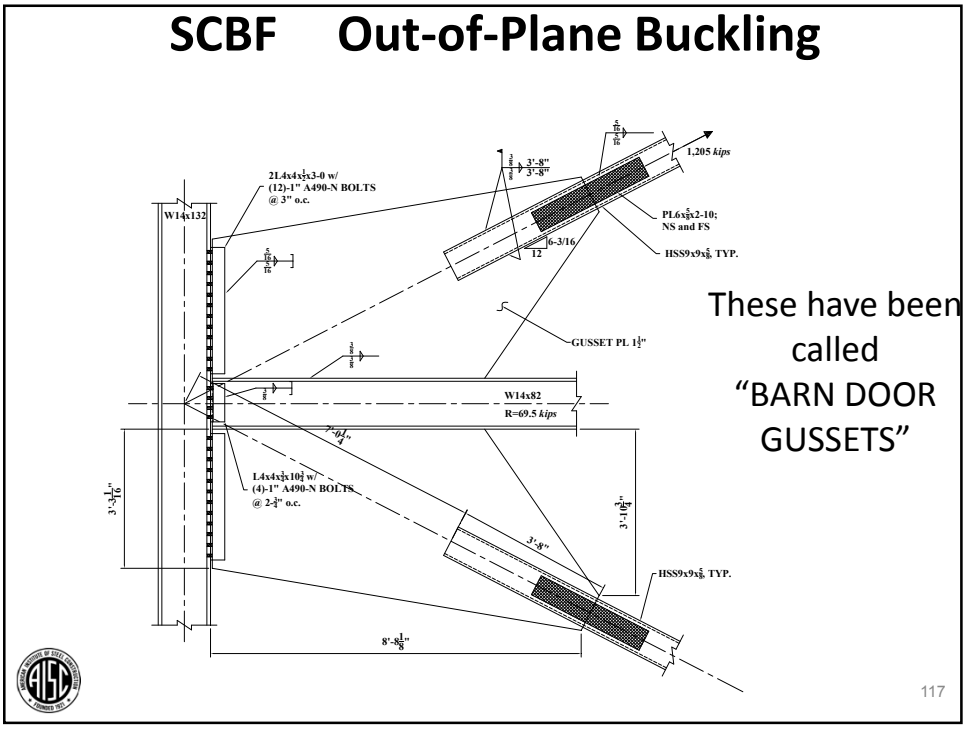

8. Keep Your Eye on the Details

Lessons Learned

- There are multiple details for achieving ductility in brace connections of special concentrically braced frames.
- Be open to alternative detailing solutions.
- Thoroughly detail your connections to-scale to assess practicality of the design.

119

AISC | Questions?



Individual Session Registrants

CEU / PDH Certificates

- You will receive an email on how to report attendance from:
registration@aisc.org.
- Be on the lookout: Check your spam filter! Check your junk folder!
- Completely fill out online form. Don't forget to check the boxes next to each attendee's name!



Individual Session Registrants

CEU / PDH Certificates

- Reporting site (URL will be provided in the forthcoming email).
- Username: Same as AISC website username.
- Password: Same as AISC website password.



8-Session Registrants

CEU / PDH Certificates

One certificate will be issued at the conclusion of all 8 sessions.



Smarter.
Stronger.
Steel.

8-Session Registrants

Access to the quiz

Information for accessing the quiz will be emailed to you by Wednesday. It will contain a link to access the quiz. EMAIL COMES FROM NIGHTSCHOOL@AISC.ORG.

Quiz and attendance records

Posted Tuesday mornings. www.aisc.org/nightschool -- Click on Current Course Details.

Reasons for quiz

- EEU – You must take all quizzes and the final exam to receive EEU.
- CEUs/PDHs – If you watch a recorded session, you must pass quiz for CEUs/PDHs.
- REINFORCEMENT – Reinforce what you learn tonight. Get more out of the course.

Note: If you attend the live presentation, you do not have to take the quizzes to receive CEUs/PDHs



Smarter.
Stronger.
Steel.

8-Session Registrants

Access to the recording

Information for accessing the recording will be emailed to you by Wednesday. The recording will be available for three weeks. (For 8-session registrants only.) EMAIL COMES FROM NIGHTSCHOOL@AISC.ORG.

CEUs / PDHs via recording

If you watch a recorded session, you must take *and pass* the quiz for CEUs/PDHs.



Smarter.
Stronger.
Steel.

8-Session Registrants

Night School Resources

Find all your handouts, quizzes and quiz scores, recording access, and attendance information all in one place!



Smarter.
Stronger.
Steel.

8-Session Registrants

Night School Resources

Go to www.aisc.org and sign in.



Login

If you're an existing customer, please enter your username and password.

USERNAME
Enter your username

PASSWORD
Enter your password

Remember Me

DON'T HAVE AN ACCOUNT?

My AISC allows you to access Engineering Journal articles and Design Guides you have downloaded from the bookstore.

[REGISTER NOW](#)



8-Session Registrants

Night School Resources

Go to www.aisc.org and sign in.

- IN THIS SECTION
- Edit Profile
- My Downloads
- My Pending Quizzes
- My Events
- Order History
- Course History
- Course Resources

MyAISC

MY PROFILE

Update your contact and address information.

[EDIT PROFILE](#)

MY PURCHASED DOWNLOADS

Access articles and documents that you have purchased.

[VIEW DOWNLOADS](#)

MY COURSE RESOURCES

View online resources for Night School and Live Webinar package registrations.

[VIEW RESOURCES](#)



8-Session Registrants

Night School Resources



Course Resources

Event	Start Date
NS 13 8-Session Package-Night School 13 - Design of Industrial Buildings	1/30/2017 7:00:00 PM
NS 14 8-Session Package-Night School 14 - Fundamentals of Stability	6/5/2017 7:00:00 PM



8-Session Registrants

Night School Resources



Night School 13: Design of Industrial Buildings

8-SESSION PACKAGE RESOURCES

Event	Date	Handouts	Video	Quiz	Attendance
NS13 - Design Criteria	1/30/2017 7:00:00 PM	Handouts	View Passcode: NS13DSN	Pass Score: 80	Pending
NS13 - Economic Considerations	2/6/2017 7:00:00 PM	Handouts	Available 02/08/2017 5pm EST	Available 02/08/2017 5pm EST	Pending
NS13 - Lateral Load Systems and Details	2/13/2017 7:00:00 PM	Handouts	Available 02/15/2017 5pm EST	Available 02/15/2017 5pm EST	Pending
NS13 - Preliminary Design Procedures	2/27/2017 7:00:00 PM	Handouts	Available 03/01/2017 5pm EST	Available 03/01/2017 5pm EST	Pending
NS13 - Crane Girder Design and Frame Analysis	3/6/2017 7:00:00 PM	Handouts	Available 03/08/2017 5pm EST	Available 03/08/2017 5pm EST	Pending
NS13 - Frame Member and Connection Design	3/13/2017 7:00:00 PM	Handouts	Available 03/15/2017 5pm EST	Available 03/15/2017 5pm EST	Pending
NS13 - Transfer Crane Girder & Longitudinal Bldg Bracing Dsn	3/27/2017 7:00:00 PM	Handouts	Available 03/29/2017 5pm EST	Available 03/29/2017 5pm EST	Pending
NS13 - Building Envelope and Bracing Design	4/3/2017 7:00:00 PM	Handouts	Available 04/05/2017 5pm EST	Available 04/05/2017 5pm EST	Pending



8-Session Registrants

Night School Resources

- Weekly “quiz and recording” email.
- Weekly updates of the master quiz and attendance record, found at www.aisc.org/nightschool19. Scroll down to Quiz and Attendance records.
 - Updated on Tuesday mornings.



8-Session Registrants

Night School Resources

- Webinar connection information
 - Found in your registration confirmation / receipt
 - Reminder email sent out Monday mornings
- Links to handouts also found here



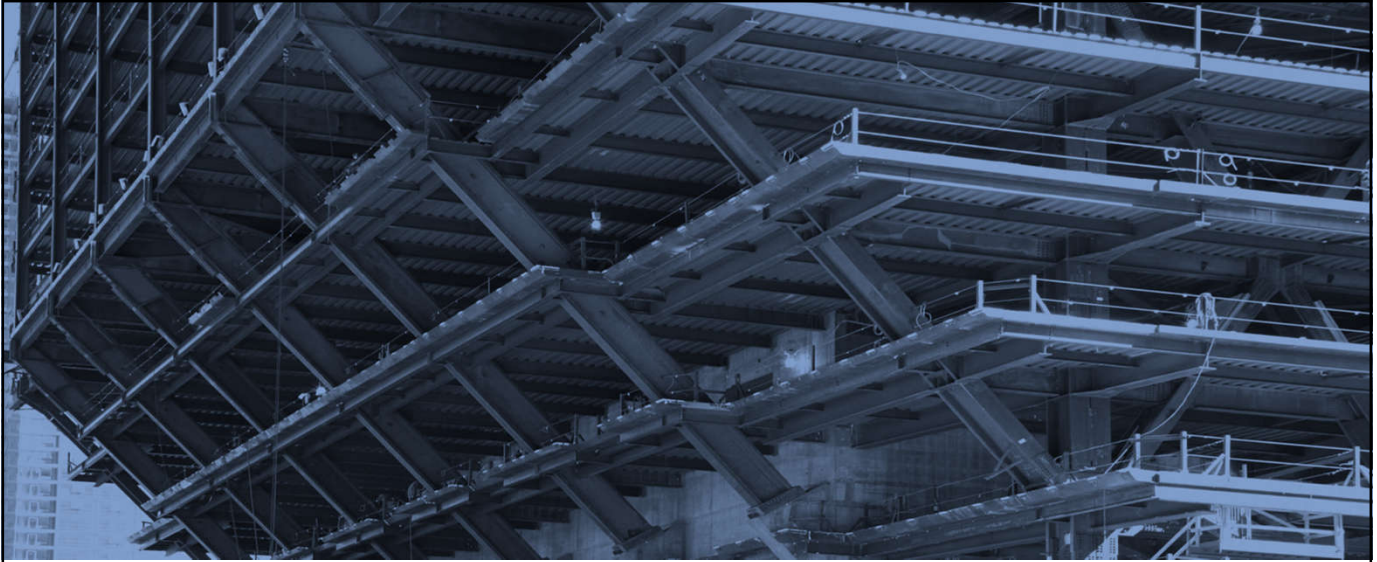

AISC | Thank you



Smarter.
Stronger.
Steel.

