



1. Which of the following are true regarding stability and determinacy?
 - a. A stable structure must be determinate.
 - b. An indeterminate structure must be stable.
 - c. Unstable structures may be stable for some loadings.
 - d. It is preferable that structures be stable and determinate.
 - e. None of these are true.

2. For superposition to be applicable:
 - a. Structures must behave elastically.
 - b. Equilibrium equations must be written about the deformed configuration.
 - c. The material must be steel.
 - d. a and b
 - e. None of these are true.

3. For the relationship between load, shear, and moment, which of the following is true?
 - a. The value of the shear is the slope of the loading diagram.
 - b. The slope of the moment diagram is the value of the shear.
 - c. The change in moment between A and B is the area under the load diagram between A and B.
 - d. The area under the moment diagram is the value of the shear.
 - e. The value of the load is the slope of the moment diagram.

4. How much work is done when you carry a 10 lb box 12 ft to the other side of the room?
 - a. 0 ft-lbs.
 - b. 10 ft-lbs.
 - c. 60 ft-lbs.
 - d. 120 ft-lbs.
 - e. None of these are correct.



5. The method of work (real work) can be used to determine the deflection:
- under the load for a beam loaded at the first $\frac{1}{4}$ point of the span.
 - at mid-span of a uniformly loaded beam.
 - at any node of a truss, regardless of loading pattern.
 - in the horizontal direction when a truss is loaded vertically.
 - None of these are correct.

Problem 6

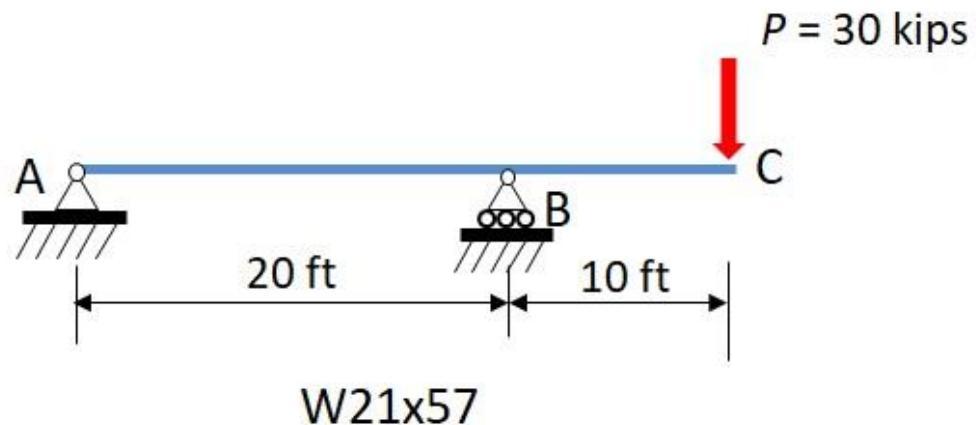

6. For the simple beam shown, by real work the deflection at C considering only flexure is approximately:
- 0.38 in.
 - 0.75 in.
 - 1.5 in.
 - 3.0 in.
 - None of the above
7. Expressions for virtual work do not include the $\frac{1}{2}$ factor that is included in the real work expressions. This is because:
- the virtual load does work by moving through the entire real deflection.
 - the area under the load displacement diagram for the virtual load is represented by a rectangle.
 - the real deflection is one half the virtual deflection.
 - a and b
 - None of these are true.



Problem 8

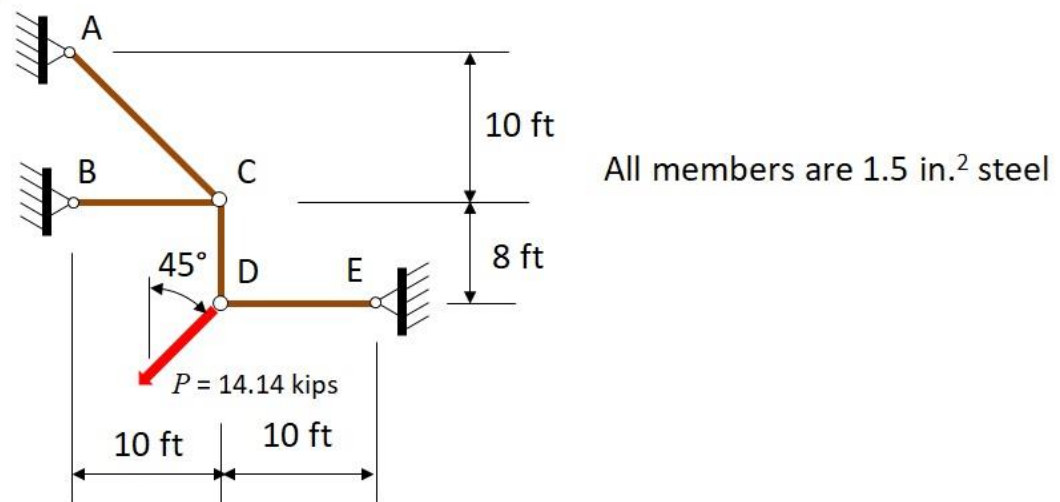

8. For the structure given, the vertical deflection at C by virtual work if all members have the same E and A is approximately:

- a. 0.105 in. down
- b. 0.105 in. up
- c. 0.053 in. up
- d. 0.053 in. down
- e. None of the above



Problem 9

Member	Length, L , (ft)	Area, A , (in. ²)
AB	25.0	1.0
BC	30.0	0.5
CD	25.0	0.5
AE	30.0	0.5
ED	30.0	0.5
BE	25.0	0.5
CE	25.0	0.5

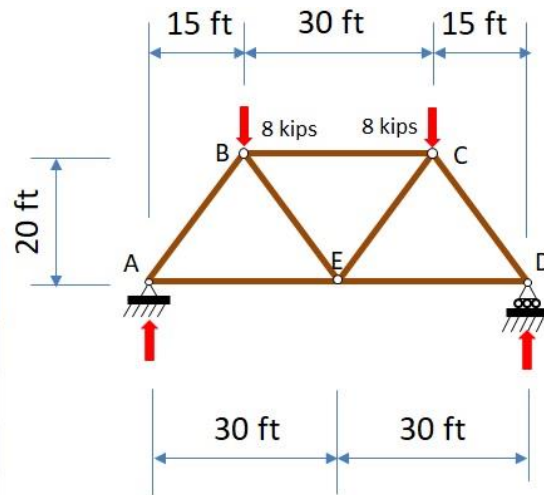

9. For the structure given, the horizontal deflection at point B is approximately:
- 0.223 in.
 - 0.267 in.
 - 0.446 in.
 - 0.533 in.
 - None of the above
10. Classical beam theory is not “exact” since several assumptions are made in its development. Which of the following assumptions are made in the development of classical beam theory?
- A plane before bending remains a plane during and after bending.
 - Rotations, θ , are sufficiently small such that $\text{SIN } \theta = \text{TAN } \theta = \theta$.
 - Slope on the deflected beam is large and cannot be ignored.
 - a and b
 - None of the above is true.



Problems 11 and 12

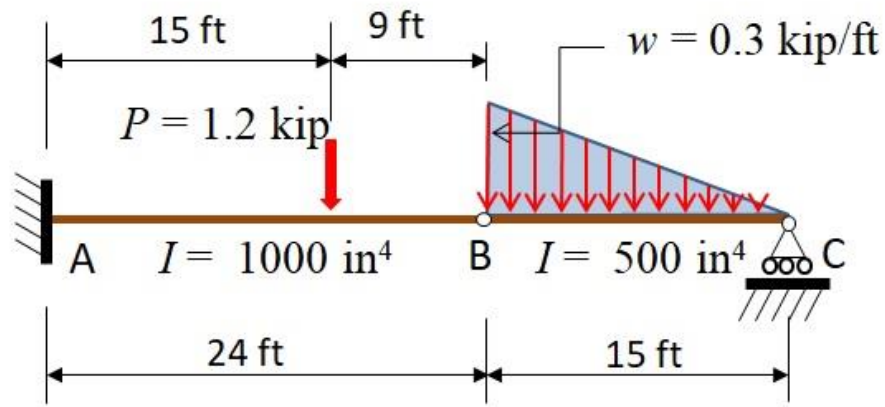

Material is steel

11. Using conjugate beam, the deflection at B is approximately:
- 0.15 in.
 - 0.41 in.
 - 0.56 in.
 - 0.73 in.
 - None of the above
12. For the beam of problem 11, the slope to the left of B is approximately:
- 0.00067 rad
 - 0.0021 rad
 - 0.0028 rad
 - 0.0034 rad
 - None are correct
13. When a structure is indeterminate it can be solved by the general method which involves which of the following?
- Removing all the reactions on the structure.
 - Determining the displacements that correspond to the removed redundants.
 - Calculating deflections due to unit loads.
 - a and b
 - b and c



Problem 14

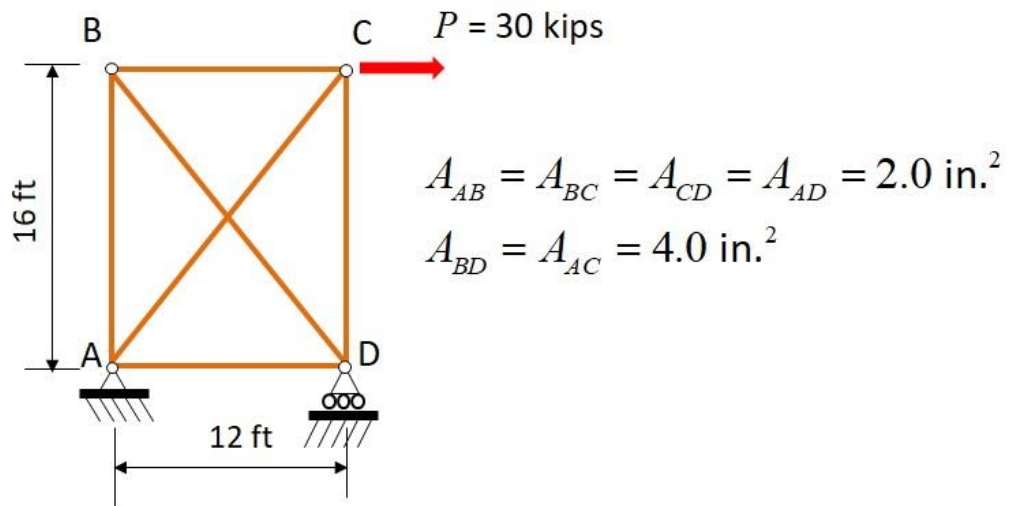

14. Using the general method, the force in member BD is approximately:

- a. 12.8 kips C
- b. 20.6 kips C
- c. 22.9 kips T
- d. 30.1 kips C
- e. None of these are correct.

Problem 15

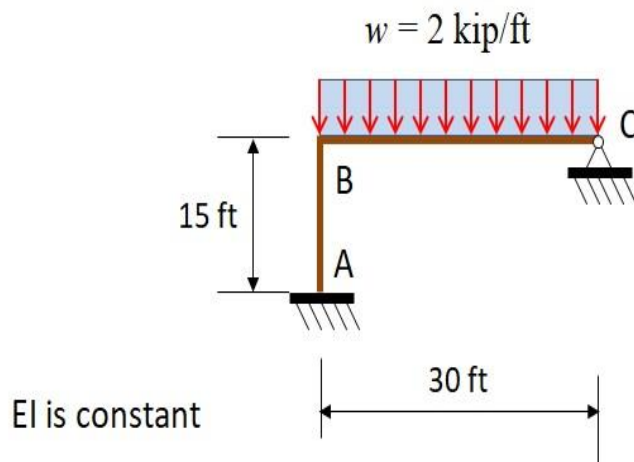

15. The given structure is 2 degrees indeterminate. The vertical reaction at C is approximately:

- a. 24.6 kips up
- b. 16.4 kips up
- c. 35.4 kips up
- d. 43.6 kips up
- e. None of the above



Problem 16

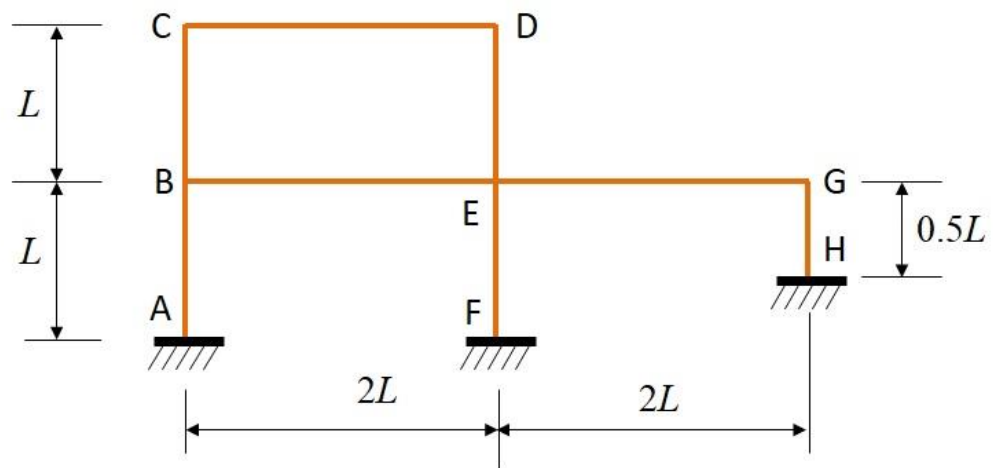

16. Using the slope deflection method, how many unknowns must be determined for the frame shown?

- a. 5
- b. 7
- c. 8
- d. 10
- e. None of these are correct.



Problem 17

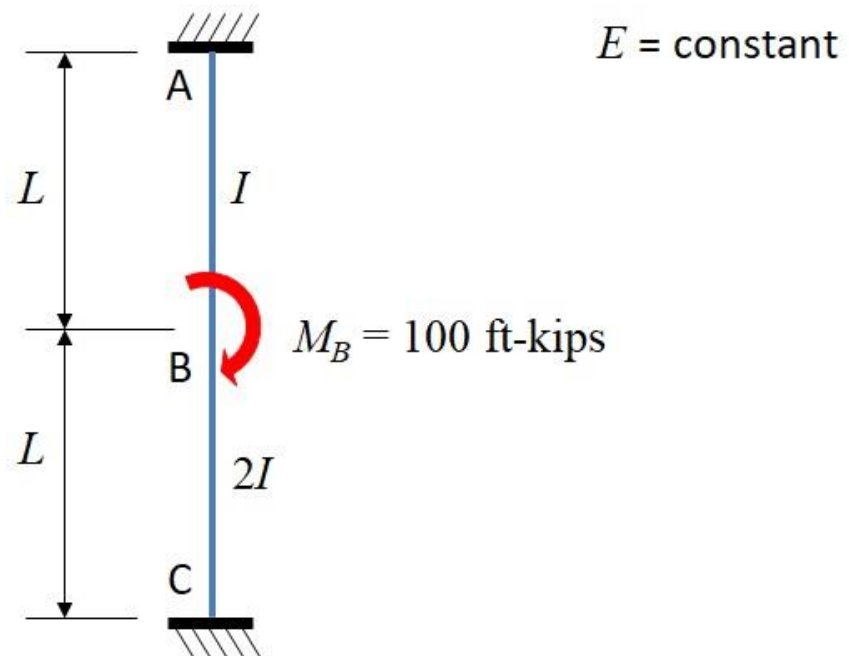

17. Using slope deflection, the moment M_{BC} is approximately:

- a. 18.2 ft-kips
- b. 50.0 ft-kips
- c. 54.5 ft-kips
- d. 45.5 ft-kips
- e. None of these are correct



Problem 18

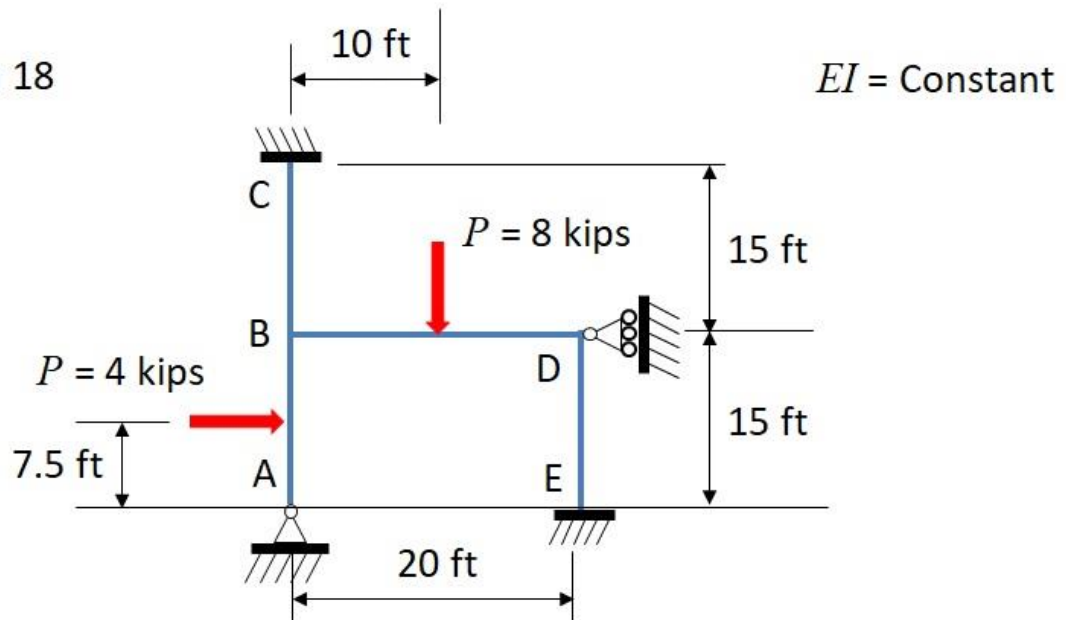

18. For the structure shown, determine by slope deflection the approximate moment M_{BA} .

- a. 75.0 ft-kips
- b. -14.9 ft-kips
- c. -2.44 ft-kips
- d. 15.3 ft-kips
- e. None of the above

19. Relative stiffness can often be used in moment distribution. Which of the following are true?

- a. Members cannot have different lengths.
- b. Relative stiffnesses can always be used.
- c. Members must have different stiffnesses
- d. a and b are true.
- e. None of these are true.



Problem 20

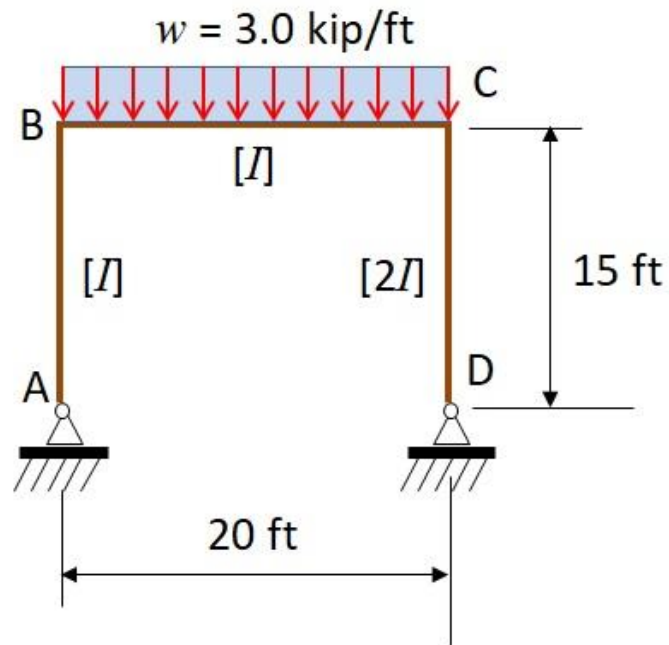

20. Using moment distribution for the structure shown, the artificial joint restraint is approximately:

- a. 1.80 kips
- b. 3.63 kips
- c. 5.43 kips
- d. 8.45 kips
- e. None of these are true



Classical Methods of Structural Analysis

Final Exam

Due: August 26, 8:00 a.m. EDT – Submit through the online form

Problem 21

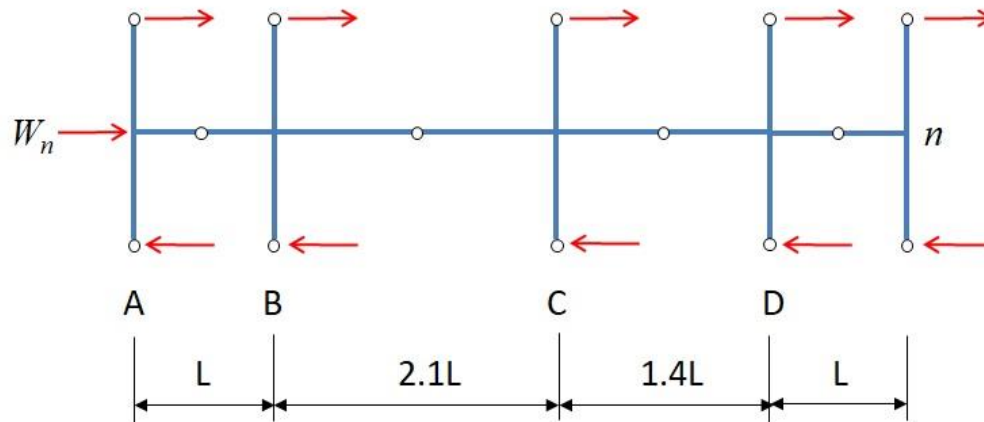

21. For the structure shown with different beam spans, determine the proportion of lateral load that should be assigned to the left exterior column according to the portal method.

- a. $1/11$
- b. $1/5.5$
- c. $2/5.5$
- d. $3/11$
- e. None of the above

22. Which of the following must be considered when doing an analysis according to AISC 360-16?

- a. All deformations
- b. Second-order effects
- c. Geometric imperfections
- d. All of the above
- e. None of the above

23. The approximate second-order analysis according to AISC 360-16 Appendix 8 requires:

- a. the use of moment distribution for the analysis.
- b. that structures be symmetrical.
- c. that all moments be amplified by a single amplification factor regardless of sway or non-sway.
- d. that analysis be done for the structure in a non-sway configuration.
- e. None of these above are true.



Copyright © 2019

American Institute of Steel Construction

Classical Methods of Structural Analysis

Final Exam

Due: August 26, 8:00 a.m. EDT – Submit through the online form

24. The advantage of the stiffness method over the slope deflection method is:
- a. that the computer can be used for solution.
 - b. that all deformations can be included as required by AISC 360-16.
 - c. that non-prismatic members can be considered.
 - d. All of the above
 - e. None of the above

