



Thank you for joining our live webinar today.

We will begin shortly.  
Please standby. Thank you.

Need Help?  
Call ReadyTalk Support:  
800.843.9166



**Welded Connections**  
A Primer for Engineers



**Smarter.  
Stronger.  
Steel.**



**Audio Options**

Today's audio will be broadcast through the internet.

Alternatively, to hear the audio through the phone, dial:

(866)-519-2796  
Passcode: 254072



**Smarter.  
Stronger.  
Steel.**



**Today's live webinar will begin shortly. Please stand by.**

As a reminder, all lines have been muted. Please type any questions or comments through the chat feature on the left portion of your screen.

Today's audio will be broadcast through the internet.  
Alternatively, to hear the audio through the phone, dial:

(866)-519-2796  
Passcode: 254072



**Smarter.  
Stronger.  
Steel.**



**AIA Credit**

AISC is a Registered Provider with The American Institute of Architects Continuing Education Systems (AIA/CES). Credit(s) earned on completion of this program will be reported to AIA/CES for AIA members. Certificates of Completion for both AIA members and non-AIA members are available upon request.

This program is registered with AIA/CES for continuing professional education. As such, it does not include content that may be deemed or construed to be an approval or endorsement by the AIA of any material of construction or any method or manner of handling, using, distributing, or dealing in any material or product.

Questions related to specific materials, methods, and services will be addressed at the conclusion of this presentation.



**Smarter.  
Stronger.  
Steel.**



### Copyright Materials

This presentation is protected by US and International Copyright laws. Reproduction, distribution, display and use of the presentation without written permission of AISC is prohibited.

© The American Institute of Steel Construction 2019

The information presented herein is based on recognized engineering principles and is for general information only. While it is believed to be accurate, this information should not be applied to any specific application without competent professional examination and verification by a licensed professional engineer. Anyone making use of this information assumes all liability arising from such use.



### Course Description

#### 21.8 Problems and Fixes December 10, 2019

This session covers problems associated with structural steel construction and provides solutions to many issues. Topics such as repairs to base metal, out-of-tolerance weld joints, repairs to welds, welding on anchor rods including extending rods that are too short, repairing lamellar tears and more are addressed in this session. In all cases, the session provides practical solutions to these common problems.



### Learning Objectives

- Describe all considerations for making repairs to base metal.
- List weldability concerns with extending anchor rods.
- Describe tolerance issues that may affect welded joints.
- Describe how to address a weld performed without proper inspection.



### Night School 21 Course Schedule

|            |                                     |
|------------|-------------------------------------|
| 10/8/2019  | 1. Introduction and Weld Processes  |
| 10/15/2019 | 2. Principles of Welded Connections |
| 10/29/2019 | 3. Welded Connection Details        |
| 11/5/2019  | 4. Metallurgy and Cracking          |
| 11/19/2019 | 5. Fatigue of Welded Connections    |
| 11/26/2019 | 6. Seismic Welding Issues           |
| 12/3/2019  | 7. Special Welding Applications     |
| 12/10/2019 | 8. Problems and Fixes               |



# Night School 21 Welded Connections -- A Primer for Engineers

Session 8: Problems and Fixes  
December 10, 2019



Duane K. Miller, PE, ScD  
Manager of Engineering Services and Welding  
Design Consultant



## PROBLEMS AND FIXES



10

### AISC Design Guide 21, 2<sup>nd</sup> Edition

Welded Connections – A Primer for  
Engineers

### Chapter 15: Problems and Fixes

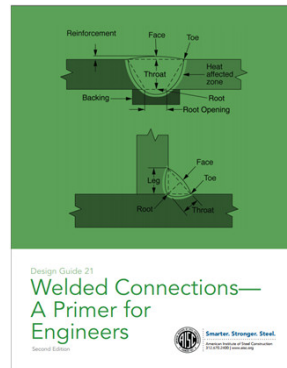

11

### AWS D1.1

Structural Welding Code – Steel

“...with the approval of the Engineer...”

“...when approved by the Engineer...”

“...Engineer approval shall be required...”

“...discretion of the Engineer...”

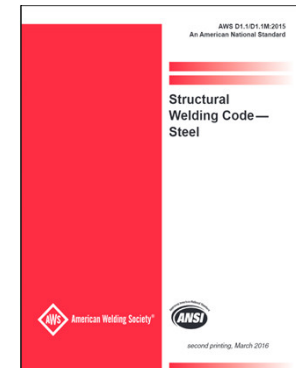

**AWS D1.1:2015 Structural Welding Code--Steel**

**5.25.3 Engineer's Approval.**  
**Prior approval of the Engineer** shall be obtained for repairs to base metal (other than those required by 5.14), repair of major or delayed cracks, repairs to ESW and EGW with internal defects, or for a revised design to compensate for deficiencies. The Engineer shall be notified before welded members are cut apart.



13

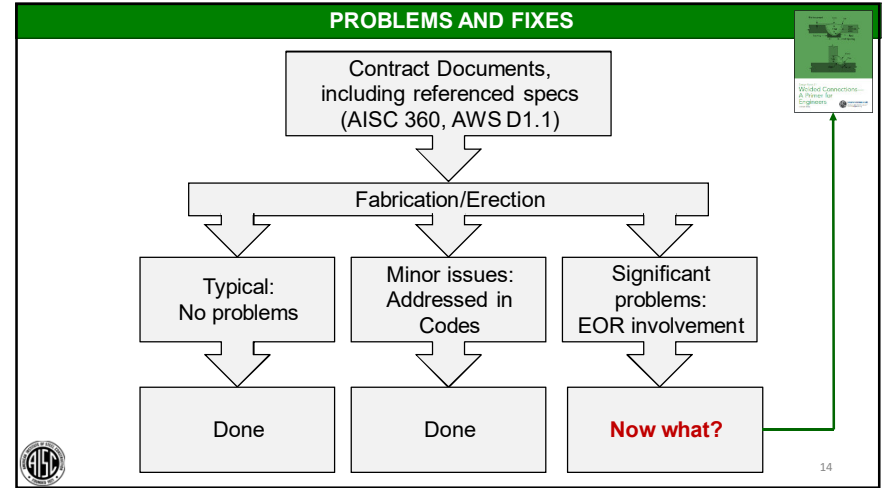

**AISC Design Guide 21, 2<sup>nd</sup> Edition**

Welded Connections – A Primer for Engineers

**Chapter 15: Problems and Fixes**



15

**PROBLEMS AND FIXES**

**Chapter 15: Problems and Fixes**

- 15.1 Repairs to Base Metal
- 15.2 Repairs to Cut Edges
- 15.3 Butt Joint Alignment
- 15.4 Out-of-Tolerance Weld Joints
- 15.5 Fixing Members that are Cut Short
- 15.6 Repair of Mislocated Holes
- 15.7 Use of Plug Welds in Lieu of Bolts
- 15.8 Repairs to Welds



16

**PROBLEMS AND FIXES**

**Chapter 15: Problems and Fixes**

- 15.9 Heat Shrinking of Q&T Steel
- 15.10 Unspecified Welds
- 15.11 Welds Made Without Inspection
- 15.12 Welding on Anchor Rods
- 15.13 Welding Anchor Rod-to-Base Plates
- 15.14 Removing and Reinstalling Column Base Plates
- 15.15 Repairing Lamellar Tears



17

**PROBLEMS AND FIXES**

**Chapter 15: Problems and Fixes**

- ➔ 15.1 Repairs to Base Metal
- 15.2 Repairs to Cut Edges
- 15.3 Butt Joint Alignment
- 15.4 Out-of-Tolerance Weld Joints
- 15.5 Fixing Members that are Cut Short
- 15.6 Repair of Mislocated Holes
- 15.7 Use of Plug Welds in Lieu of Bolts
- 15.8 Repairs to Welds



18

**AWS D1.1:2015 Structural Welding Code--Steel**

**5.25.3 Engineer's Approval.**

Prior approval of the Engineer shall be obtained for repairs to base metal (other than those required by 5.14), repair of major or delayed cracks, repairs to ESW and EGW with internal defects, or for a revised design to compensate for deficiencies. The Engineer shall be notified before welded members are cut apart.



19

**PROBLEMS AND FIXES**

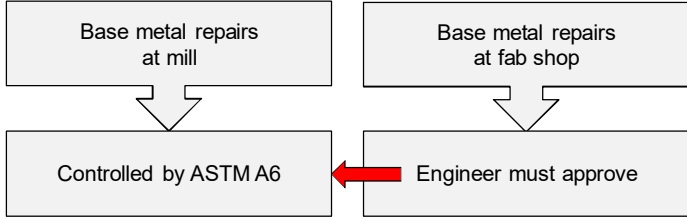

```
graph TD; A[Base metal repairs at mill] --> C[Controlled by ASTM A6]; B[Base metal repairs at fab shop] --> C; D[Engineer must approve] --> C;
```



20

**PROBLEMS AND FIXES**

**15.1.2 Repair of Mill-Induced Discontinuities**

**Table 15-1. Limits on Imperfection Repaired by Grinding**

| Material Thickness, in. (mm) | Maximum Removal Depth, in. (mm) |
|------------------------------|---------------------------------|
| < 3/8 (10)                   | 1/32 (1)                        |
| 3/8 (10) – 2 (50)            | 1/16 (2)                        |
| > 2 (50)                     | 1/8 (3)                         |

*This table was adapted from ASTM A6, Section 9.2.*



21

**PROBLEMS AND FIXES**

**15.1.2 Repair of Mill-Induced Discontinuities**

**Table 15-1. Limits on Imperfection Repaired by Grinding**

| Material Thickness, in. (mm) | Maximum Removal Depth, in. (mm) |
|------------------------------|---------------------------------|
| < 3/8 (10)                   | 1/32 (1)                        |
| 3/8 (10) – 2 (50)            | 1/16 (2)                        |
| > 2 (50)                     | 1/8 (3)                         |

*This table was adapted from ASTM A6, Section 9.2.*



22



**ASTM A6 (summary)**

- The total area of ground material must not exceed 2% of the total surface area of that piece.
- The reduction in thickness by grinding must not exceed 30% of the nominal thickness of the material at the location of the imperfection, nor exceed 1-1/4 in. (31 mm).
- For defects that require deeper removal depths than those shown in Table 15-1, repair by welding is permitted.

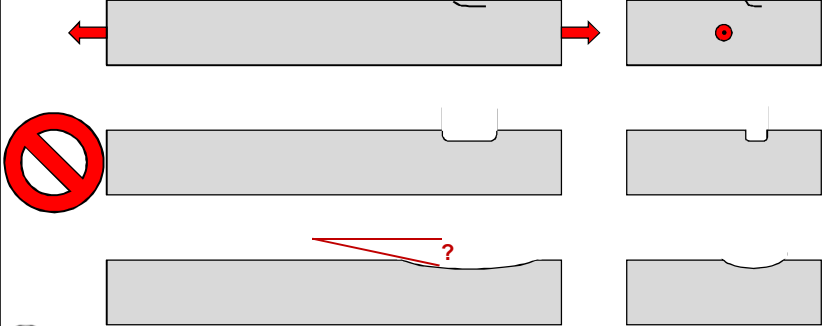

23

**PROBLEMS AND FIXES**

24

AWS D1.8/D1.8M:2016

**Structural Welding Code—  
Seismic Welding Supplement**



25

**AWS D1.8:2016 Seismic Welding Supplement**

**6.18.5 Repair of Gouges and Notches.**

Gouges and notches in the **Protected Zone** shall be repaired as follows:

**6.18.5.1 Grinding.**

When gouges and notches are repaired by grinding, the ground area shall provide a gradual taper to the surface of the base metal. **In the direction parallel to the member axis, the taper shall not be greater than 1:5. In the direction transverse to the member axis, the taper shall not be greater than 1:2.5.**



26

**PROBLEMS AND FIXES**

**Repairs to Base Metal: Summary**

- EOR involvement needed for repairs made in the base metal in the shop, but not in the mill
- DG21 recommendation: apply ASTM A6 criteria to shop repairs
- DG21 recommendation: for slope: D1.8 provides a conservative criteria
- For welded repairs, location of repair should be considered



27

**PROBLEMS AND FIXES**

**Chapter 15: Problems and Fixes**

- 15.1 Repairs to Base Metal
- ➔ 15.2 Repairs to Cut Edges
- 15.3 Butt Joint Alignment
- 15.4 Out-of-Tolerance Weld Joints
- 15.5 Fixing Members that are Cut Short
- 15.6 Repair of Mislocated Holes
- 15.7 Use of Plug Welds in Lieu of Bolts
- 15.8 Repairs to Welds





28

**PROBLEMS AND FIXES**

**15.2 Repairs to Cut Edges**

- Repairs to mill-induced discontinuities
- Repairs to contractor-induced discontinuities





29

**AWS D1.1:2015 Structural Welding Code--Steel**

**5.25.3 Engineer's Approval.**

Prior approval of the Engineer shall be obtained for repairs to base metal (other than those required by 5.14), repair of major or delayed cracks, repairs to ESW and EGW with internal defects, or for a revised design to compensate for deficiencies. The Engineer shall be notified before welded members are cut apart.





30

**AWS D1.1:2015 Structural Welding Code--Steel**

**5.14.5 Mill-Induced Discontinuities.**



The limits of acceptability and the repair of visually observed cut surface discontinuities shall be in conformance with Table 5.4 in which the length of discontinuity is the visible long dimension on the cut surface of material and the depth is the distance that the discontinuity extends into the material from the cut surface. All welded repairs shall be in conformance with this code. Removal of the discontinuity may be done from either surface of the base metal. The aggregate length of welding shall not exceed 20% of the length of the plate surface being repaired except with approval of the Engineer.



31

**AWS D1.1:2015 Structural Welding Code--Steel**

(4) If the area of the discontinuity W, X, Y, or Z exceeds the allowable in 5.14.5.1(2), the cut material or subcomponent shall be rejected and replaced, or repaired at the discretion of the Engineer.



32

**AWS D1.1:2015 Structural Welding Code--Steel**

Figure 5.1—Edge Discontinuities in Cut Material

33

**PROBLEMS AND FIXES**

34

**PROBLEMS AND FIXES**

**Limits on Acceptability and Repair of Mill Induced Laminar Discontinuities in Cut Surfaces**

| Discontinuity  |                 | Repair                     |
|----------------|-----------------|----------------------------|
| Length (L)     | Depth           |                            |
| ≤ 1 in [25 mm] | any             | None, need not be explored |
| > 1 in [25 mm] | ≤ 1/8 in [3 mm] | None, but determine depth  |
|                | > 1/8 in [3mm]  | Remove, need not weld      |
|                | ≤ 1/4 in [6 mm] |                            |
|                | >1/4 in [6 mm]  | Remove and weld            |
|                | ≤ 1 in [25 mm]  |                            |
| >1 in [25 mm]  | See 5.14.5.1    |                            |

Adapted from AWS D1.1, Table 5.4.

35

**PROBLEMS AND FIXES**

**Limits on Acceptability and Repair of Mill Induced Laminar Discontinuities in Cut Surfaces**

| Discontinuity  |                 | Repair                     |
|----------------|-----------------|----------------------------|
| Length (L)     | Depth           |                            |
| ≤ 1 in [25 mm] | any             | None, need not be explored |
| > 1 in [25 mm] | ≤ 1/8 in [3 mm] | None, but determine depth  |
|                | > 1/8 in [3mm]  | Remove, need not weld      |
|                | ≤ 1/4 in [6 mm] |                            |
|                | >1/4 in [6 mm]  | Remove and weld            |
|                | ≤ 1 in [25 mm]  |                            |
| >1 in [25 mm]  | See 5.14.5.1    |                            |

Adapted from AWS D1.1, Table 5.4.

36

**PROBLEMS AND FIXES**

All are acceptable if the visible dimension is  $\leq 1$  in. [25 mm].

Welded Connections – A Primer for Engineers

37

**PROBLEMS AND FIXES**

**Limits on Acceptability and Repair of Mill Induced Laminar Discontinuities in Cut Surfaces**

| Discontinuity       |                      | Repair                     |
|---------------------|----------------------|----------------------------|
| Length (L)          | Depth                |                            |
| $\leq 1$ in [25 mm] | any                  | None, need not be explored |
| $> 1$ in [25 mm]    | $\leq 1/8$ in [3 mm] | None, but determine depth  |
|                     | $> 1/8$ in [3mm]     | Remove, need not weld      |
|                     | $\leq 1/4$ in [6 mm] |                            |
|                     | $> 1/4$ in [6 mm]    | Remove and weld            |
|                     | $\leq 1$ in [25 mm]  |                            |
| $> 1$ in [25 mm]    | See 5.14.5.1         |                            |

Adapted from AWS D1.1, Table 5.4.

Welded Connections – A Primer for Engineers

38

**PROBLEMS AND FIXES**

**Limits on Acceptability and Repair of Mill Induced Laminar Discontinuities in Cut Surfaces**

| Discontinuity       |                      | Repair                     |
|---------------------|----------------------|----------------------------|
| Length (L)          | Depth                |                            |
| $\leq 1$ in [25 mm] | any                  | None, need not be explored |
| $> 1$ in [25 mm]    | $\leq 1/8$ in [3 mm] | None, but determine depth  |
|                     | $> 1/8$ in [3mm]     | Remove, need not weld      |
|                     | $\leq 1/4$ in [6 mm] |                            |
|                     | $> 1/4$ in [6 mm]    | Remove and weld            |
|                     | $\leq 1$ in [25 mm]  |                            |
| $> 1$ in [25 mm]    | See 5.14.5.1         |                            |

Adapted from AWS D1.1, Table 5.4.

Welded Connections – A Primer for Engineers

39

**PROBLEMS AND FIXES**

**Limits on Acceptability and Repair of Mill Induced Laminar Discontinuities in Cut Surfaces**

| Discontinuity       |                      | Repair                     |
|---------------------|----------------------|----------------------------|
| Length (L)          | Depth                |                            |
| $\leq 1$ in [25 mm] | any                  | None, need not be explored |
| $> 1$ in [25 mm]    | $\leq 1/8$ in [3 mm] | None, but determine depth  |
|                     | $> 1/8$ in [3mm]     | Remove, need not weld      |
|                     | $\leq 1/4$ in [6 mm] |                            |
|                     | $> 1/4$ in [6 mm]    | Remove and weld            |
|                     | $\leq 1$ in [25 mm]  |                            |
| $> 1$ in [25 mm]    | See 5.14.5.1         |                            |

Adapted from AWS D1.1, Table 5.4.

Welded Connections – A Primer for Engineers

40

**AWS D1.1:2015 Structural Welding Code--Steel**

**Note to AWS D1.1 Table 5.4:**

A spot check of 10% of the discontinuities on the cut surface in question should be explored by grinding to determine depth. If the depth of any one of the discontinuities explored exceeds 1/8 in [3 mm], then all of the discontinuities over 1 in [25 mm] in length remaining on that cut surface shall be explored by grinding to determine depth. If none of the discontinuities explored in the 10% spot check have a depth exceeding 1/8 in [3 mm], then the remainder of the discontinuities on that cut surface need not be explored.



41

**PROBLEMS AND FIXES**

These are acceptable if the visible dimension is > 1 in. [25 mm], and depth is less than 1/8 in. [3 mm].

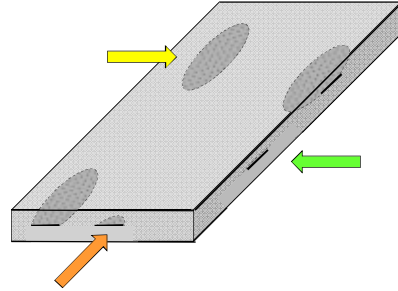

42

**PROBLEMS AND FIXES**

These are acceptable if the visible dimension is > 1 in. [25 mm], and depth is less than 1/8 in. [3 mm] if not found in the 10% check.

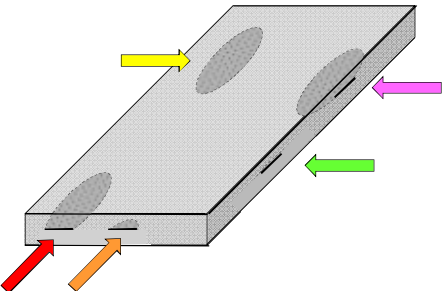

43

**PROBLEMS AND FIXES**

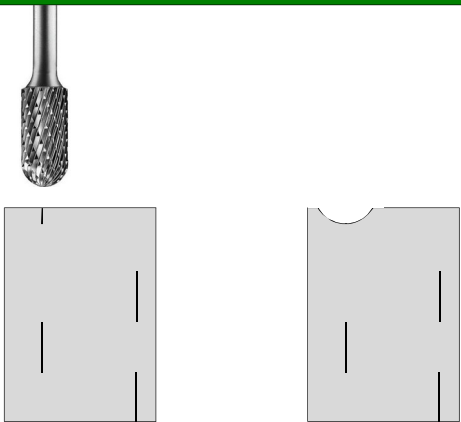

44

**PROBLEMS AND FIXES**

Welded Connections – A Primer for Engineers

45

**PROBLEMS AND FIXES**

**Limits on Acceptability and Repair of Mill Induced Laminar Discontinuities in Cut Surfaces**

| Discontinuity       |                      | Repair                     |
|---------------------|----------------------|----------------------------|
| Length (L)          | Depth                |                            |
| $\leq 1$ in [25 mm] | any                  | None, need not be explored |
| $> 1$ in [25 mm]    | $\leq 1/8$ in [3 mm] | None, but determine depth  |
|                     | $> 1/8$ in [3mm]     | Remove, need not weld      |
|                     | $\leq 1/4$ in [6 mm] |                            |
|                     | $> 1/4$ in [6 mm]    | Remove and weld            |
|                     | $\leq 1$ in [25 mm]  | See 5.14.5.1               |
| $> 1$ in [25 mm]    |                      |                            |

Adapted from AWS D1.1, Table 5.4.

Welded Connections – A Primer for Engineers

46

**PROBLEMS AND FIXES**

Shallow grinding of a small inclusion may reveal another inclusion, and then another.

Welded Connections – A Primer for Engineers

47

**PROBLEMS AND FIXES**

**Limits on Acceptability and Repair of Mill Induced Laminar Discontinuities in Cut Surfaces**

| Discontinuity       |                      | Repair                     |
|---------------------|----------------------|----------------------------|
| Length (L)          | Depth                |                            |
| $\leq 1$ in [25 mm] | any                  | None, need not be explored |
| $> 1$ in [25 mm]    | $\leq 1/8$ in [3 mm] | None, but determine depth  |
|                     | $> 1/8$ in [3mm]     | Remove, need not weld      |
|                     | $\leq 1/4$ in [6 mm] |                            |
|                     | $> 1/4$ in [6 mm]    | Remove and weld            |
|                     | $\leq 1$ in [25 mm]  | See 5.14.5.1               |
| $> 1$ in [25 mm]    |                      |                            |

Adapted from AWS D1.1, Table 5.4.

Welded Connections – A Primer for Engineers

48

| PROBLEMS AND FIXES   |                 |                            |
|--|-----------------|----------------------------|
| Limits on Acceptability and Repair of Mill Induced Laminar Discontinuities in Cut Surfaces |                 |                            |
| Discontinuity  |                 | Repair                     |
| Length (L)   | Depth           |                            |
| ≤ 1 in [25 mm]   | any             | None, need not be explored |
| > 1 in [25 mm]   | ≤ 1/8 in [3 mm] | None, but determine depth  |
|  | > 1/8 in [3mm]  | Remove, need not weld      |
|  | ≤ 1/4 in [6 mm] |                            |
|  | > 1/4 in [6 mm] | Remove and weld            |
|  | ≤ 1 in [25 mm]  |                            |
| > 1 in [25 mm]   | See 5.14.5.1    |                            |

Adapted from AWS D1.1, Table 5.4.

**AWS D1.1:2015 Structural Welding Code--Steel**

**5.14.5.1 Acceptance Criteria.**  
For discontinuities greater than 1 in [25 mm] in length and depth discovered on cut surfaces, the following procedures shall be observed.  
(1) Where discontinuities such as W, X, or Y in Figure 5.1 are observed prior to completing the joint, the size and shape of the discontinuity shall be **determined by UT.** ...

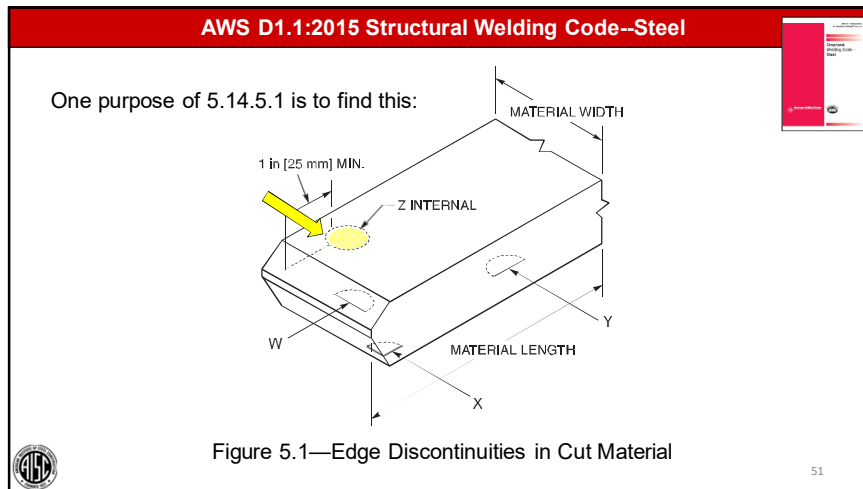

**AWS D1.1:2015 Structural Welding Code--Steel**

(4) If the area of the discontinuity W, X, Y, or Z exceeds the allowable in 5.14.5.1(2), the cut material or subcomponent shall be rejected and replaced, or repaired **at the discretion of the Engineer.**

**AWS D1.1:2015 Structural Welding Code--Steel**

**5.14.5.2 Repair.**

In the repair and determination of limits of mill induced discontinuities visually observed on cut surfaces, the amount of metal removed shall be the minimum necessary to remove the discontinuity or to determine the limits of Table 5.4 are not exceeded. ...

**NOTE: The requirements of 5.14.5.2 may not be adequate in cases of tensile load applied through the thickness of the material.**



53

**PROBLEMS AND FIXES**

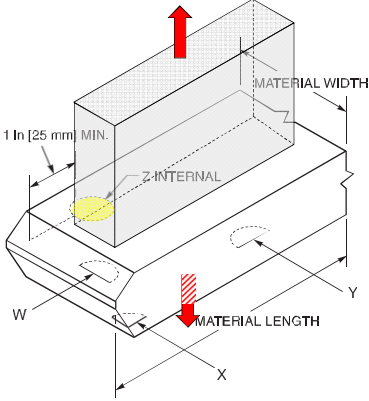

54

**PROBLEMS AND FIXES**

**Repairs to Cut Edges (Mill Induced): Summary**

- Length and depth determine acceptability and permitted repairs
- Explore by grinding, not AAG
- Excessive inclusions may render the steel unacceptable



55

**PROBLEMS AND FIXES**

**Chapter 15: Problems and Fixes**

- 15.1 Repairs to Base Metal
- 15.2 Repairs to Cut Edges
- ➔ 15.3 Butt Joint Alignment
- 15.4 Out-of-Tolerance Weld Joints
- 15.5 Fixing Members that are Cut Short
- 15.6 Repair of Mislocated Holes
- 15.7 Use of Plug Welds in Lieu of Bolts
- 15.8 Repairs to Welds



56



**AWS D1.1:2015 Structural Welding Code--Steel**

### 5.21.3 Butt Joint Alignment.

Parts to be joined at butt joints shall be carefully aligned. Where the parts are effectively restrained against bending due to eccentricity in alignment, the offset from the theoretical alignment shall not exceed 10% of the thickness of the thinner part joined, or 1/8 in [3 mm], whichever is smaller.

In correcting misalignment in such cases, the parts shall not be drawn in to a greater slope than 1/2 in [12 mm] in 12 in [300 mm]. Measurement of offset shall be based upon the centerline of parts unless otherwise shown on the drawings.

**1/2 in 12 = 1 in 24**



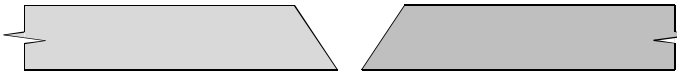

57

**PROBLEMS AND FIXES**



**Ideal**



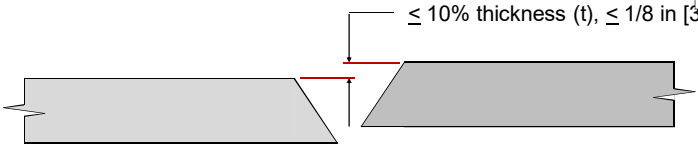

58

**PROBLEMS AND FIXES**



$\leq 10\% \text{ thickness } (t), \leq 1/8 \text{ in [3 mm]}$

**Acceptable**



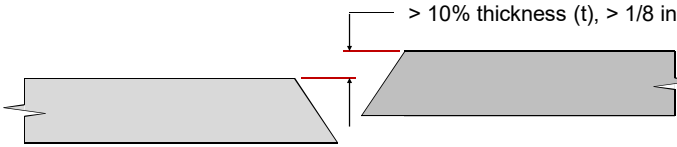

59

**PROBLEMS AND FIXES**



$> 10\% \text{ thickness } (t), > 1/8 \text{ in [3 mm]}$

**Now what?**



60

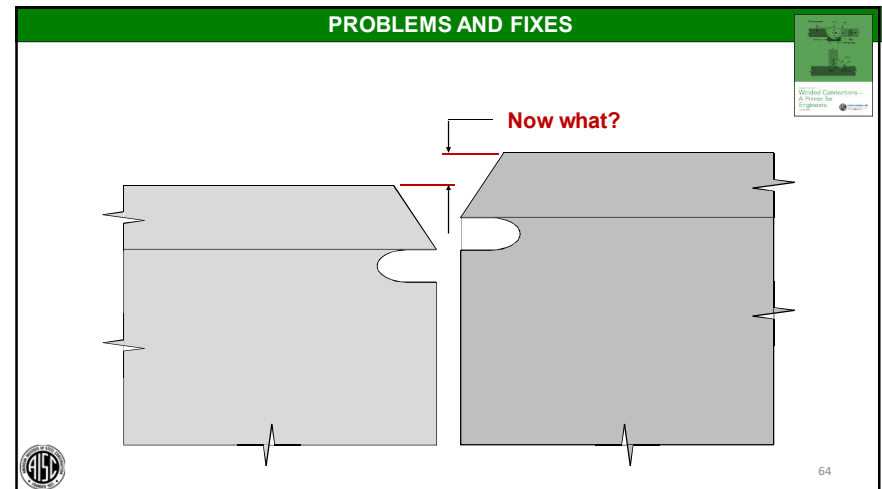
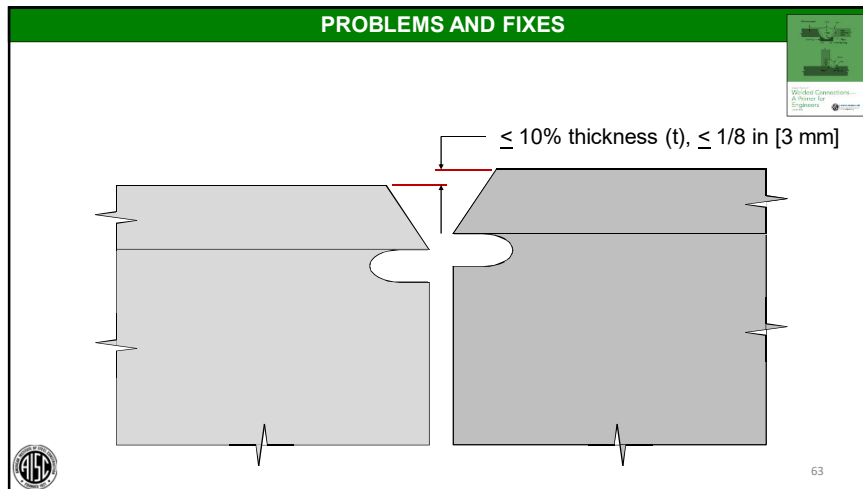
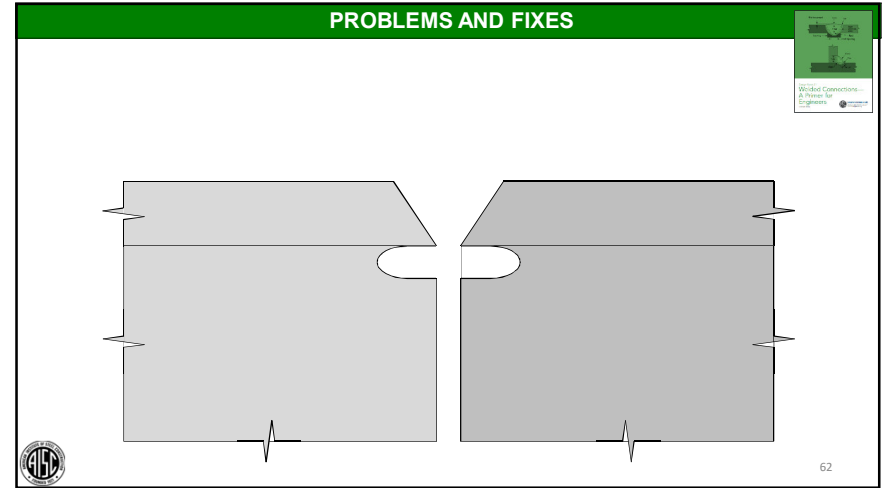
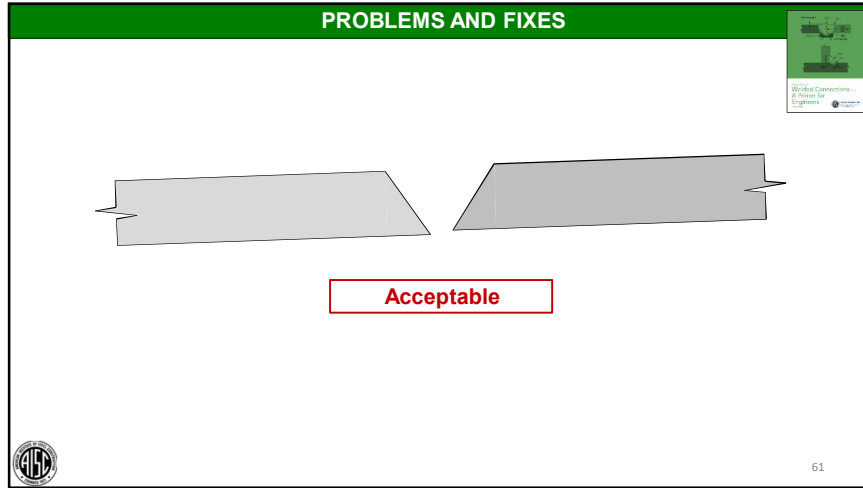

**AWS D1.1:2015 Structural Welding Code--Steel**

### 6.8 Engineer's Approval for Alternate Acceptance Criteria

The fundamental premise of the code is to provide general stipulations applicable to most situations. Acceptance criteria for production welds different from those described in the code may be used for a particular application, provided they are suitably documented by the proposer and approved by the Engineer. These alternate acceptance criteria may be based upon evaluation of suitability for service using past experience, experimental evidence or engineering analysis considering material type, service load effects, and environmental factors.



65

**PROBLEMS AND FIXES**

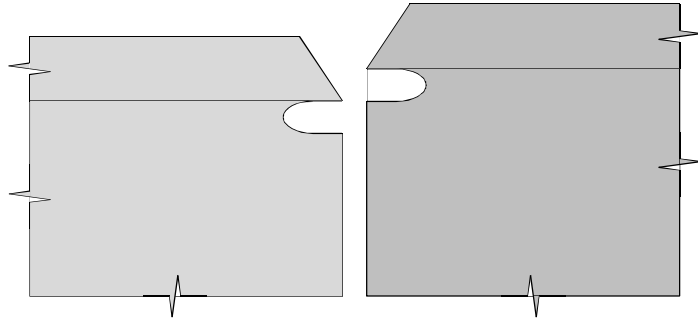

66

**PROBLEMS AND FIXES**

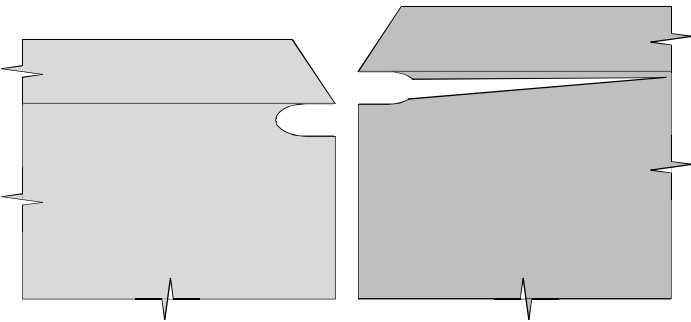

67

**PROBLEMS AND FIXES**

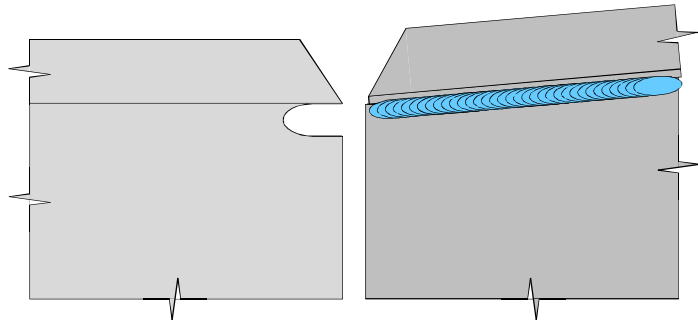

68

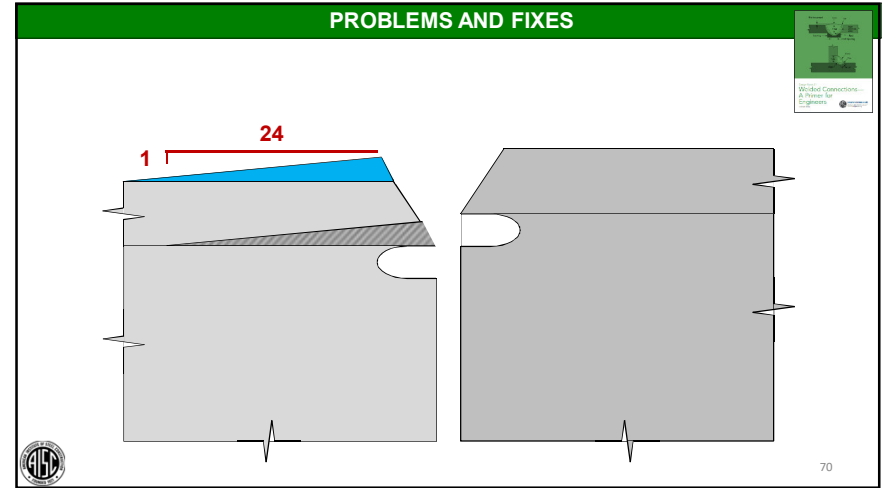
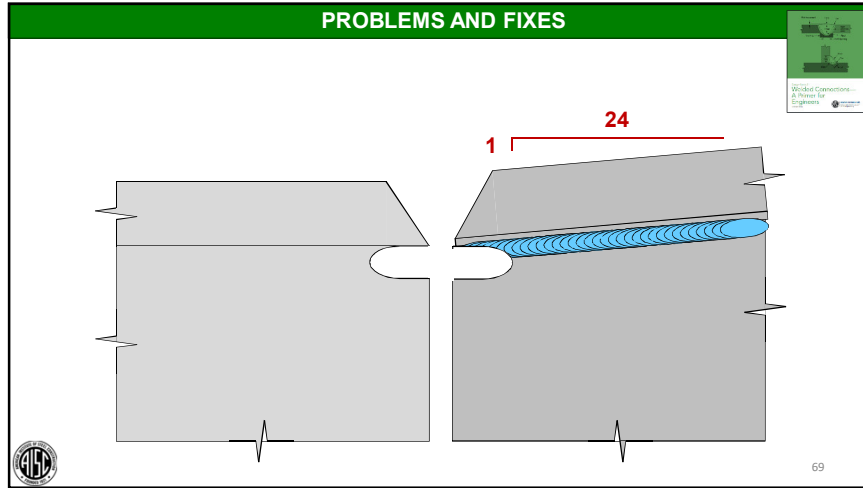

PROBLEMS AND FIXES

**1 in 24 ratio**

| Offset         | Length         |
|----------------|----------------|
| 1/4 in (6 mm)  | 6 in (150 mm)  |
| 1/2 in (12 mm) | 12 in (300 mm) |
| 3/4 in (18 mm) | 18 in (450 mm) |
| 1 in (25 mm)   | 24 in (600 mm) |

71

**AWS D1.1:2015 Structural Welding Code--Steel**

**5.21.3 Butt Joint Alignment.**

Parts to be joined at butt joints shall be carefully aligned. Where the parts are effectively restrained against bending due to eccentricity in alignment, the offset from the theoretical alignment shall not exceed 10% of the thickness of the thinner part joined, or 1/8 in [3 mm], whichever is smaller.

In correcting misalignment in such cases, the parts shall not be drawn in to a greater slope than 1/2 [12 mm] in 12 in [300 mm]. Measurement of offset shall be based upon the centerline of parts unless otherwise shown on the drawings.

72

**PROBLEMS AND FIXES**

2 in (25 mm)

1/8 in (3 mm)

**Acceptable**

73

**PROBLEMS AND FIXES**

2 in (25 mm)

1/4 in (6 mm)

**Does it matter?**

74

**PROBLEMS AND FIXES**

**15.3 Butt Joint Alignment: Summary**

- Code provides limits: smaller of 10% thickness or 1/8 in (3 mm)
- For restrained members, 1: 24 slope
- EOR could permit alternative criteria

75

**PROBLEMS AND FIXES**

**Chapter 15: Problems and Fixes**

- 15.1 Repairs to Base Metal
- 15.2 Repairs to Cut Edges
- 15.3 Butt Joint Alignment
- ➔ 15.4 Out-of-Tolerance Weld Joints
- 15.5 Fixing Members that are Cut Short
- 15.6 Repair of Mislocated Holes
- 15.7 Use of Plug Welds in Lieu of Bolts
- 15.8 Repairs to Welds

76

**PROBLEMS AND FIXES**

**15.4 Out-of-tolerance Weld Joints**

- 15.4.1 Sources of Fit-Up Variation
- ➔ 15.4.2 Fit-Up Problems with Fillet Welded Joints
- 15.4.3 Fit-Up Problems with CJP Groove Welded Joints
- 15.4.4 Fit-Up Problems with PJP Groove Welded Joints
- 15.4.5 Fit-Up Problems with Plug and Slot Welded Joints



77

**AWS D1.1:2015 Structural Welding Code--Steel**

**5.21.1 Fillet Weld Assembly.**

The parts to be joined by fillet welds shall be brought into as close contact as practicable. The root opening shall not exceed 3/16 in [5 mm] except in cases involving either shapes or plates 3 in [75 mm] or greater in thickness if, after straightening and in assembly, the root opening cannot be closed sufficiently to meet this tolerance...a maximum root opening of 5/16 in [8 mm] may be used, provided suitable backing is used.



78

**PROBLEMS AND FIXES**

**Ideal**

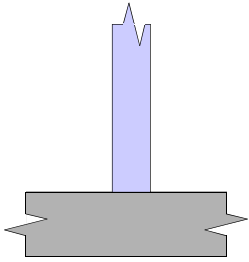

**Permitted without correction**

$\leq 1/16$  in.  
[2 mm]

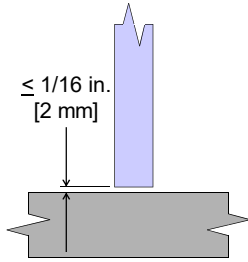



79

**PROBLEMS AND FIXES**

**Permitted with correction**

$\leq 3/16$  in.  
[5 mm]

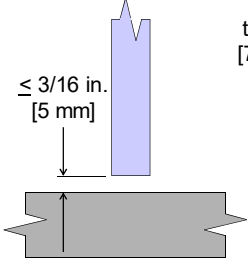

$t \geq 3$  in.  
[75 mm]

$\leq 5/16$  in.  
[8 mm]

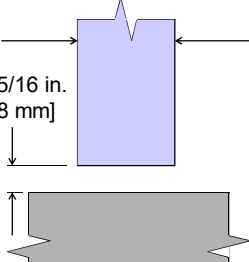



80

**PROBLEMS AND FIXES**

$\geq 3/16$  in.  
[5 mm]

**Now what?**

$t \geq 3$  in.  
[75 mm]

$\geq 5/16$  in.  
[8 mm]

81

**AWS D1.1:2015 Structural Welding Code--Steel**

**6.8 Engineer's Approval for Alternate Acceptance Criteria**

The fundamental premise of the code is to provide general stipulations applicable to most situations. **Acceptance criteria for production welds different from those described in the code may be used for a particular application, provided they are suitably documented by the proposer and approved by the Engineer.** These alternate acceptance criteria may be based upon evaluation of suitability for service using past experience, experimental evidence or engineering analysis considering material type, service load effects, and environmental factors.

- 

82

**PROBLEMS AND FIXES**

**Design Guide Option 1: Buttering**

83

**PROBLEMS AND FIXES**

**Design Guide Option 1: Buttering**

84

**PROBLEMS AND FIXES**

**Design Guide Option 1: Buttering**

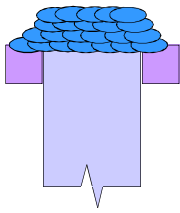

The diagram shows a light blue vertical plate with a jagged bottom edge. On top of the plate, there are two purple rectangular flanges. A thick, wide layer of blue, textured material (representing a weld) is applied across the top of the plate and the flanges, creating a flat, wide surface.



85

**PROBLEMS AND FIXES**

**Design Guide Option 1: Buttering**

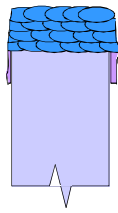

The diagram shows a light blue vertical plate with a jagged bottom edge. On top of the plate, there are two purple rectangular flanges. A layer of blue, textured material (representing a weld) is applied across the top of the plate and the flanges, but it is narrower and more raised than in the previous diagram.



86

**PROBLEMS AND FIXES**

**Design Guide Option 1: Buttering**



The diagram shows a light blue vertical plate with a jagged bottom edge. On top of the plate, there are two purple rectangular flanges. A thin, flat layer of blue, textured material (representing a weld) is applied across the top of the plate and the flanges.



87

**PROBLEMS AND FIXES**

**Design Guide Option 1: Buttering**



The diagram shows a light blue vertical plate with a jagged bottom edge. On top of the plate, there are two purple rectangular flanges. A thin, flat layer of blue, textured material (representing a weld) is applied across the bottom of the plate and the flanges.





88

**PROBLEMS AND FIXES**

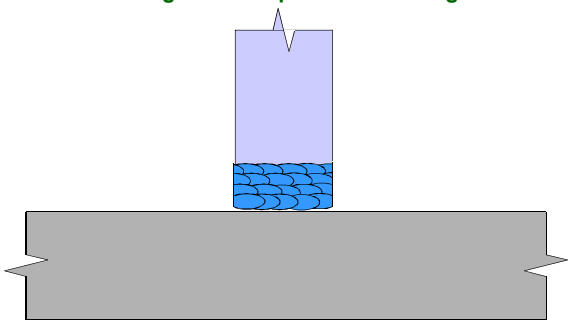
**Design Guide Option 1: Buttering**



The diagram shows a vertical purple plate on a horizontal grey base. A blue, wavy line representing a buttering weld is shown at the interface between the plate and the base. The plate has a jagged top edge. The base has jagged ends.



89

**PROBLEMS AND FIXES**

**Design Guide Option 2: Change to CJP groove weld**

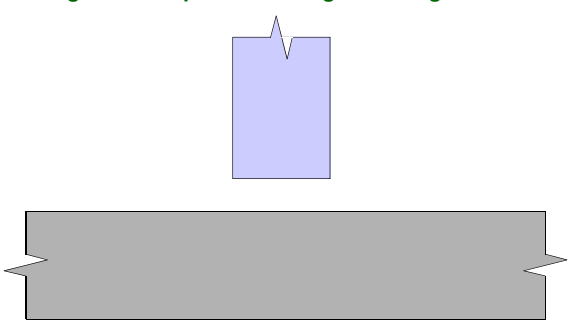

The diagram shows a vertical purple plate on a horizontal grey base. A jagged line representing a CJP groove weld is shown at the interface between the plate and the base. The plate has a jagged top edge. The base has jagged ends.



90

**PROBLEMS AND FIXES**

**Design Guide Option 2: Change to CJP groove weld**

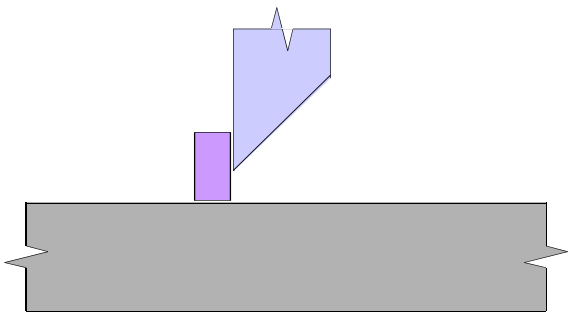

The diagram shows a vertical purple plate on a horizontal grey base. A jagged line representing a CJP groove weld is shown at the interface between the plate and the base. The plate has a jagged top edge. The base has jagged ends.



  

91

**PROBLEMS AND FIXES**

**15.4 Out-of-tolerance Weld Joints**

- 15.4.1 Sources of Fit-Up Variation
- 15.4.2 Fit-Up Problems with Fillet Welded Joints
-  15.4.3 Fit-Up Problems with CJP Groove Welded Joints
- 15.4.4 Fit-Up Problems with PJP Groove Welded Joints
- 15.4.5 Fit-Up Problems with Plug and Slot Welded Joints

92

**PROBLEMS AND FIXES**

**15.4 Out-of-tolerance Weld Joints**

15.4.3 Fit-up Problems with CJP Groove Welded Joints

| Prequalified Joint Details |     | Fitup Problem |           |
|----------------------------|-----|---------------|-----------|
|                            |     | Too Tight     | Too Loose |
| Backing                    | Yes | X             | X         |
|                            | No  | X             | X         |

93

**PROBLEMS AND FIXES**

**15.4 Out-of-tolerance Weld Joints**

15.4.3 Fit-up Problems with CJP Groove Welded Joints

| Prequalified Joint Details |     | Fitup Problem |           |
|----------------------------|-----|---------------|-----------|
|                            |     | Too Tight     | Too Loose |
| Backing                    | Yes | X             | X         |
|                            | No  | X             | X         |

94

**PROBLEMS AND FIXES**

**15.4 Out-of-tolerance Weld Joints**

15.4.3 Fit-up Problems with CJP Groove Welded Joints

| Prequalified Joint Details |     | Fitup Problem |           |
|----------------------------|-----|---------------|-----------|
|                            |     | Too Tight     | Too Loose |
| Backing                    | Yes | X             | X         |
|                            | No  | X             | X         |

95

**PROBLEMS AND FIXES**

**15.4 Out-of-tolerance Weld Joints**

15.4.3 Fit-up Problems with CJP Groove Welded Joints

| Prequalified Joint Details |     | Fitup Problem |           |
|----------------------------|-----|---------------|-----------|
|                            |     | Too Tight     | Too Loose |
| Backing                    | Yes | X             | X         |
|                            | No  | X             | X         |

96

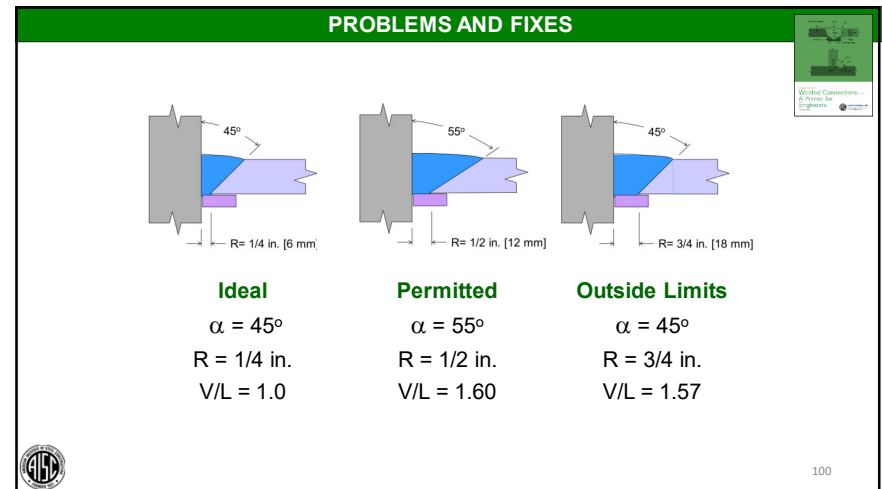
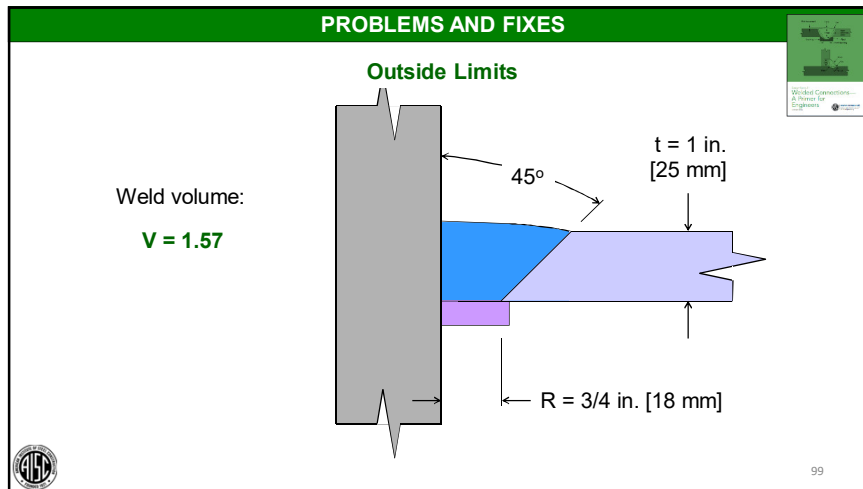
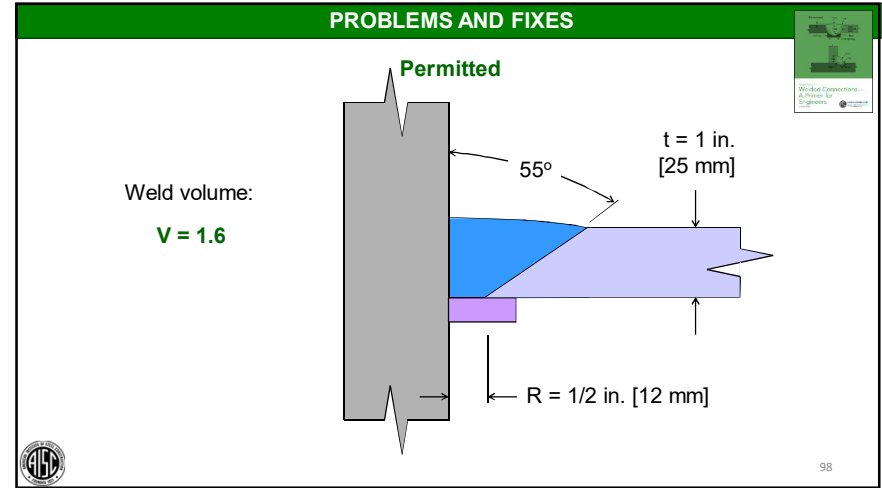
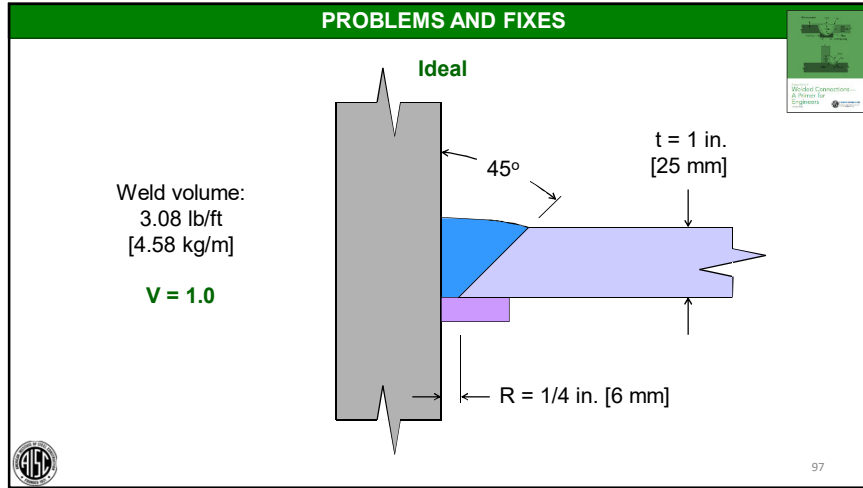

**PROBLEMS AND FIXES**

**DG 21 Suggestion:**

If the volume of weld metal required to weld the joint that is outside limits is less than what is permitted for similar joints with allowed tolerances, the EOR can approve welding of the joint without correction.

101

**AWS D1.1:2015 Structural Welding Code--Steel**

**5.21.4.2 Correction.**

Root openings greater than those allowed in 5.21.4.1, but not greater than twice the thickness of the thinner part or 3/4 in [20 mm], whichever is less, may be corrected by welding to acceptable dimensions prior to joining the parts by welding.

102

**PROBLEMS AND FIXES**

Outside general limits, within clause 5.21.4.2

103

**PROBLEMS AND FIXES**

Outside general limits, within clause 5.21.4.2

104

**PROBLEMS AND FIXES**

Outside general limits, within clause 5.21.4.2

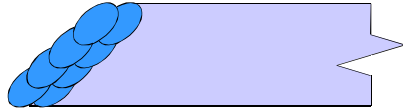

The diagram shows a blue weld joint connecting a vertical grey member to a horizontal purple member. The weld is composed of several overlapping ripples. There is a visible gap (root opening) at the bottom of the joint.

105

**PROBLEMS AND FIXES**

Outside general limits, within clause 5.21.4.2

Permitted correction: does not require EOR approval

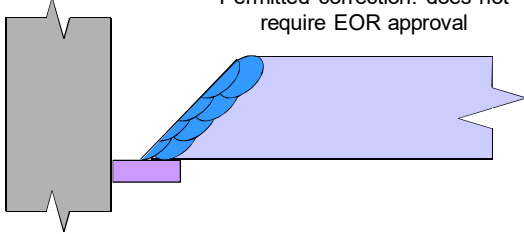

The diagram shows a similar weld joint to slide 105, but with a correction. A purple rectangular patch is applied to the bottom of the joint, filling the root opening. The weld ripples are shown overlapping this patch.

106

**AWS D1.1:2015 Structural Welding Code--Steel**

**5.21.4.3 Engineer's Approval.**  
Root openings greater than allowed by 5.21.4.2 may be corrected by welding only with the approval of the Engineer.



A small inset diagram showing a weld joint with a root opening, similar to the one in slide 105.

107

**PROBLEMS AND FIXES**

Outside general limits, outside limits of clause 5.21.4.2

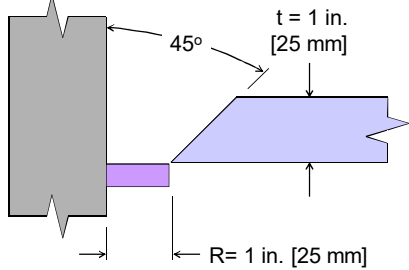

The diagram shows a weld joint with a root opening. A purple rectangular patch is applied to the bottom of the joint. The weld ripples are shown overlapping this patch. Dimensions are provided: a 45-degree angle for the top edge of the patch, a thickness  $t = 1 \text{ in. [25 mm]}$ , and a radius  $R = 1 \text{ in. [25 mm]}$ .

108

**PROBLEMS AND FIXES**

Outside general limits, outside limits of clause 5.21.4.2

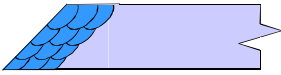

Welded Connections – A Primer for Engineers

109

**PROBLEMS AND FIXES**

Outside general limits, outside limits of clause 5.21.4.2

Requires EOR approval

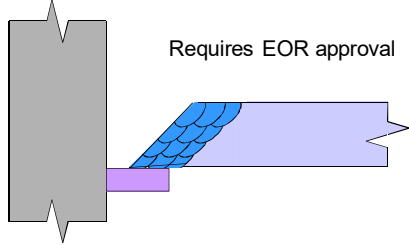

Welded Connections – A Primer for Engineers

110

**PROBLEMS AND FIXES**

**Ideal**

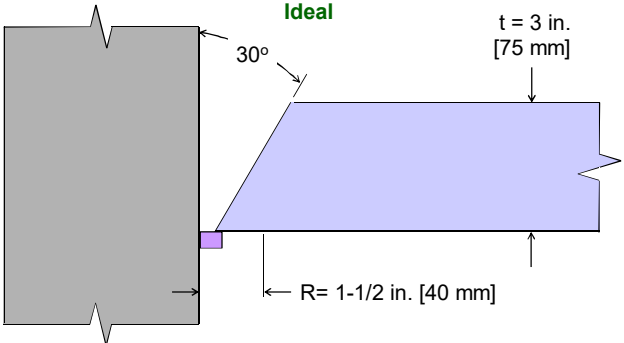

Welded Connections – A Primer for Engineers

111

**PROBLEMS AND FIXES**

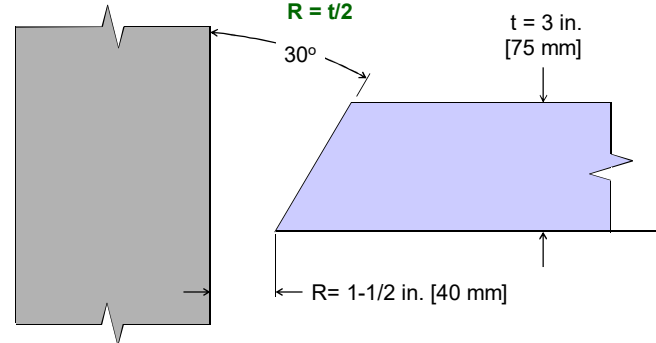

Welded Connections – A Primer for Engineers

112

**PROBLEMS AND FIXES**

**Butter Option**

$t = 3 \text{ in. [75 mm]}$

Butter = 1-1/8 in. [28 mm]

113

**PROBLEMS AND FIXES**

**Splice Option**

114

**PROBLEMS AND FIXES**

**Splice Option**

115

**PROBLEMS AND FIXES**

**Splice Option**

116

**PROBLEMS AND FIXES**

**Butter Option**

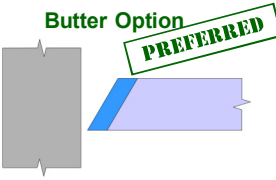

**PREFERRED**

**Splice Option**

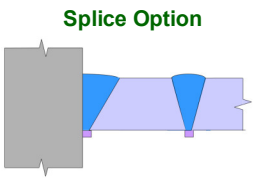

- Both require EOR approval
- Both require similar amounts of welding
- Buttering is a simpler solution

117

**PROBLEMS AND FIXES**

**15.4 Out-of-tolerance Weld Joints**

15.4.3 Fit-up Problems with CJP Groove Welded Joints

| Prequalified Joint Details | Fitup Problem |           |
|----------------------------|---------------|-----------|
|                            | Too Tight     | Too Loose |
| <b>Backing</b>             | Yes<br>X      | X         |
|                            | No            | <b>X</b>  |

118

**PROBLEMS AND FIXES**

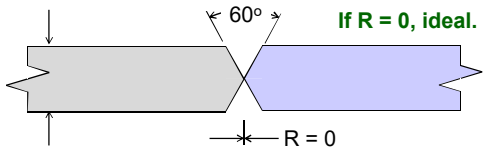

**If R = 0, ideal.**

R = 0

t = 1 in.  
[25 mm]

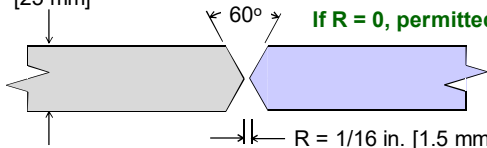

**If R = 0, permitted.**

R = 1/16 in. [1.5 mm]

119

**PROBLEMS AND FIXES**

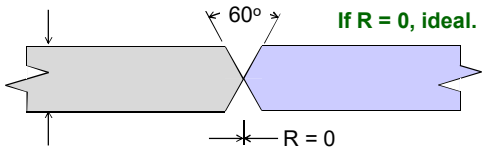

**If R = 0, ideal.**

R = 0

t = 1 in.  
[25 mm]

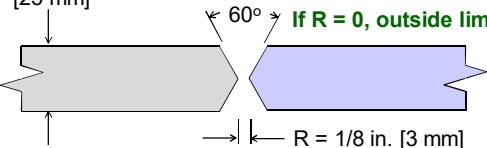

**If R = 0, outside limits.**

R = 1/8 in. [3 mm]

120

**AWS D1.1:2015 Structural Welding Code--Steel**

**5.21.4.2 Correction.**

Root openings greater than those allowed in 5.21.4.1, but not greater than twice the thickness of the thinner part or 3/4 in [20 mm], whichever is less, may be corrected by welding to acceptable dimensions prior to joining the parts by welding.



121

**PROBLEMS AND FIXES**

122

**PROBLEMS AND FIXES**

123

**PROBLEMS AND FIXES**

**Butter**  
 (requires EOR approval)

**Outside limits of 5.21.4.2**

124

**PROBLEMS AND FIXES**

**Insert**  
(requires EOR approval)

Outside limits  
of 5.21.4.2

60°

t = 1 in.  
[25 mm]

R = 1 in. [25 mm]

125

**PROBLEMS AND FIXES**

**Insert**  
(requires EOR approval)

126

**PROBLEMS AND FIXES**

**Insert**  
(requires EOR approval)

127

**PROBLEMS AND FIXES**

**Insert**  
(requires EOR approval)

128

**PROBLEMS AND FIXES**

**Insert**  
(requires EOR approval)

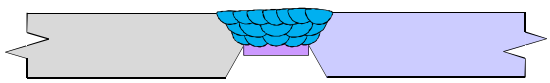

The diagram shows two steel plates, one grey and one purple, joined by a blue weld. A purple insert is positioned on the top surface of the joint, between the two plates.

 129

**PROBLEMS AND FIXES**

**Insert**  
(requires EOR approval)

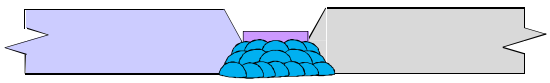

The diagram shows two steel plates, one purple and one grey, joined by a blue weld. A purple insert is positioned on the bottom surface of the joint, between the two plates.

 130

**PROBLEMS AND FIXES**

**Insert**  
(requires EOR approval)

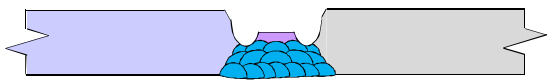

The diagram shows two steel plates, one purple and one grey, joined by a blue weld. A purple insert is positioned on the bottom surface of the joint, between the two plates.

 131

**PROBLEMS AND FIXES**

**Insert**  
(requires EOR approval)

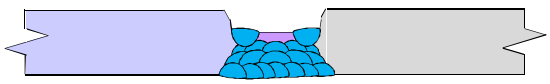



The diagram shows two steel plates, one purple and one grey, joined by a blue weld. A purple insert is positioned on the bottom surface of the joint, between the two plates.

 132

**PROBLEMS AND FIXES**

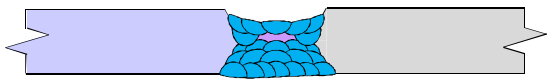
**Insert**  
(requires EOR approval)



 133

**PROBLEMS AND FIXES**

**Insert**  
(requires EOR approval)

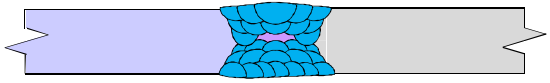

 134

**PROBLEMS AND FIXES**

**15.4 Out-of-Tolerance Weld Joints: Summary**

- The code provides limits, primarily based on workmanship
- The code provides solutions for problems, within limits
- The EOR can extend those limits
- DG21 provides alternatives the EOR can consider

 135

**PROBLEMS AND FIXES**

**Chapter 15: Problems and Fixes**

- 15.1 Repairs to Base Metal
- 15.2 Repairs to Cut Edges
- 15.3 Butt Joint Alignment
- 15.4 Out-of-Tolerance Weld Joints
- ➔ 15.5 Fixing Members that are Cut Short
- 15.6 Repair of Mislocated Holes
- 15.7 Use of Plug Welds in Lieu of Bolts
- 15.8 Repairs to Welds

 136

**PROBLEMS AND FIXES**

**15.5 Fixing Members That Are Cut Short**

Gap = 1 - 2 in. [25 - 50 mm]

**Buttering may be a good solution**

137

**PROBLEMS AND FIXES**

**15.5 Fixing Members That Are Cut Short**

Gap = 3 - 4 in. [75 - 100 mm]

**Buttering probably not a good solution**

138

**PROBLEMS AND FIXES**

**15.5 Fixing Members That Are Cut Short**

Gap = 3 - 4 in. [75 - 100 mm]

**Use an insert?**

139

**PROBLEMS AND FIXES**

**15.5 Fixing Members That Are Cut Short**

Gap = 3 - 4 in. [75 - 100 mm]

**Use an insert?**

140

**PROBLEMS AND FIXES**

**15.5 Fixing Members That Are Cut Short**

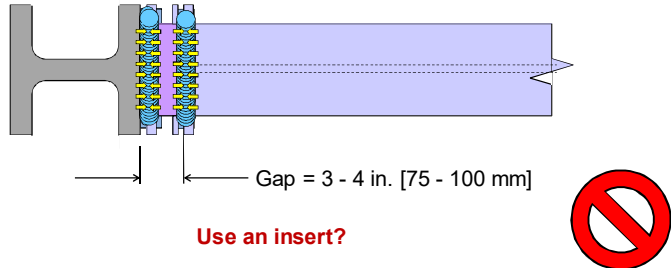

Gap = 3 - 4 in. [75 - 100 mm]

**Use an insert?**

141

This diagram shows a cross-section of an H-beam with a gap between the flange and the web. The gap is filled with bolts and washers. A red prohibition sign is placed to the right of the diagram, indicating that this method is not recommended.

**PROBLEMS AND FIXES**

**15.5 Fixing Members That Are Cut Short**

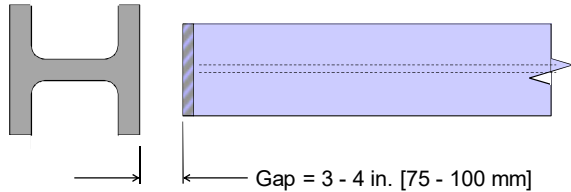

Gap = 3 - 4 in. [75 - 100 mm]

**Install a larger insert**

142

This diagram shows a cross-section of an H-beam with a gap between the flange and the web. A red prohibition sign is placed to the right of the diagram, indicating that this method is not recommended.

**PROBLEMS AND FIXES**

**15.5 Fixing Members That Are Cut Short**

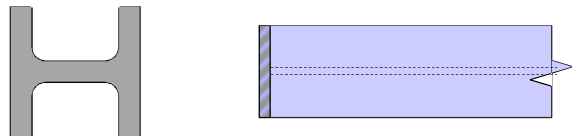

**DG suggestion: install a larger insert**

143

This diagram shows a cross-section of an H-beam with a gap between the flange and the web.

**PROBLEMS AND FIXES**

**15.5 Fixing Members That Are Cut Short**

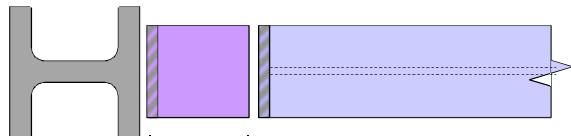

Insert = flange width,  
not < 12 in [300 mm]

**DG suggestion: install a larger insert**

144

This diagram shows a cross-section of an H-beam with a gap between the flange and the web. A purple insert is shown between the flange and the web. A red prohibition sign is placed to the right of the diagram, indicating that this method is not recommended.

**AWS D1.1:2015 Structural Welding Code--Steel**

### 5.12 Conformance with Design

The sizes and lengths of welds shall be no less than those specified by design requirements and detail drawings, except as allowed in Table 6.1 or Table 9.16. The location of welds shall not be changed without approval of the Engineer.



145

**PROBLEMS AND FIXES**

### 15.5 Fixing Members that are Cut Short

- Buttering may be an option (EOR must approve)
- Using an insert may be an option (EOR must approve)
- DG21 advise: make insert flange width or 12 in [300 mm] minimum to separate the two parallel welds



146

**PROBLEMS AND FIXES**

### Chapter 15: Problems and Fixes

- 15.1 Repairs to Base Metal
- 15.2 Repairs to Cut Edges
- 15.3 Butt Joint Alignment
- 15.4 Out-of-Tolerance Weld Joints
- 15.5 Fixing Members that are Cut Short
- ➔ 15.6 Repair of Mislocated Holes
- 15.7 Use of Plug Welds in Lieu of Bolts
- 15.8 Repairs to Welds



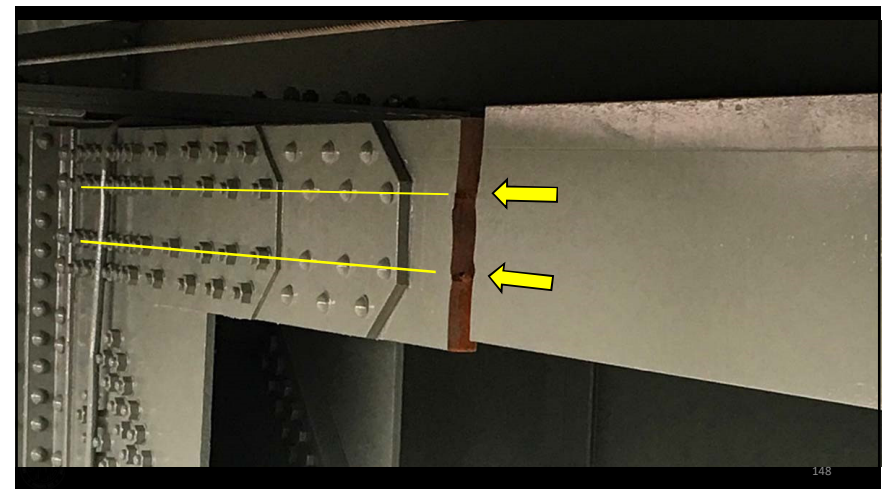

147



**AWS D1.1:2015 Structural Welding Code--Steel**

**5.25.5 Welded Restoration of Base Metal with Mislocated Holes.**  
Except where restoration by welding is necessary for structural or other reasons, punched or drilled mislocated holes may be left open or filled with bolts.





149

**AWS D1.1:2015 Structural Welding Code--Steel**

**5.25.5 Welded Restoration of Base Metal with Mislocated Holes (cont'd).**  
When base metal with mislocated holes is restored by welding, the following requirements apply:

(three situations follow)



**Static**                      **Cyclic**                      **Q&T**



150

**AWS D1.1:2015 Structural Welding Code--Steel**



**C-5.25.5 Welded Restoration of Base Metal with Mislocated Holes.**  
The technique for making plug welds set forth in 5.24.1 of this code is not satisfactory for restoring the entire cross section of the base metal at mislocated holes. Plug welds are intended to transmit shear from one plane surface to another and not to develop the full cross section of the hole.



151

**AWS D1.1:2015 Structural Welding Code--Steel**

**C-5.25.5 Welded Restoration of Base Metal with Mislocated Holes (cont'd).**  
One method of restoring unacceptable holes is to fill one-half the depth or less with steel backing of the same material specification as the base metal, gouge an elongated boat-shaped cavity down to the backing, then fill the cavity by welding using the stringer bead technique.



152

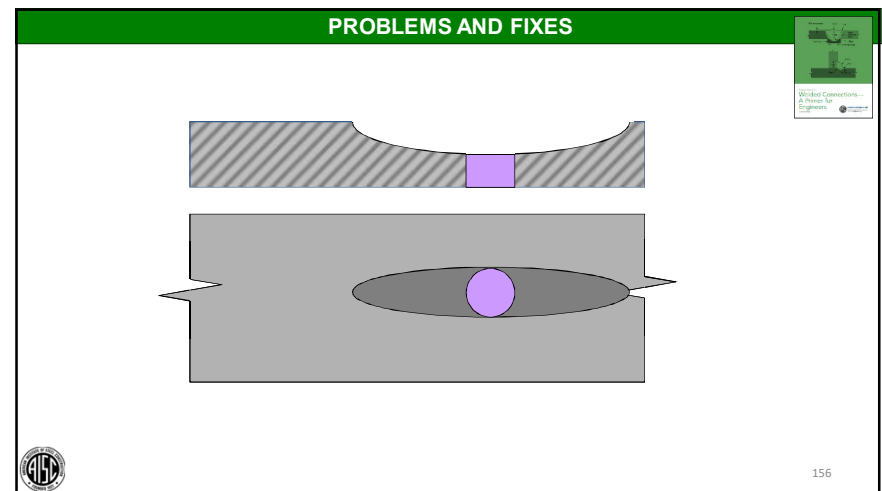
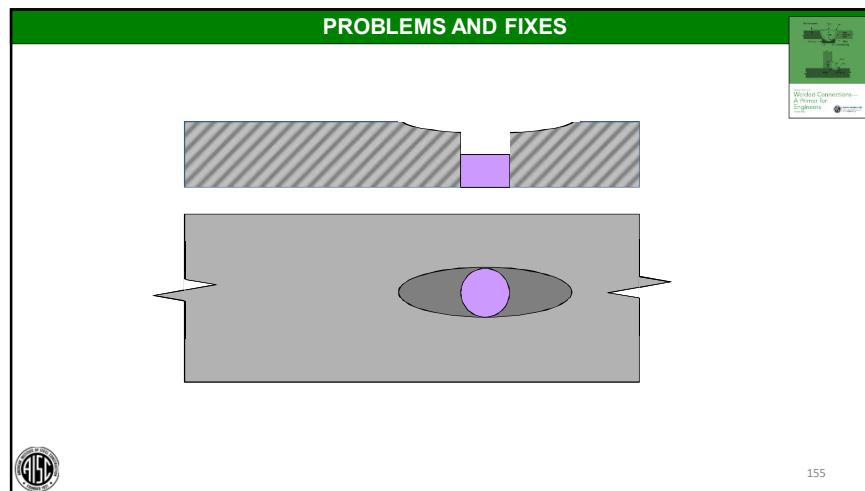
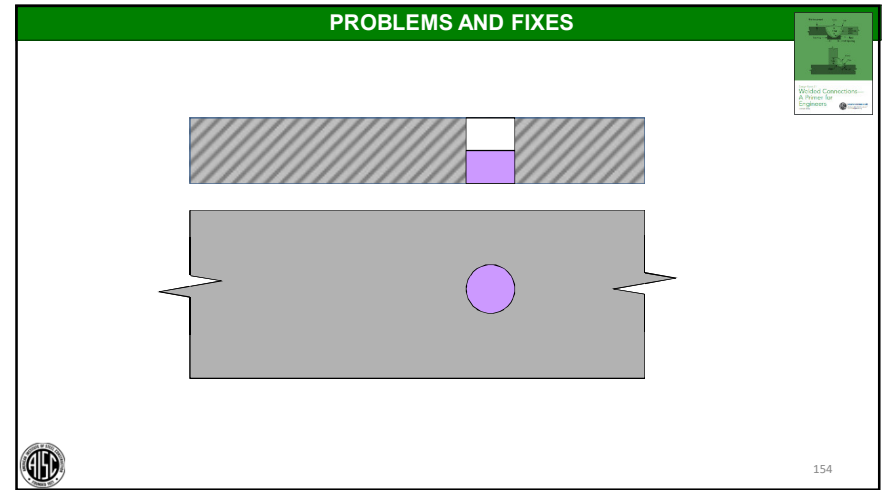
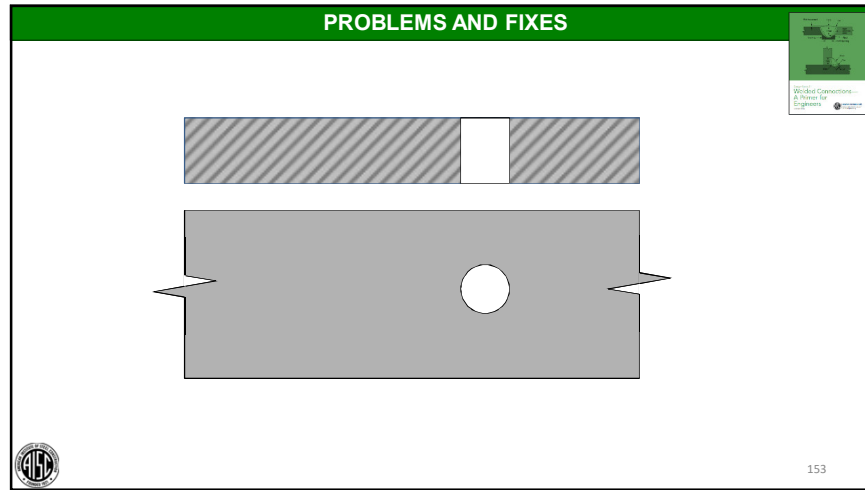

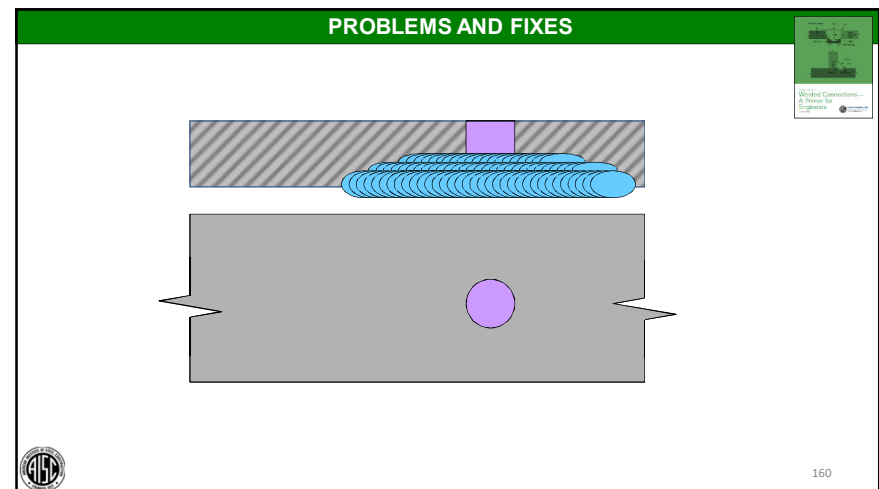
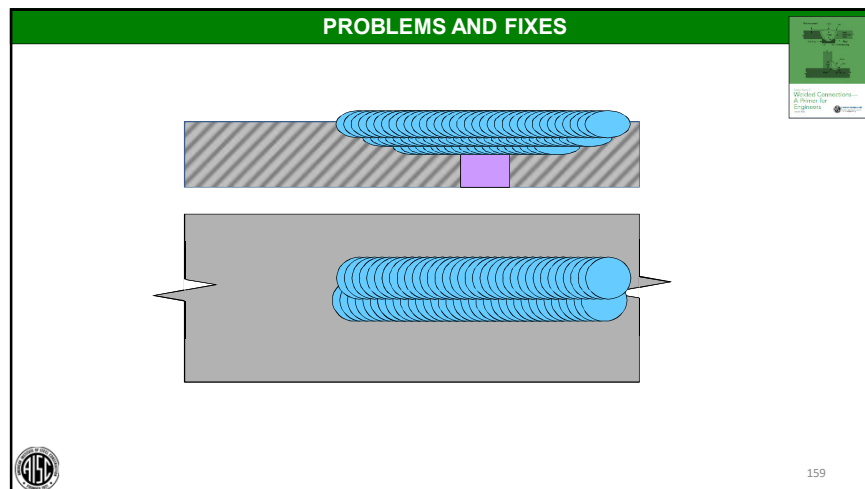
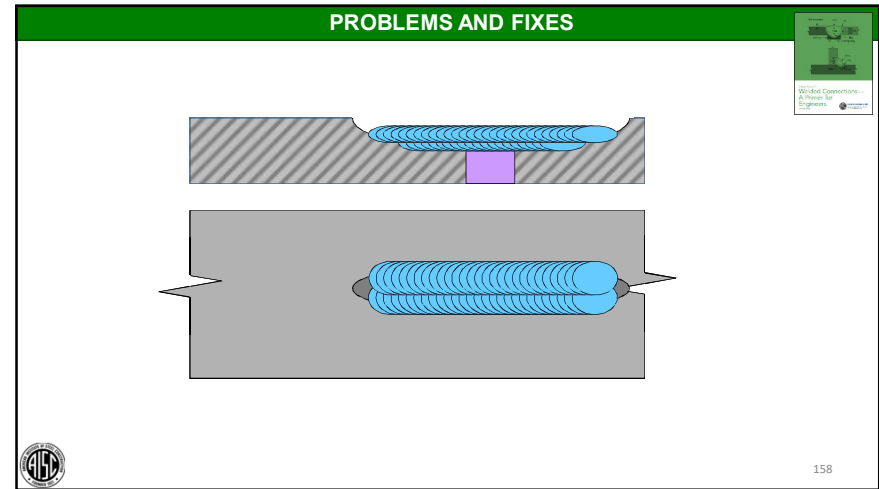
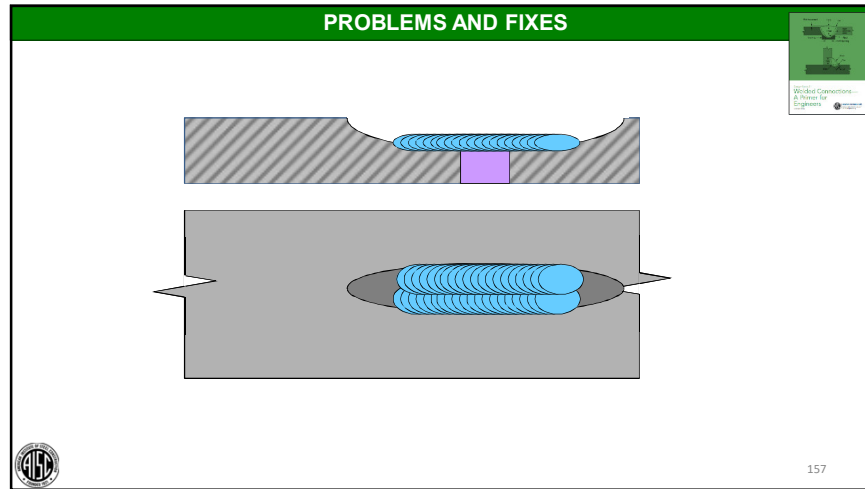

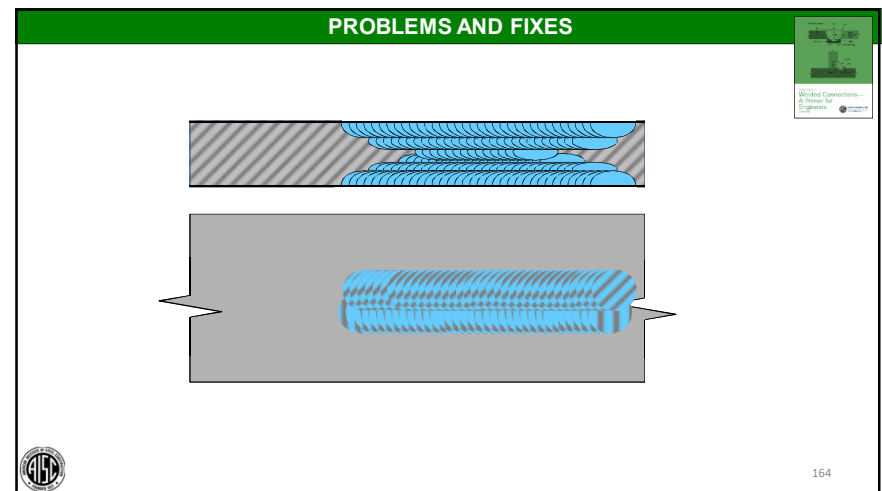
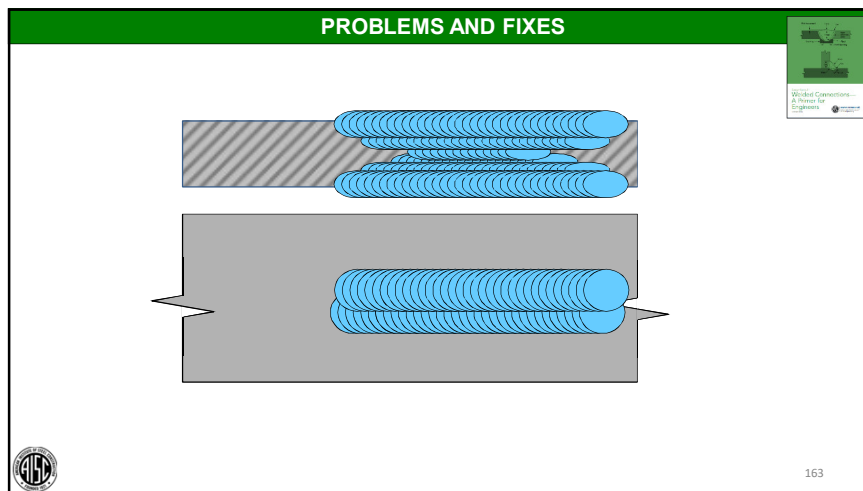
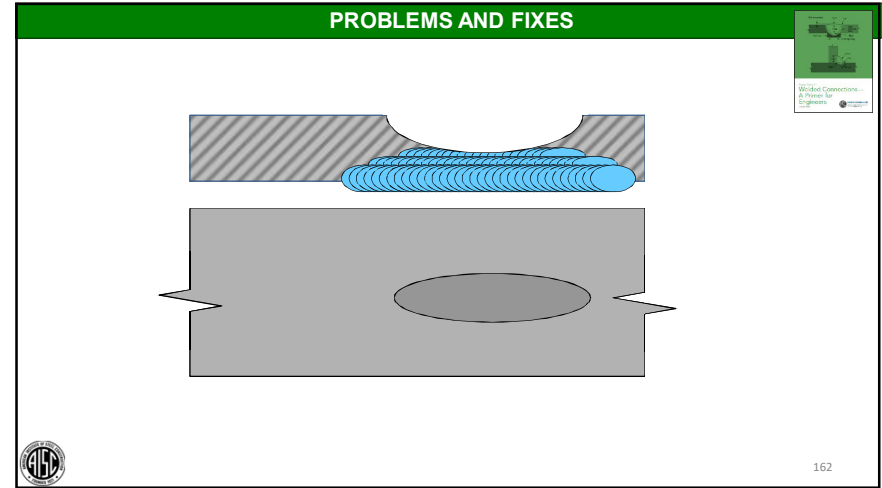
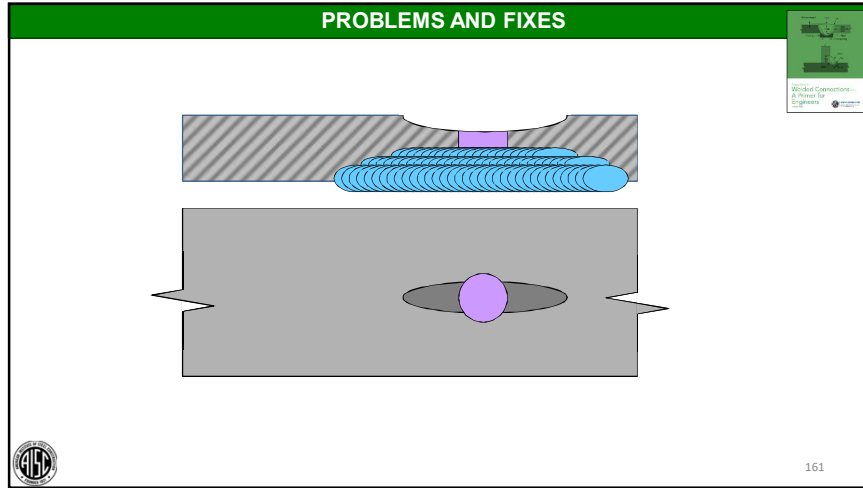

**AWS D1.1:2015 Structural Welding Code--Steel**

**5.25.5 Welded Restoration of Base Metal with Mislocated Holes.**  
Except where restoration by welding is necessary for structural or other reasons, punched or drilled mislocated holes may be left open or filled with bolts.



165

**AWS D1.1:2015 Structural Welding Code--Steel**

**5.25.5 Welded Restoration of Base Metal with Mislocated Holes.**  
Except where restoration by welding is necessary for structural or other reasons, punched or drilled mislocated holes may be left open or filled with bolts.



166

**PROBLEMS AND FIXES**

**15.6 Repair of Mislocated Holes: Summary**

- Caution: improperly repaired holes have been a problem, particularly for cyclically loaded structures
- Leaving the hole unfilled, or inserting a bolt, are good options
- If a weld repair is required, carefully follow code requirements and commentary recommendations



167

**PROBLEMS AND FIXES**

**Chapter 15: Problems and Fixes**

- 15.1 Repairs to Base Metal
- 15.2 Repairs to Cut Edges
- 15.3 Butt Joint Alignment
- 15.4 Out-of-Tolerance Weld Joints
- 15.5 Fixing Members that are Cut Short
- 15.6 Repair of Mislocated Holes
- ➔ 15.7 Use of Plug Welds in Lieu of Bolts
- 15.8 Repairs to Welds



168

**PROBLEMS AND FIXES**

**15.7 Use Of Plug Welds In Lieu Of Bolts**

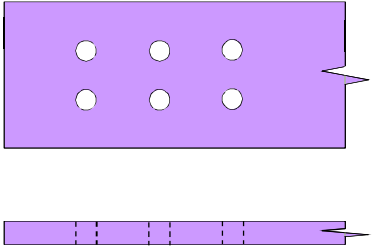

169

Welded Connections... A Primer for Engineers

**PROBLEMS AND FIXES**

**15.7 Use Of Plug Welds In Lieu Of Bolts**

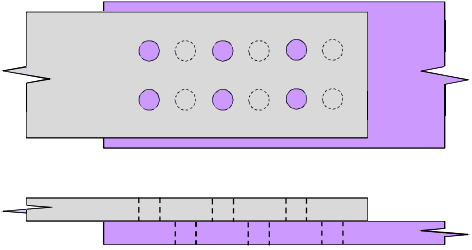

170

Welded Connections... A Primer for Engineers

**PROBLEMS AND FIXES**

**15.7 Use Of Plug Welds In Lieu Of Bolts**

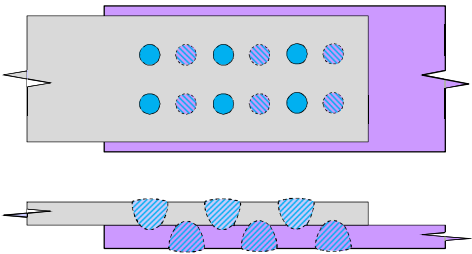

171

Welded Connections... A Primer for Engineers

**PROBLEMS AND FIXES**

**Concerns with plug welds**

- Original hole was not optimized for plug welding
- Plug weld does not have the capacity of a high strength bolt
- Welding position must be considered; only flat position plug welds are easily made
- For cyclically loaded connections, plug welds have poor fatigue performance (Category E, F)
- Plug welds are assumed to be loaded in shear
- Bolted connection limit states may be different than plug welded connection limit states

172

Welded Connections... A Primer for Engineers

**PROBLEMS AND FIXES**

**Drill new holes and install more bolts**

173

**PROBLEMS AND FIXES**

**Drill new holes and install more bolts**

174

**PROBLEMS AND FIXES**

**Drill new holes and install more bolts**

175

**PROBLEMS AND FIXES**

**Weld hole and re-drill**

176

**PROBLEMS AND FIXES**

**Weld hole and re-drill**

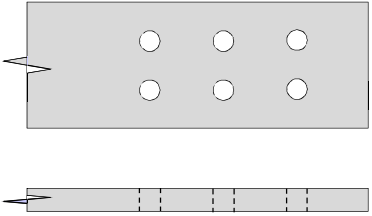

177

This diagram shows a steel plate with six circular holes arranged in two rows of three. Below the plate is a weld line represented by a series of dashed lines, indicating the intended weld path.

**PROBLEMS AND FIXES**

**Weld hole and re-drill**

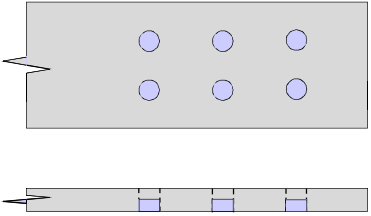

178

This diagram is similar to slide 177, but the six circular holes and the weld line below them are highlighted in blue, indicating they are the focus of the problem or fix.

**PROBLEMS AND FIXES**

**Weld hole and re-drill**

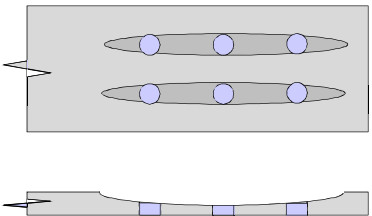

179

This diagram is similar to slide 178, but the holes and weld line are highlighted in blue. The weld line is shown with a slight curve, suggesting a specific welding technique or a problem with the weld.

**PROBLEMS AND FIXES**

**Weld hole and re-drill**

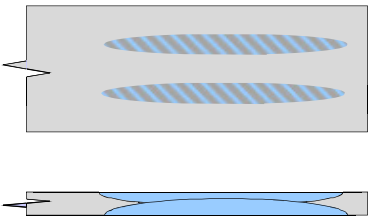

180

This diagram shows a steel plate with two elongated, shaded regions (possibly representing welds or defects) and a weld line below it. The shaded regions and the weld line are highlighted in blue, indicating they are the focus of the problem or fix.

**PROBLEMS AND FIXES**

**Weld hole and re-drill**

The diagram illustrates a weld hole in a steel plate. The top part shows a cross-section of a plate with a weld joint. The weld metal is shaded with blue diagonal lines. A hole is shown in the plate, with a jagged, irregular edge. The bottom part shows a cross-section of a re-drilled hole, with a smooth, circular edge and a blue shaded interior.

 181

**PROBLEMS AND FIXES**

**Weld hole and re-drill**

The diagram illustrates a weld hole in a steel plate. The top part shows a cross-section of a plate with a weld joint. The weld metal is shaded with blue diagonal lines. A hole is shown in the plate, with a jagged, irregular edge. The bottom part shows a cross-section of a re-drilled hole, with a smooth, circular edge and a blue shaded interior. A purple shaded area is shown on the right side of the plate, representing a weld overlay.

 182

**PROBLEMS AND FIXES**

**Drill oversized holes and install larger bolts**

The diagram illustrates oversized holes in a steel plate. The top part shows a cross-section of a plate with a weld joint. The weld metal is shaded with blue diagonal lines. Two holes are shown in the plate, with jagged, irregular edges. The bottom part shows a cross-section of two larger bolts, with a blue shaded interior.

 183

**PROBLEMS AND FIXES**

**Drill oversized holes and install larger bolts**

The diagram illustrates oversized holes in a steel plate. The top part shows a cross-section of a plate with a weld joint. The weld metal is shaded with blue diagonal lines. Two holes are shown in the plate, with jagged, irregular edges. The bottom part shows a cross-section of two larger bolts, with a blue shaded interior.

 184

**PROBLEMS AND FIXES**

**Convert holes into slots**

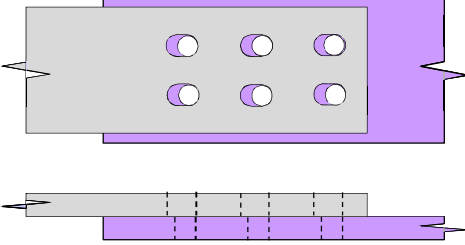

185

**PROBLEMS AND FIXES**

**15.7 Use of Plug Welds in Lieu of Bolts: Summary**

- Plug welds and bolts do not have the same capacity
- Bolt hole sizes are not optimized for plug welding
- Many mechanical options (but, probably more difficult to perform in the field as compared to a plug weld)

186

**PROBLEMS AND FIXES**

- 15.9 Heat Shrinking of Q&T Steel
- 15.10 Unspecified Welds
- 15.11 Welds Made Without Inspection
- ➔ 15.12 Welding on Anchor Rods
- 15.13 Welding Anchor Rod to Base Plates
- 15.14 Removing And Reinstalling Column Base Plates
- 15.15 Repairing Lamellar Tears

187

**PROBLEMS AND FIXES**

**15.12 Welding on Anchor Rods**

- Extending Anchor Rod
- Welding Anchor Rod to Base Plates

188

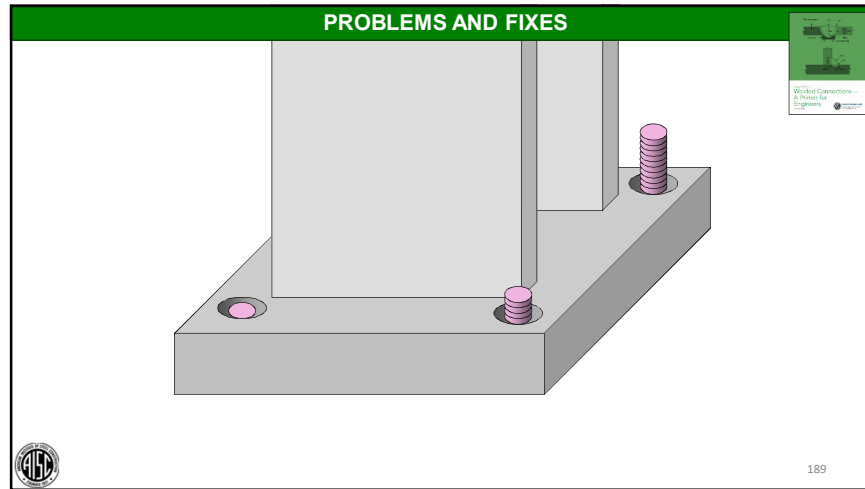

### PROBLEMS AND FIXES

#### Extending Anchor Rods

- Secure the column
- Investigate mechanical options
- Investigate weldability



The AISC logo is in the bottom left corner, and the number 190 is in the bottom right corner.

### AWS STANDARD WELDING TERMS & DEFINITIONS (A3.0:2010)

**weldability.**  
The capacity of a material to be welded under the imposed fabrication conditions into a specific, suitably designed structure performing satisfactorily in the intended service.



The AISC logo is in the bottom left corner, and the number 191 is in the bottom right corner.

### ASTM A6

#### X3. Weldability of Steel

*Weldability* is a term that usually refers to the relative ease with which a metal can be welded using conventional practice.

The AISC logo is in the bottom left corner, and the number 192 is in the bottom right corner.

### AWS STANDARD WELDING TERMS & DEFINITIONS (A3.0:2020)

**weldability.**

The relative ease with which a material may be welded to meet an applicable standard.





193

### PROBLEMS AND FIXES

**Weldability**

- Based on composition
- Driven by carbon content
- Compounded by alloy content
- Related to “hardenability”
- “Hot cracking” concerns as well (S, P, others)

**Remember: weldability is not whether the material can be welded, but rather how easily can the material be welded.**





194

### PROBLEMS AND FIXES

**Weldability Concerns With Anchor Rod Specifications**

- High Carbon
- High Alloy
- Undefined Carbon, Alloy
- Heat Treatment (Q&T)





195

**ASTM A1554-97a**

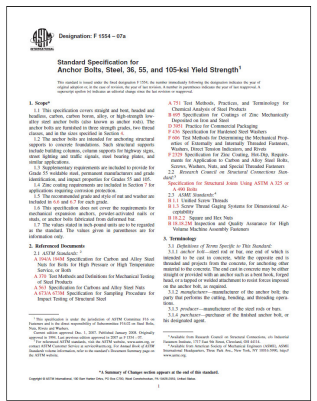
Standard Specification for  
Anchor Bolts, Steel, 36, 55, and  
105-ksi Yield Strength



196

**ASTM A1554-97a**  
Standard Specification for Anchor Bolts, Steel, 36, 55, and 105-ksi Yield Strength

**Three Grades**

**4. Classification**

4.1 The anchor bolts are furnished in three grades denoting minimum yield strength and two classes denoting thread class as follows:

| Grade           | Tensile Strength, ksi (MPa) | Description<br>Yield Strength, min, ksi (MPa) | Size Range, in. (mm) |
|-----------------|-----------------------------|---|----------------------|
| 36 <sup>A</sup> | 58–80 (400–558)             | 36 (248)                                      | ¼–4 (6.4–102)        |
| 55              | 75–95 (517–655)             | 55 (380)                                      | ¼–4 (6.4–102)        |
| 105             | 125–150 (862–1034)          | 105 (724)                                     | ¼–3 (6.4–76)         |

Class  
1A anchor bolts with Class 1A threads  
2A anchor bolts with Class 2A threads

<sup>A</sup> When Grade 36 is specified, a weldable Grade 55 may be furnished at the supplier's option.



197

**ASTM A1554-97a**  
Standard Specification for Anchor Bolts, Steel, 36, 55, and 105-ksi Yield Strength

4.2 Weldable steel for Grade 55 is provided for in Supplementary Requirement S1.



198

**ASTM A1554-97a**  
Standard Specification for Anchor Bolts, Steel, 36, 55, and 105-ksi Yield Strength

**Substitution option: weldable Grade 55 for Grade 36**

**4. Classification**

4.1 The anchor bolts are furnished in three grades denoting minimum yield strength and two classes denoting thread class as follows:

| Grade           | Tensile Strength, ksi (MPa) | Description<br>Yield Strength, min, ksi (MPa) | Size Range, in. (mm) |
|-----------------|-----------------------------|---|----------------------|
| 36 <sup>A</sup> | 58–80 (400–558)             | 36 (248)                                      | ¼–4 (6.4–102)        |
| 55              | 75–95 (517–655)             | 55 (380)                                      | ¼–4 (6.4–102)        |
| 105             | 125–150 (862–1034)          | 105 (724)                                     | ¼–3 (6.4–76)         |

Class  
1A anchor bolts with Class 1A threads  
2A anchor bolts with Class 2A threads

<sup>A</sup> When Grade 36 is specified, a weldable Grade 55 may be furnished at the supplier's option.



199

**ASTM A1554-97a**  
Standard Specification for Anchor Bolts, Steel, 36, 55, and 105-ksi Yield Strength

| Permitted Options |             |
|-------------------|-------------|
| Ordered           | Delivered   |
| Grade 36          | Grade 36    |
|                   | Grade 55 S1 |
| Grade 55          | Grade 55    |
|                   | Grade 55 S1 |
| Grade 55 S1       | Grade 55 S1 |
| Grade 105         | Grade 105   |



**ASTM A1554-97a**  
Standard Specification for Anchor Bolts, Steel, 36, 55, and 105-ksi Yield Strength

| Permitted Options |             |
|-------------------|-------------|
| Ordered           | Delivered   |
| Grade 36          | Grade 36    |
|                   | Grade 55 S1 |
| Grade 55          | Grade 55    |
|                   | Grade 55 S1 |
| Grade 55 S1       | Grade 55 S1 |
| Grade 105         | Grade 105   |

Four Types to be Considered

**ASTM A1554-97a**  
Standard Specification for Anchor Bolts, Steel, 36, 55, and 105-ksi Yield Strength

**TABLE 1 Chemical Requirements for Grade 36**

| Element                         | Diameter, in. (mm) |                               |                                |
|---------------------------------|--------------------|-------------------------------|--------------------------------|
|                                 | To ¾ (20), incl    | Over ¾ to 1½ (20 to 40), incl | Over 1½ to 4 (40 to 100), incl |
| Carbon, max, %                  |                    |                               |                                |
| Heat                            | 0.26               | 0.27                          | 0.28                           |
| Product                         | 0.29               | 0.30                          | 0.31                           |
| Manganese, %                    |                    |                               |                                |
| Heat                            | 0.60–0.90          | 0.60–0.90                     | 0.60–0.90                      |
| Product                         | 0.54–0.98          | 0.54–0.98                     | 0.54–0.98                      |
| Phosphorus, max, %              |                    |                               |                                |
| Heat                            | 0.04               | 0.04                          | 0.04                           |
| Product                         | 0.05               | 0.05                          | 0.05                           |
| Sulfur, max, %                  |                    |                               |                                |
| Heat                            | 0.05               | 0.05                          | 0.05                           |
| Product                         | 0.06               | 0.06                          | 0.06                           |
| Copper, min, % (when specified) |                    |                               |                                |
| Heat                            | 0.20               | 0.20                          | 0.20                           |
| Product                         | 0.18               | 0.18                          | 0.18                           |

<sup>A</sup> Optional with the manufacturer but shall be compatible with weldable steel.

Similar to A36

**ASTM A1554-97a**  
Standard Specification for Anchor Bolts, Steel, 36, 55, and 105-ksi Yield Strength

**TABLE 2 Chemical Requirements for Grades 55 and 105**

| Element                            | Composition, % |                  |
|------------------------------------|----------------|------------------|
|                                    | Heat Analysis  | Product Analysis |
| Grade 55                           |                |                  |
| Grade 105                          |                |                  |
| Phosphorous, max                   | 0.040          | 0.048            |
| Sulfur, max                        | 0.050          | 0.058            |
| Copper, min (when Cu is specified) | 0.20           | 0.18             |

No controls on carbon or alloy content

**ASTM A1554-97a**  
Standard Specification for Anchor Bolts, Steel, 36, 55, and 105-ksi Yield Strength

**Grade 55 S1**

**S1. Grade 55 Bars and Anchor Bolts**

S1.1 The material described in this section is intended for welding. This supplemental section, by chemical composition restrictions and by a carbon equivalent formula, provides assurance of weldability.

S1.2 Welding technique is of fundamental importance when bolts produced to this supplementary section are welded. It is assumed that suitable welding procedures for the steel being welded and the intended service will be selected.

**ASTM A1554-97a**  
Standard Specification for Anchor Bolts, Steel, 36, 55, and 105-ksi Yield Strength

**Grade 55 S1**

S1.5 Chemical Composition:  
S1.5.1 Steel shall conform to the following limitations:

|                    | Heat Analysis | Product Analysis |
|--------------------|---------------|------------------|
| Carbon, max, %     | 0.30          | 0.33             |
| Manganese, max, %  | 1.35          | 1.41             |
| Phosphorus, max, % | 0.040         | 0.048            |
| Sulfur, max, %     | 0.050         | 0.058            |
| Silicon, max, %    | 0.50          | 0.55             |

→ Carbon, max, %  
→ Manganese, max, %  
→ Phosphorus, max, %  
→ Sulfur, max, %  
→ Silicon, max, %

Cold Cracking Controls

Hot Cracking Controls



**ASTM A1554-97a**  
Standard Specification for Anchor Bolts, Steel, 36, 55, and 105-ksi Yield Strength

**Grade 55 S1**

S1.5.2 Carbon Equivalent—In addition to the requirements specified in S1.5.1, the analysis shall be such as to provide a carbon equivalent (CE) meeting the following requirements:

S1.5.2.1 For alloy or low-alloy steel, the carbon equivalent shall not exceed 0.45 % when calculated as follows:

$$CE = \% C + \frac{\% Mn}{6} + \frac{\% Cu}{40} + \frac{\% Ni}{20} + \frac{\% Cr}{10} + \frac{\% Mo}{50} + \frac{\% V}{10}$$

S1.5.2.2 For carbon steel, the carbon equivalent shall not exceed 0.40 % when calculated as follows:

$$CE = \% C + \frac{\% Mn}{4}$$

**Grade 36**

- Chemistry is similar to that of ASTM A36
- Deviation on Mn permitted only for smaller rods
- If Grade 55 is substituted, only weldable (S1) material may be used

**Weldability should be good.**



**Grade 55**

- The only chemistry control is on S, P (and Cu, when Cu is specified)
- No weldability promises

**Weldability should be investigated on a case-by-case basis.**



208

**Grade 55 S1**

- Chemistry is similar to that of ASTM A36
- Carbon equivalency limits
- “The material described in this section is intended for welding.”
- “This supplemental section...provides assurance of weldability.”

**Weldability should be good.**



209

**Grade 105**

- The only chemistry control is on S, P (and Cu, when Cu is specified)
- No weldability promises
- High strength (105 ksi yield)
- May be quenched and tempered

**Weldability is likely to be poor.**

**Caveat:** poor weldability does not mean unweldable.



210

**PROBLEMS AND FIXES**

**Extending Anchor Rods**

- Secure the column
- Investigate mechanical options
- Investigate weldability
- Use an appropriate detail



211

**PROBLEMS AND FIXES**

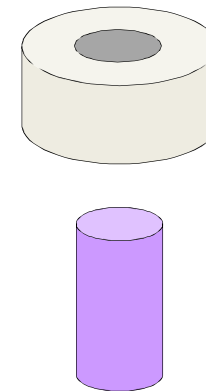

212

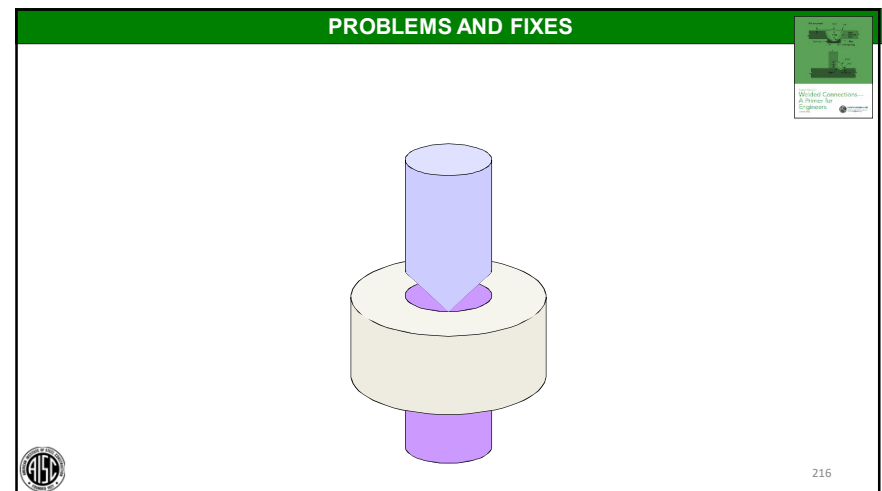
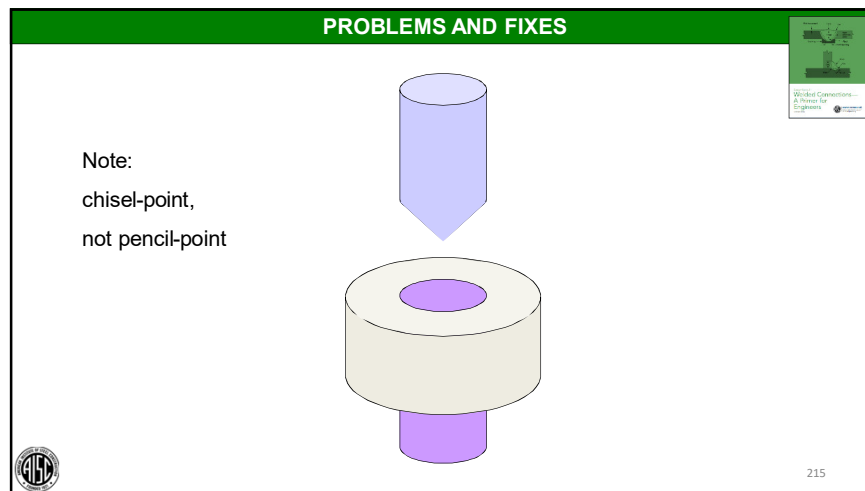
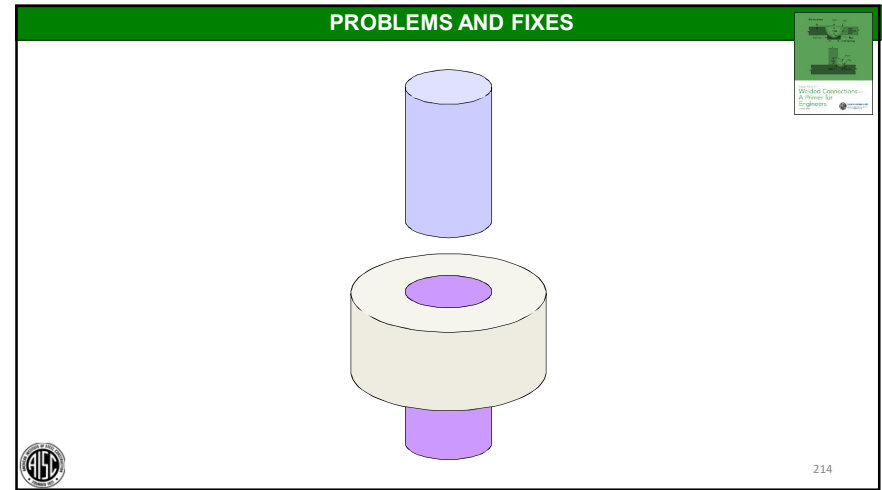
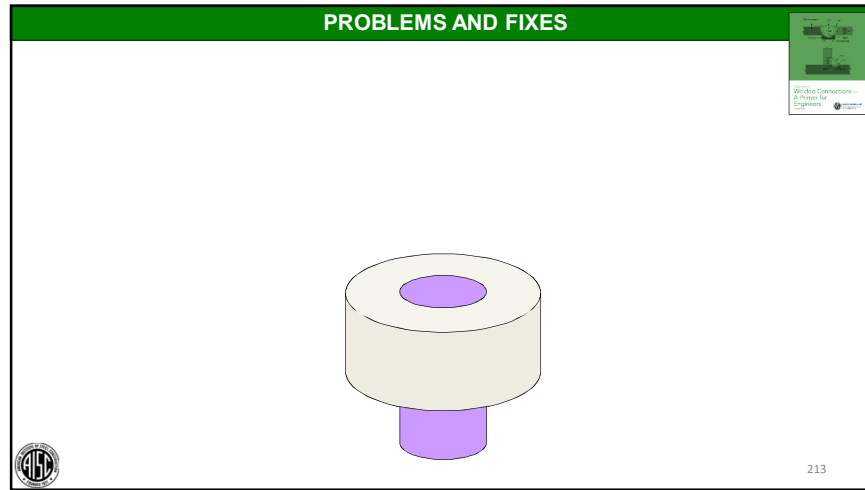

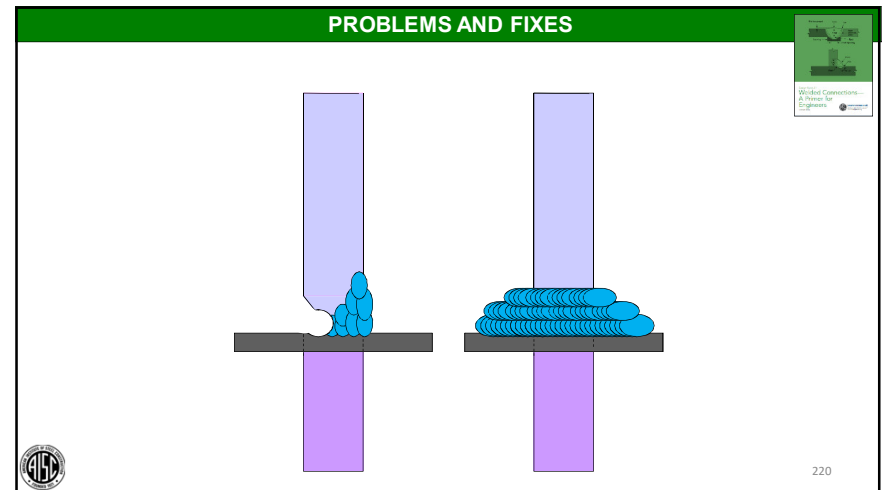
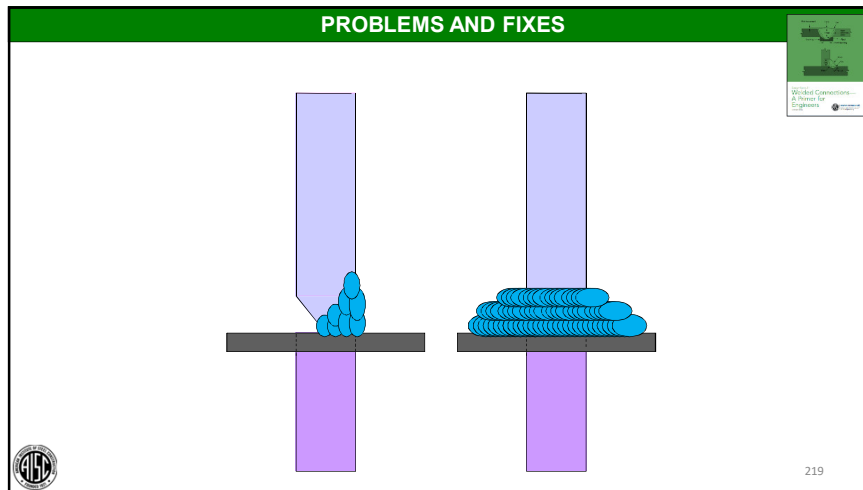
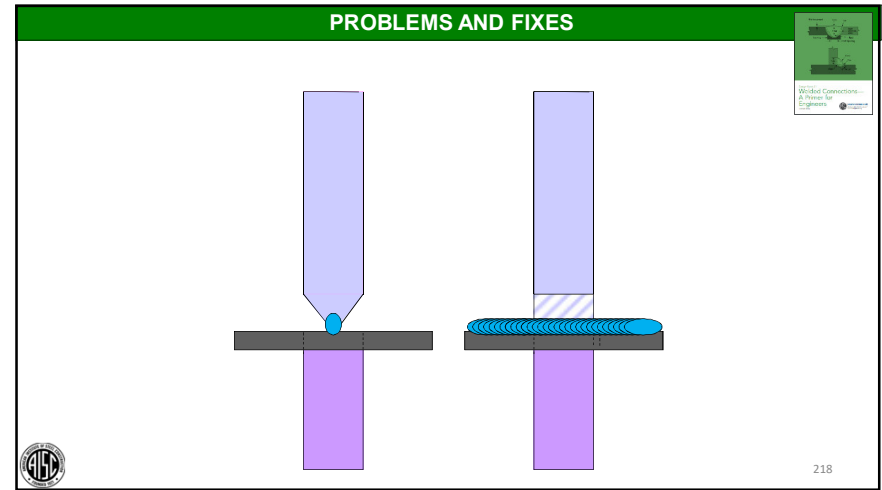
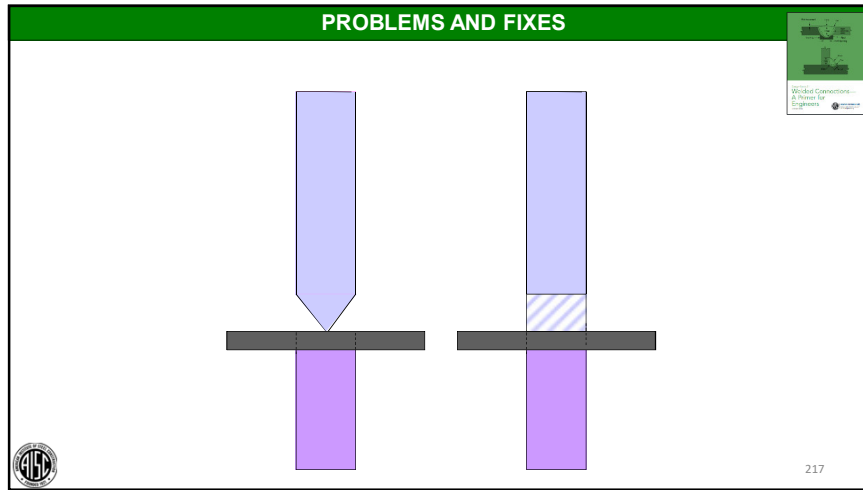

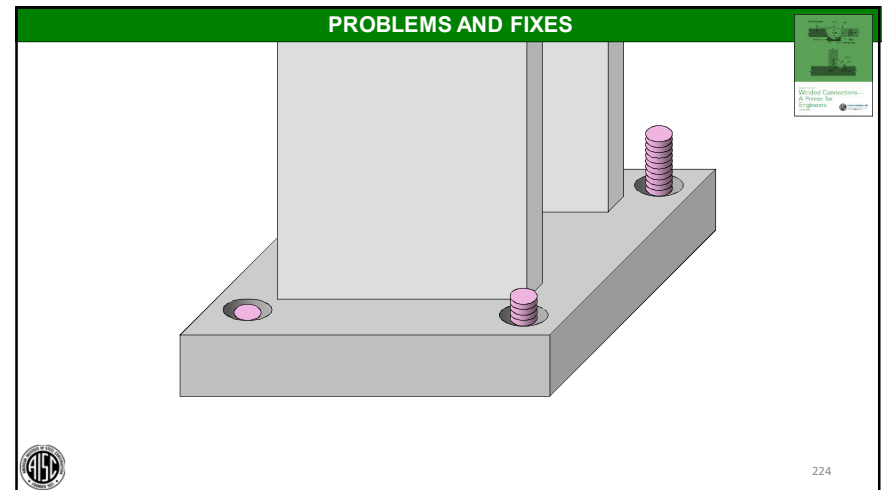
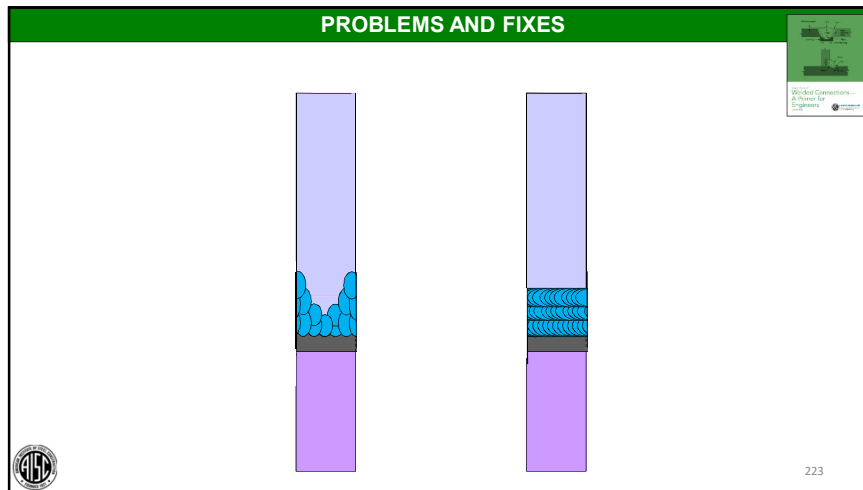
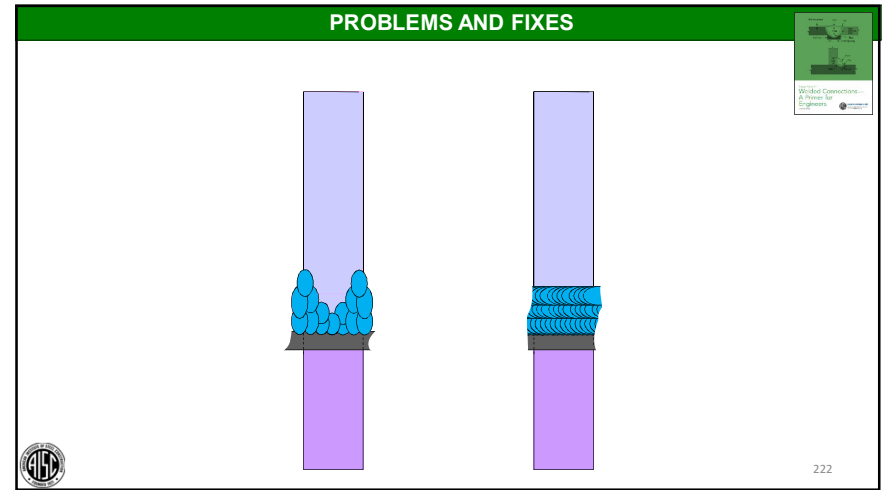
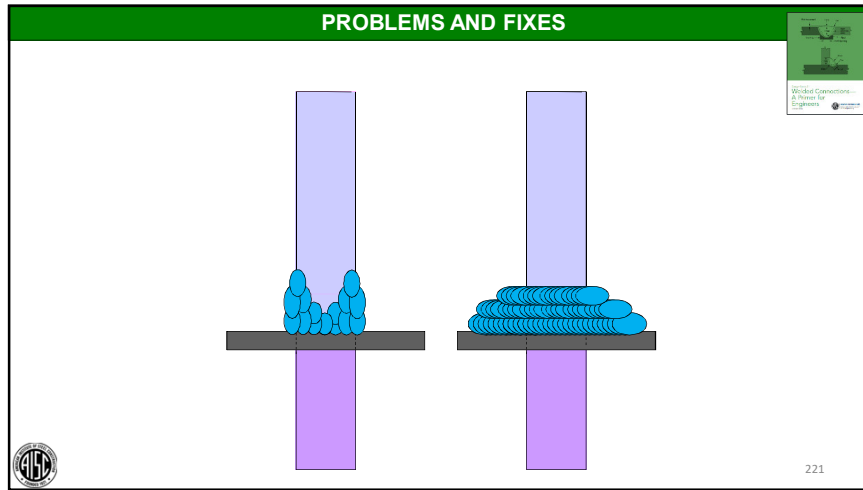

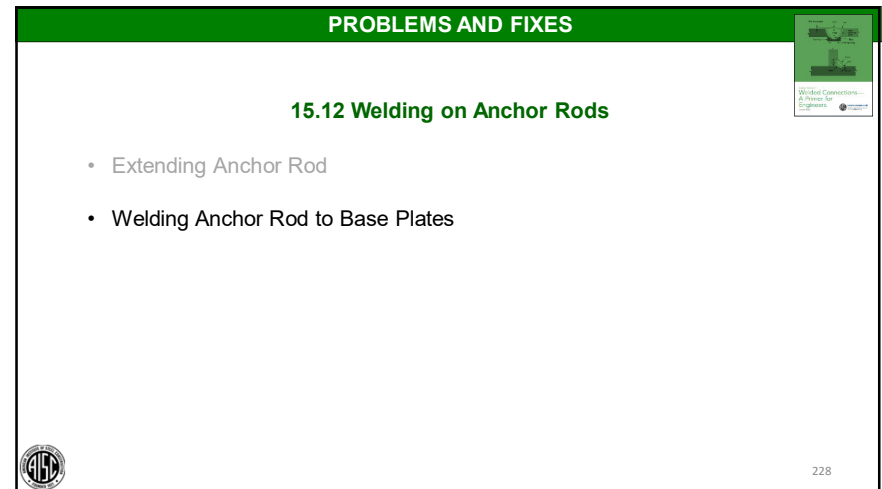
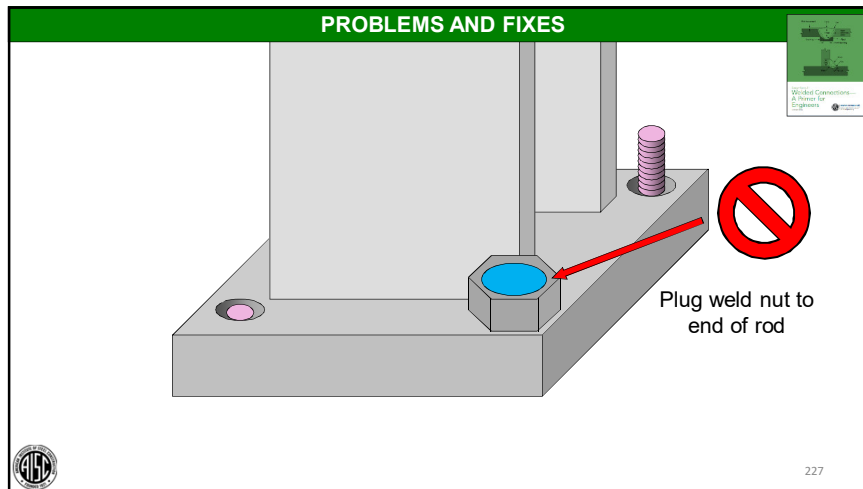
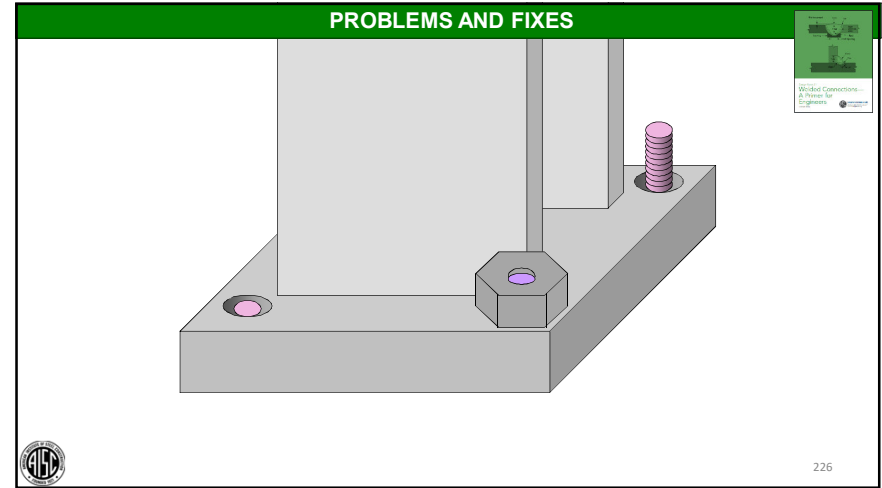
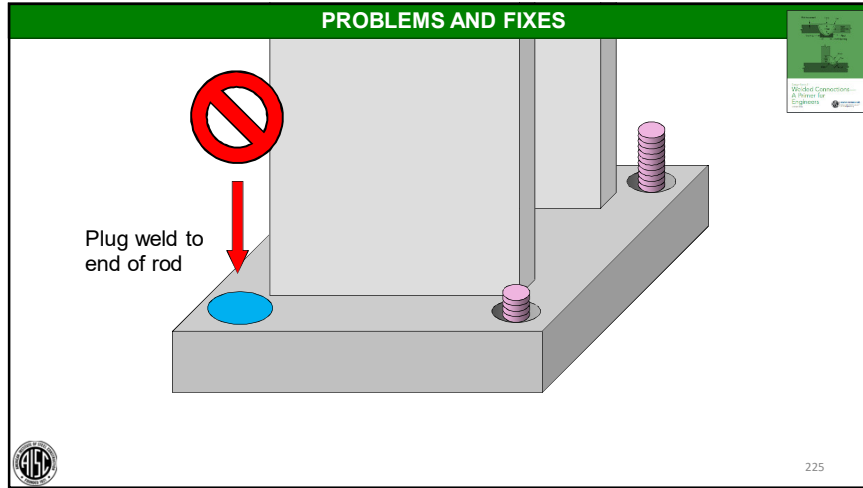

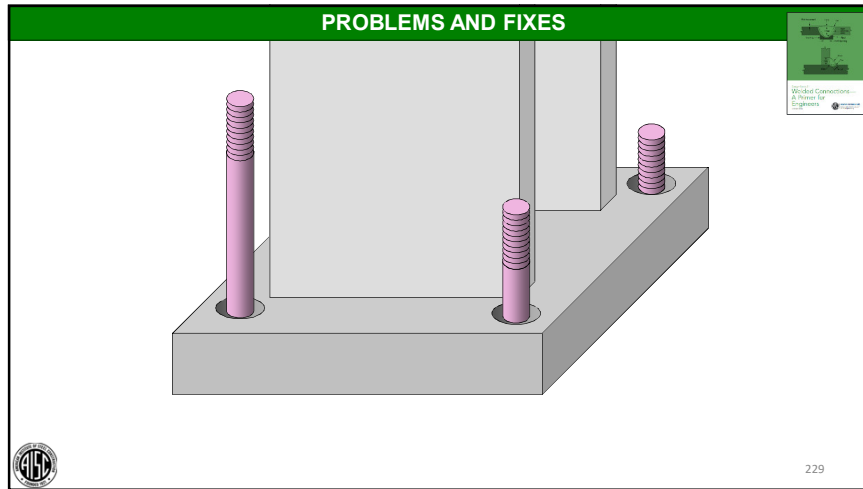

PROBLEMS AND FIXES

### Welding Anchor Rod to Base Plates

- Secure the column
- Is there sufficient anchorage?
- Investigate mechanical options

Welded Connections – A Primer for Engineers

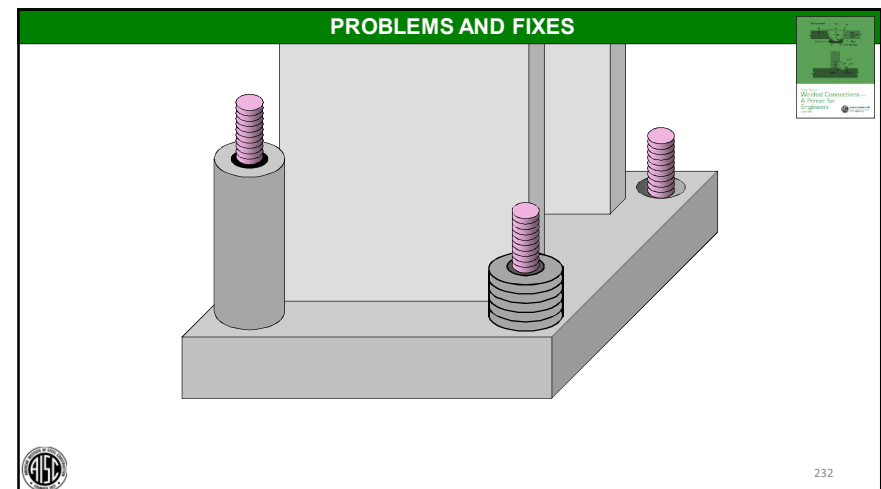
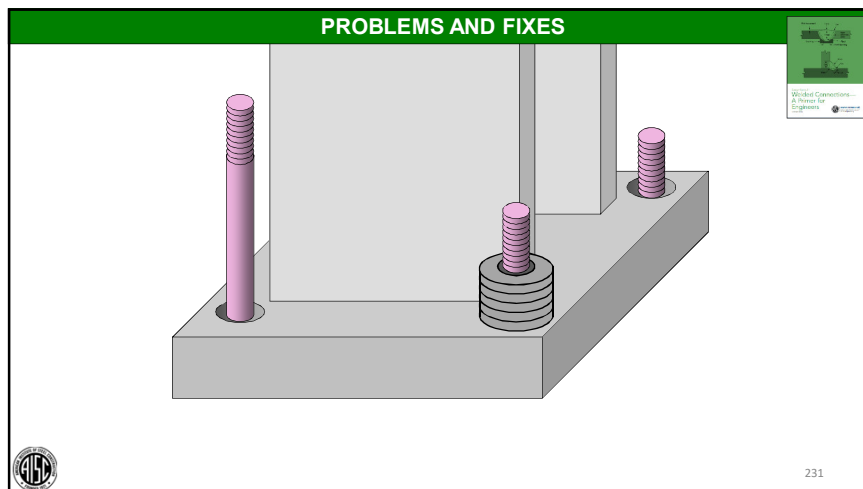

230



**PROBLEMS AND FIXES**

### Welding Anchor Rod to Base Plates



- Secure the column
- Is there sufficient anchorage?
- Investigate mechanical options
- Investigate weldability
- Use an appropriate detail



233

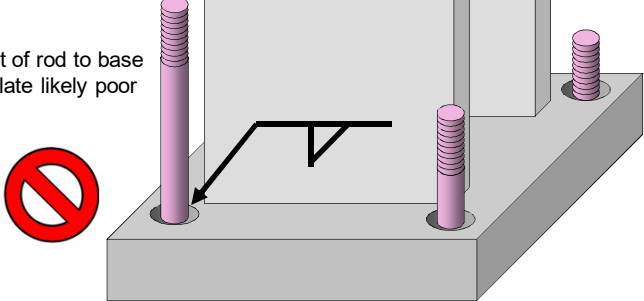

**PROBLEMS AND FIXES**

Fit of rod to base plate likely poor



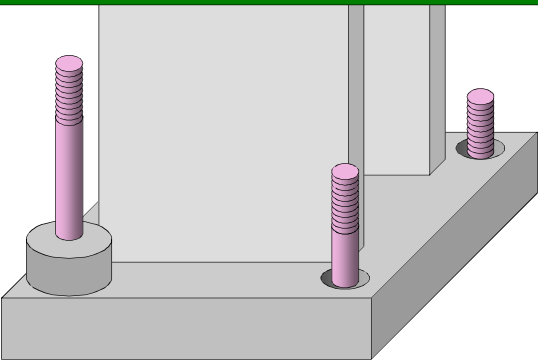

234

**PROBLEMS AND FIXES**



235

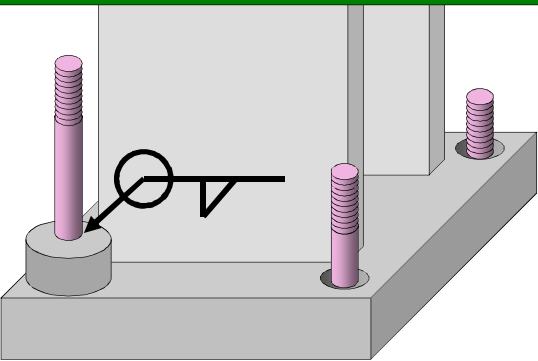

**PROBLEMS AND FIXES**



236

**PROBLEMS AND FIXES**

- 15.9 Heat Shrinking of Q&T Steel
- ➔ 15.10 Unspecified Welds
- 15.11 Welds Made Without Inspection
- 15.12 Welding on Anchor Rods
- 15.13 Welding Anchor Rod to Base Plates
- 15.14 Removing And Reinstalling Column Base Plates
- 15.15 Repairing Lamellar Tears





237

**PROBLEMS AND FIXES**

### Unspecified Welds

Unspecified welds are welds made on a structure that are not identified on contract, shop, or erection drawings.

Tack welds and construction aid welds are separately discussed in AWS D1.1, clause 5.17, with specific provisions for dealing with each type of weld; these are not categorized as unspecified welds.





238

**AWS D1.1:2015 Structural Welding Code--Steel**

### 6.5 Inspection of Work and Records

6.5.1 Size, Length, and Location of Welds.

The Inspector shall ensure that the size, length, and location of all welds conform to the requirements of this code and to the detail drawings and that **no unspecified welds have been added without the approval of the Engineer.**





239

**PROBLEMS AND FIXES**

### Unspecified Welds

The question to be answered: **Why?**

**“When it rains, it pours”**





240

**PROBLEMS AND FIXES**

**Unspecified Welds**

“Additional caution should be given to unspecified welds when the structure is subjected to **cyclic** or **seismic** loading.”



“In most cases, problematic unspecified welds can be removed and the localized area repaired by grinding.”



241

**PROBLEMS AND FIXES**

- 15.9 Heat Shrinking of Q&T Steel
- 15.10 Unspecified Welds
- ➔ 15.11 Welds Made Without Inspection
- 15.12 Welding on Anchor Rods
- 15.13 Welding Anchor Rod to Base Plates
- 15.14 Removing And Reinstalling Column Base Plates
- 15.15 Repairing Lamellar Tears





242

**PROBLEMS AND FIXES**

**Question:**  
The weld was done without the requisite inspection. Do I have it removed and replaced with the inspector present?

**A related theoretical question:**  
Is it possible for a welder to make a good weld if an inspector is not present?





243

**AISC 360:16 Specification for Structural Steel Buildings**

**CHAPTER N**

**QUALITY CONTROL AND QUALITY ASSURANCE**

This chapter addresses **minimum requirements for quality control, quality assurance and nondestructive testing** for structural steel systems and steel elements of composite members for buildings and other structures.



244

**AISC 360:16 Specification for Structural Steel Buildings**

**N5. MINIMUM REQUIREMENTS FOR INSPECTION OF STRUCTURAL STEEL BUILDINGS**

**4. Inspection of Welding**

Observation of welding operations and visual inspection of in-process and completed welds shall be the primary method to confirm that the materials, procedures and workmanship are in conformance with the construction documents.



245

**AISC 360:16 Specification for Structural Steel Buildings**

**N5. MINIMUM REQUIREMENTS FOR INSPECTION OF STRUCTURAL STEEL BUILDINGS**

**4. Inspection of Welding (cont'd)**

As a minimum, welding inspection tasks shall be in accordance with Tables N5.4-1, N5.4-2 and N5.4-3. In these tables, the inspection tasks are as follows:



246

**AISC 360:16 Specification for Structural Steel Buildings**

**N5. MINIMUM REQUIREMENTS FOR INSPECTION OF STRUCTURAL STEEL BUILDINGS**

**4. Inspection of Welding (cont'd)**

(a) Observe (O): The inspector shall observe these items on a random basis. Operations need not be delayed pending these inspections.

(b) Perform (P): These tasks should be performed for each welded joint or member.



247

**AISC 360:16 Specification for Structural Steel Buildings**

**TABLE N5.4-1  
 Inspection Tasks Prior to Welding**

| Inspection Tasks Prior to Welding                             | QC | QA |
|---|----|----|
| Welder qualification records and continuity records           | P  | O  |
| WPS available   | P  | P  |
| Manufacturer certifications for welding consumables available | P  | P  |
| Material identification (type/grade)                          | O  | O  |
| Welder identification system <sup>[a]</sup>                   | O  | O  |



248

**AISC 360:16 Specification for Structural Steel Buildings**

**TABLE N5.4-2  
Inspection Tasks During Welding**

| Inspection Tasks During Welding  | QC | QA |
|--|----|----|
| Control and handling of welding consumables <ul style="list-style-type: none"> <li>• Packaging</li> <li>• Exposure control</li> </ul>          | O  | O  |
| No welding over cracked tack welds   | O  | O  |
| Environmental conditions <ul style="list-style-type: none"> <li>• Wind speed within limits</li> <li>• Precipitation and temperature</li> </ul> | O  | O  |

249

**AISC 360:16 Specification for Structural Steel Buildings**

**TABLE N5.4-3  
Inspection Tasks After Welding**

| Inspection Tasks After Welding  | QC | QA |
|---|----|----|
| Welds cleaned   | O  | O  |
| Size, length and location of welds  | P  | P  |
| Welds meet visual acceptance criteria <ul style="list-style-type: none"> <li>• Crack prohibition</li> <li>• Weld/base-metal fusion</li> <li>• Crater cross section</li> <li>• Weld profiles</li> <li>• Weld size</li> <li>• Undercut</li> </ul> | P  | P  |

250

**AISC 360:16 Specification for Structural Steel Buildings**

**TABLE N5.4-3  
Inspection Tasks After Welding**

| Inspection Tasks After Welding  | QC | QA |
|---|----|----|
| Welds cleaned   | O  | O  |
| Size, length and location of welds  | P  | P  |
| Welds meet visual acceptance criteria <ul style="list-style-type: none"> <li>• Crack prohibition</li> <li>• Weld/base-metal fusion</li> <li>• Crater cross section</li> <li>• Weld profiles</li> <li>• Weld size</li> <li>• Undercut</li> <li>• Porosity</li> </ul> | P  | P  |
| Arc strikes   | P  |    |
| K-area <sup>(1)</sup>   | P  | P  |
| Weld access holes in rolled heavy shapes and built-up heavy shapes <sup>(2)</sup>   | P  | P  |
| Backing removed and weld tabs removed (if required)   | P  | P  |
| Repair activities   | P  | P  |
| Document acceptance or rejection of welded joint or member  | P  | P  |
| No prohibited welds have been added without the approval of the EOR   | O  | O  |

(1) When welding of doubler plates, continuity plates or stiffeners has been performed in the K-area, visually inspect the web K-area for cracks within 3 in. (75 mm) of the weld.  
 (2) After rolled heavy shapes (see Section A3.1c) and built-up heavy shapes (see Section A3.1d) are welded, visually inspect the weld access hole for cracks.

251

All of these inspections can still be performed

**AISC 360:16 Specification for Structural Steel Buildings**

**TABLE N5.4-1  
Inspection Tasks Prior to Welding**

| Inspection Tasks Prior to Welding   | QC | QA |
|---|----|----|
| Welder qualification records and continuity records ✓   | P  | O  |
| WPS available ✓   | P  | P  |
| Manufacturer certifications for welding consumables available ✓   | P  | P  |
| Material Identification (type/grade) ✓  | O  | O  |
| Welder identification system <sup>(1)</sup> ✓   | O  | O  |
| Fit-up of groove welds (including joint geometry) <ul style="list-style-type: none"> <li>• Joint preparations</li> <li>• Dimensions (alignment, root opening, root face, bevel)</li> <li>• Cleanliness (condition of steel surfaces)</li> <li>• Tacking (tack weld quality and location) ✓</li> <li>• Backing type and fit (if applicable) ✓</li> </ul> | O  |    |
| Fit-up of CJP groove welds of HSS T-, Y- and K-joints without backing (including joint geometry) <ul style="list-style-type: none"> <li>• Joint preparations</li> <li>• Dimensions (alignment, root opening, root face, bevel)</li> <li>• Cleanliness (condition of steel surfaces)</li> <li>• Tacking (tack weld quality and location) ✓</li> </ul>    | P  | O  |
| Configuration and finish of access holes ✓  | O  | O  |
| Fit-up of fillet welds <ul style="list-style-type: none"> <li>• Dimensions (alignment, gaps at root)</li> <li>• Cleanliness (condition of steel surfaces)</li> <li>• Tacking (tack weld quality and location)</li> </ul>  | O  | O  |
| Check welding equipment ✓   | O  | -  |

(1) The fabricator or erector, as applicable, shall maintain a system by which a welder who has welded a joint or member can be identified. Stamps, if used, shall be the low-stress type.

252

Some of these inspections can still be performed

**AISC 360:16 Specification for Structural Steel Buildings**

**TABLE N5.4-2  
Inspection Tasks During Welding**

| Inspection Tasks During Welding  | QC | QA |
|--|----|----|
| Control and handling of welding consumables <ul style="list-style-type: none"> <li>• Packaging ✓</li> <li>• Exposure control</li> </ul>  | O  | O  |
| No welding over cracked tack welds   | O  | O  |
| Environmental conditions <ul style="list-style-type: none"> <li>• Wind speed within limits</li> <li>• Precipitation and temperature</li> </ul>   | O  | O  |
| WPS followed <ul style="list-style-type: none"> <li>• Settings on welding equipment</li> <li>• Travel speed</li> <li>• Selected welding materials ✓</li> <li>• Shielding gas type/flow rate</li> <li>• Preheat applied</li> <li>• Interpass temperature maintained (min./max.)</li> <li>• Proper position (F, V, H, OH)</li> </ul> | O  | O  |
| Welding techniques <ul style="list-style-type: none"> <li>• Interpass and final cleaning</li> <li>• Each pass within profile limitations</li> <li>• Each pass meets quality requirements</li> </ul>  | O  | O  |
| Placement and installation of steel headed stud anchors ✓  | P  | P  |

*Some of these inspections can still be performed*

253

**AISC 360:16 Specification for Structural Steel Buildings**

**TABLE N5.4-1  
Inspection Tasks Prior to Welding**

| Inspection Tasks Prior to Welding   | QC | QA |
|---|----|----|
| Welder qualification records and continuity records   | P  | O  |
| WPS available   | P  | P  |
| Manufacturer certifications for welding consumables available   | P  | P  |
| Material identification (type/grade)  | O  | O  |
| Welder identification system <sup>24</sup>  | O  | O  |
| Fit-up of groove welds (including joint geometry) <ul style="list-style-type: none"> <li>• Joint preparations</li> <li>• Dimensions (alignment, root opening, root face, bevel)</li> <li>• Cleanliness (condition of steel surfaces)</li> <li>• Tacking (tack weld quality and location)</li> <li>• Backing type and fit (if applicable)</li> </ul> | O  | O  |
| Fit-up of CJP groove welds of HSS T, Y- and K-joints without backing (including joint geometry) <ul style="list-style-type: none"> <li>• Joint preparations</li> <li>• Dimensions (alignment, root opening, root face, bevel)</li> <li>• Cleanliness (condition of steel surfaces)</li> <li>• Tacking (tack weld quality and location)</li> </ul>   | P  | O  |
| Configuration and finish of access holes  | O  | O  |
| Fit-up of fillet welds <ul style="list-style-type: none"> <li>• Dimensions (alignment, gaps at root)</li> <li>• Cleanliness (condition of steel surfaces)</li> <li>• Tacking (tack weld quality and location)</li> </ul>  | O  | O  |
| Check welding equipment   | O  | -- |

*Only two "P" tasks, and those can be done after welding is completed.*

<sup>24</sup> The fabricator or erector, as applicable, shall maintain a system by which a welder who has welded a joint or member can be identified. Stamps, if used, shall be the low-stress type.

254

**AISC 360:16 Specification for Structural Steel Buildings**

**TABLE N5.4-2  
Inspection Tasks During Welding**

| Inspection Tasks During Welding  | QC | QA |
|--|----|----|
| Control and handling of welding consumables <ul style="list-style-type: none"> <li>• Packaging</li> <li>• Exposure control</li> </ul>  | O  | O  |
| No welding over cracked tack welds   | O  | O  |
| Environmental conditions <ul style="list-style-type: none"> <li>• Wind speed within limits</li> <li>• Precipitation and temperature</li> </ul>   | O  | O  |
| WPS followed <ul style="list-style-type: none"> <li>• Settings on welding equipment</li> <li>• Travel speed</li> <li>• Selected welding materials</li> <li>• Shielding gas type/flow rate</li> <li>• Preheat applied</li> <li>• Interpass temperature maintained (min./max.)</li> <li>• Proper position (F, V, H, OH)</li> </ul> | O  | O  |
| Welding techniques <ul style="list-style-type: none"> <li>• Interpass and final cleaning</li> <li>• Each pass within profile limitations</li> <li>• Each pass meets quality requirements</li> </ul>  | O  | O  |
| Placement and installation of steel headed stud anchors  | P  | P  |

*No "p" tasks (except for studs)*

255

**PROBLEMS AND FIXES**

**Question:**  
The weld was done without the requisite inspection. Do I have it removed and replaced with the inspector present?

**Questions that should be asked?**

- Do the welds meet the visual acceptance criteria?
- Has anything changed?
- Does it pass the smell test?



256



**PROBLEMS AND FIXES**

**Question:**  
The weld was done without the requisite inspection. Do I have it removed and replaced with the inspector present?

**Possible answers:**  
No, providing a careful review of the situation reveals no significant non-conformances.  
Yes, if the review reveals defective welds.



258

**PROBLEMS AND FIXES**



259

**Thank you!**

AISC | Questions?



Smarter.  
Stronger.  
Steel.

## Individual Session Registrants

### PDH Certificates

- You will receive an email on how to report attendance from: [registration@aisc.org](mailto:registration@aisc.org).
- Be on the lookout: Check your spam filter! Check your junk folder!
- Completely fill out online form. Don't forget to check the boxes next to each attendee's name!



## Individual Session Registrants

### PDH Certificates

- Reporting site (URL will be provided in the forthcoming email).
- Username: Same as AISC website username.
- Password: Same as AISC website password.



## 8-Session Registrants

### PDH Certificates

One certificate will be issued at the conclusion of all 8 sessions.



## 8-Session Registrants

### PDH Certificates

One certificate will be issued at the conclusion of all 8 sessions.

**Certificates will be sent out on January 10, 2019.**



## 8-Session Registrants

### Access to the quiz

Information for accessing the quiz will be emailed to you by Thursday. It will contain a link to access the quiz. EMAIL COMES FROM [NIGHTSCHOOL@AISC.ORG](mailto:NIGHTSCHOOL@AISC.ORG).

### Quiz and attendance records

Posted Thursday mornings. [www.aisc.org/nightschool](http://www.aisc.org/nightschool) -- Click on Current Course Details.

### Reasons for quiz

- EEU – You must take all quizzes and the final exam to receive EEU.
- PDHs – If you watch a recorded session, you must pass quiz for PDHs.
- REINFORCEMENT – Reinforce what you learn tonight. Get more out of the course.

*Note: If you attend the live presentation, you do not have to take the quizzes to receive PDHs*



## 8-Session Registrants

### Access to the recording

Information for accessing the recording will be emailed to you by Thursday. The recording will be available for four weeks. (For 8-session registrants only.) EMAIL COMES FROM [NIGHTSCHOOL@AISC.ORG](mailto:NIGHTSCHOOL@AISC.ORG).

### PDHs via recording

If you watch a recorded session, you must take *and pass* the quiz for PDHs.



## 8-Session Registrants

### Night School Resources

Find all your handouts, quizzes and quiz scores, recording access, and attendance information all in one place!



## 8-Session Registrants

### Night School Resources

Go to [www.aisc.org](http://www.aisc.org) and sign in.



#### Login

If you're an existing customer, please enter your username and password.

**USERNAME**  
Enter your username

**PASSWORD**  
Enter your password

Remember Me

#### DON'T HAVE AN ACCOUNT?

My AISC allows you to access Engineering Journal articles and Design Guides you have downloaded from the bookstores.

[REGISTER NOW](#)



## 8-Session Registrants

### Night School Resources

Go to [www.aisc.org](http://www.aisc.org) and sign in.

**IN THIS SECTION**

- Edit Profile
- My Downloads
- My Pending Quizzes
- My Events
- Order History
- Course History
- Course Resources**

**MyAISC**

**MY PROFILE**  
Update your contact and address information.  
[EDIT PROFILE](#)

**MY PURCHASED DOWNLOADS**  
Access articles and documents that you have purchased.  
[VIEW DOWNLOADS](#)

**MY COURSE RESOURCES**  
View online resources for Night School and Live Webinar package registrations.  
[VIEW RESOURCES](#)



**Smarter. Stronger. Steel.**

## 8-Session Registrants

### Night School Resources

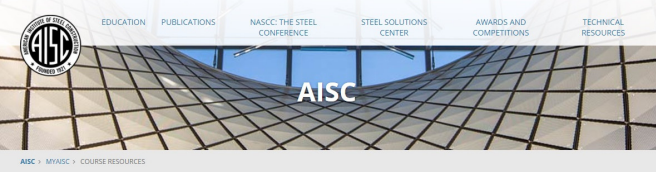

Course Resources

| Event  | Start Date           |
|--|----------------------|
| NS 13 8-Session Package-Night School 13 - Design of Industrial Buildings | 1/30/2017 7:00:00 PM |
| NS 14 8-Session Package-Night School 14 - Fundamentals of Stability      | 6/5/2017 7:00:00 PM  |



**Smarter. Stronger. Steel.**

## 8-Session Registrants

### Night School Resources



Night School 13: Design of Industrial Buildings

**8-SESSION PACKAGE RESOURCES**

| Event  | Date                 | Handouts | Videos                       | Quiz                         | Attendance |
|--|----------------------|----------|------------------------------|------------------------------|------------|
| NS13 - Design Criteria                                     | 1/30/2017 7:00:00 PM | Download | Video                        | Pass Score: 80               | Pending    |
| NS13 - Economic Considerations                             | 2/4/2017 7:00:00 PM  | Download | Available 02/08/2017 5pm EST | Available 02/08/2017 5pm EST | Pending    |
| NS13 - Lateral Load Systems and Details                    | 2/15/2017 7:00:00 PM | Download | Available 02/15/2017 5pm EST | Available 02/15/2017 5pm EST | Pending    |
| NS13 - Preliminary Design Procedures                       | 2/27/2017 7:00:00 PM | Download | Available 03/05/2017 5pm EST | Available 03/05/2017 5pm EST | Pending    |
| NS13 - Crane Girder Design and Frame Analysis              | 3/6/2017 7:00:00 PM  | Download | Available 03/06/2017 5pm EST | Available 03/06/2017 5pm EST | Pending    |
| NS13 - Frame Member and Connection Design                  | 3/13/2017 7:00:00 PM | Download | Available 03/15/2017 5pm EST | Available 03/15/2017 5pm EST | Pending    |
| NS13 - Transfer Crane Girder & Longitudinal Bracing Design | 3/27/2017 7:00:00 PM | Download | Available 03/28/2017 5pm EST | Available 03/29/2017 5pm EST | Pending    |



**Smarter. Stronger. Steel.**

## 8-Session Registrants

### Night School Resources

- Weekly “quiz and recording” email.
- Weekly updates of the master quiz and attendance record, found at [www.aisc.org/nightschool21](http://www.aisc.org/nightschool21). Scroll down to Quiz and Attendance records.
  - Updated on Thursday mornings.



**Smarter. Stronger. Steel.**

## 8-Session Registrants

### Night School Resources

- Webinar connection information
  - Reminder email sent out Tuesday mornings
- Links to handouts also found here



AISC | Thank you

