

AISC Night School

Thank you for joining our live webinar today.
We will begin shortly. Please standby.

**Fundamentals of earthquake engineering
for building structures**

Session 7: Building Configuration
March 29, 2021 | Rafael Sabelli

**Smarter.
Stronger.
Steel.**

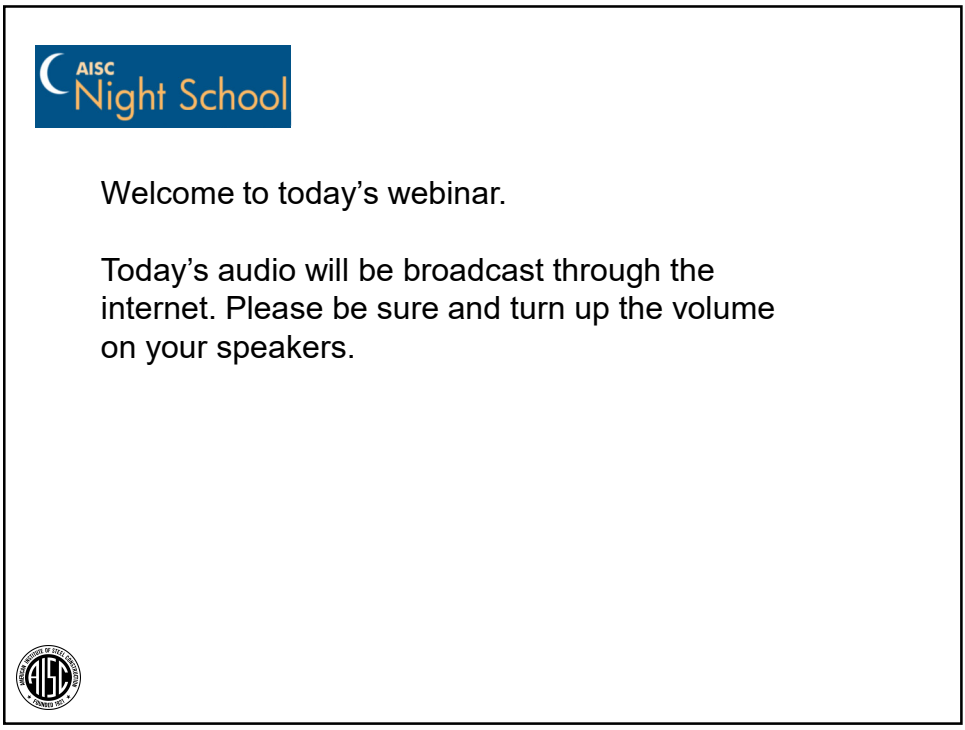

AISC Night School

Welcome to today's webinar.

Today's audio will be broadcast through the internet. Please be sure and turn up the volume on your speakers.





Today's live webinar will begin shortly.
Please standby.

Today's audio will be broadcast through the internet.

Please type any questions or comments through the
Q and A window on your screen.



AIA Credit

AISC is a Registered Provider with The American Institute of Architects Continuing Education Systems (AIA/CES). Credit(s) earned on completion of this program will be reported to AIA/CES for AIA members. Certificates of Completion for both AIA members and non-AIA members are available upon request.

This program is registered with AIA/CES for continuing professional education. As such, it does not include content that may be deemed or construed to be an approval or endorsement by the AIA of any material of construction or any method or manner of handling, using, distributing, or dealing in any material or product.

Questions related to specific materials, methods, and services will be addressed at the conclusion of this presentation.





Copyright Materials

This presentation is protected by US and International Copyright laws. Reproduction, distribution, display and use of the presentation without written permission of AISC is prohibited.

© The American Institute of Steel Construction 2021



Course Description

Building Configuration

March 29, 2021

This Building Configuration lecture will focus on load path and the role and components of diaphragms. There will be a discussion of foundation issues. Irregularities and their treatment in steel frame design will be covered. The session will present the treatment of 3-dimensional analysis issues as well as of modal-response-spectrum analysis issues. The concept of deformation compatibility will be presented. This lecture will also include a discussion of issues related to fixity and rotation demand.





Learning Objectives

- Describe how load path in a building connects point of contact to the point of resistance.
- List potential load path issues in seismic design.
- Describe foundation seismic design for both shallow and deep foundations.
- Explain the role of diaphragms in the load path of buildings.



Night School 25:
**Fundamentals of earthquake
engineering for building structures**

Rafael Sabelli, SE
Walter P Moore

The circular logo of the American Institute of Steel Construction (AISC).

**Smarter.
Stronger.
Steel.**

The slide features a background image of a man in a purple shirt standing in front of a large industrial machine, likely a steel mill. The text is overlaid on the right side of the image.

Course outline

1. Seismology and earthquake effects
2. Dynamics and response
3. Building dynamics and response
4. Steel behavior
5. System ductility and seismic design
6. Steel systems
7. **Building configuration**
8. Building codes



9

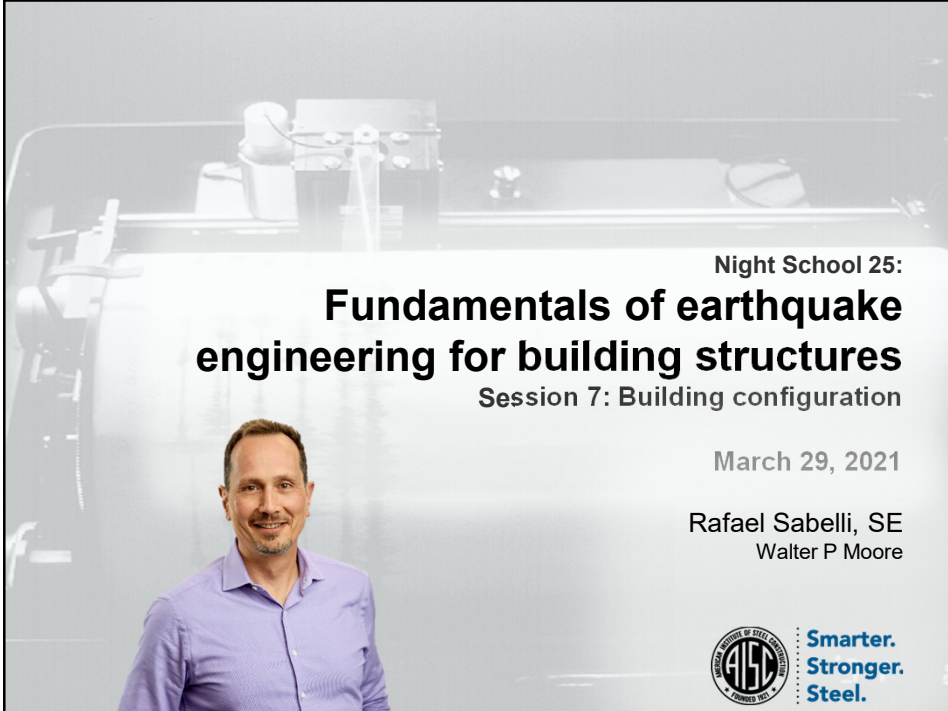

Night School 25:
**Fundamentals of earthquake
engineering for building structures**
Session 7: Building configuration

March 29, 2021

Rafael Sabelli, SE
Walter P Moore



**Smarter.
Stronger.
Steel.**

Session topics

- Load path
- Foundations
- Diaphragms
- Collectors
- Deformation compatibility



11



Load path

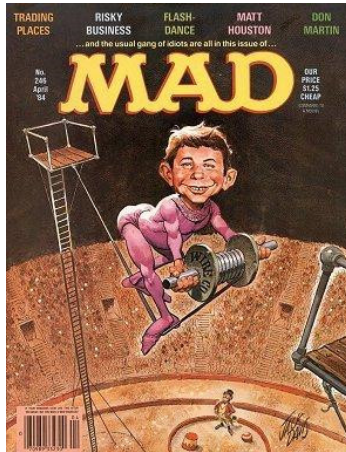

- Connects “point of application” to “point of resistance”
- In seismic design, every element with mass is considered a point of application
- Foundation is considered point of resistance



13

Load path

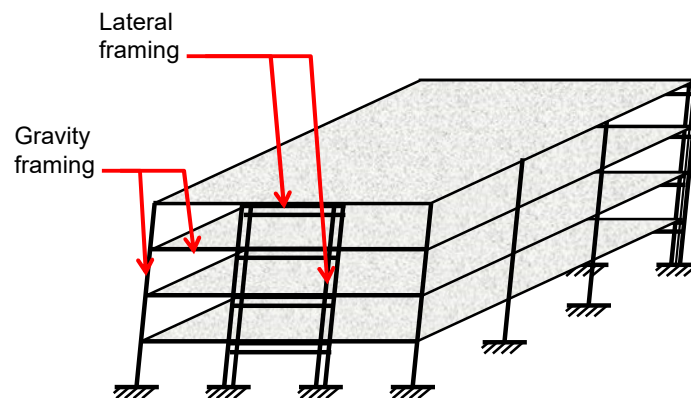

14

Wind vs. seismic loads

- Wind loads
 - External
 - Exposed areas participate
- Seismic loads
 - Inertial
 - All mass participates
- Load path required between mass and foundation



15

Wind load path

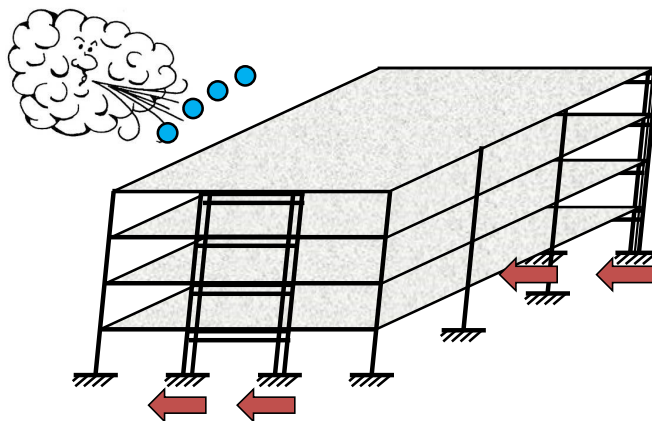

16

Seismic load path

Mass without connection to structure:
No load path

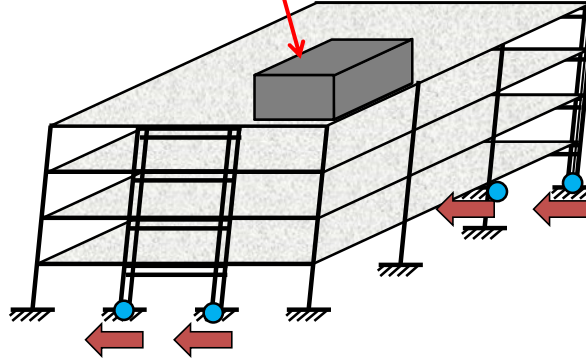

17

Seismic load path

- All masses must have positive connection to seismic-load-resisting system
- Magnitude of connection force due to
 - Ground motion
 - Mass of item
 - Building dynamics (local acceleration)
- Diaphragms contain the majority of typical building mass



18

Seismic-load-resisting system

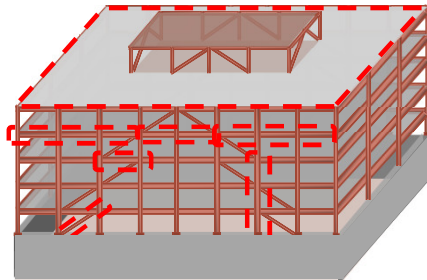

- Vertical frames
 - Beams
 - Columns
 - Braces (if any)
- Diaphragms
 - Deck
 - Chords
 - Collectors
- Foundations



19

Load path issues

- Continuity
 - Load path must be continuous between mass and foundation

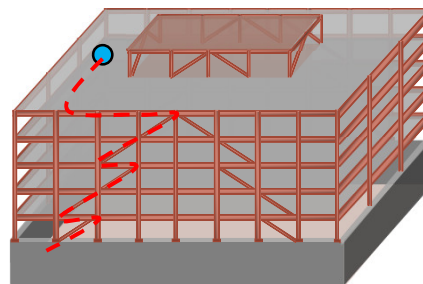

20

Load path issues

- Eccentricity
 - Horizontal eccentricity between mass and frame causes flexure in diaphragm
 - Vertical eccentricity between mass and foundation causes overturning in frame

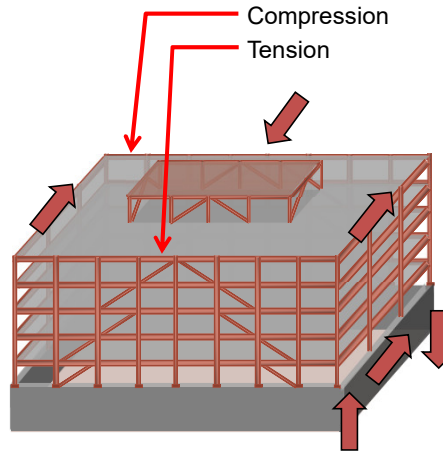

21

Load path issues

- Change in direction
 - At a change in direction load path there is an additional force
 - Vertical
 - Overturning

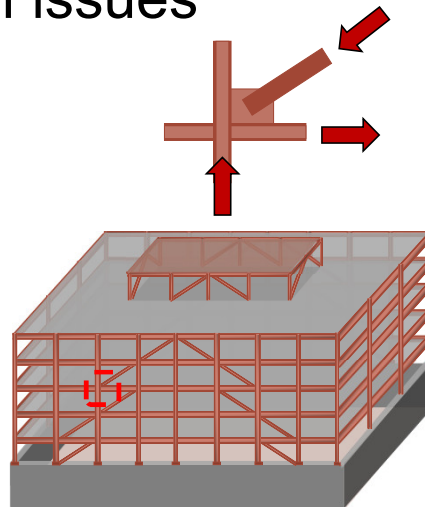

22



Foundations

- Shallow foundations
 - Support
 - Lateral resistance
 - Stability
- Deep foundations
 - Support
 - Lateral resistance
 - Stability



Shallow foundations: support

- Overturning at frames
 - Bearing pressure
 - Short-duration increase in resistance
 - Idealized as triangular
 - Or modeled with soil springs
 - No tension!

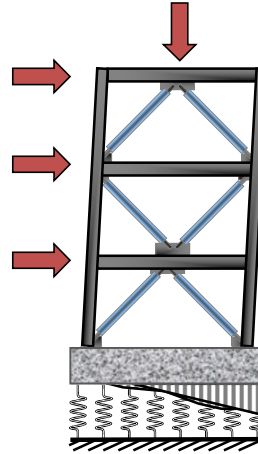

25

Shallow foundations: lateral resistance

- Lateral resistance
 - “Sliding”
 - Friction
 - Bearing (passive pressure)
 - Engagement of multiple footings

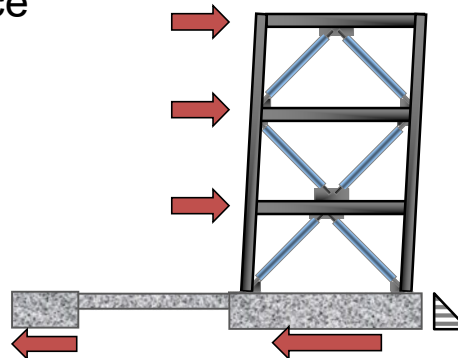

26

Shallow foundations: lateral resistance

- Lateral resistance
 - “Sliding”
 - Friction
 - Bearing (passive pressure)
 - Engagement of multiple footings
 - Relative lateral movement of footings can be problematic

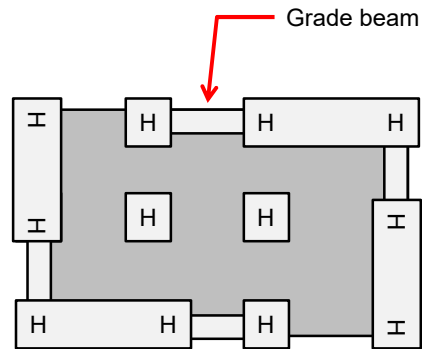

27

Shallow foundations: stability

- May be governing consideration for foundation
- Nonlinear
 - May be stable under ASD and unstable under LRFD loads
 - Minimum requirement: Evaluate under ASD
 - Design footings for soil capacity (amplified)

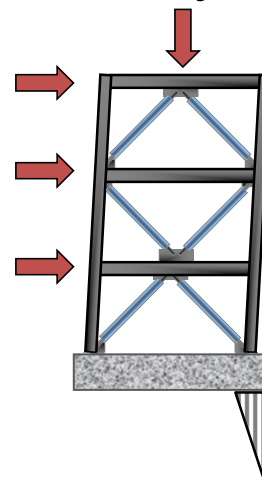

28

Shallow foundations: stability

- Implications of designing for stability with reduced ($1/R$) loads
 - Rocking may be governing mode
 - System above may have lower ductility demand
 - Displacements may be larger than anticipated

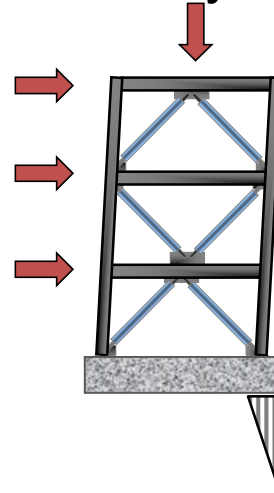

29

Deep foundations: support

- Overturning at frames
 - Compression
 - End bearing
 - Friction
 - Tension
 - Friction
 - Short-duration increases

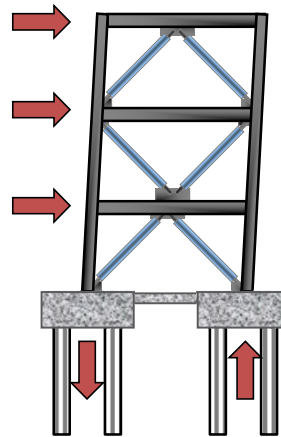

30

Deep foundations: lateral resistance

- Lateral resistance
 - Pile shear and bending
 - Pile-cap bearing (passive pressure)
 - Engagement of multiple footings
 - Batter piles

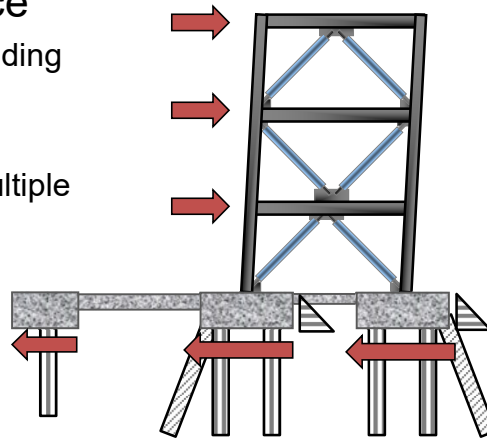

31

Deep foundations: lateral resistance

- Lateral resistance
 - Pile shear and bending
 - Pile-cap bearing (passive pressure)
 - Engagement of multiple footings
 - Buildings tied together
 - Engage all piles
 - Prevent relative movement

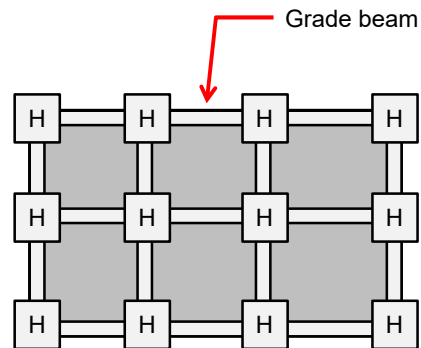

32

Deep foundations: stability

- Stability
 - Addressed by strength design of piles
 - Upper-bound soil strength difficult to establish
 - Rocking mechanism not applicable

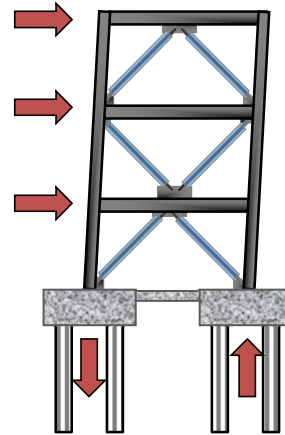

33

Diaphragms



Smarter.
Stronger.
Steel.

Steel Deck (AKA “Metal Deck”)

Shear load path through steel deck and fasteners.

Steel chords and collectors.



35

Deck and Fill

Shear load path through steel deck and fasteners.

Concrete stiffens deck and prevents buckling.

Steel chords and collectors.



36

Steel deck with reinforced concrete fill

Shear load path through reinforced concrete and shear studs.

Chords and collectors:
Steel members, or
Reinforcement in deck

Shear studs.

Reinforcement



37

Horizontal truss diaphragm

Shear load path through steel diagonals and framing.

Steel chords and collectors.

Deck is for gravity only

Truss



38

Diaphragms

- Roles of Diaphragms
- Diaphragm Components
- Diaphragm Behavior and Design Principles
- Building Analysis and Diaphragm Forces
- Diaphragm Analysis and Internal Component Forces



39

Roles of diaphragms

- Support gravity
- Deliver forces to frames
- Brace columns for stability
- Transfer forces between frames
- Resist P- Δ thrust

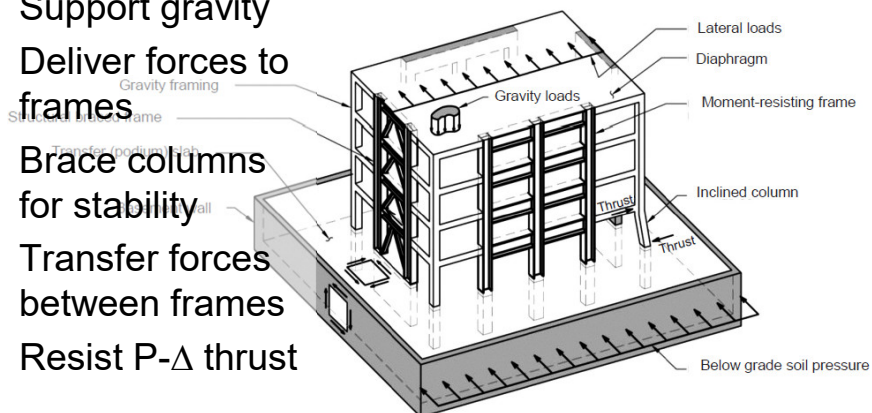

40

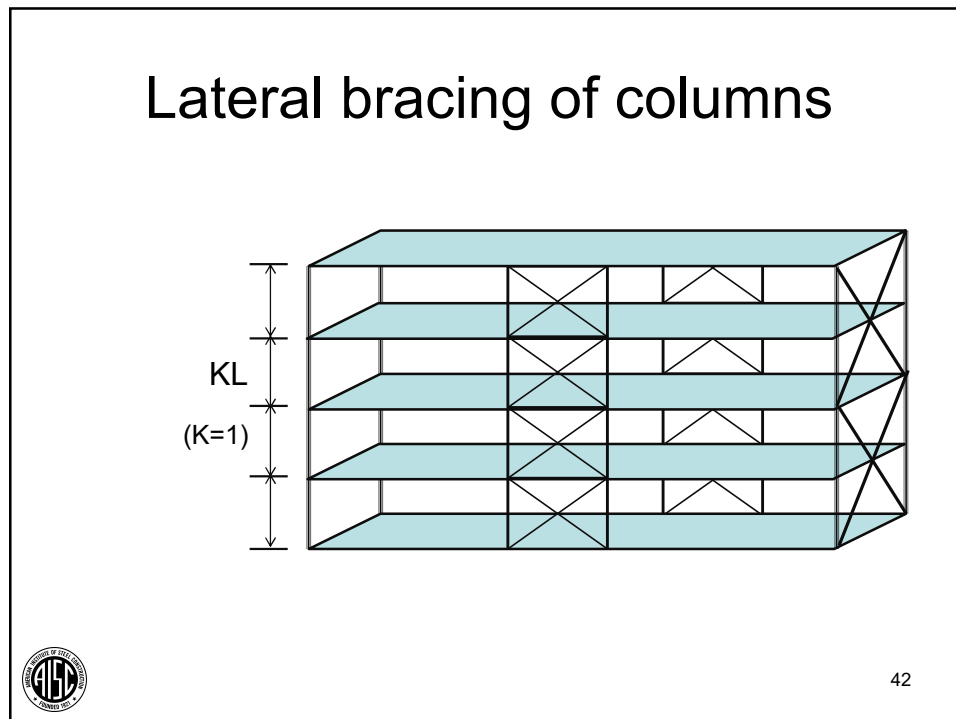
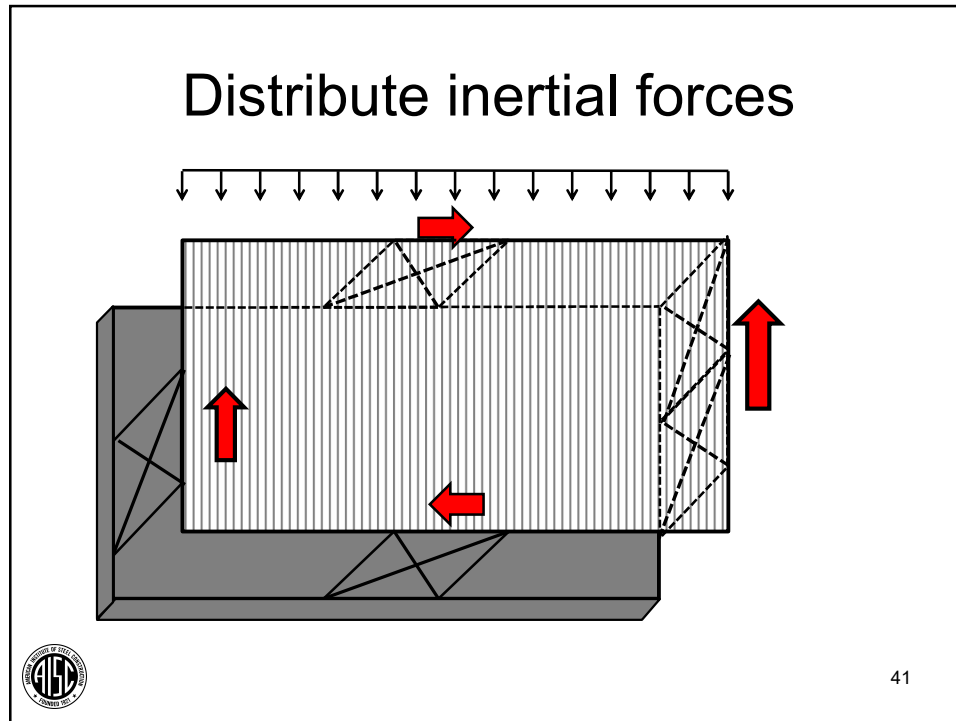

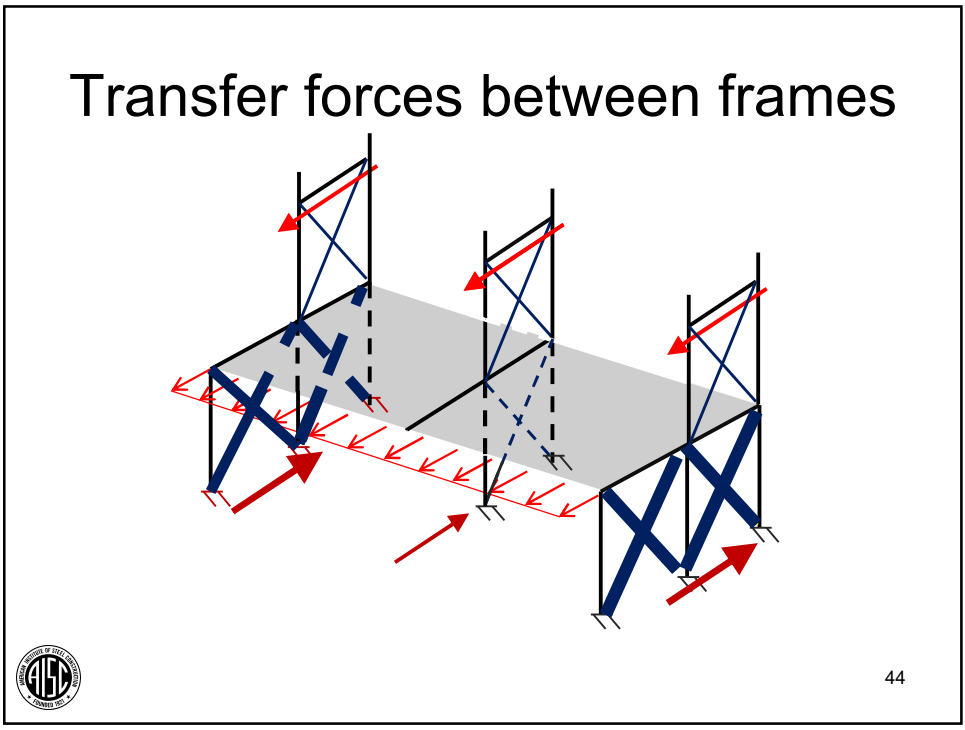
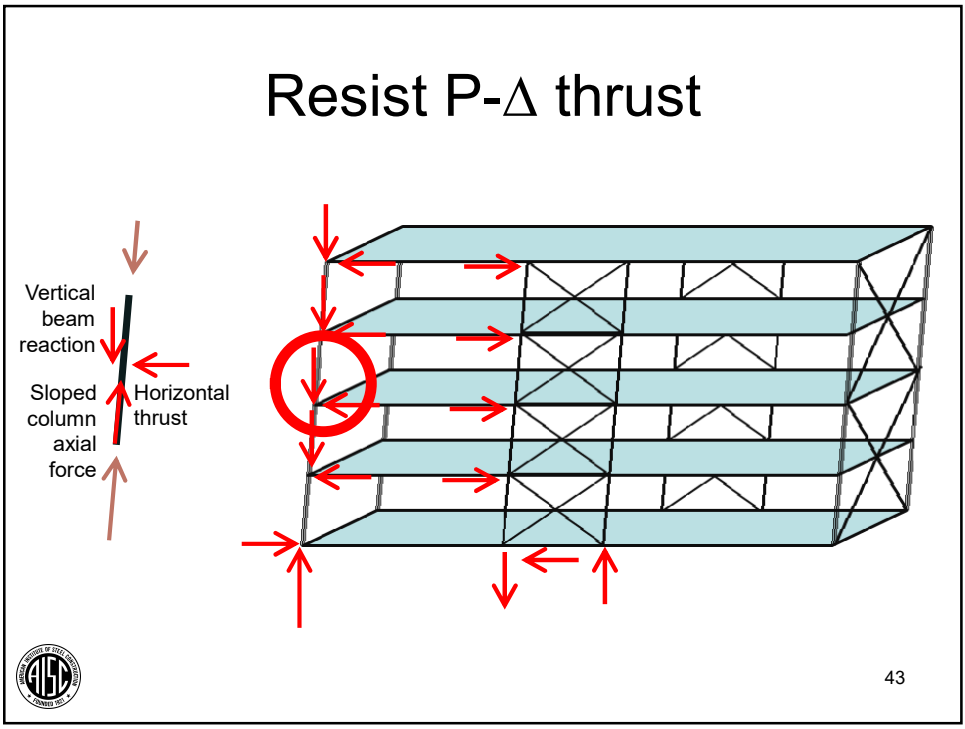

Transfer diaphragms (potential)



45

Transfer diaphragms

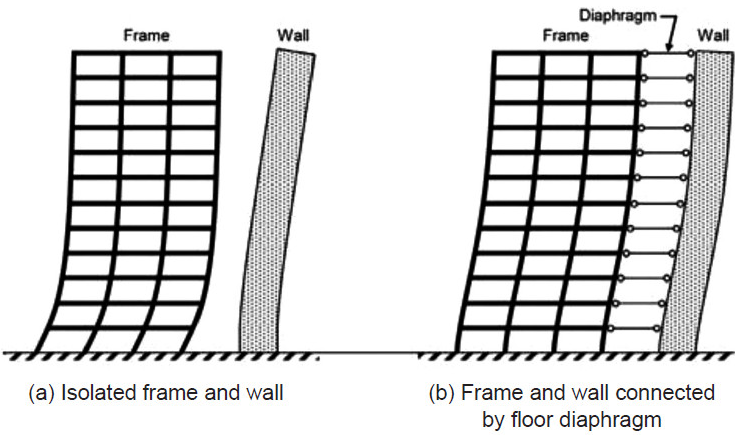

46

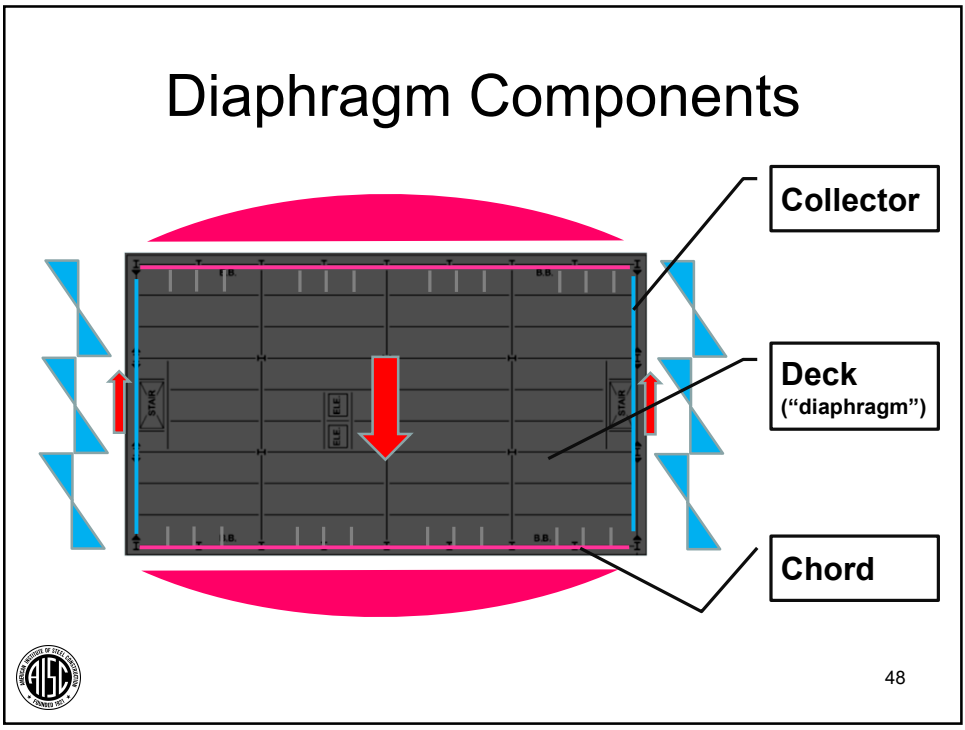
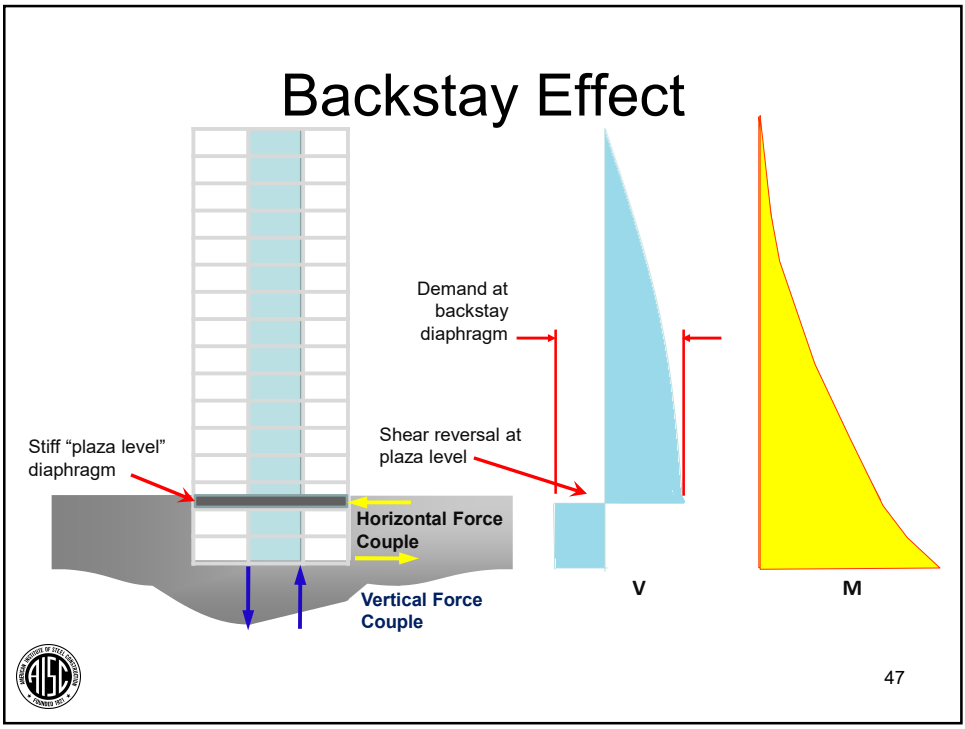

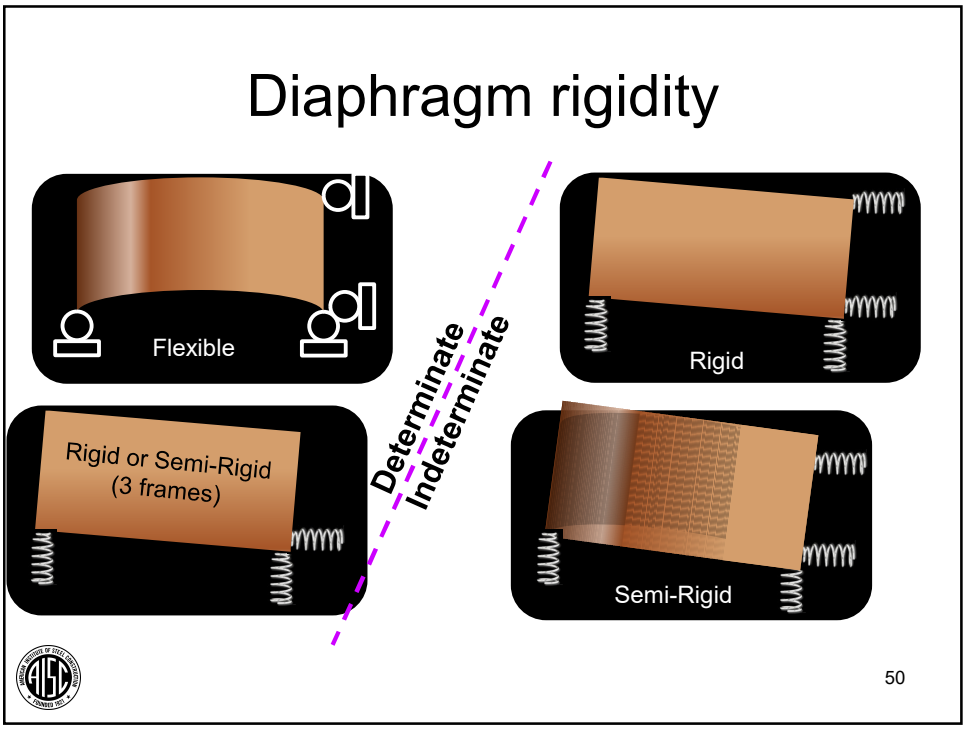
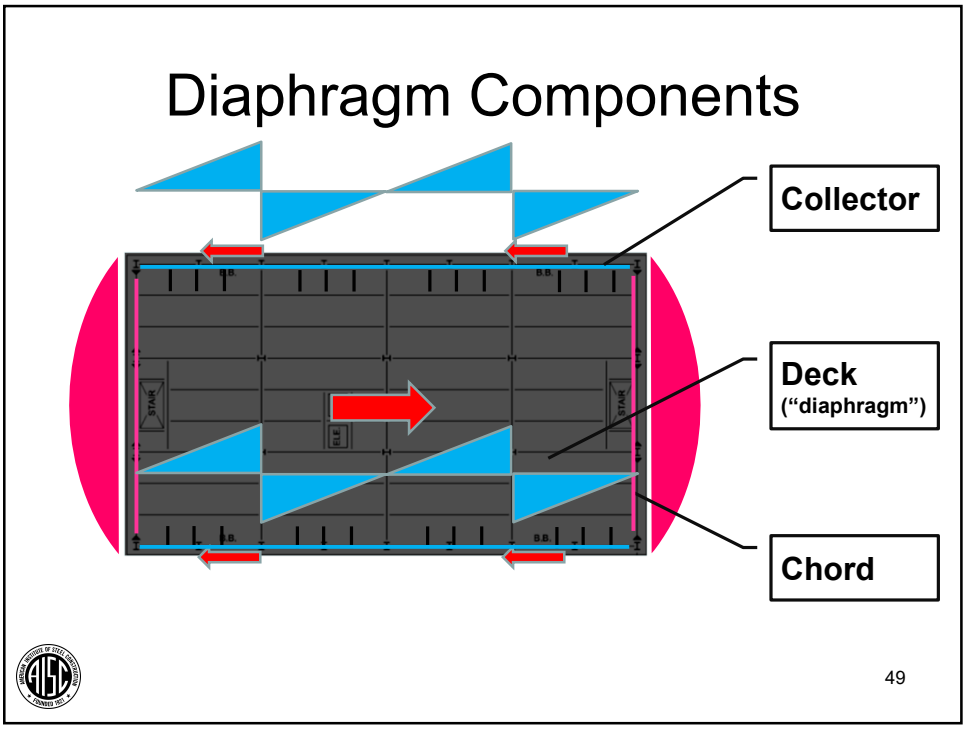

Diaphragm types and analysis

- **Determinate**
 - Flexible, or
 - 3 lines of resistance
 - Analyze diaphragm
 - Diaphragm reactions load frames
- **Indeterminate**
 - Rigid, or
 - Semi-rigid
 - Analyze building
 - Relative frame stiffness
 - Diaphragm rigidity
 - Frame location
 - Forces to frames = diaphragm collector forces



51

Analysis of Flexible Diaphragms

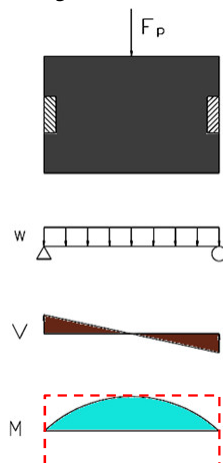

52

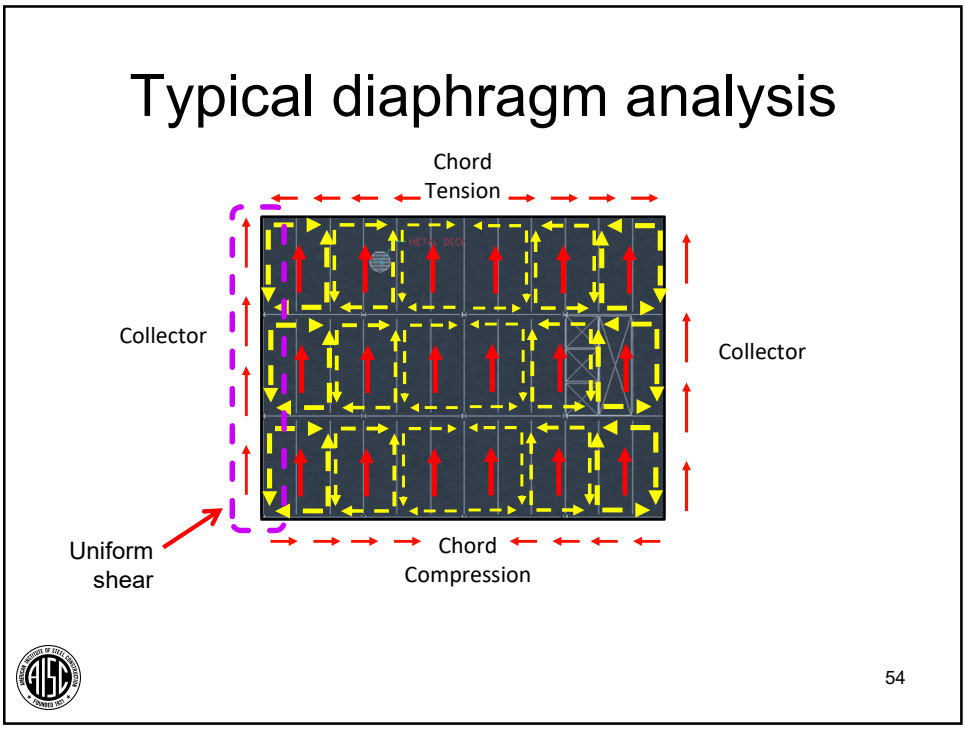
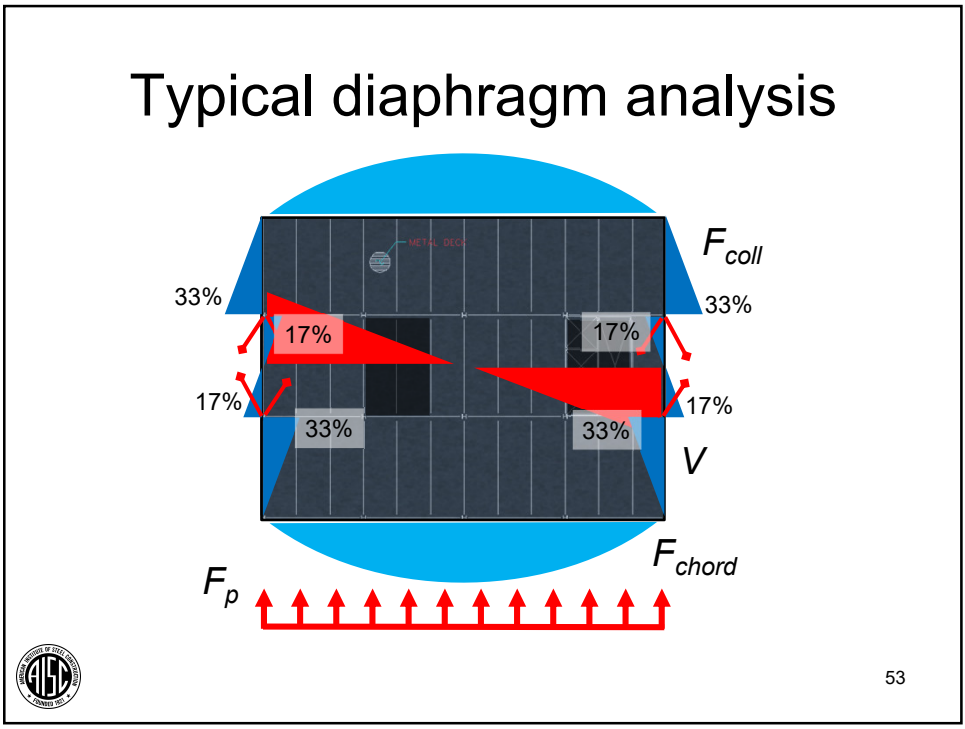

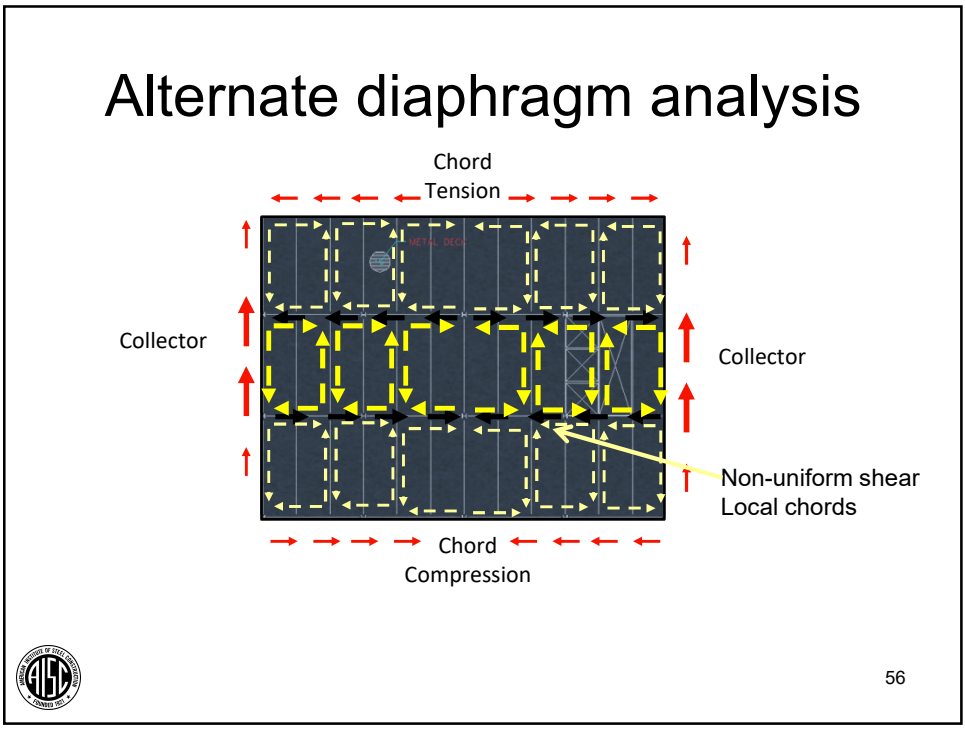
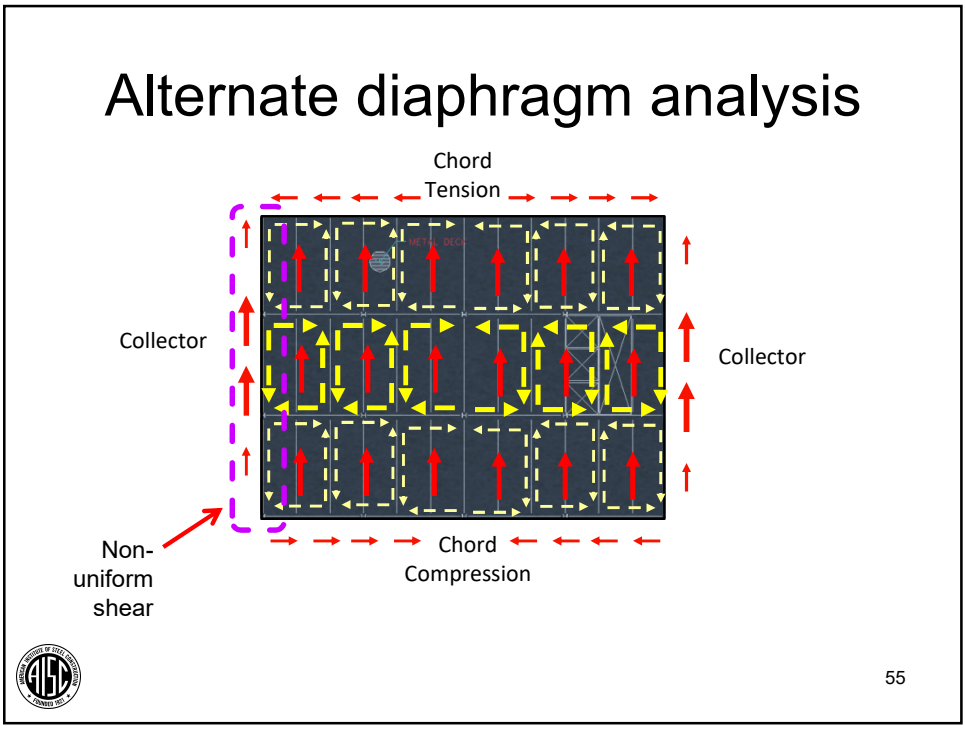

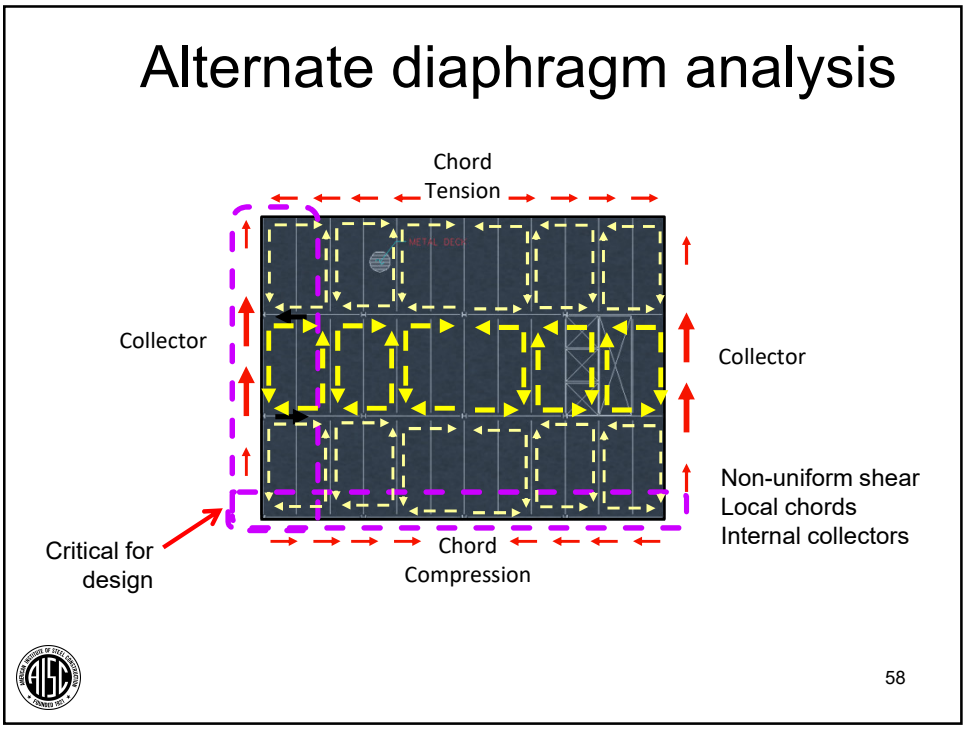
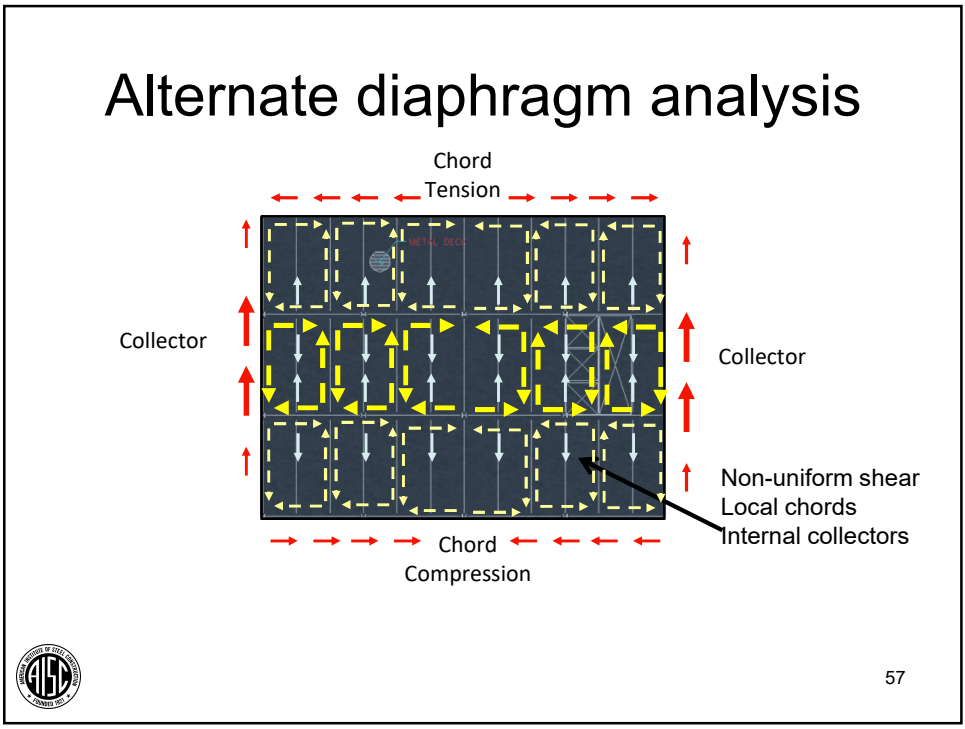

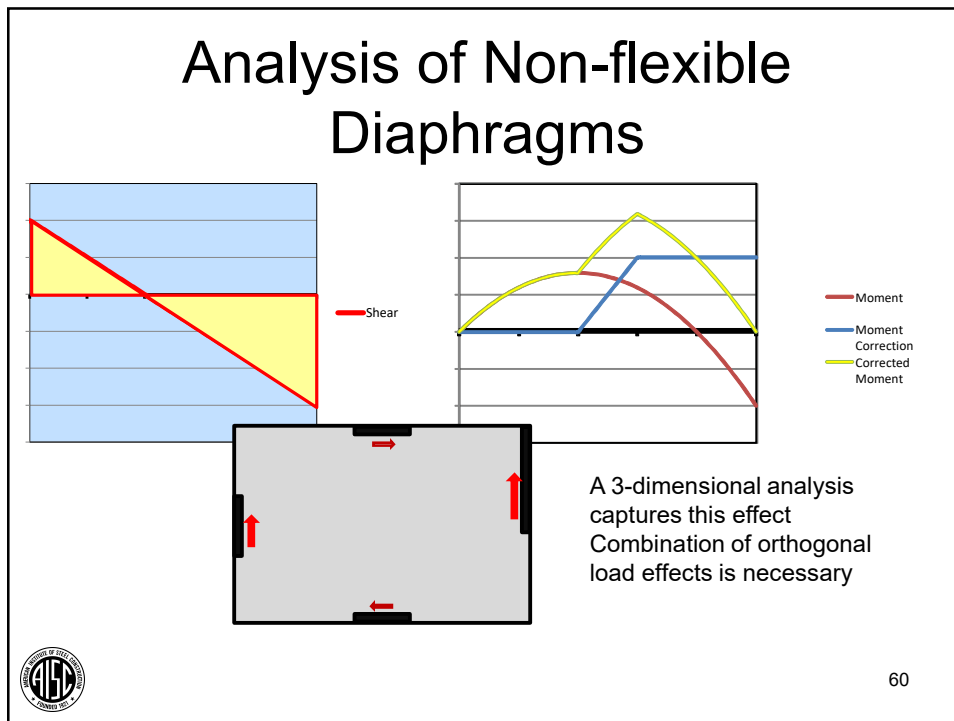
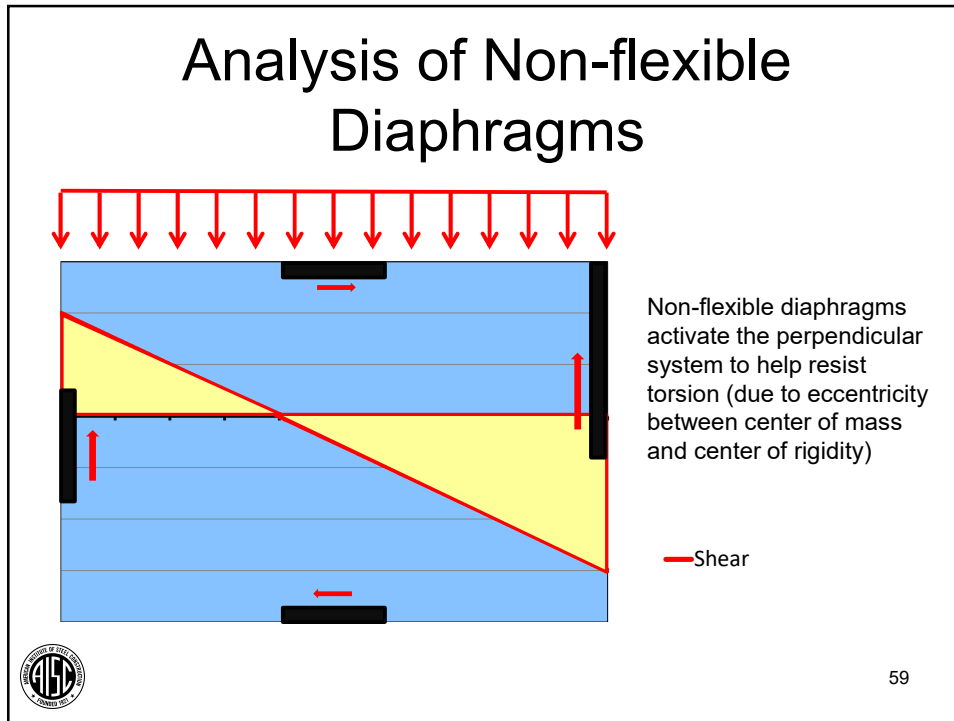

Using the results of 3-D analysis

Critical for design: Collectors and chords

Loading distribution adjusted to satisfy statics



61

Using the results of 3-D analysis

Critical for design: Collectors and chords



62



Collectors

- Protected element
- Reinforcement in composite deck
- Steel framing



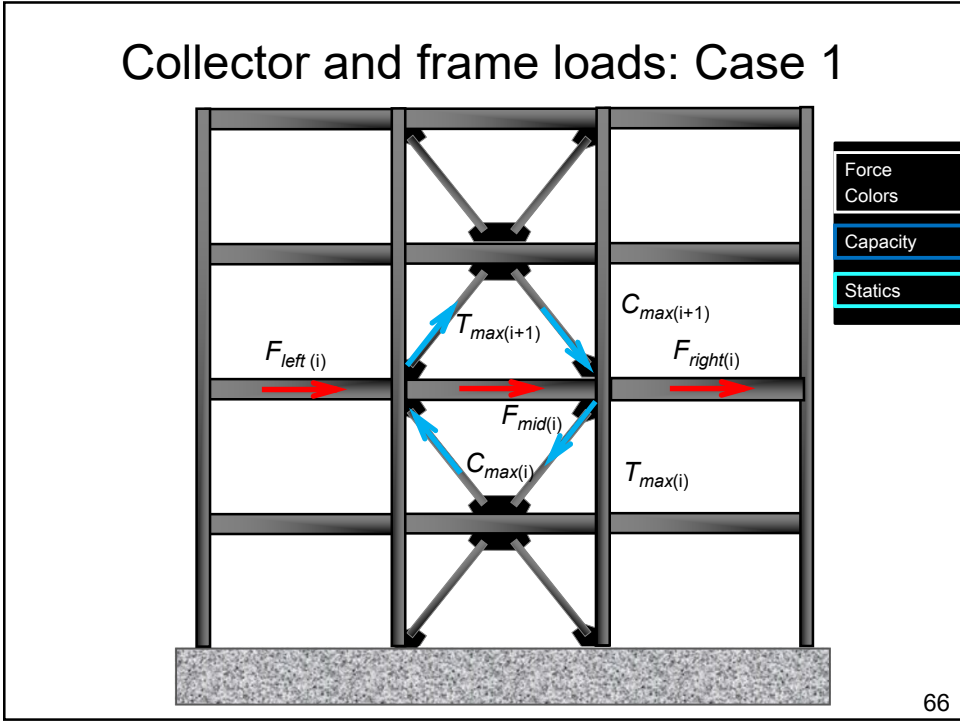
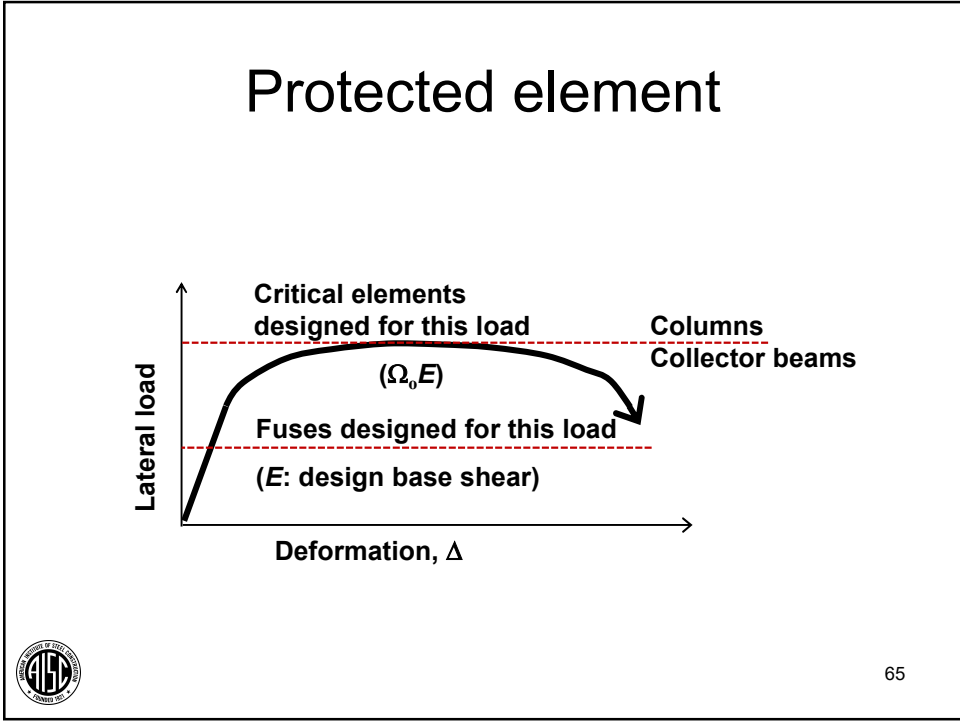

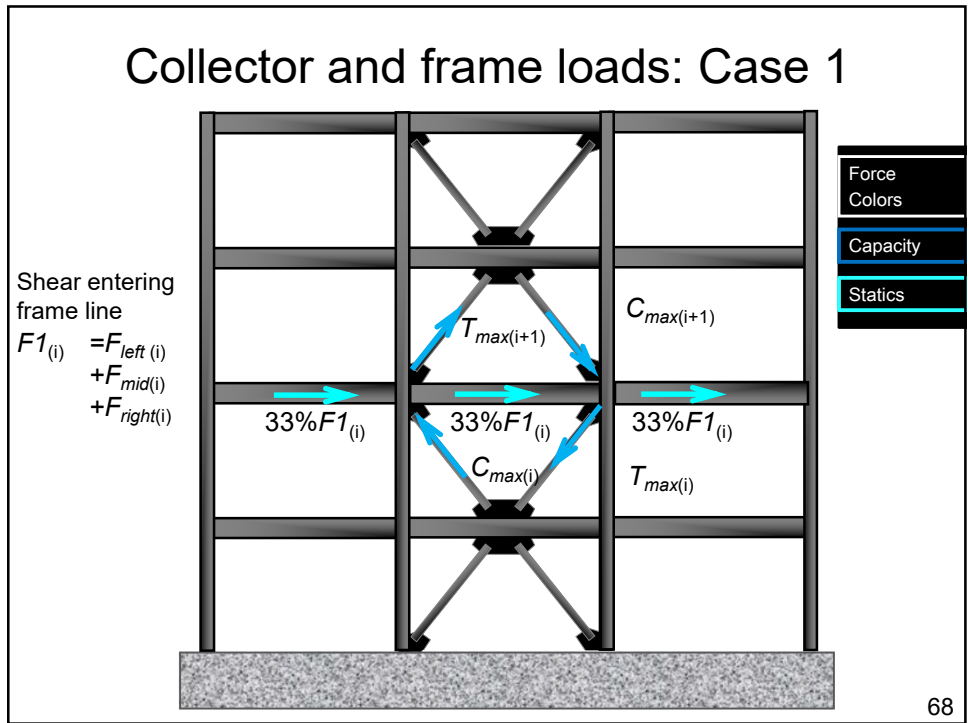
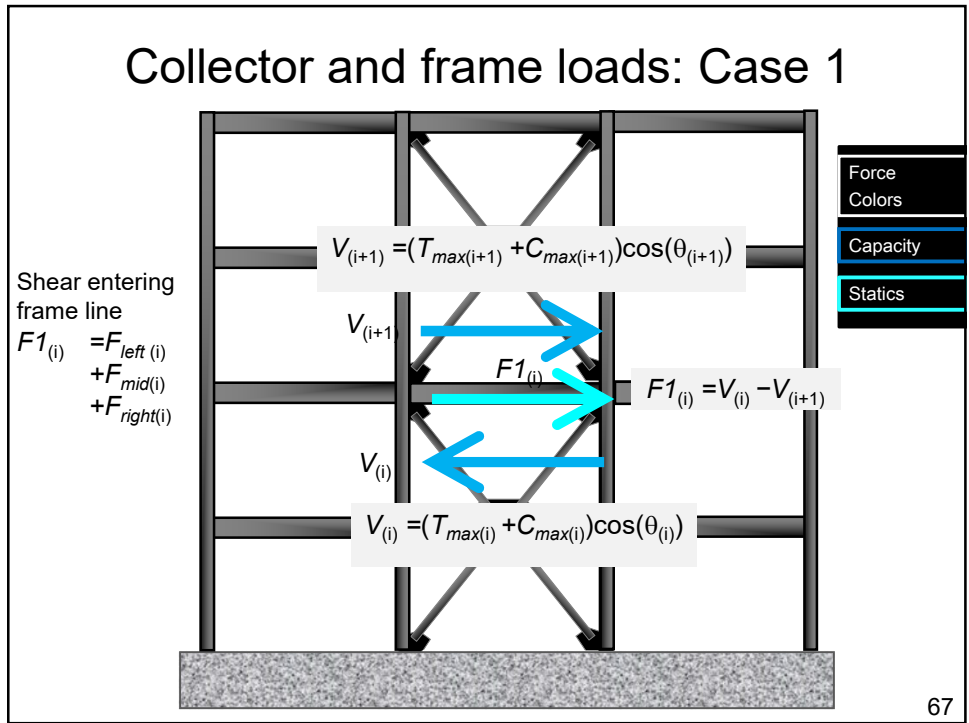

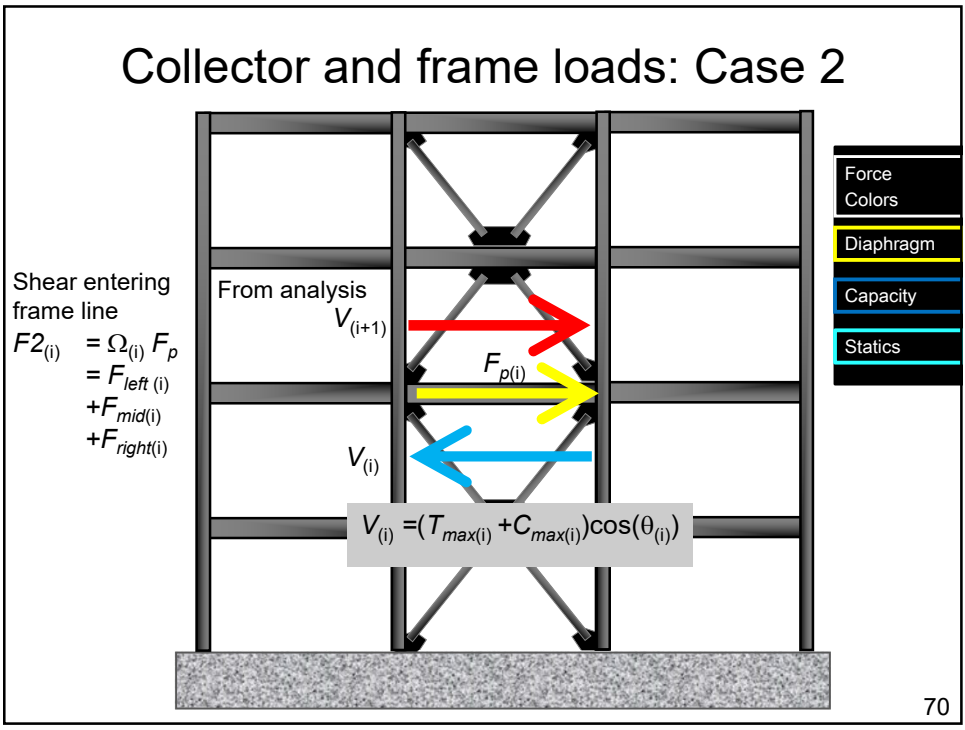
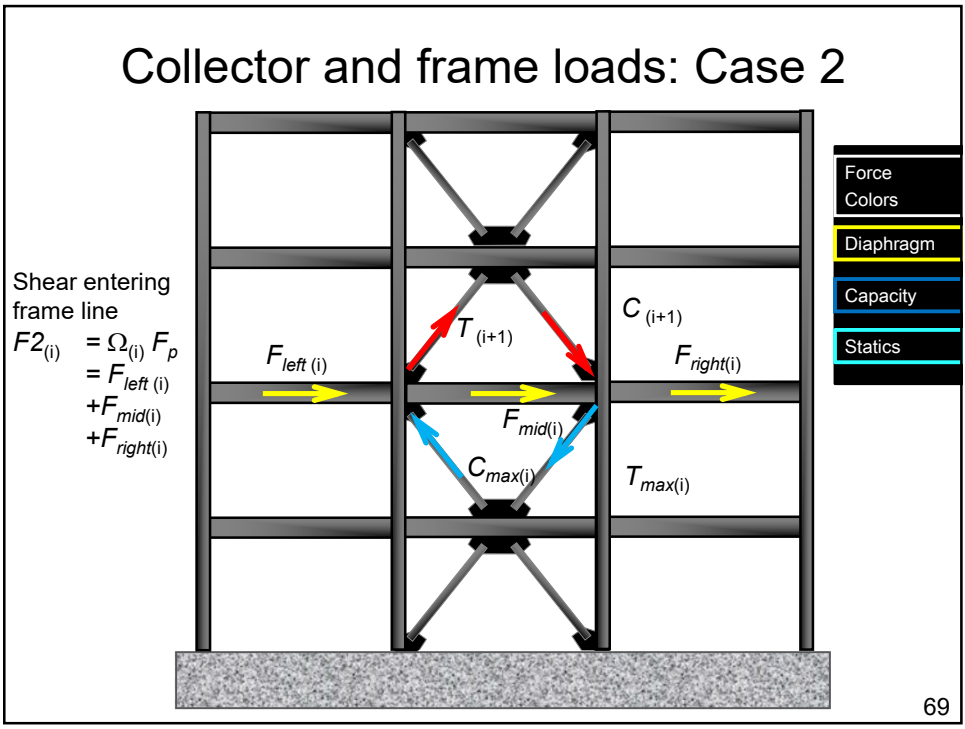

Collector and frame loads: Case 2

$\Omega_{(i)} = [V_{(i)} - F_p] / V_{(i+1)}$

Shear entering frame line
 $F2_{(i)} = \Omega_{(i)} F_p$
 $= F_{left(i)} + F_{mid(i)} + F_{right(i)}$

$V'_{(i+1)} = \Omega_{(i)} V_{(i+1)}$

For static equilibrium $V'_{(i+1)}$

$V_{(i)} = (T_{max(i)} + C_{max(i)}) \cos(\theta_{(i)})$

Force
Colors
Diaphragm
Capacity
Statics

71

Reinforcement in deck

- Wide section of deck
 - Low stress
 - Stability not critical
- Eccentricity from frame
 - Local chords
- Concentrated shear transfer

72

Reinforcement in deck



73

Reinforcement as collector

$$\Omega_o E / A = \leq 0.5 f'_c$$

(unconfined concrete)

$$\Omega_o E / (wt) = \leq 0.5 f'_c$$

$$w \geq \Omega_o E / (0.5 f'_c t)$$

$$e = w/2$$

Local chord force:

$$C = e (\Omega_o E) / L$$

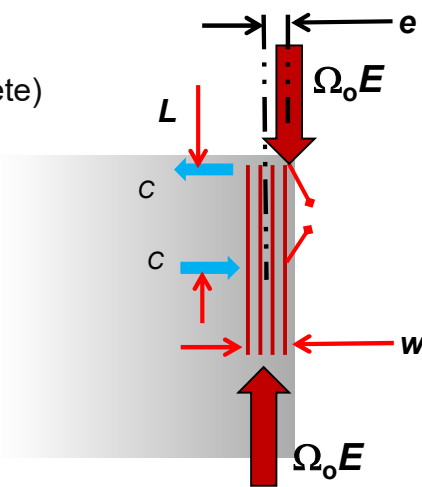

Beam-columns

- Compressive strength
 - Wide-flange with discrete lateral and torsional bracing
 - Major axis flexural buckling
 - Minor-axis flexural buckling
 - Torsional buckling
 - Higher strength than minor-axis FB for same unbraced length

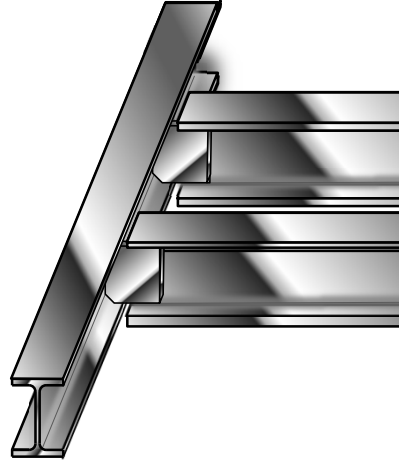

75

Beam-columns

- Compressive strength
 - Wide-flange with continuous lateral bracing
 - Major axis flexural buckling
 - Constrained-axis flexural-torsional buckling
 - Strength between minor-axis FB and torsional buckling

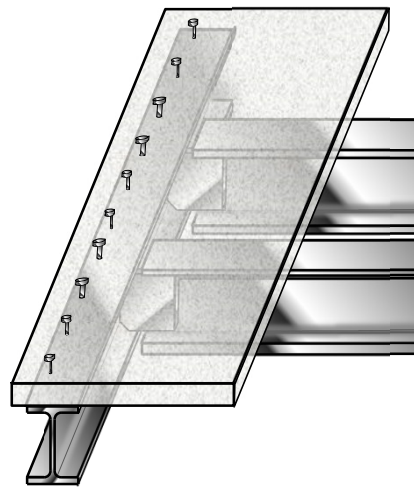

76

Constrained-axis flexural-torsional buckling

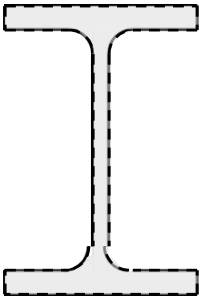

Minor axis flexural buckling
(no restraint)

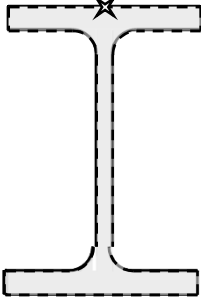

Constrained-axis
Flexural-torsional buckling
(restraint at top flange)

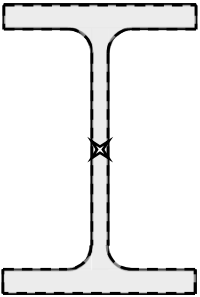



Torsional buckling
(restraint at
centroidal axis)



77

Beam-columns

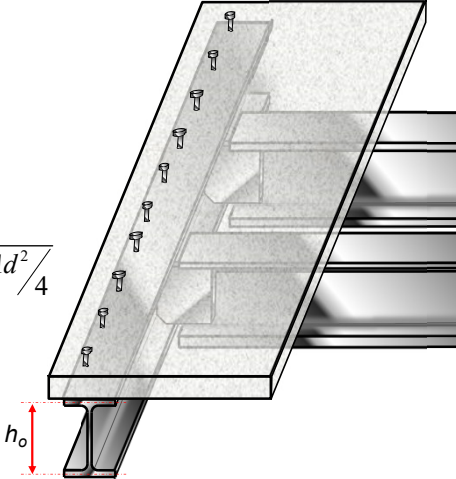
- Constrained-axis flexural-torsional buckling

$$F_{cr} = 0.9 \left[\frac{\pi^2 E I_y (h_o^2 + d^2)}{4(L_{cz})^2} + GJ \right] \frac{1}{I_x + I_y + Ad^2/4}$$



78

Beam-columns

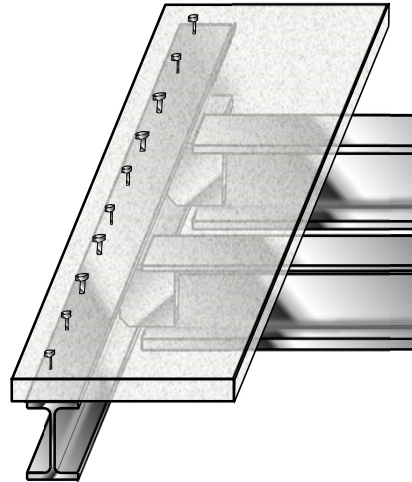
- Compressive strength
 - Wide-flange with continuous torsional bracing
 - Major axis flexural buckling
 - Required torsional stiffness TBD
 - Slab stiffness
 - Web stiffness



79

Table 8-1
Summary of Unbraced Lengths and Restraint Conditions for Collector Beams
(Compressive Strength)

Condition		Major Axis Flexural Buckling Length	Minor Axis Flexural Buckling Length	Constrained-Axis Flexural-Torsional Buckling Length	Torsional Buckling Length
Steel deck	Ribs parallel to beam	Full length	Between lateral brace points	\leq	Between torsional brace points
	Ribs perpendicular to beam	Full length	Not applicable (continuously braced)	\leq Between torsional brace points	Not applicable
Composite deck or slab		Full length	Not applicable (continuously braced)	\leq Between torsional brace points ¹	Not applicable ¹
Horizontal diagonal bracing		Full length	Between lateral brace points	\leq	Between torsional brace points

Beam-columns

- Flexural strength
 - Composite deck
 - Composite strength
 - Steel deck only
 - Lateral bracing with flutes perpendicular
 - Unbraced with flutes parallel

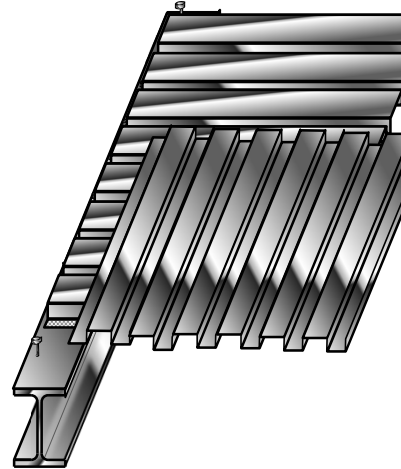

81

Collector connections

- Gravity
 - Shear forces
- Seismic
 - Axial forces (horizontal)
 - Rotation



82

Collector connections

Limit States

- Plate Yield & Rupture
- Bolt shear
- Bearing & Splitting
- Block Shear
- Weld Rupture

83

Collector connections

$$\left(\frac{H_u}{\phi R_n(x)} \right)^2 + \left(\frac{V_u}{\phi R_n(y)} \right)^2 \leq 1$$

$\phi R_n(y)$
from Manual

84

Collector connections

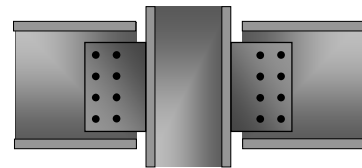
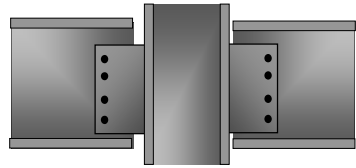

- Rotation
 - Single-plate connection
 - Follow Manual rules
 - Plate thickness
 - Bolt size
 - Spacing
 - Double column of bolts
 - Extended plate method
 - Proportioning rules



85

Collector connections

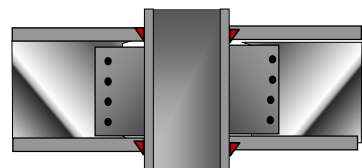
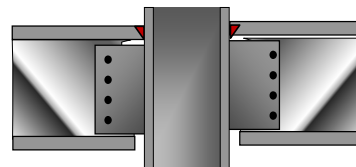

- Rotation
 - Welded top flange
 - Introduces some eccentricity
 - Moment connection
 - Attracts moments
 - May have ductility demands
 - Detail for ductility



86

Deformation compatibility

- Shear distortion adjacent to tall frames
 - Due to
 - Lateral drift
 - Column axial deformation
 - May result in large rotation demands

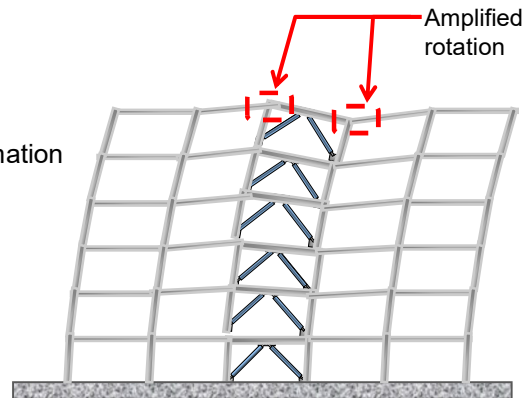

87

Deformation compatibility



Smarter.
Stronger.
Steel.

Deformation compatibility

- Necessity
- Connections
- Flexible diaphragms
- Stairs
- Pounding
- Critical conditions



89

Necessity

- Inelastic response
 - Large drifts
 - Lateral system
 - Gravity system
- Performance goal
 - Prevent collapse
 - Global
 - Local

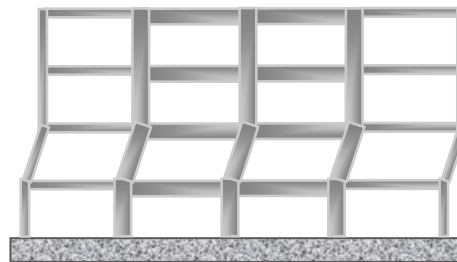

90

Gravity connections

- Connection rotation angle
~ drift angle
- Simple connections in the *Manual* provide inelastic rotation capacity
 - 3% (minimum) for design range
 - Seismic drift assumed to be accommodated

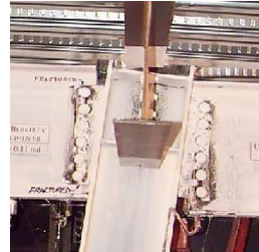

91

Flexible diaphragms

- Diaphragm deformation adds to story drift
- Columns and connections at diaphragm mid-span
 - Increased rotations
 - Increased P- Δ

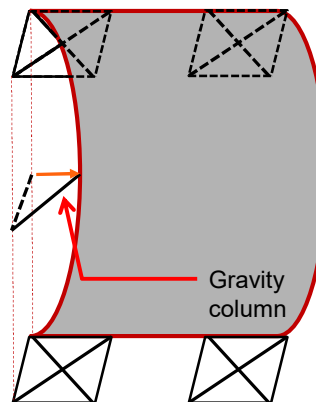

92

Stairs

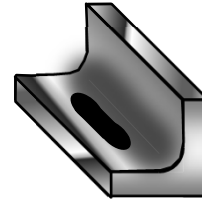

- Act as braces
 - Stiff
- Not ductile
- Continued function necessary
- Detail to allow movement
 - Maintain gravity support

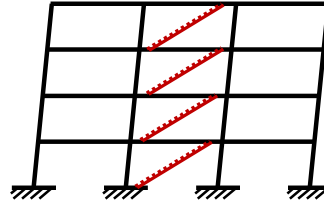

93

Pounding

- Dynamic effects
- Column damage
 - At offset levels

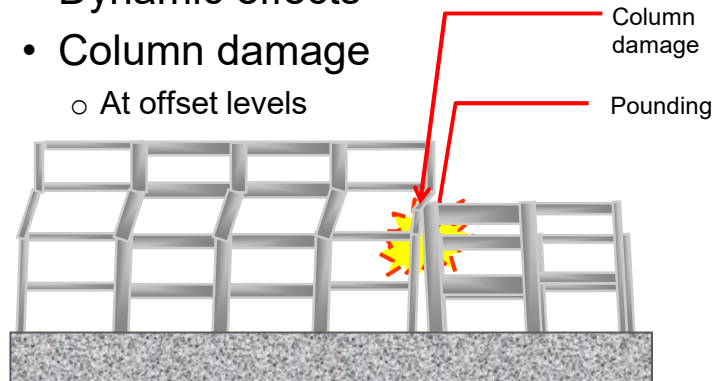

94

Critical conditions

- High consequence
 - Loss of gravity support
 - Loss of egress
- Treat with extra care
 - Estimate upper-bound displacements
 - Absolute sum, not SRSS

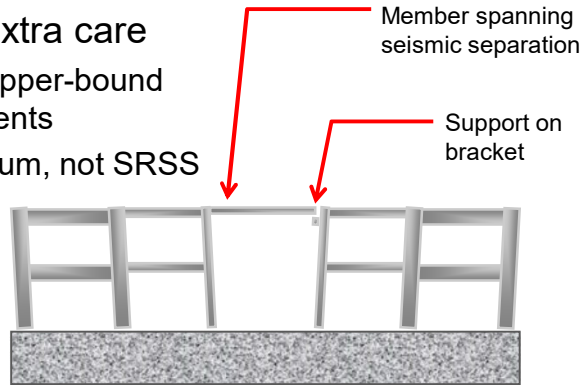

95

Critical conditions

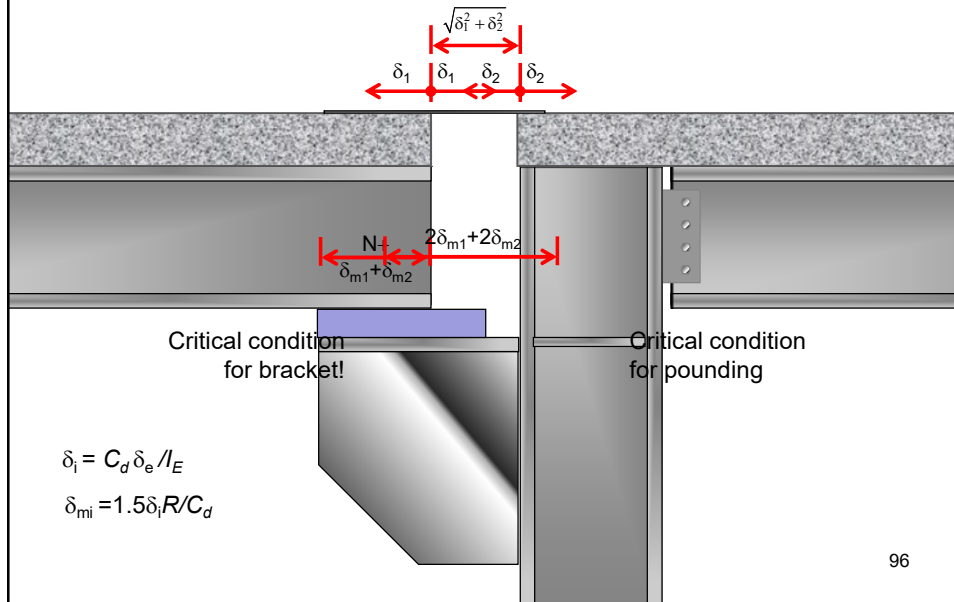

96



Summary

- Structures require a complete load path to maintain stability
- Foundations and diaphragms are an integral part of the load path
- The entire structure must be capable of deforming along with the seismic load resisting system



98



Parting thought

How are these issues treated by building codes?



**Smarter.
Stronger.
Steel.**



End of session 7

Next:
**Session 8:
Building codes**



**Smarter.
Stronger.
Steel.**

Additional resources

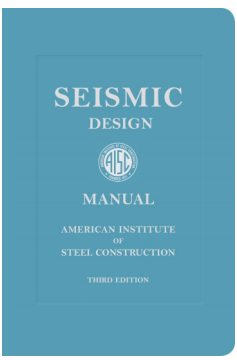
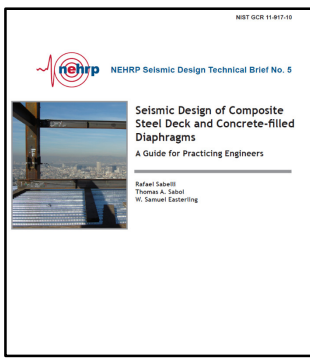

<http://www.nehrp.gov/pdf/nistgcr11-917-10.pdf>



The background of this slide is a grayscale photograph of a large steel structure being tested in a laboratory. The structure is supported by a complex system of beams and columns. Overlaid on the bottom half of the image is a white rectangular box containing the text 'Question time' in a large, bold, black font. In the bottom right corner of the slide, there is the AISC logo and the slogan 'Smarter. Stronger. Steel.' in blue text.

Single-Session Registrants

CEU / PDH Certificates

- Reporting site (URL will be provided in the forthcoming email).
- Username: Same as AISC website username.
- Password: Same as AISC website password.



8-Session Registrants

CEU / PDH Certificates

One certificate will be issued at the conclusion of the course.



8-Session Registrants

CEU / PDH Certificates

One certificate will be issued at the conclusion of the course.



8-Session Registrants

Attendance and PDH Certificates

- You have two options to receive credit for a given session.
 - Option 1: Watch the live session. Credit for live attendance will be displayed on the Course Resources table within two days of the session.
 - Option 2: Watch the recording and pass the associated quiz.

Videos and Quizzes

- For each session, find access within two business days after the live air date. (An email will be sent from night school@aisc.org.)
- Reasons for quiz:
 - EEU – You must take all quizzes and the final exam to receive EEU.
 - PDHs – If you watch a recorded session, you must pass quiz for PDHs.
 - Reinforce what you learn in the lectures and get more out of the course!

Distribution of Certificates

All certificates will be issued after the course is completed. Only the registrant will receive a certificate for the course.



8-Session Registrants

Course Resources

Find all your handouts, quizzes and quiz scores, recording access, and attendance information in one place!



8-Session Registrants

Course Resources

Go to www.aisc.org and sign in.

8-Session Registrants

Course Resources

Go to www.aisc.org and sign in.

IN THIS SECTION

- Edit Profile
- My Downloads
- My Pending Quizzes
- My Events
- Order History
- Course History
- Course Resources**

MyAISC

MY PROFILE
Update your contact and address information.

[EDIT PROFILE](#)

MY PURCHASED DOWNLOADS
Access articles and documents that you have purchased.

[VIEW DOWNLOADS](#)

MY COURSE RESOURCES
View online resources for Night School and Live Webinar package registrations.

[VIEW RESOURCES](#)

8-Session Registrants

Course Resources



EDUCATION PUBLICATIONS AWARDS AND COMPETITIONS TECHNICAL RESOURCES STEEL SOLUTIONS CENTER



AISC

AISC > MY ACCOUNT > COURSE RESOURCES

Course Resources

Event	Start Date
Seismic Design in Steel	1/1/1900 12:00:00 AM
4-Session Package-Design of Facade Attachments	5/9/2019 1:30:00 PM
NS 15 B-Session Package-Night School 15 - Fundamentals of Connection Design	10/3/2017 7:00:00 PM
NS 16 B-Session Package-Night School 16 - Seismic Design in Steel	2/5/2018 7:00:00 PM
NS 17 A-Session Package-Night School 17- Design of Facade Attachments	7/16/2018 7:00:00 PM
NS 18 B-Session Package-Night School 18- Steel Construction: Mill To Topping Out	10/15/2018 7:00:00 PM
NS 19 B-Session Package-Night School 19- Connection Design	2/4/2019 7:00:00 PM
NS 20 B-Session Package-Night School 20- Classical Methods of Structural Analysis	6/3/2019 7:00:00 PM
8-Session Package-Seismic Design in Steel - Concepts & Examples	7/16/2018 1:30:00 PM

8-Session Registrants

Course Resources

AISC

AISC > MY ACCOUNT > COURSE RESOURCES > NS24 8-SESSION PACKAGE RESOURCES

Night School 24: Modern Methods for Learning Structural Stability

8-SESSION PACKAGE RESOURCES

Event	Date	Handouts	Video	Quiz	Attendance
NS24.1 - Compression Members - The Fundamentals	Oct 6 2020 7:00PM EDT	Handouts	Available 10/08/2020 5:00PM EDT	Available 10/08/2020 5:00PM EDT	Pending
NS24.2 - Compression Members - Practical Considerations	Oct 13 2020 7:00PM EDT	Handouts	Available 10/15/2020 5:00PM EDT	Available 10/15/2020 5:00PM EDT	Pending
NS24.3 - Behavior of Flexural Members - The Fundamentals	Oct 20 2020 7:00PM EDT	Handouts	Available 10/22/2020 5:00PM EDT	Available 10/22/2020 5:00PM EDT	Pending
NS24.4 - Flexural Members - Practical Considerations	Oct 27 2020 7:00PM EDT	Handouts	Available 10/29/2020 5:00PM EDT	Available 10/29/2020 5:00PM EDT	Pending
NS24.5 - Stability of Beam-Columns - The Fundamentals	Nov 10 2020 7:00PM EST	Handouts	Available 11/12/2020 5:00PM EST	No longer available	Pending
NS24.6 - Stability of Beam-Columns - Practical Consideration	Nov 17 2020 7:00PM EST	Handouts	Available 11/19/2020 5:00PM EST	No longer available	Pending
NS24.7 - Behavior of Structural Systems - The Fundamentals	Dec 1 2020 7:00PM EST	Handouts	Available 12/03/2020 5:00PM EST	No longer available	Pending
NS24.8 - Structural Systems - Practical Considerations	Dec 8 2020 7:00PM EST	Handouts	Available 12/10/2020 5:00PM EST	No longer available	Pending
NS24 - Final Exam	N/A			No longer available	Pending

AISC | Thank you.



**Smarter.
Stronger.
Steel.**