



**Night School 26:
Developing an Eye for
Connection Design**

Thank you for joining our live webinar. We will begin shortly. Please standby.



Session 2 – Communication
June 29, 2021 | Larry Muir



**Smarter.
Stronger.
Steel.**

AISC Live Webinars

Today's live webinar will begin shortly. Please stand by.

Today's audio will be broadcast through the internet. Please be sure to turn up the volume on your speakers.

Please type any questions or comments in the Q&A window.



AISC Live Webinars

AIA Credit

AISC is a Registered Provider with The American Institute of Architects Continuing Education Systems (AIA/CES). Credit(s) earned on completion of this program will be reported to AIA/CES for AIA members. Certificates of Completion for both AIA members and non-AIA members are available upon request.

This program has been submitted for AIA/CES for continuing professional education. As such, it does not include content that may be deemed or construed to be an approval or endorsement by the AIA of any material of construction or any method or manner of handling, using, distributing, or dealing in any material or product.

Questions related to specific materials, methods, and services will be addressed at the conclusion of this presentation.



AISC Live Webinars

Copyright Materials

This presentation is protected by US and International Copyright laws. Reproduction, distribution, display and use of the presentation without written permission of AISC is prohibited.

© The American Institute of Steel Construction 2021

The information presented herein is based on recognized engineering principles and is for general information only. While it is believed to be accurate, this information should not be applied to any specific application without competent professional examination and verification by a licensed professional engineer. Anyone making use of this information assumes all liability arising from such use.



AISC Live Webinars

Course Description

Communication June 29, 2021

This session will focus on the responsibilities, relationships and communication among the various parties involved in the connection design process. It will discuss how delegated connection design is addressed in the AISC Code of Standard Practice. Ways in which proper communication between the engineers can be maintained to ensure the safety of the structure while also addressing concerns about contract management will also be presented. Finally, some general tips for those wishing to perform delegated connection design will be provided.



AISC Live Webinars

Learning Objectives

1. List the three different connection design options described in the AISC Code of Standard Practice, Section 3.1.1.
2. Define delegated connection design.
3. List the required information provided by the EOR when delegated connection design is employed.
4. List the responsibilities of the delegated connection design engineer when delegated connection design is employed.



Night School 26: Developing an Eye for Connection Design

Session 2: Communication
June 29, 2021

Larry Muir, PE, Consultant

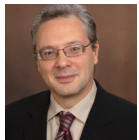

DEVELOPING AN EYE FOR CONNECTION DESIGN

by Larry S. Muir, P.E.



Communication

The Basics



Communication

All communication is imperfect.

You cannot know exactly what I intend.

I cannot know precisely what you think I intend.



10

Learning & Teaching

I have become convinced that no one can teach anyone else anything.

I can introduce ideas, and you can choose to pursue them and integrate them into your worldview or not.

Presentations like these are the beginning of the process not the end.



11

Signal-to-Noise

Communication

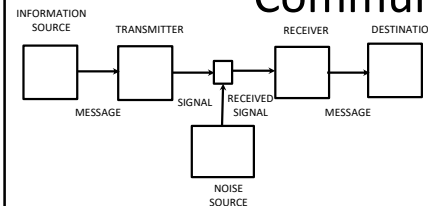

Claude Shannon. "A mathematical theory of communication". *Bell System Technical Journal*, 1948.

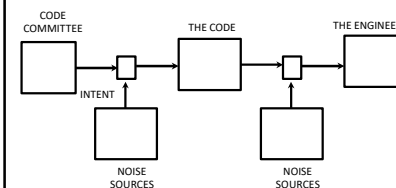

Shannon's model applied to Codes

12

Signal-to-Noise

Communication

Shannon's model applied to this presentation

Whether we are concerned with design standards, design examples, or this presentation common understanding of basic engineering principles can help us overcome the limitations of language and communication.



13

Communication in Connection Design

The Basics



14

Communication in Connection Design

Much of this session concentrates on communication between the Engineer of Record and the delegated connection design engineer. Since these two engineers work for different parties and may have no relationship beyond the current project, communication can be especially challenging.

Even when main member design and connection design are both performed within a single company the two functions may be performed by different individuals or groups and therefore the communication issues discussed may still be applicable – though perhaps to a lesser extent.



15

Responsibility

Responsibility

Rule #1: Connection design must be overseen by a professional engineer.

- Responsibility must be defined:
 - Relative to the performance of tasks
 - Adequacy of design within the parameters set

Detailers cannot practice engineering and cannot be responsible for assessing the adequacy of design.



16

Responsibility

Responsibility

Delegated connection engineers (delegates) are responsible for designing connections to satisfy the requirements specified by the Engineer of Record.

The Engineer of Record is responsible for conveying the performance requirements and for ultimately ensuring that they have been correctly interpreted.



17

Responsibility

Responsibility

In my experience as a delegated connection engineer, it can often be difficult to get complete and reliable information from Engineers of Record.

This makes my job more difficult.

It is bad for the project.

It seems especially dangerous for the Engineer of Record.

18

Responsibility

Responsibility

I am not a lawyer, but I suspect that no amount of fancy language can relieve the Engineer of Record of responsibility for impact of connection details on the overall structural performance of the project.

Therefore, providing complete and reliable information would seem to be in the best interest of Engineers of Record.



19

Responsibility

Responsibility - Clearly Stated

Specification Section B1: "The design of members and connections shall be consistent with the intended behavior of the framing system and the assumptions made in the structural analysis."



20

Responsibility

Responsibility - Clearly Stated

Specification Section B1: “The design of members and connections shall be consistent with the intended behavior of the framing system and the assumptions made in the structural analysis.”

CoSP Commentary: “From the inception of this Code, AISC and the industry in general have recognized that only the owner’s designated representative for design has all the information necessary to evaluate the total impact of connection details on the overall structural design of the project.”

21

Responsibility

Responsibility

In order to ensure that the design of connections is consistent with the intended behavior the EoR can place restrictions on the types of connections that are permitted.

Indicating that connections shall comply with connections in the Manual is not useful when the conditions that must be designed are not addressed in the Manual. In such cases this can result in situations where a connection that looks like something in the Manual is used to address a condition it is not well-suited for.

22

Responsibility

Shared Responsibility

Only the EoR has all the information necessary...

AND

The EoR has a responsibility to provide sufficient information...

BUT

The fabricator and the connection design engineer also have a responsibility to ensure (to a reasonable extent) that they have the information they need and that it makes sense...

23

Responsibility

Responsibility - Clearly Stated – In a Few States

New York provides some good requirements:

“(i) such specifically defined design work shall be limited to project components ancillary to the main components of the project”

“(ii) the delegator shall specify... to the delegatee... parameters which the design must satisfy”



24

Responsibility

Responsibility - Clearly Stated – In a Few States

New York provides some good requirements:

“(iii) the design [shall perform] in accordance with performance specifications established by the delegator”

“(v) the delegator shall be required to review... for conformance with the established specifications and parameters...”

“(vi) the delegator shall... determine that the design... conforms to the overall project design...”

25

Responsibility

Responsibility - Logic Check

Someone must be responsible for the design of every aspect of the project.

Someone must be responsible for ensuring that someone is responsible for the design of every aspect of the project.

If it is not clear who is responsible and you perceive that others perceive you are responsible and you disagree, then it seems like a good idea to clear up the potential misunderstanding.

26

CoSP



Code of Standard Practice for Steel Buildings and Bridges



27

CoSP

Code of Standard Practice

ANSI/ASCE 301-16
An American National Standard

Code of Standard Practice
for Steel Buildings
and Bridges

June 17, 2016

Supersedes the Code of Standard Practice for Steel Buildings and Bridges
dated March 14, 2010 and all previous versions.

Approved by the Committee on the Code of Standard Practice



AMERICAN INSTITUTE OF STEEL CONSTRUCTION
130 East Randolph Street, Suite 2000, Chicago, Illinois 60601

- The AISC Code of Standard Practice (CoSP) forms the basis of structural steel construction contracts.
- It sets forth criteria for the trade practices involved in steel buildings, bridges and other structures.

28

CoSP

Code of Standard Practice

ANSI/ASCE 103-16
An American National Standard

Code of Standard Practice
for Steel Buildings
and Bridges

June 15, 2016
Supersedes the Code of Standard Practice for Steel Buildings and Bridges
dated March 14, 2010 and all previous versions
Approved by the Committee on the Code of Standard Practice



AMERICAN INSTITUTE OF STEEL CONSTRUCTION
200 East Randolph Street, Suite 2000, Chicago, Illinois 60601

- The CoSP is developed by a committee, representing various aspects of the structural steel construction industry.
- The CoSP has proven to be an effective, fair and legally-acceptable document for its nearly 100-year history.

29

CoSP

Three Options

Section 3.1.1 requires the owner's designated representative for design (EoR) to indicate one of three options for each connection:

- Option 1: Complete connection design shown in the structural design documents.
- Option 2: Connection selected or completed by an experienced steel detailer.
- Option 3: Connections designed by a licensed engineer working for the fabricator. (Delegated Design)



30

CoSP

What is Delegated Connection Design?

Design of the connection details is delegated to a licensed engineer working for the fabricator.

It cannot be said enough, detailers cannot practice engineering and cannot be responsible for assessing the adequacy of design.

Under Option 2 detailers are paid to *draw pretty pictures* of connections that will fit-up and are generally consistent with "reference information as approved by the owner's designated representative for design".

31

CoSP

Who's the Boss?

- Safety first.
- The EoR is the final authority.
- Section 4.4 of the CoSP states, "The owner's designated representative for design is the final authority in the event of a disagreement between parties regarding the design of connections to be incorporated into the overall structural steel frame."



32

CoSP

Substantiating Connection Information

The Substantiating Connection Information is intended to ensure early in the project that the two engineers are communicating properly.

The Substantiating Connection Information allows potential controversies to be identified and resolved early in the project.

The Substantiating Connection Information can reduce (or eliminate) changes and reduce the cost of changes.



37

Communication Is the Key to Avoiding Problems

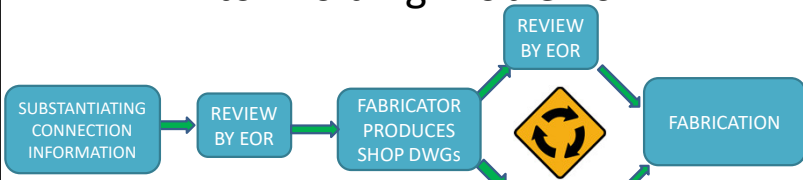

The approval process described in the Code of Standard Practice is intended to ensure that the necessary communication occurs and that the design intent is satisfied.



38

Avoiding Problems

Communication Is the Key

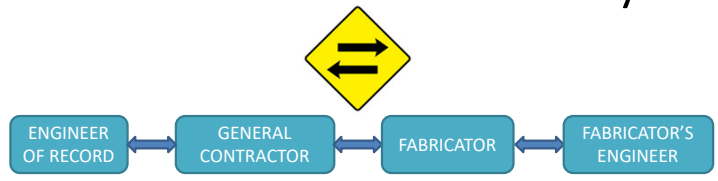

Non-ideal communication path



39

Avoiding Problems

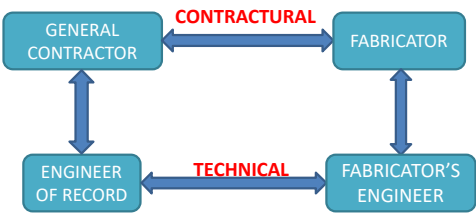

Communication Is the Key



Better communication path



40

 **Communication Is the Key** 

- Knowledge is Power.
- To be useful knowledge must be communicated and shared.
- There can sometimes be a perception that maintaining power requires maintaining control of communication.
- For contractual considerations contractors tend to insert themselves into the path of technical communication.

   41

Avoiding Problems **Communication Is the Key**

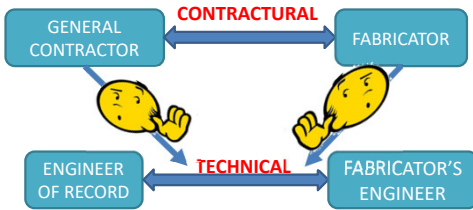

Another communication path

 42



Communication Is the Key
When Problems Arise





Resolving Problems **When Problems Arise**

 **Discrepancy:** an unexpected difference, esp. in two amounts or two sets of facts or conditions, which suggests that something is wrong and has to be explained.

Most issues that arise during delegated connection design are in effect discrepancies.

Some information seems inconsistent within the context of the other information provided and this perceived inconsistency must be resolved.

 44

Resolving Problems

Discrepancies



Discrepancies are addressed in the Code of Standard Practice.

3.3. Discrepancies

When discrepancies exist between the *design documents* and *specifications*, the *design documents* shall govern. When discrepancies exist between scale dimensions in the *design documents* and the figures written in them, the figures shall govern. When discrepancies exist between the structural *design documents* and the architectural, electrical or mechanical *design documents*, or the *design documents* for other trades, the structural *design documents* shall govern. When discrepancies exist between the *design drawings* and the *design model*, the governing document shall be as identified per Section 1.4.

When a discrepancy is discovered in the *contract documents* in the course of the *fabricator's* work, the *fabricator* shall promptly notify the *owner's designated representative for construction* so that the discrepancy can be resolved. Such resolution shall be timely so as not to delay the *fabricator's* work. See Sections 3.5 and 9.3.

It is not the *fabricator's* responsibility to discover discrepancies, including those that are associated with the coordination of the various design disciplines.



45

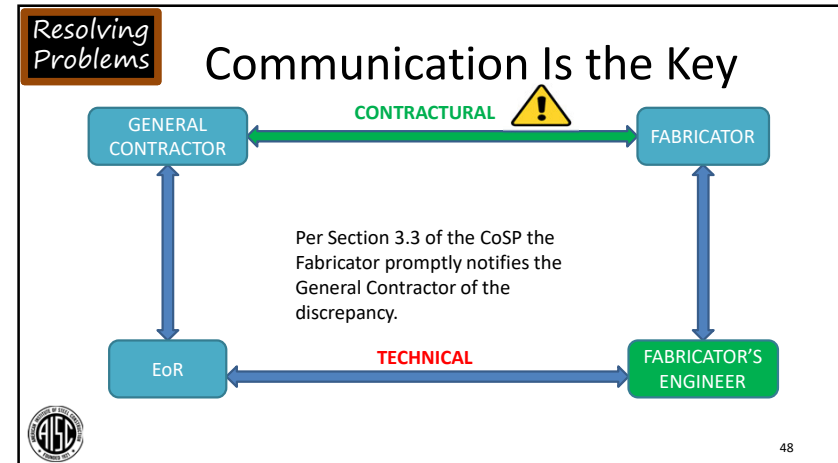
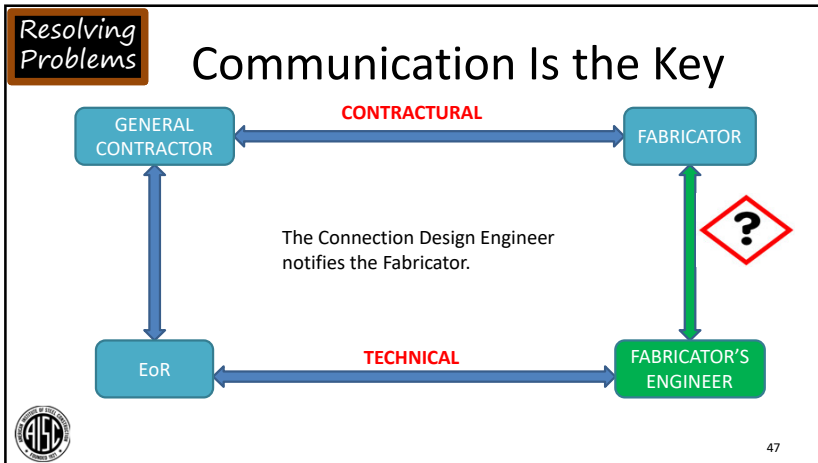
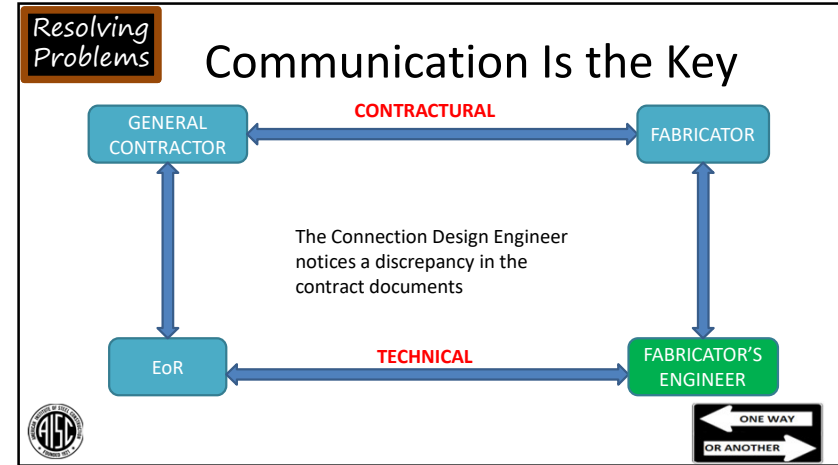

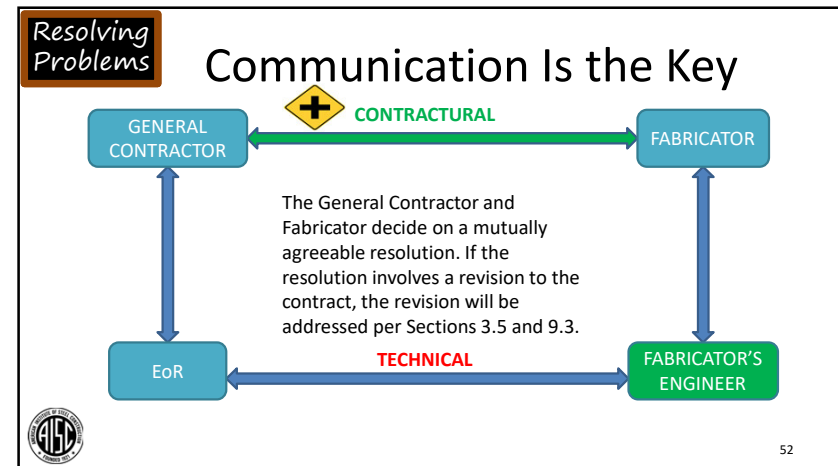
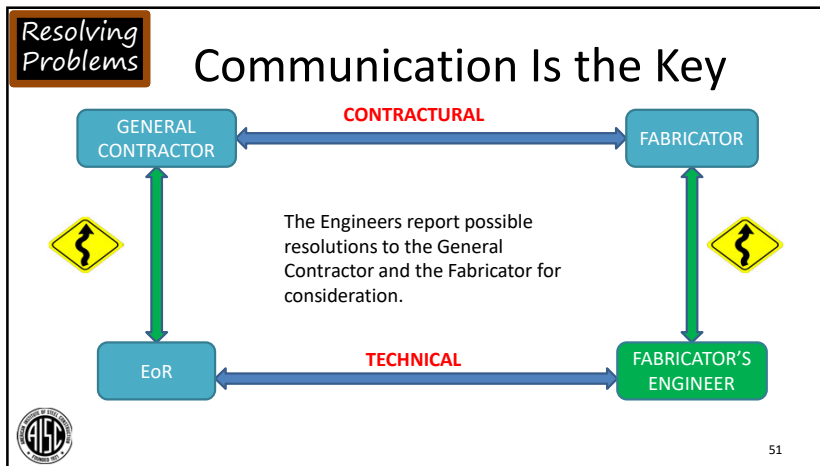
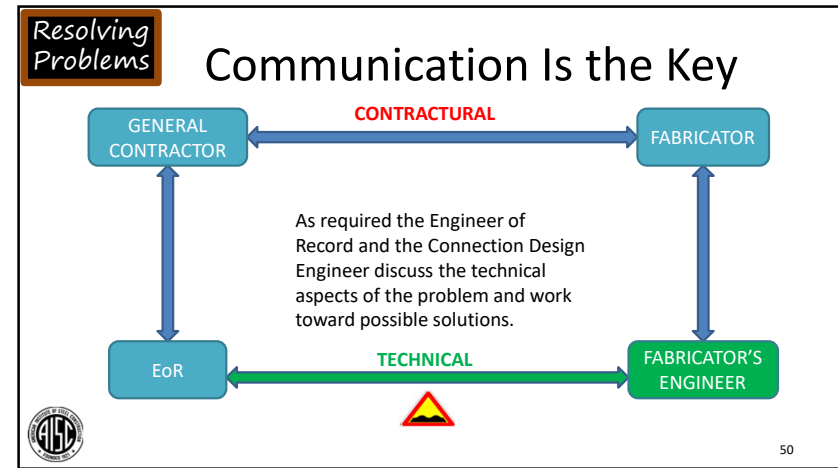
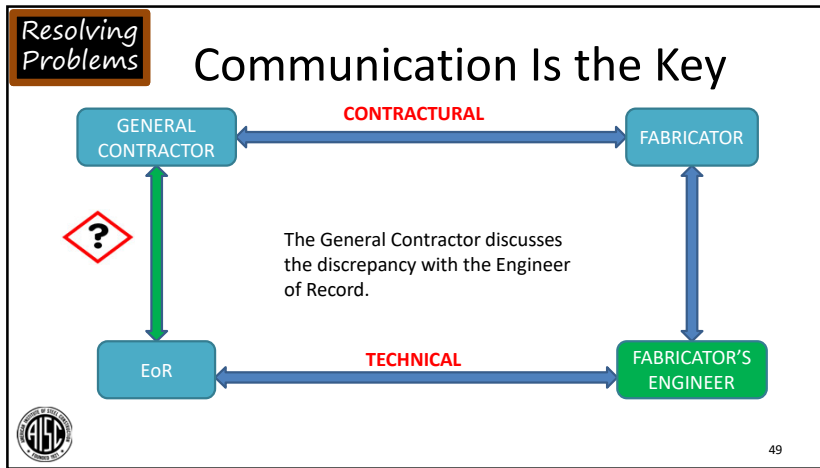

Vigilance

Vigilance

Acting or not acting on the situation

- Verify do not assume
- Most people want to do a good job – Assume the best
- Approach controversies
 - As potential misunderstandings
 - An opportunity to learn
 - An opportunity to educate





53

Vigilance

Vigilance

Acting or not acting on the situation

- Try to keep commercial and technical issue separate
- Be willing and able to defend your design decisions
- Accept that you may not have perfect information.



54

When should connections be delegated?

1. When most aspects of the design are commonplace and non-controversial such that the various options are essentially interchangeable. (i.e. standard shear connections and vertical brace and moment connections in relatively straightforward structures).
2. There are aspects of the design that are so complex and specialized that the delegating engineer is not qualified to perform the design.



55

When should connections be delegated?

1. Commonplace and Non-Controversial
 - The delegating engineer is treating the delegated design as means and methods.
 - As long as the delegated engineer is reasonably competent and is following well-established methods, then the designs should be fine.



56

When should connections be delegated?

2. Complex and Specialized

- The delegating engineer has decided that there are aspects of the delegated design that are beyond what the delegating engineer's expertise.
- Why would the delegating engineer object to things that are not within his or her expertise?



57

When should connections be delegated?

- In ALL cases the engineer of record has an obligation to assess the capability and performance of the delegated engineer (to review and approve the work).
- There will nearly always be some back-and-forth between the delegating and the delegated engineers.



58

When should connections be delegated?

- In my experience "issues" related to delegated design are most likely to become "problems" when items fall between Categories 1 and 2 are delegated.
 - Where options are NOT essentially interchangeable
 - Decisions tend to have greater effect on the structural performance of the building than the cost of the construction.
 - There may not be well-established design methods.



In my opinion such items should not be delegated because there is just too much probability that controversies will exist.⁵⁹

When should connections be delegated?

If the EoR is going to question *everything* then:

1. Delegate only TASKS using CoSP Option 2 by clearly defining design procedures and requirements

OR

2. Use CoSP Option 1



60

Vigorous Debate

- The delegated connection engineer should be prepared to vigorously defend design decisions using rational methods.
- The delegating engineer should be prepared to evaluate a vigorous defense using rational methods – when questioning the design decisions of the delegated connection engineer.
- When not done properly delegating connection design can increase everyone's workload.



61

Vigorous Debate

“A manly assertion by each of his individual rights, and a manly concession of equal right to every other man, is the boast and the law of good citizenship.”

~~~ Benjamin Harrison

Be assertive, respectful, proud and humble.  
Willing to teach and to learn.



62

## Providing Loads



63

What  
forces?

## Providing Forces

Whether the connection design will be handled by the EOR or delegated to another party, the clear and accurate communication of connection design forces is essential.

The Code of Standard Practice requires the EoR to provide, “...loads... sufficient to allow the selection, completion, or design of the *connection* details...”



64

What  
forces?

## Providing Forces

The CoSP does not require the fabricator to be provided with all of the loads, or even loads that satisfy equilibrium.

It merely requires that *sufficient* information be provided.

For other than the simplest of conditions, everyone's life is easier if the fabricator is provided with loads that satisfy equilibrium or at least that make sense.



65

What  
forces?

What Forces?

- Common forces from analysis
  - Beam end vertical shears
  - Member axial loads (tension and compression - incl. transfer forces)
  - Moments
- Less Common forces from analysis
  - Beam end horizontal shears
  - Torsion

66

What  
forces?

## Providing Forces

Providing actual forces rather than envelope (maximum) forces or written instructions will in most cases provide more economical connections and will also minimize misunderstandings.

- The use of actual forces is recommended.
- Envelop forces can be useful.
- Written instruction are often subject to miscommunication.



67

What  
forces?

## Reporting Shear Loads



68

**What forces?** Common Contract Language for Shear Connections

- All shear connections shall contain the maximum possible number of rows of bolts;
- Design all shear connections for  $\frac{1}{2}$  UDL;
- Design all shear connections for the shear capacity of the beam;
- Minimum design loads (ASD) for standard rolled shapes, unless noted otherwise.

|         |         |     |          |
|---------|---------|-----|----------|
| W8 C8   | 10 kips | W21 | 65 kips  |
| W10 C10 | 15 kips | W24 | 75 kips  |
| W12 C12 | 25 kips | W27 | 90 kips  |
| W14 C15 | 35 kips | W30 | 125 kips |
| W16     | 45 kips | W33 | 140 kips |
| W18     | 55 kips | W36 | 175 kips |



69

**What forces?** Do Not Require Design Based On UDL  
(Maximum Uniformly Distributed Load the Beam Can Support)

Overestimation (From Part 2 of the Manual):

- When beams are selected for serviceability considerations or for shape repetition, the uniform load tables will often result in heavier connections than would be required by the actual design loads.
- When beams have relatively short spans, the uniform load tables will often result in heavier connections than would be required by the actual design loads....



70

**What forces?** Do Not Require Design Based On UDL  
(Maximum Uniformly Distributed Load the Beam Can Support)

Underestimation (From Part 2 of the Manual):

- When beams support other framing beams or other concentrated loads occur on girders supporting beams, the end reactions can be higher than 50% of the total uniform load.
- For composite beams, the end reactions can be higher than 50% of the total uniform load. The percentage requirement can be increased for this condition, but the resulting approach is still subject to the above considerations.



71



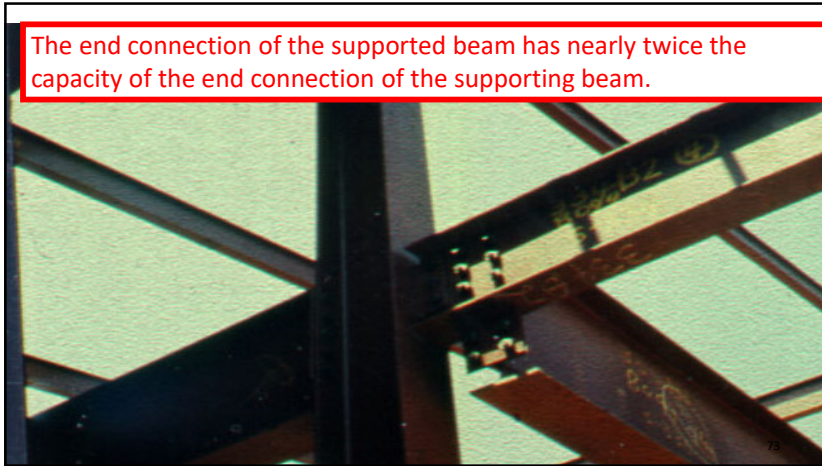

**What forces?**

## How Not to Handle Short Span Beams



75

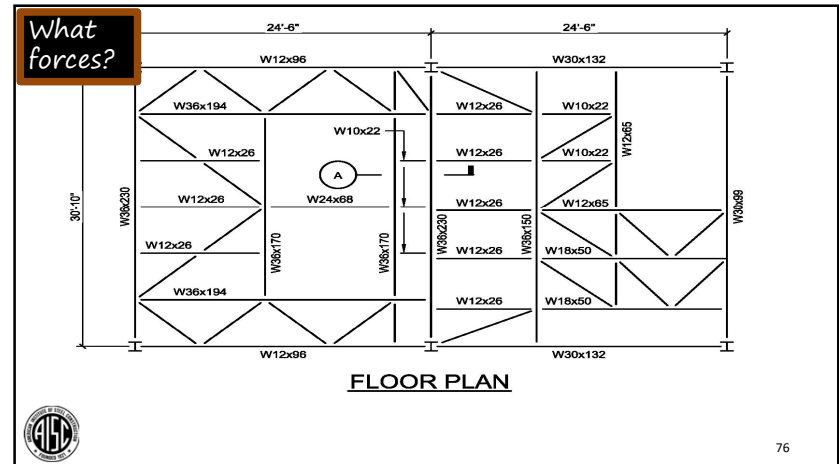

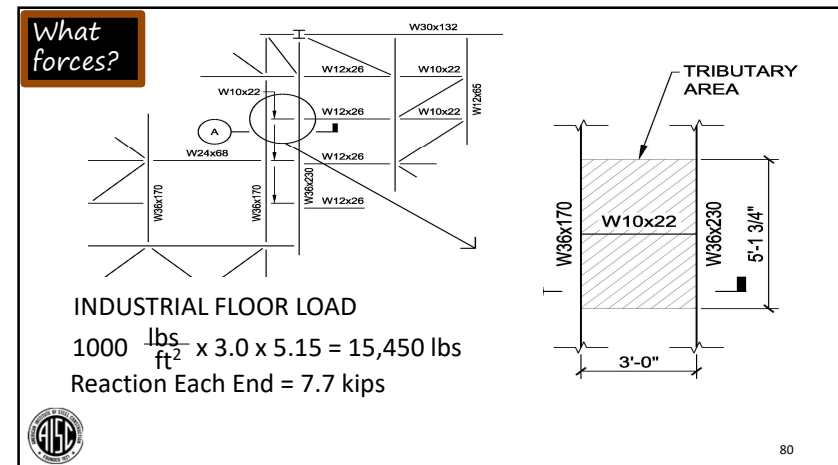
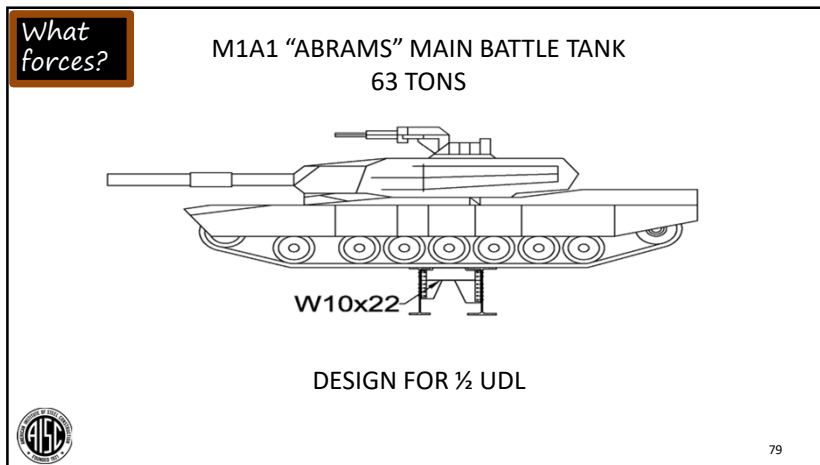
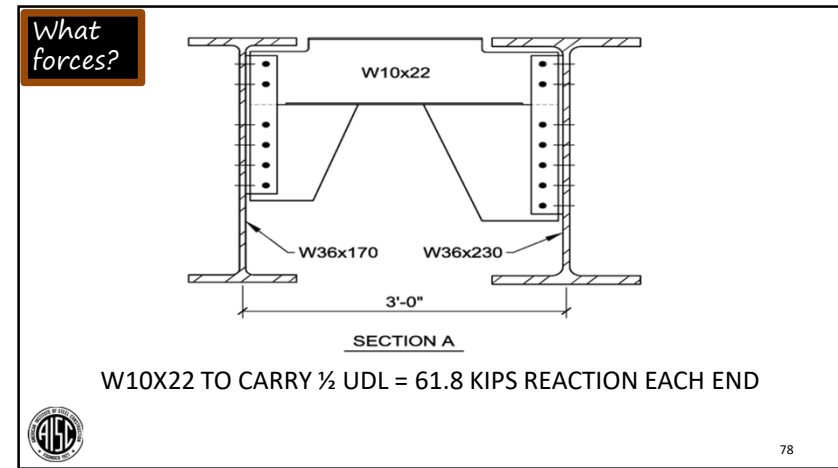
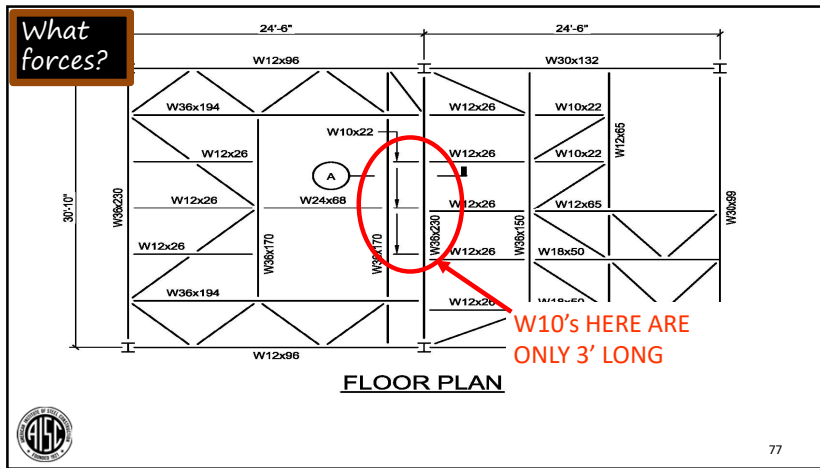

**What forces?** Reporting Vertical Brace Loads



81

**What forces?** Reporting Vertical Brace Loads

- Provide actual loads. Do not require connections to develop the strength of the brace.
- Provide both tension and compression loads
  - Some limit states may apply to only one condition (block shear, buckling) and could affect the final design.
- Provide Transfer Force



82

**What forces?** Reporting Transfer Forces

Good resources available from AISC:

- Design Guide 29, Appendix D ([aisc.org/dg](http://aisc.org/dg) – free download for AISC members)
- Demystifying Connection Design and Transfer Forces [N59A] ([aisc.org/educationarchives](http://aisc.org/educationarchives) – free to view)



83

**What forces?** Transfer Forces

- The term Transfer Force is not defined in the glossary for either the *Code of Standard Practice* or the *Specification for Structural Steel Buildings*.
- A possible definition: A force that must be transferred from one element to another through connection elements and whose magnitude and direction cannot be ascertained from the maximum member end forces.



84

**What forces?**

## Transfer Forces



- A transfer force is not the member force (the axial load in the member).
- The transfer forces usually are not reported by structural analysis software – though it can be.
- Transfer forces depend on connection configuration.



85

**What forces?**

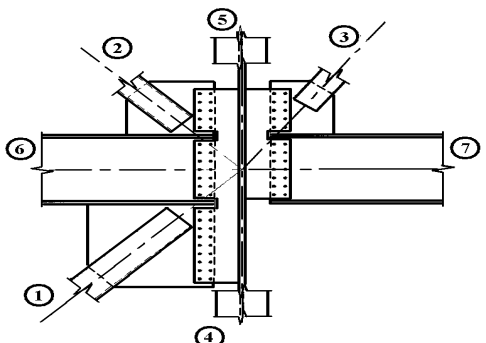

## Transfer Forces

86

**What forces?**

## Transfer Forces

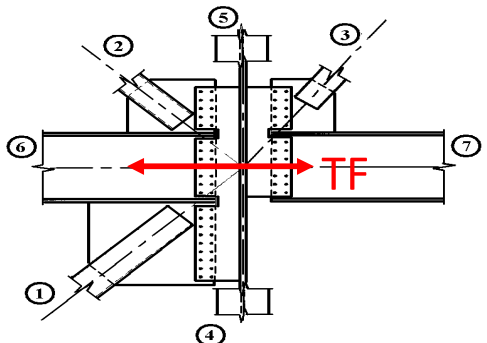

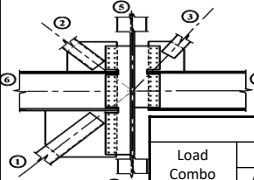

87

**Transfer Forces**



| Load Combo                               | Member ID |         |         |         |         |         |         | TF    |
|------------------------------------------|-----------|---------|---------|---------|---------|---------|---------|-------|
|                                          | Axial 1   | Axial 2 | Axial 3 | Axial 4 | Axial 5 | Axial 6 | Axial 7 |       |
| 1                                        | -509      | 217     | -198    | -125    | -479    | 120     | 30.2    | -86.7 |
| 2                                        | 366       | -386    | 113     | -867    | -426    | 24.9    | -55.6   | 10.9  |
| 3                                        | 323       | -436    | 87.6    | -1160   | -697    | 68.2    | -63.4   | -11.6 |
| 4                                        | -466      | 267     | -173    | 170     | -209    | 76.8    | 38      | -64.1 |
| 5                                        | -185      | -219    | -50.3   | -1130   | -1070   | 194     | -62     | -91.6 |
| 6                                        | 41.6      | 50.3    | -34.8   | 145     | 167     | -49     | 36.5    | 16.0  |
| Transfer Forces – Based on Maximum Loads |           |         |         |         |         |         |         |       |
| Max. C                                   | 509       | 436     | 198     | -       | -       | 49      | 63.4    | 717   |
| Max. T                                   | 366       | 267     | 113     | -       | -       | 194     | 36.5    | 620   |



**What forces?**

### Transfer Forces

89

**What forces?**

### Transfer Forces

90

**What forces?**

### Reporting Moment Connection Loads

91

**What forces?**

### Reporting Moment Connection Loads

- Provide actual loads. Do not require connections to develop the strength of the member.
- Provide both lateral and gravity moments.

92

The  
Future

## In the Not Too Distant Future

The 2022 Specification will likely include requirements for design drawings and approvals that have historically been addressed in the Code of Standard Practice.

Communication of design requirements, review and approval are directly related to ensuring safety.



93

The  
Future

## Warning Signs???

Computers have increased productivity and freed engineers from much of the drudgery of tedious calculations but have also tended to put distance between engineers and their designs.

“Fast track” projects have become increasingly popular but complicate communication.

These factors and others have changed the role of engineers in our industry and have subjected them to tremendous pressures.



The  
Future

## Warning Signs???

In my mind the 2022 changes were put in place to require some engineers (who might do otherwise) to conform to acceptable standards of engineering ethics and to make available to most engineers (who want to do the right thing) a defense against mounting pressures to do the wrong thing.

It is a Band-Aid.

“I'm worried about you; I'm worried about me.  
The curves around midnight aren't easy to see.”  
~~~~ John Stewart



The
Future

Warning Signs???

There is some lower limit to both the amount of work and responsibility involved with structural projects.

Various means can be used to try to move these factors around, but one should not assume that they can be made to disappear.

They do not.

“There ain't no free lunch.”



96

The Future

Warning Signs???

These comments are included because they are important.

They are not easily addressed and cannot be addressed sufficiently in this Night School.

However, it seemed irresponsible not to communicate them in some form for your consideration.



 97

The Future

Problems Brewing???



To prevent problems you must:

1. Observe the potential problem.
2. Understand the significance.
3. Act.

In our industry acting involves communication.

Effective communication takes time. Take the time to communicate.

 "The time is always right to do the right thing."
~~~ Martin Luther King Jr. 98

## OH NO!!! HOMEWORK!!!

Read:

- *Specification* Section B1 & its Commentary
- *Specification* Section B3.4 & its Commentary
- Chapter 1 of Design Guide 29

Continue to submit questions and topics of interest to you via the chat or [nightschool@aisc.org](mailto:nightschool@aisc.org).

 99

# Thank you!

AISC | Questions



Smarter.  
Stronger.  
Steel.

## Individual Session Registrants

### PDH Certificates

- All WFH individuals associated with a group registration will be issued a certificate.
- All individuals attending at your connection: you will receive an email on how to report their attendance from: [registration@aisc.org](mailto:registration@aisc.org).
  - Be on the lookout: Check your spam filter! Check your junk folder!
  - Completely fill out online form. Don't forget to check the boxes next to each attendee's name!



## 8-Session Registrants

### PDH Certificates

One certificate will be issued at the conclusion of all 8 sessions.



## 8-Session Registrants

### Access to the quiz

Information for accessing the quiz will be emailed to you by Thursday. It will contain a link to access the quiz. EMAIL COMES FROM [NIGHTSCHOOL@AISC.ORG](mailto:NIGHTSCHOOL@AISC.ORG).

### Quiz and attendance records

Posted Thursday mornings. [www.aisc.org/nightschool](http://www.aisc.org/nightschool) -- Click on Current Course Details.

### Reasons for quiz

- EEU – You must take all quizzes and the final exam to receive EEU.
- PDHs – If you watch a recorded session, you must pass quiz for PDHs.
- REINFORCEMENT – Reinforce what you learn tonight. Get more out of the course.

*Note: If you attend the live presentation, you do not have to take the quizzes to receive PDHs*



## 8-Session Registrants

### Access to the recording

Information for accessing the recording will be emailed to you by Thursday. The recording will be available for four weeks. (For 8-session registrants only.) EMAIL COMES FROM [NIGHTSCHOOL@AISC.ORG](mailto:NIGHTSCHOOL@AISC.ORG).

### PDHs via recording

If you watch a recorded session, you must take *and pass* the quiz for PDHs.



## 8-Session Registrants

### Night School Resources

Find all your handouts, quizzes and quiz scores, recording access, and attendance information all in one place!



## 8-Session Registrants

### Night School Resources

Go to [www.aisc.org](http://www.aisc.org) and sign in.

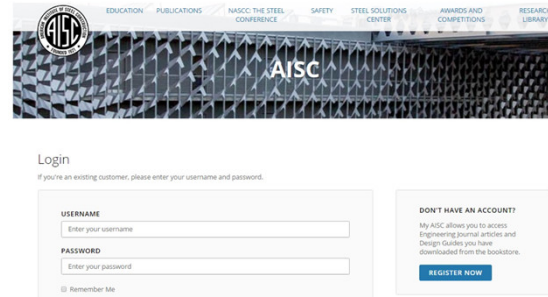

## 8-Session Registrants

### Night School Resources

Go to [www.aisc.org](http://www.aisc.org) and sign in.

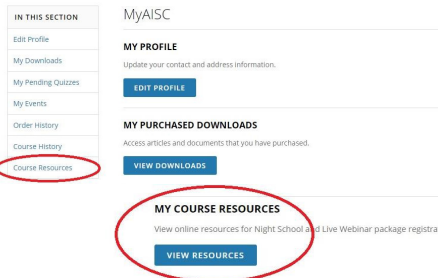

## 8-Session Registrants

### Night School Resources

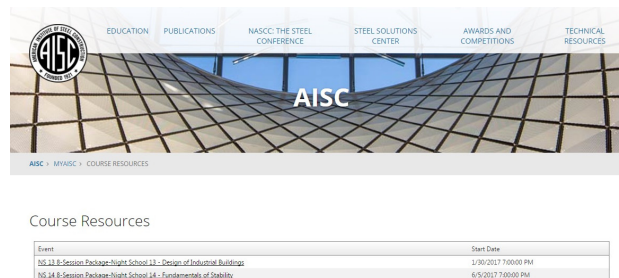

## 8-Session Registrants

### Night School Resources

| Event                                                        | Date                 | Handouts                 | Videos                 | Quiz                         | Attendance |
|--------------------------------------------------------------|----------------------|--------------------------|------------------------|------------------------------|------------|
| NS13 - Design Criteria                                       | 1/30/2017 7:00:00 PM | <a href="#">Handouts</a> | <a href="#">Videos</a> | Final Score: 80              | Pending    |
| NS13 - Economic Considerations                               | 2/6/2017 7:00:00 PM  | <a href="#">Handouts</a> | <a href="#">Videos</a> | Available 02/08/2017 5pm EST | Pending    |
| NS13 - Lateral Load Systems and Details                      | 2/13/2017 7:00:00 PM | <a href="#">Handouts</a> | <a href="#">Videos</a> | Available 02/15/2017 5pm EST | Pending    |
| NS13 - Preliminary Design Procedures                         | 2/27/2017 7:00:00 PM | <a href="#">Handouts</a> | <a href="#">Videos</a> | Available 03/01/2017 5pm EST | Pending    |
| NS13 - Core Girder Design and Frame Analysis                 | 3/6/2017 7:00:00 PM  | <a href="#">Handouts</a> | <a href="#">Videos</a> | Available 03/08/2017 5pm EST | Pending    |
| NS13 - Frame Member and Connection Design                    | 3/13/2017 7:00:00 PM | <a href="#">Handouts</a> | <a href="#">Videos</a> | Available 03/15/2017 5pm EST | Pending    |
| NS13 - Transfer Crane Girder & Longitudinal Brag Bracing Den | 3/27/2017 7:00:00 PM | <a href="#">Handouts</a> | <a href="#">Videos</a> | Available 03/29/2017 5pm EST | Pending    |
| NS13 - Building Envelope and Bracing Design                  | 4/3/2017 7:00:00 PM  | <a href="#">Handouts</a> | <a href="#">Videos</a> | Available 04/05/2017 5pm EST | Pending    |

## 8-Session Registrants

### Night School Resources

- Weekly “quiz and recording” email.
- Weekly updates of the master quiz and attendance record, found at [www.aisc.org/nightschool26](http://www.aisc.org/nightschool26). Scroll down to Quiz and Attendance records.
  - Updated on Friday mornings.



## 8-Session Registrants

### Night School Resources

- Webinar connection information
  - Reminder email sent out Tuesday mornings
- Links to handouts also found here



AISC | Thank you



Smarter.  
Stronger.  
Steel.