



**Night School 27:  
Fundamentals of  
Welding and Bolting**

Thank you for joining our live webinar. We will begin shortly. Please standby.

**AISC  
Night School**



**Session 1 – Introduction and Welding Processes**  
September 27, 2021 | Curtis Decker



**Smarter.  
Stronger.  
Steel.**

## AISC Live Webinars

**Today's live webinar will begin shortly. Please stand by.**

Today's audio will be broadcast through the internet. Please be sure to turn up the volume on your speakers.

Please type any questions or comments in the Q&A window.



## AISC Live Webinars

### AIA Credit

AISC is a Registered Provider with The American Institute of Architects Continuing Education Systems (AIA/CES). Credit(s) earned on completion of this program will be reported to AIA/CES for AIA members. Certificates of Completion for both AIA members and non-AIA members are available upon request.

This program has been submitted for AIA/CES for continuing professional education. As such, it does not include content that may be deemed or construed to be an approval or endorsement by the AIA of any material of construction or any method or manner of handling, using, distributing, or dealing in any material or product.

Questions related to specific materials, methods, and services will be addressed at the conclusion of this presentation.



## AISC Live Webinars

### Copyright Materials

This presentation is protected by US and International Copyright laws. Reproduction, distribution, display and use of the presentation without written permission of AISC is prohibited.

© The American Institute of Steel Construction 2021

The information presented herein is based on recognized engineering principles and is for general information only. While it is believed to be accurate, this information should not be applied to any specific application without competent professional examination and verification by a licensed professional engineer. Anyone making use of this information assumes all liability arising from such use.



## AISC Live Webinars

### Course Description

#### NS27.1 – Welding Part 1 Introduction and Welding Processes September 27, 2021

This session will consist of a review of applicable welding codes, the basics of welded joints and weld types, and required weld metal strength levels. Details for welded connection details will be discussed, including the basic criteria to be used to determine weld throat dimensions.



## AISC Live Webinars

### Learning Objectives

- Identify standards related to welding.
- Compare and contrast various arc welding processes.
- Define various welding and thermal cutting processes.
- Compare and contrast various joints and weld types.



## Night School 27: Fundamentals of Welding and Bolting



Curtis L. Decker, PhD, PE,  
SE, The Lincoln Electric  
Company



Duane K. Miller, PE, ScD,  
The Lincoln Electric  
Company



Chad Larson, LeJeune  
Bolt Company



## Night School 27: Fundamentals of Welding and Bolting

### Welding Part 1: Introduction and Welding Processes September 27, 2021

Curtis L. Decker, PhD, PE, SE, The Lincoln Electric Company



AISC Design Guide 21, 2<sup>nd</sup> Edition

**Welded Connections—  
A Primer for Engineers**

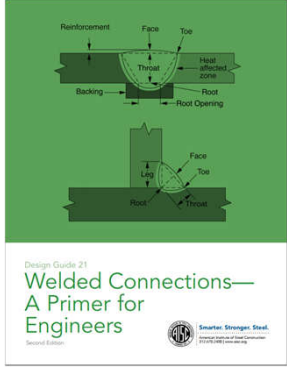

Design Guide 21  
**Welded Connections—  
A Primer for Engineers**  
Second Edition

Smarter. Stronger. Steel.  
American Institute of Steel Construction, Inc.  
1110 North Dearborn Street  
Chicago, IL 60610-6401  
www.aisc.org





10

**WELDED CONNECTIONS—A PRIMER FOR ENGINEERS**

**Chapter 1: Introduction**

- 1.1 Importance of Welding
- 1.2 Scope of Welding
- 1.3 Welding-Related Codes and Specifications





10

**WELDED CONNECTIONS—A PRIMER FOR ENGINEERS**

**Chapter 2: Welding and Thermal Cutting Processes**

- 2.1 Introduction
- 2.2 SMAW
- 2.3 FCAW
- 2.4 SAW
- 2.5 GMAW
- 2.6 ESW/EGW
- 2.7 GTAW





11

**WELDED CONNECTIONS—A PRIMER FOR ENGINEERS**

**Chapter 2: Welding and Thermal Cutting Processes**

- 2.8 Arc Stud Welding
- 2.9 Thermal Cutting Processes
- 2.10 Water Jet Cutting



12

**WELDED CONNECTIONS—A PRIMER FOR ENGINEERS**

**Chapter 3: Welded Connection Basics**

- 3.1 Joints
- 3.2 Weld Types—General
- 3.3 Complete-Joint-Penetration Groove Welds
- 3.4 Partial-Joint-Penetration Groove Welds
- 3.5 Fillet Welds
- 3.6 Plug/Slot Welds
- 3.7 Puddle Welds



13

**WELDED CONNECTIONS—A PRIMER FOR ENGINEERS**

**Chapter 3: Welded Connection Basics**

- 3.8 Interaction of Joint Types and Weld Types
- 3.9 Selection of Weld Types
- 3.10 Required Filler Metal Strength
- 3.11 Determining Weld Strength
- 3.12 Specific Requirements for Various Joints
- 3.13 Weld Symbols



14

**WELDED CONNECTION BASICS**

**Outline**

- Applicable Codes
- Arc Welding Processes – Overview
- Welding and Thermal Cutting Processes
- Joints and Weld Types



15

**WELDED CONNECTION BASICS**

**Outline**

- ➔ • Applicable Codes
- Arc Welding Processes – Overview
- Welding and Thermal Cutting Processes
- Joints and Weld Types



16

**AWS D1.1**  
Structural Welding Code –  
Steel

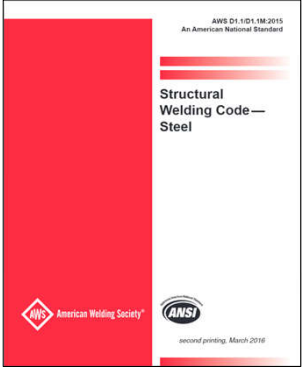

17

**AWS D1.1: 2020 Structural Welding Code – Steel**

**Major sections of AWS D1.1 include the following:**

- Clause 1 – General Requirements
- Clause 2 – Normative References
- Clause 3 – Terms and Definitions
- Clause 4 – Design of Welded Connections
- Clause 5 - Prequalification of WPSs
- Clause 6 - Qualification



18

**AWS D1.1: 2020 Structural Welding Code – Steel**

**Major sections of AWS D1.1 include the following:**

- Clause 7 – Fabrication
- Clause 8 – Inspection
- Clause 9 – Stud Welding
- Clause 10 – Tubular Structures
- Clause 11 – Strengthening and Repair of Existing Structures



19

**AWS D1.3**  
Structural Welding Code –  
Sheet Steel

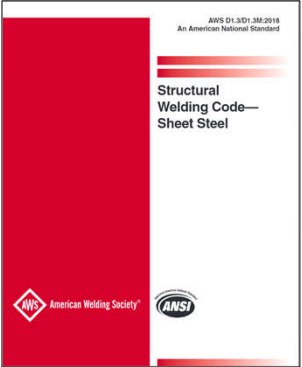



20

**AWS D1.3: 2018 Structural Welding Code – Sheet Steel**

**AWS D1.3 covers:**

- Welding of structural sheet and strip steels, including cold-formed members equal to or less than 3/16 in. [5mm] thick.
- The primary purpose for structural steel applications: welding sheet steel decking to supporting members with puddle welds.



21

**AWS D1.4**

Structural Welding Code –  
Steel Reinforcing Bars

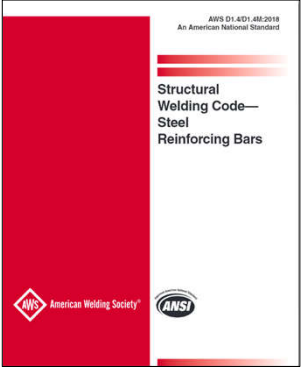

22

**AWS D1.4: 2018 Structural Welding Code – Steel Reinforcing Bars**

**AWS D1.4 covers:**

- Welding of reinforcing steel (rebar) to itself
- Welding of rebar to plate or shapes, including embed plates and steel used in composite construction



23

**AASHTO/AWS D1.5**

Bridge Welding Code

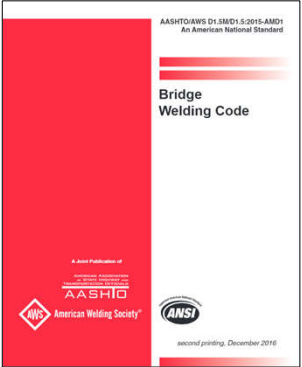



24

**AASHTO/AWS D1.5: 2020 Bridge Welding Code**

**AASHTO/AWS D1.5:**



- Joint standard of the AWS and the American Association of State Highway Transportation Officials (AASHTO)
- Generally requires that WPS be qualified by test, with a few exceptions
- Qualification testing involves Charpy V-notch (CVN) specimens and all weld metal tensile specimens
- Nondestructive testing (NDT) requirements



25

**AWS D1.6**

Structural Welding Code –  
Stainless Steel





26

**AWS D1.6: 2017 Structural Welding Code – Stainless Steel**

**AWS D1.6 covers:**



- Requirements for welding various grades of stainless to stainless, as well as stainless to carbon steel



27

**AWS D1.7**

Guide for Strengthening and Repairing  
Existing Structures





28

**AWS D1.7: 2010 Guide for Strengthening and Repairing Existing Structures**

**AWS D1.7:**



- D1.1 requires the Engineer to “establish a comprehensive plan for the work”: D1.7 can provide guidance
- Not a code, but a guide
- Provides guidance on: weldability, evaluation of existing welds, testing and sampling, heat strengthening, strengthening and damage repair



29

**AWS D1.8**

Structural Welding Code –  
Seismic Supplement





30

**AWS D1.8: 2016 Structural Welding Code – Seismic Supplement**

**AWS D1.8:**

- Supplements AWS D1.1
- When AWS D1.8 is specified, all the provisions of AWS D1.1 still apply, unless modified or superseded by AWS D1.8
- Assumes that the structure is designed with AISC *Seismic Provisions*



31

**AISC 360-16**

Specification for Structural Steel  
Buildings

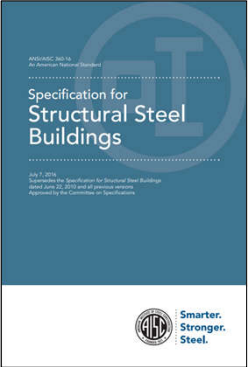



32

**AISC 360-16 Specification for Structural Steel Buildings**

**AISC 360 addresses the following major welding-related items:**

- Acceptable steel designations (Section A3.1)
- Acceptable filler metals (Section A3.5)
- Requirements for splices in heavy sections (Section J1.5)
- Beam copes and weld access holes (Section J1.6)
- Welds in combination with bolts (Section J1.8)
- Details of groove welds (Section J2.2)
- Details of fillet welds (Section J2.2)





33

**AISC 360-16 Specification for Structural Steel Buildings**

**AISC 360 addresses the following major welding-related items:**

- Available strength of welded joints (Table J2.5)
- Shop fabrication/welding issues (Section M2)
- Field erection/welding issues (Section M4)
- Weld quality control and quality assurance issues (Chapter N)
- Weld details for fatigue (Appendix 3)
- Welding issues associated with existing structures (Appendix 5)



34

**AISC 341-16**

Seismic Provisions for Structural Steel Buildings

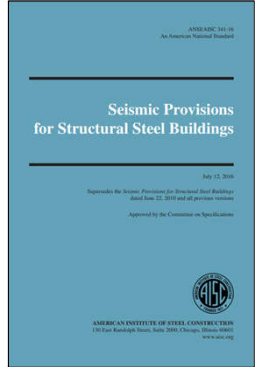



35

**AISC 341-16 Seismic Provisions for Structural Steel Buildings**

**AISC 341:**

- Developed to augment the AISC *Specification*
- Adds provisions deemed necessary for high-seismic applications, where steel members are required to dissipate energy through controlled inelastic deformations in major seismic events
- For welding-related issues, primarily refers to D1.8
- Contains “grocery list” of items to be specified in contract documents, including many welding-related issues



36

**AISC 358-16**

Prequalified Connections for Special and Intermediate Steel Moment Frames for Seismic Applications

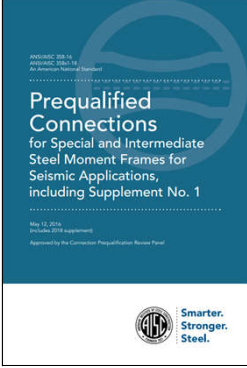

37

**AISC 358-16 Prequalified Connections for Special and Intermediate Steel Moment Frames for Seismic Applications**

**AISC 358:**

- Specifies design, detailing, fabrication, and quality criteria for connections that are prequalified in accordance with AISC *Seismic Provisions*
- For use with special moment frames (SMF) and intermediate moment frames (IMF)
- For welding-related issues, primarily refers to AISC 341
- Some prequalified connections have unique welded detail requirements (WUF-W, Endplate)



38

**AISC 303-16**

Code of Standard Practice for Steel Buildings and Bridges



39

**AISC 303-16 Seismic Provisions for Structural Steel Buildings**

**AISC 303 addresses these major welding-related issues:**

- Overall tolerances of fabricated members and erected assemblies
- Basic tolerances for architecturally exposed structural steel (AESS)



40

**Welding-Related Codes and Specifications**

**Other AWS D1 Codes:**

- AWS D1.2/D1.2M *Structural Welding Code — Aluminum*
- AWS D1.9/D1.9M *Structural Welding Code — Titanium*





41

**Welding-Related Codes and Specifications**

**Other AWS Standards:**

- AWS A5 *Filler Metal Specifications*
- AWS A2.4 *Standard Symbols for Welding, Bracing, and Nondestructive Examination*
- AWS A3.0/A3.0M *Standard Welding Terms and Definitions*



42

**WELDED CONNECTION BASICS**

**Outline**

- Applicable Codes
- ➔ • Arc Welding Processes – Overview
- Welding and Thermal Cutting Processes
- Joints and Weld Types





43

**AWS STANDARD WELDING TERMS & DEFINITIONS (A3.0:2010)**

**weld.**

A localized coalescence of metals or nonmetals produced by heating the materials to the welding temperature, with or without the application of pressure, or by the application of pressure alone and with or without the use of filler metal.





44

### Arc Welding Processes

**Requirements for fusion:**

- Atomic closeness
- Atomic cleanliness



45

### Arc Welding Processes

#### Atomic Closeness

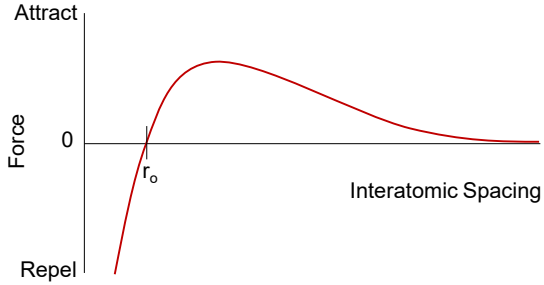

Adapted from W.F. Savage, as presented in *Weld Imperfections*, 1968



46

### Arc Welding Processes

#### Atomic Closeness

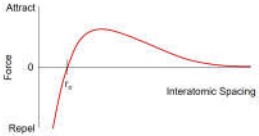
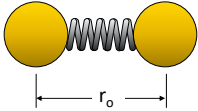

47

### Arc Welding Processes

#### Atomic Closeness

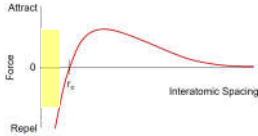
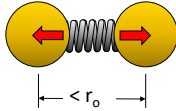

48

### Arc Welding Processes

#### Atomic Closeness

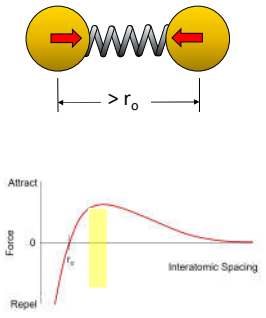

The diagram shows two yellow spheres representing atoms. A spring connects them, with red arrows pointing towards each other. Below the spheres, a horizontal line with arrows at both ends is labeled  $> r_0$ . Below this is a graph with 'Force' on the vertical axis and 'Interatomic Spacing' on the horizontal axis. The vertical axis has 'Attract' at the top, '0' in the middle, and 'Repel' at the bottom. A red curve starts in the 'Repel' region, crosses the zero line, reaches a peak in the 'Attract' region, and then levels off. A yellow vertical bar is positioned at the peak of the curve, labeled  $r_s$ .

49

### Arc Welding Processes

#### Atomic Closeness

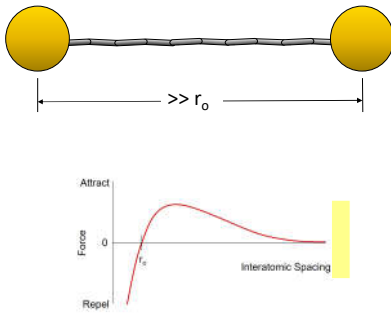

The diagram shows two yellow spheres representing atoms. A compressed spring connects them, with red arrows pointing towards each other. Below the spheres, a horizontal line with arrows at both ends is labeled  $>> r_0$ . Below this is a graph with 'Force' on the vertical axis and 'Interatomic Spacing' on the horizontal axis. The vertical axis has 'Attract' at the top, '0' in the middle, and 'Repel' at the bottom. A red curve starts in the 'Repel' region, crosses the zero line, reaches a peak in the 'Attract' region, and then levels off. A yellow vertical bar is positioned at the peak of the curve, labeled  $r_s$ .

50

### Arc Welding Processes

#### Atomic Closeness:

- Very, very close
- Gaps exist between materials, even carefully machined parts (typically 100-1000 atom diameters from peak to valley of carefully machined parts)

51

### Arc Welding Processes

#### How to Achieve Atomic Closeness:



- Melt one material (brazing, soldering)
- Melt two or more materials (arc welding, resistance welding)
- Use pressure (with or without heat) to force closeness (forge welding, friction stir welding)

52

**Arc Welding Processes**

**Atomic Cleanliness:**

- Oxides form very rapidly
- Oxides neutralize the attractive forces
- Other contaminants: water, oil, gasses





53

**Arc Welding Processes**

**How to Achieve Atomic Cleanliness:**

- Mechanically clean the part (scraping, machining)
- Chemically clean the part (fluxes)



54

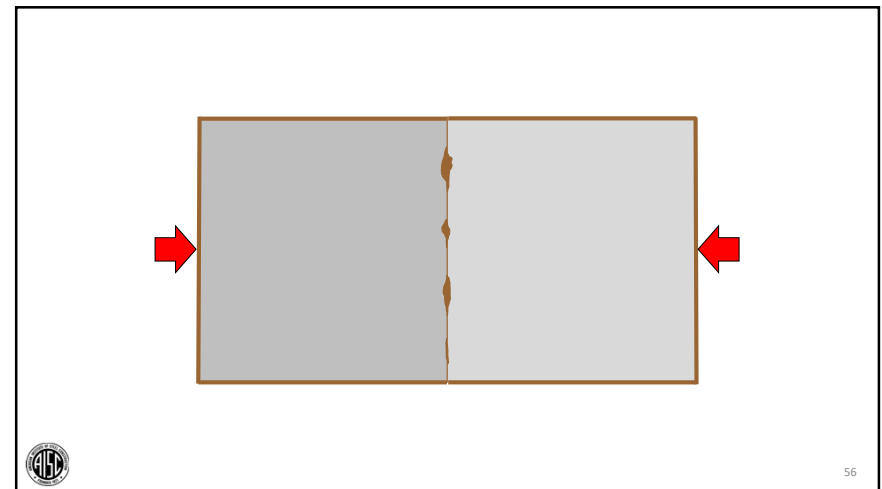
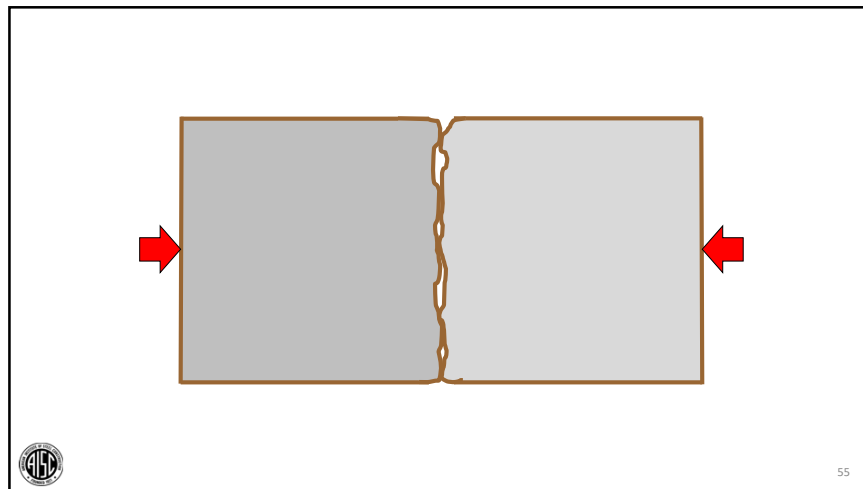

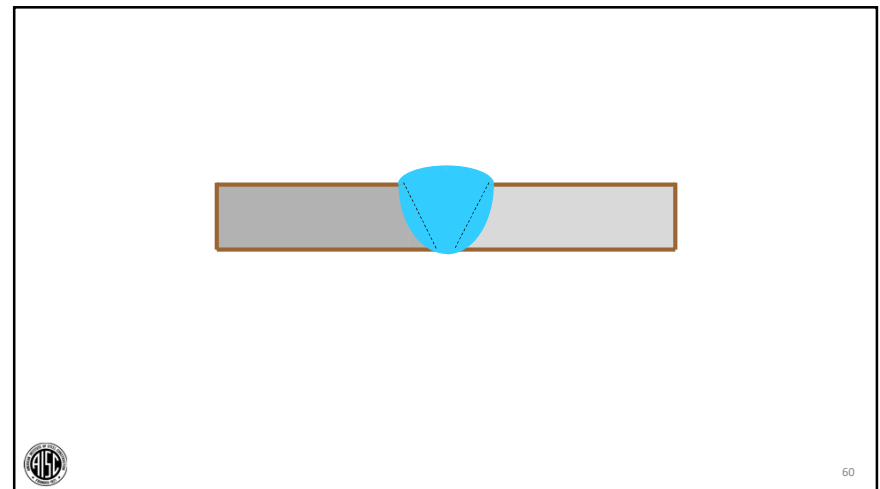
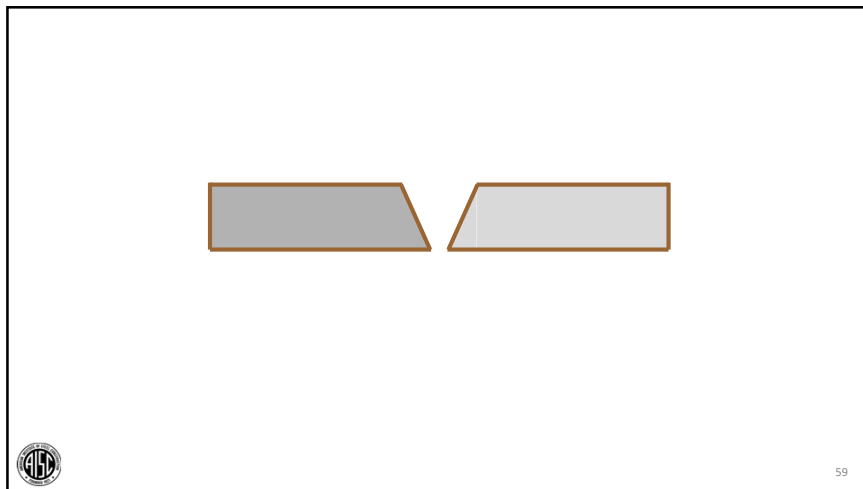
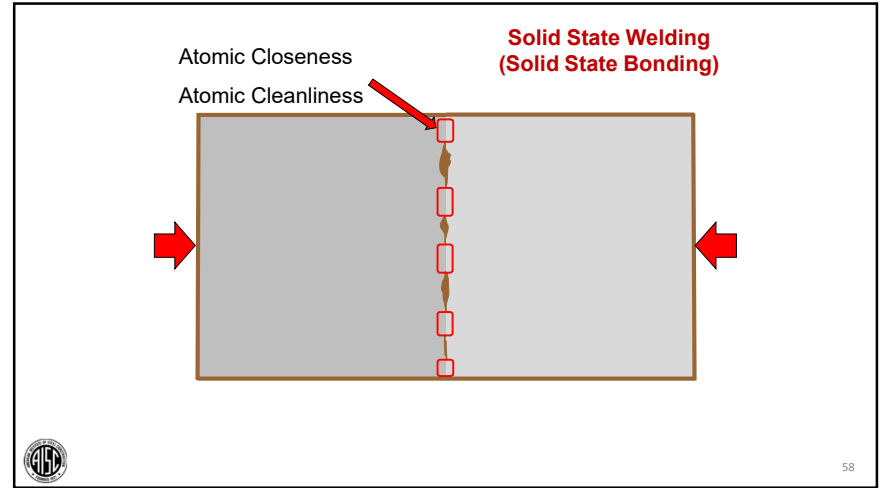
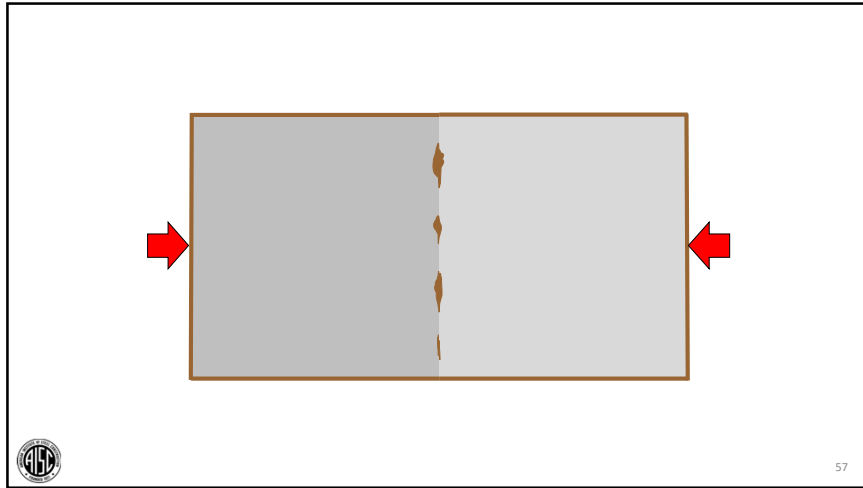

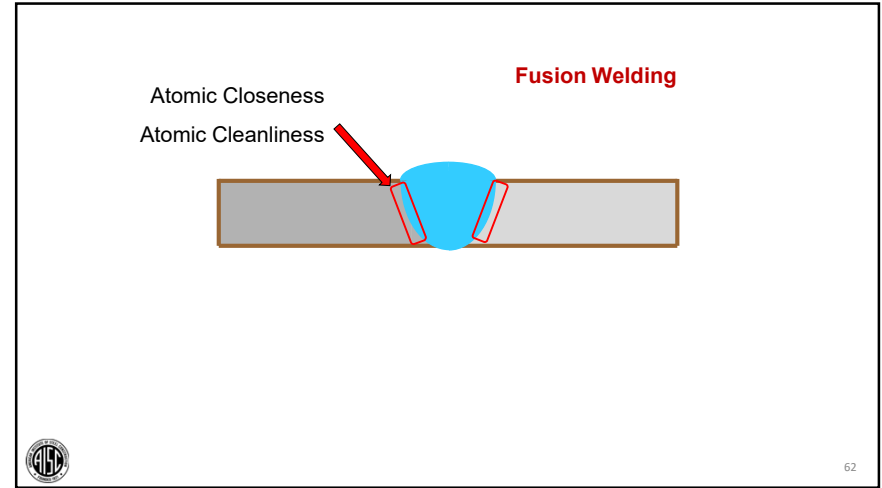
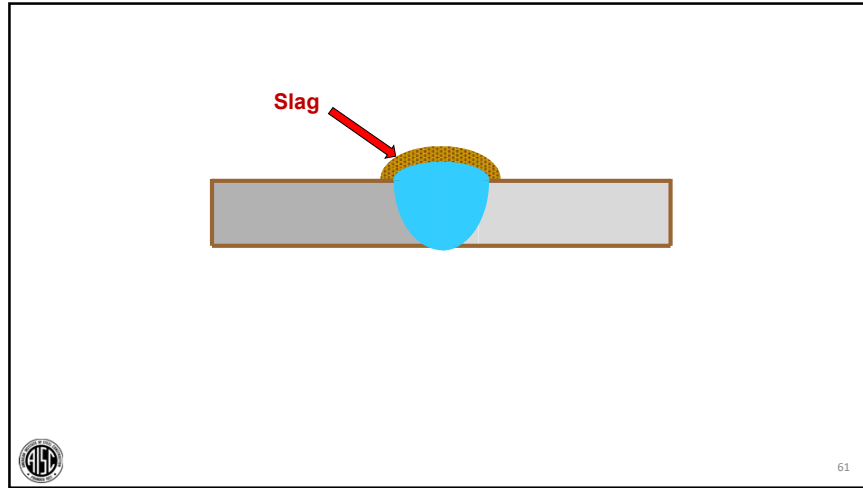



**AWS STANDARD WELDING TERMS & DEFINITIONS (A3.0:2020)**

**fusion, fusion welding.**

The melting together of filler metal and base metal, or of base metal only, to produce a weld.





63

**AWS STANDARD WELDING TERMS & DEFINITIONS (A3.0:2020)**

**arc welding.**

A group of welding processes producing coalescence of workpieces by melting them with an arc. The processes are used with or without the application of pressure and with or without filler metal.



64

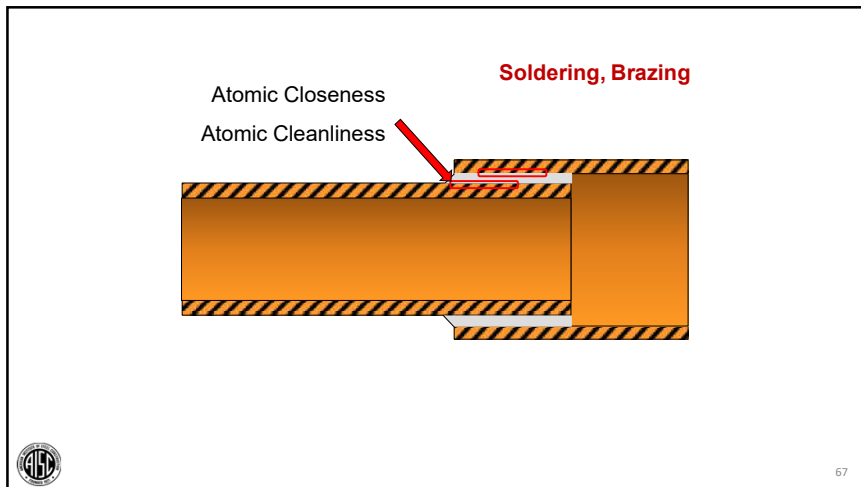
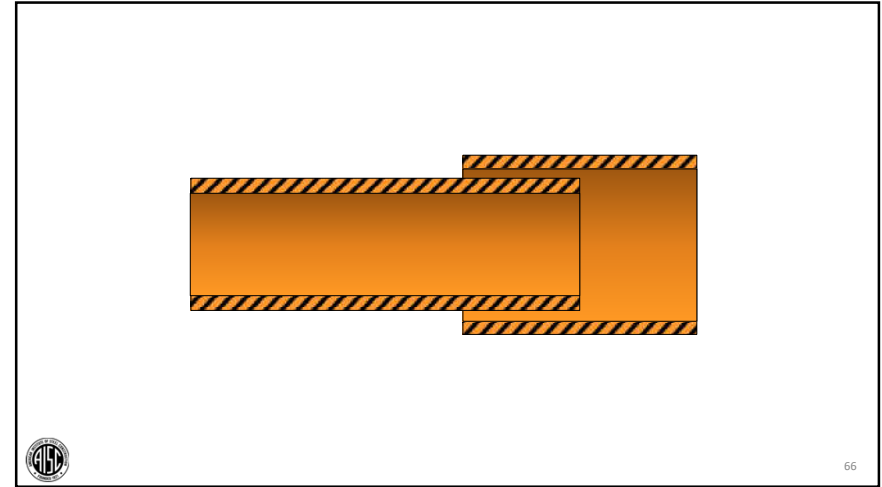
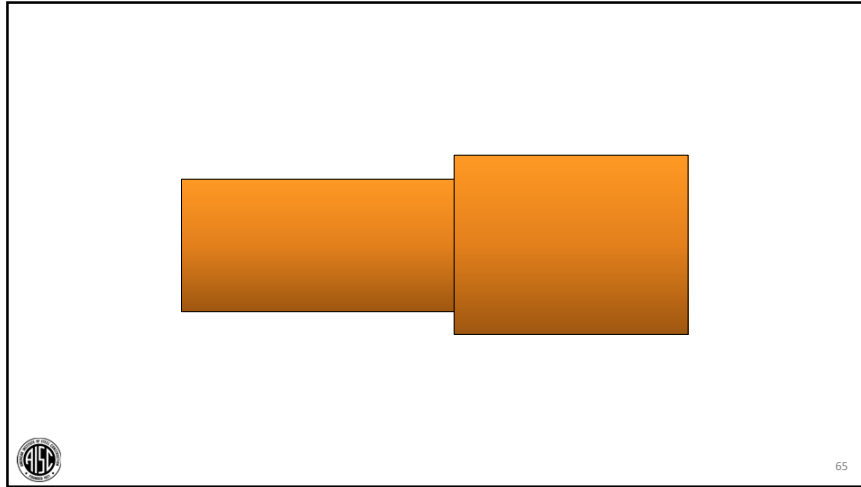

**AWS STANDARD WELDING TERMS & DEFINITIONS (A3.0:2020)**

**Soldering Filler Metal**

A filler metal having a liquidus below 450°C [840°F] to be added in making a soldered joint.





In the bottom left corner is the AISC logo, and in the bottom right corner is the number 68.

**AWS STANDARD WELDING TERMS & DEFINITIONS (A3.0:2020)**

**Brazing Filler Metal**

The filler metal to be added in making a brazed joint. The filler metal has a liquidus above 450°C [840°F] and below the solidus of the base material.





69

**Arc Welding Processes**

**How to protect the metal puddle from the atmosphere:**

- Inert gasses that displace the atmosphere
- Slags that form a mechanical barrier
- Both slags and gasses





70

**Arc Welding Processes**

**Once a puddle is formed...  
...the puddle must be protected from the atmosphere.**

- 80% Nitrogen
- 19% Oxygen

(Also, need to protect the metal droplets in the arc)





71

**Arc Welding Processes**

**Once a puddle is formed...  
...need to control the shape of the puddle.**

- Shielding gasses affect weld puddle surface tension (and the wetting of the puddle to the base metal)
- Slags can be used to support and shape weld puddles





72

### Arc Welding Processes

**Major arc welding processes:**

- Shielded Metal Arc Welding (SMAW)
- Flux Core Arc Welding (FCAW)
- Gas Metal Arc Welding (GMAW)
- Submerged Arc Welding (SAW)
- Gas Tungsten Arc Welding (GTAW)
- Electroslag Welding (ESW)
- Electrogas Welding (EGW)
- Arc Stud Welding (ASW)





73

### Arc Welding Processes

**Major thermal cutting processes:**

- Oxy-fuel Cutting (OFC)
- Plasma Arc Cutting (PAC)
- Air Arc Gouging (AAG)



74

### WELDED CONNECTION BASICS

**Outline**

- Applicable Codes
- Arc Welding Processes – Overview
- ➔ • Welding and Thermal Cutting Processes
- Joints and Weld Types





75

### AWS STANDARD WELDING TERMS & DEFINITIONS (A3.0:2020)

**shielded metal arc welding (SMAW).**

An arc welding process with an arc between a covered electrode and the weld pool. The process is used with shielding from the decomposition of the electrode covering, without the application of pressure, and with filler metal from the electrode.



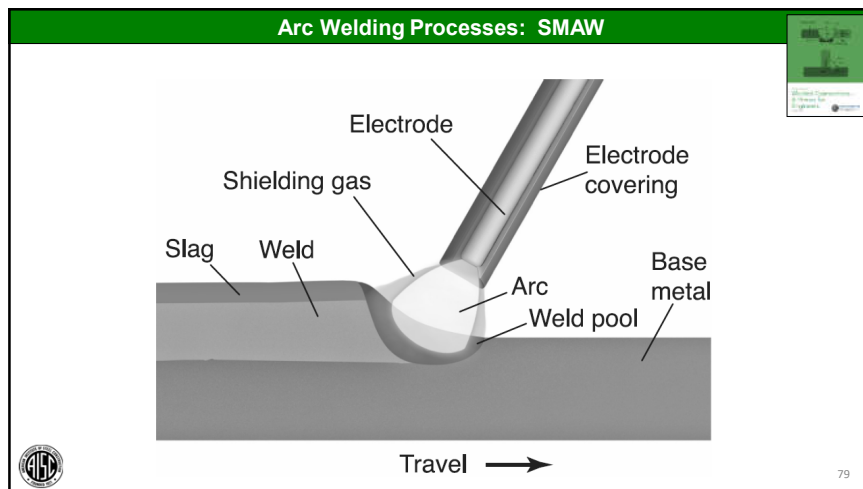
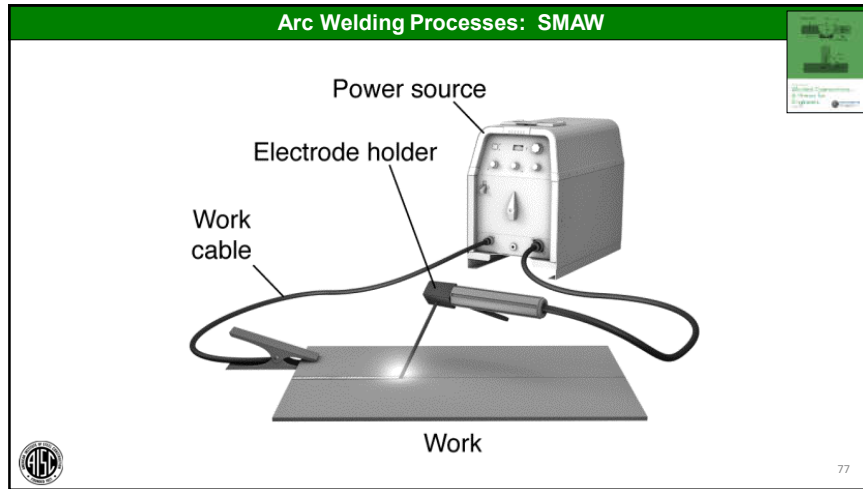

76



**Arc Welding Processes: SMAW**

**Advantages:**

- Simplicity
- Flexibility
- Familiarity





81

**Arc Welding Processes: SMAW**

**Limitations:**

- Variable resistor
- Electrodes are of finite length
- Stub loss
- Operator skill required



82

**ANSI Z49.1**

**Safety in Welding, Cutting, and Allied Processes**

Available by free download from AWS

**aws.org**

**www.aws.org/technical/facts**

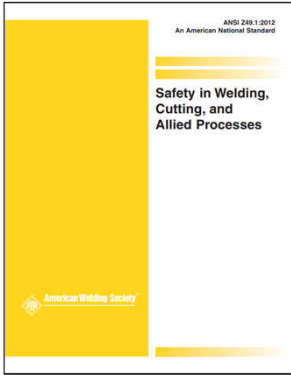

83

**The big four:**

- Arc
- Fire
- Electrical
- Fume

Not comprehensive.  
See Z49.1 for a complete listing

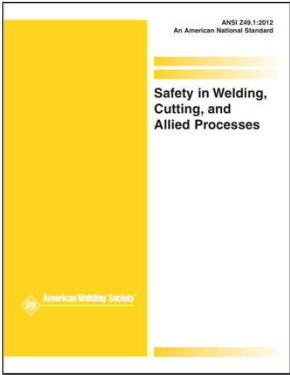

84

**AWS A5.1**

Specification for Carbon Steel Electrodes  
for Shielded Metal Arc Welding

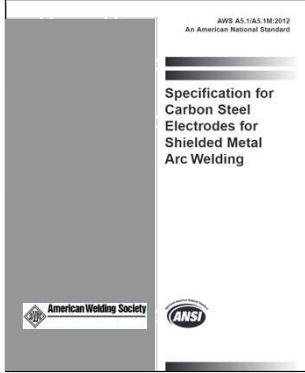

85

**AWS 5 Filler Metal Specifications**

**E7018**

Electrode \_\_\_\_\_

**70** ksi minimum specified tensile strength \_\_\_\_\_

**1** = Position of welding \_\_\_\_\_

**8** = Coating type, mechanical properties \_\_\_\_\_



86

**AWS 5 Filler Metal Specifications**

**E4918**

Electrode \_\_\_\_\_

**490** MPa min. specified tensile strength \_\_\_\_\_

**1** = Position of welding \_\_\_\_\_

**8** = Coating type, mechanical properties \_\_\_\_\_



87

**AWS STANDARD WELDING TERMS & DEFINITIONS (A3.0:2020)**

**flux cored arc welding (FCAW).**

An arc welding process using an arc between a continuous filler metal electrode and the weld pool. The process is used with shielding from a flux contained within the tubular electrode, with or without additional shielding gas, and without the application of pressure.



88

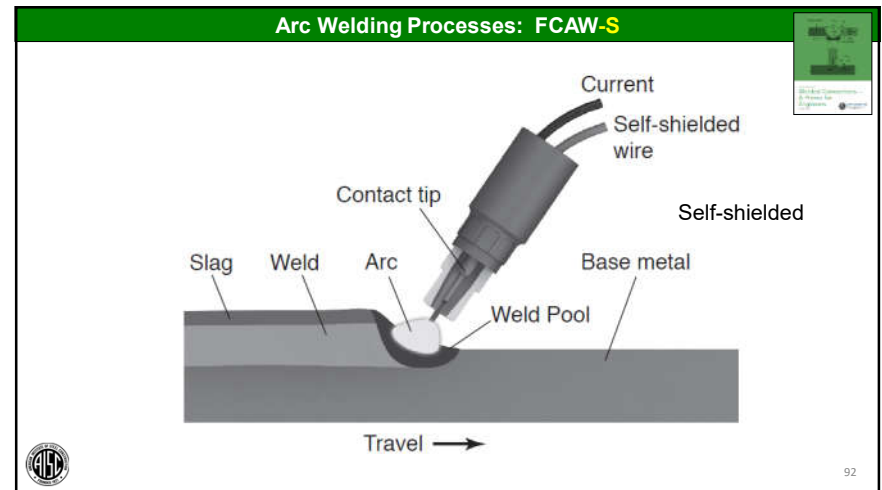
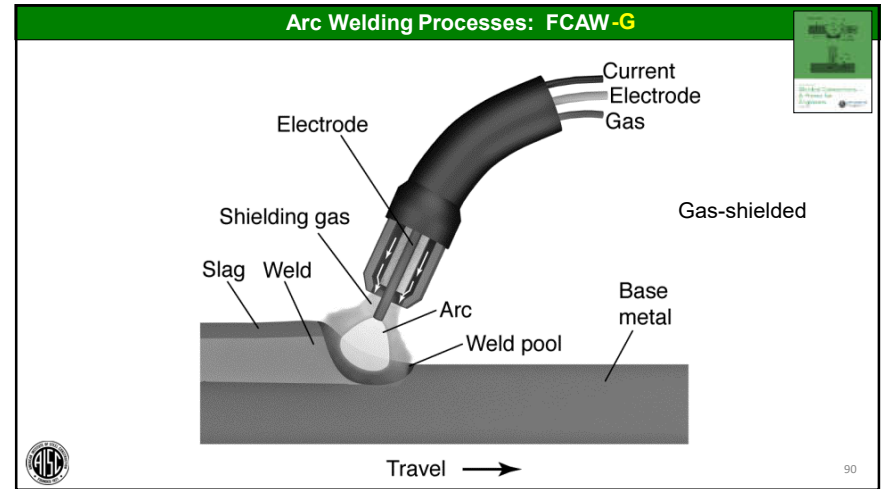
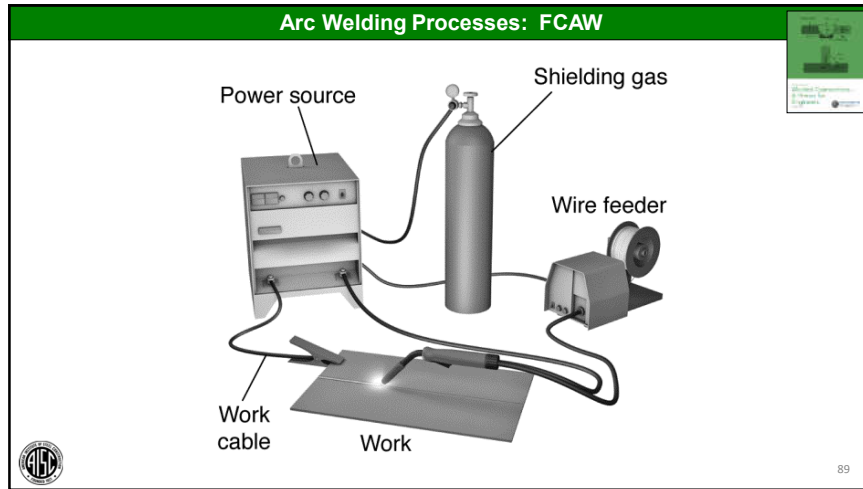





**Arc Welding Processes: FCAW**

**Advantages:**

- Electrode is continuous
  - Eliminates built-in starts and stops
    - Economic advantage
    - Starts and stops are potential sources of weld discontinuities
- Increased amperages (over SMAW)
  - Increased deposition rate and productivity
- Fixed resistance for a given electrode extension
  - More uniform welding conditions are maintained





94

**Arc Welding Processes: FCAW**

**Advantages:**

- Process is semiautomatic
  - Welders maintains the electrode extension (i.e., stickout distance) but do not need to maintain an arc length, nor do they feed the filler metal into the joint
- Process can also be mechanized or automatic





95

**Arc Welding Processes: FCAW**

**Limitations:**

- Welding equipment costs more and is less portable than for SMAW
- Changes are more complicated than for SMAW





96

**Arc Welding Processes: FCAW-G**

**Advantages:**

- More versatile than self-shielded flux-cored electrodes
- Provide better arc action
- High operator appeal
- Shielding from wind is not difficult in enclosed shop fabrication situations
- Weld appearance and quality are very good
- Higher-strength gas-shielded FCAW electrodes are available than for FCAW-S





97

**Arc Welding Processes: FCAW-G**

**Limitations:**

- The need to protect the gas shield
  - AWS D1.1 limits the maximum wind velocity to 5 mph [8 km/h]
- When welding under windy conditions, porosity is likely
- Studies have shown that at wind speeds less than 5 mph, and before onset of porosity, ductility and toughness may decrease
  - AWS D1.8 has limited maximum wind velocity to 3 mph [5 km/h]





98

**Arc Welding Processes: FCAW-S**

**Advantages:**

- Ideal when wind may disturb the gas shield (e.g., field conditions or relatively open fabrication shops)
  - Welds have been made up to 10 mph [16 km/h] without harmful effects
- No need for gas cylinders, hoses and regulators
- No concerns about gas nozzles being plugged with weld spatter
- Gun and cable assembly is simpler than for gas-shielded
  - More suitable for welding in restricted spaces





99

**Arc Welding Processes: FCAW-S**

**Limitations:**

- Technology is limited to 90 ksi [620 MPa] tensile strength or less
- Arc action not as good as FCAW-G





100

**AWS STANDARD WELDING TERMS & DEFINITIONS (A3.0:2020)**

**gas metal arc welding (GMAW).**

An arc welding process using an arc between a continuous filler metal electrode and the weld pool. The process is used with shielding from an externally supplied gas and without the application of pressure.

**Note: may use solid electrode, or metal cored electrode.**



101

**Arc Welding Processes: GMAW**

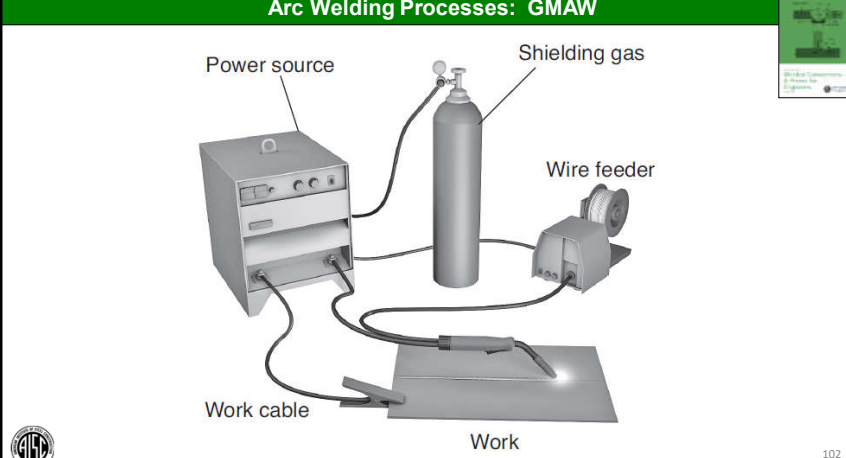



Power source

Shielding gas

Wire feeder

Work cable

Work



102

**Arc Welding Processes: GMAW**

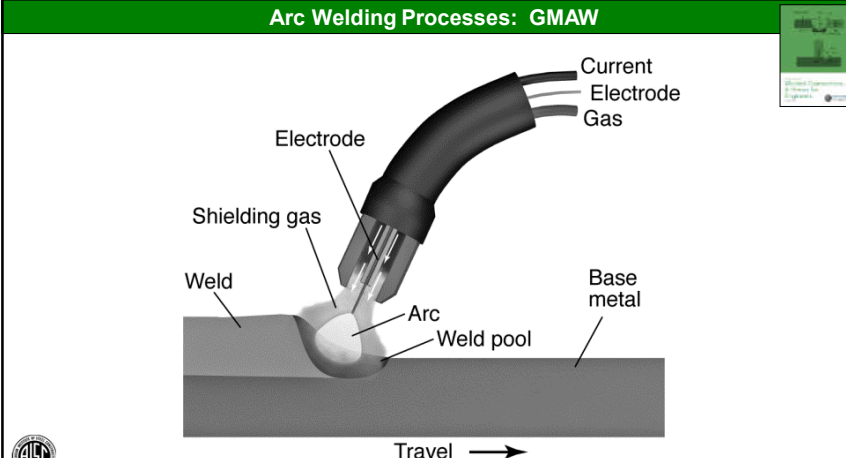

Current

Electrode

Gas

Electrode

Shielding gas



Weld

Arc

Weld pool

Base metal

Travel →



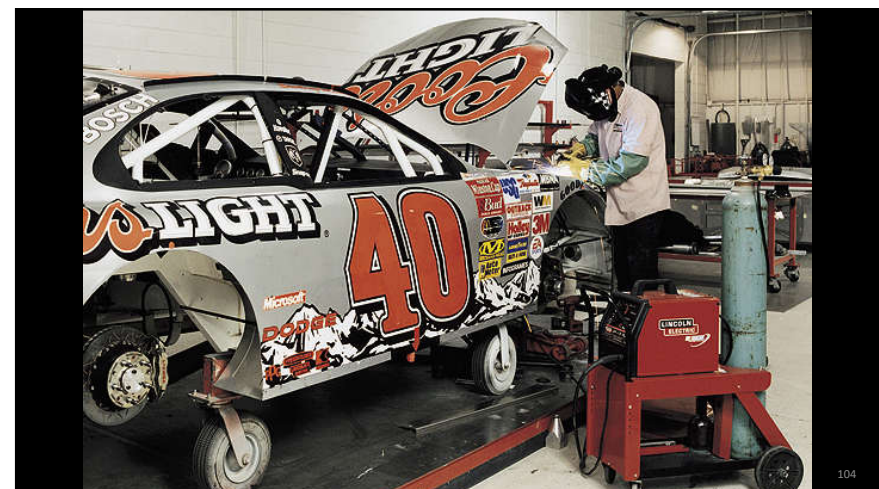

103



### Arc Welding Processes: GMAW

**GMAW Modes of Metal Transfer**

- Spray
- Globular
- Short-Circuiting (shortarc)
- Pulsed



105

### Arc Welding Processes: GMAW Spray

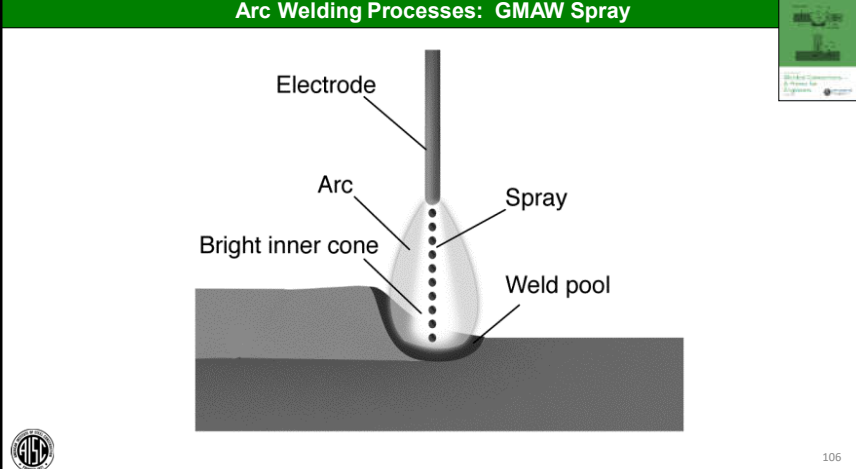

The diagram illustrates the spray metal transfer process. An electrode is shown above a workpiece. An arc is established between the electrode tip and the workpiece. A spray of molten metal droplets is shown moving from the electrode tip through the arc into the weld pool. Labels include: Electrode, Arc, Spray, Bright inner cone, and Weld pool.





106

### Arc Welding Processes: GMAW

**Mode of Transfer-dependent Advantages and Limitations:**

- Spray
  - Permits higher deposition rates and deposits welds with good appearance
  - Requires higher-cost, argon-based shielding gas mixtures, and can only be used in horizontal and flat positions



107

### Arc Welding Processes: GMAW Globular

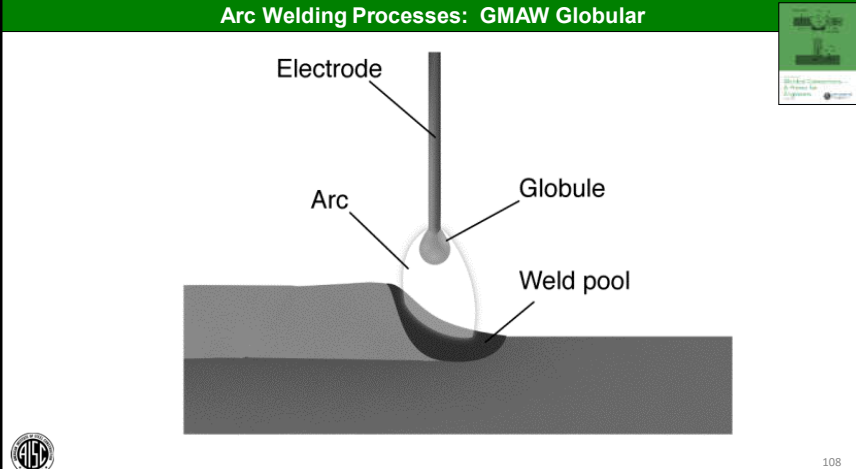

The diagram illustrates the globular metal transfer process. An electrode is shown above a workpiece. An arc is established between the electrode tip and the workpiece. A single, large globule of molten metal is shown moving from the electrode tip through the arc into the weld pool. Labels include: Electrode, Arc, Globule, and Weld pool.





108

### Arc Welding Processes: GMAW

**Mode of Transfer-dependent Advantages and Limitations:**

- Globular
  - Uses low-cost carbon dioxide shielding and offers high deposition rates
  - Weld appearance is inferior to spray transfer; excessive weld spatter is typical; restricted to horizontal and flat positions



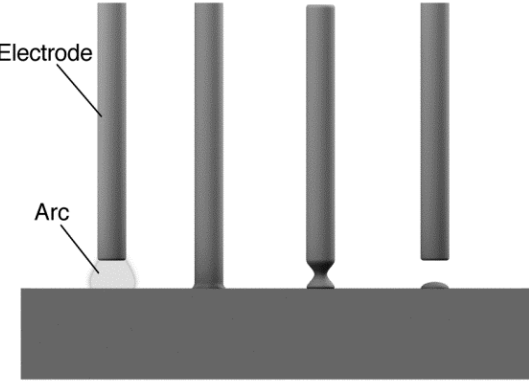

109

### Arc Welding Processes: GMAW Short-Circuiting



Electrode

Arc





110

### Arc Welding Processes: GMAW

**Mode of Transfer-dependent Advantages and Limitations:**

- Short-circuit
  - Ideal for sheet metal; can be used for vertical and overhead positions
  - Strong tendency for fusion-type defects (incomplete fusion) makes it undesirable for most structural applications
  - Not prequalified in AWS D1.1
  - Welders must be qualified with the short-circuit mode of transfer



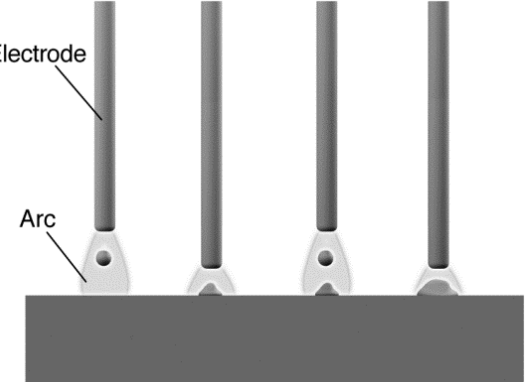

111

### Arc Welding Processes: GMAW Pulsed



Electrode

Arc





112

**Arc Welding Processes: GMAW**

**Mode of Transfer-dependent Advantages and Limitations:**

- Pulsed
  - Permits all-position welding; deposits weld with good appearance
  - Requires use of more expensive, argon-based shielding gas mixtures
  - Welding equipment is more expensive and complex





113

**Arc Welding Processes: GMAW**

**Advantages:**

- No slag covers the weld; cleanup is simple and low cost
- Electrodes cost less than flux-cored electrodes
- Deposits welds with low levels of diffusible hydrogen
  - Significant advantage for welding on high strength steels
- Carries advantages of automatic and semiautomatic processes
  - Many robotic welding applications use GMAW, due to freedom from slag cleanup
  - Multiple-pass welding is easily accomplished





114

**Arc Welding Processes: GMAW**

**Limitations:**

- Process is more sensitive to contaminants on the steel surface (such as mill scale, rust, and oil)
  - May result in porosity
  - Heavy scale may inhibit fusion
- Limited similar to FCAW-G
  - If gas shield is disturbed, porosity will result
  - Even before onset of porosity, ductility and toughness may deteriorate





115

**AWS STANDARD WELDING TERMS & DEFINITIONS (A3.0:2010)**

**submerged arc welding (SAW).**

An arc welding process using an arc or arcs between a bare metal electrode and the weld pool. The arc and molten metal are shielded by a blanket of granular flux on the workpieces. The process is used without pressure and with filler metal from the electrodes and sometimes from a supplemental source (welding rod, flux, or metal granules).



116

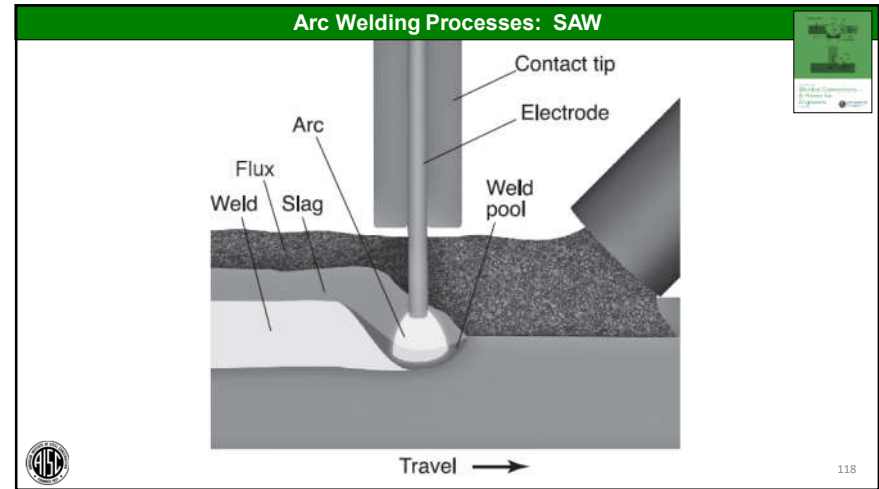
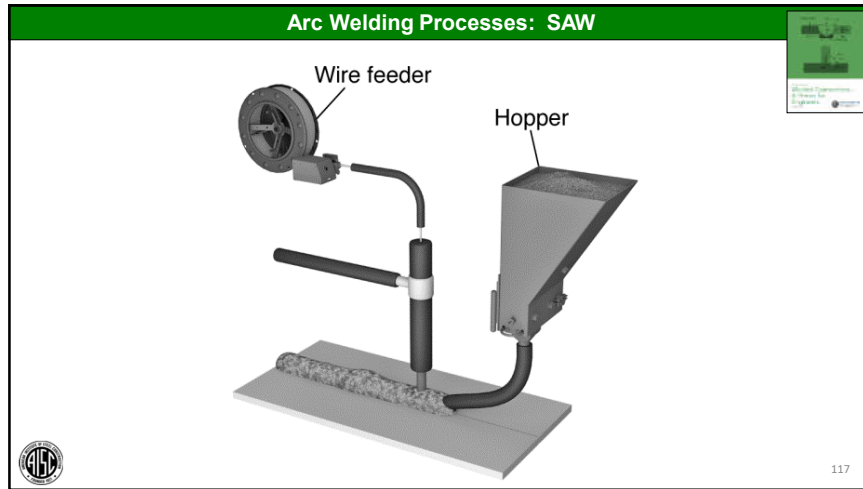



121





122

**Arc Welding Processes: SAW**

**Advantages:**

- Uses higher welding currents, leading to higher productivity and deeper penetration
  - Deeper penetration may allow fillet weld sizes to be reduced or may permit the use of groove weld details that require less weld metal
- Square wave technology may further increase deposition rate without increasing current
- For higher deposition rates, a second or third electrode can be added into the system to further increase productivity
- Process is typically mechanized or automatic
  - Welds are usually continuous for length of the joint





123

**Arc Welding Processes: SAW**

**Advantages:**

- Welds made under protective layer of flux are excellent in appearance and spatter-free
  - Particularly significant for architecturally exposed structural steel (AESS)
- Freedom from the open arc
  - Welder does not need to use the standard protective helmet
  - Operations can be done in tight, restricted areas
  - Produces little smoke, therefore can be used in situations with restricted ventilation





124

### Arc Welding Processes: SAW

**Limitations:**

- Freedom from open arc does not allow the operator to observe the weld puddle
  - When done semiautomatically, operator must learn to propel gun carefully to ensure uniform bead contour
  - Degree of skill is significant for multiple-pass welds
- Better for long, uninterrupted seams rather than short, intermittent welds
- Restricted to flat and horizontal position





125

### AWS STANDARD WELDING TERMS & DEFINITIONS (A3.0:2020)

**gas tungsten arc welding (GTAW).**

An arc welding process using an arc between a tungsten electrode (nonconsumable) and the weld pool. The process is used with shielding gas and without the application of pressure.



126

### Arc Welding Processes: GTAW

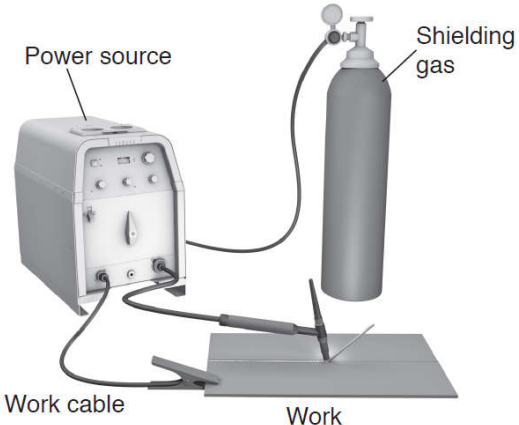



Power source

Shielding gas

Work cable

Work



127

### Arc Welding Processes: GTAW

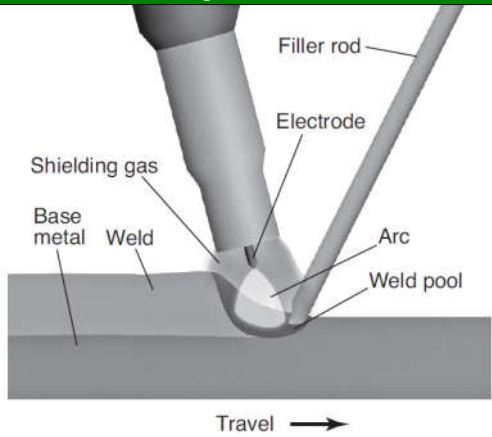

Filler rod

Electrode

Shielding gas



Base metal

Weld

Arc

Weld pool

Travel →



128



129



130

**AWS STANDARD WELDING TERMS & DEFINITIONS (A3.0:2010)**

**electroslag welding (ESW).**

A welding process producing coalescence of metals with molten slag, melting the filler metal and the surfaces of the workpieces. The weld pool is shielded by this slag, which moves along the full cross section of the joint as welding progresses. The process is initiated by an arc that heats the slag. The arc is then extinguished by the conductive slag, which is kept molten by its resistance to electric current passing between the electrode and the workpieces.



131

**AWS STANDARD WELDING TERMS & DEFINITIONS (A3.0:2010)**

**electrode gas welding (EGW).**

An arc welding process using an arc between a continuous filler metal electrode and the weld pool, employing approximately vertical welding progression with backing to confine the molten weld metal. The process is used with or without an externally supplied shielding gas and without the application of pressure.



132

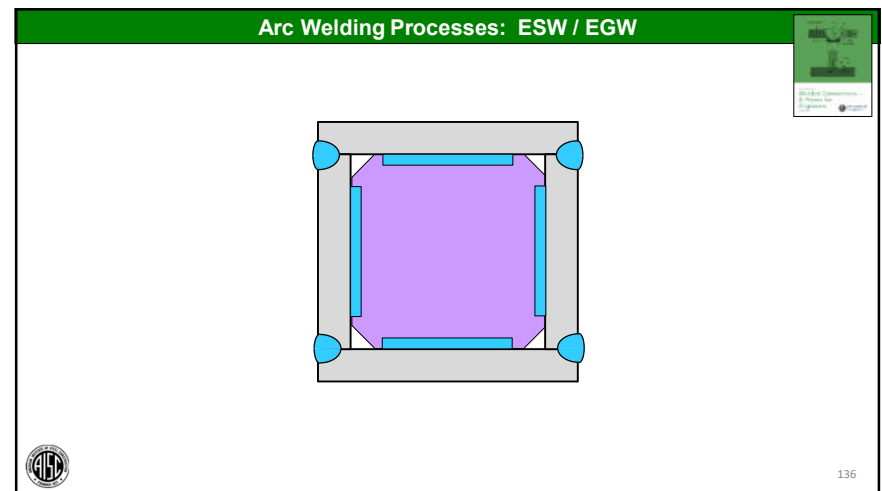
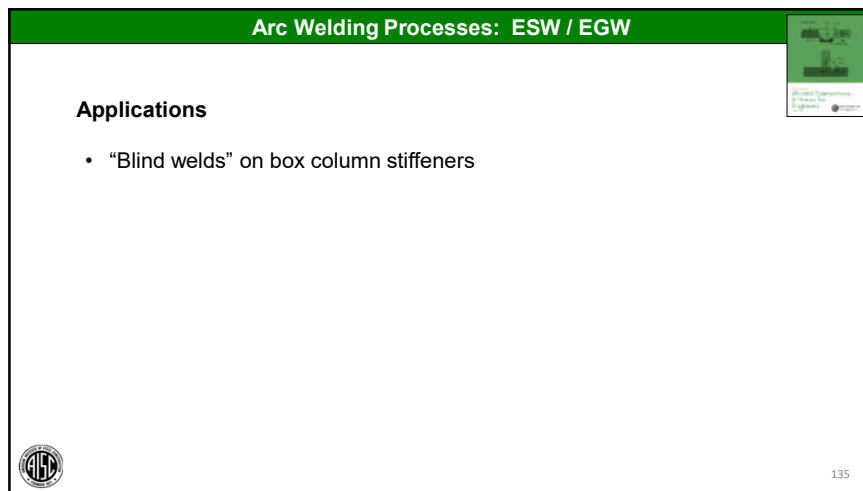
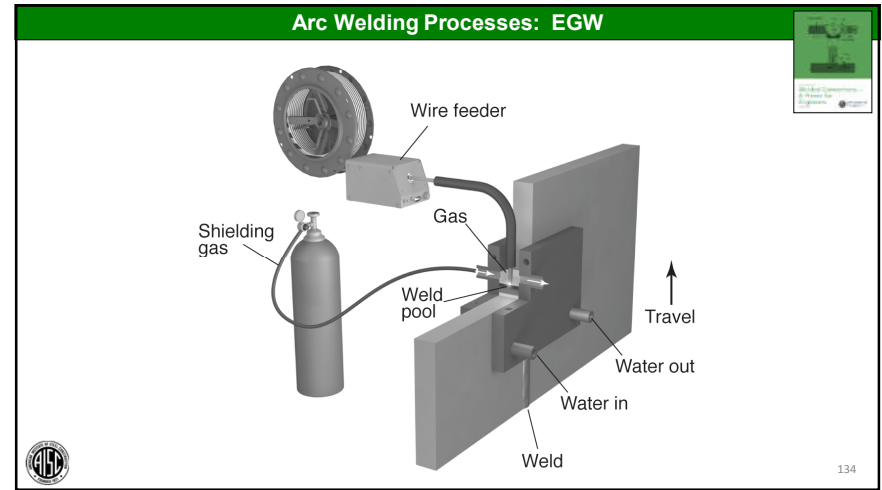
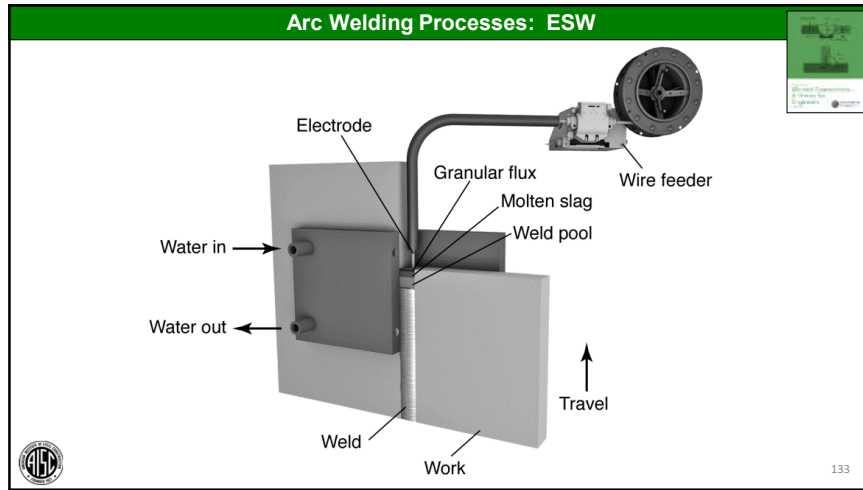

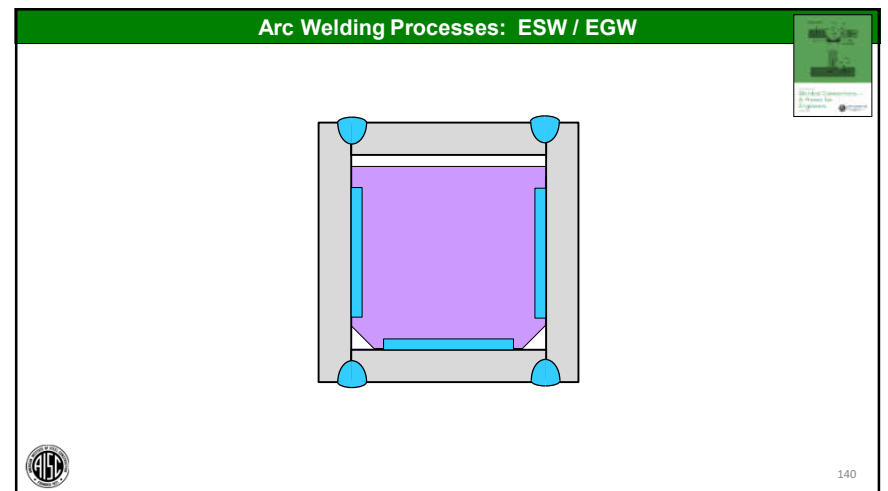
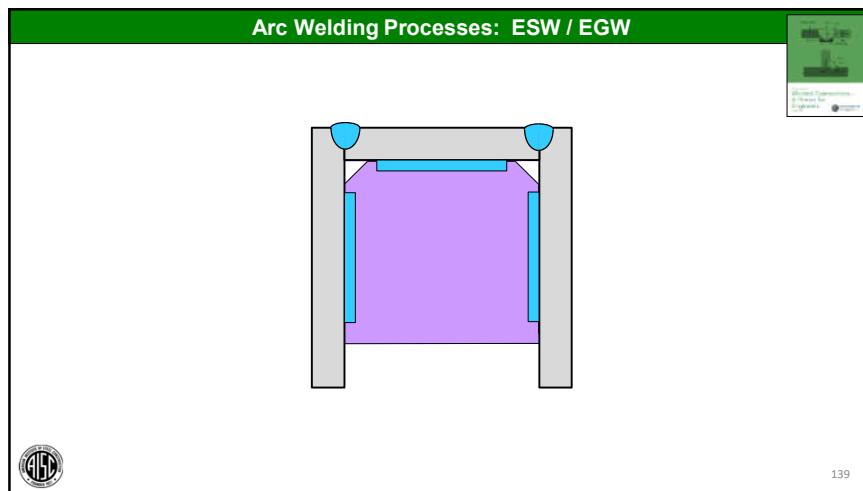
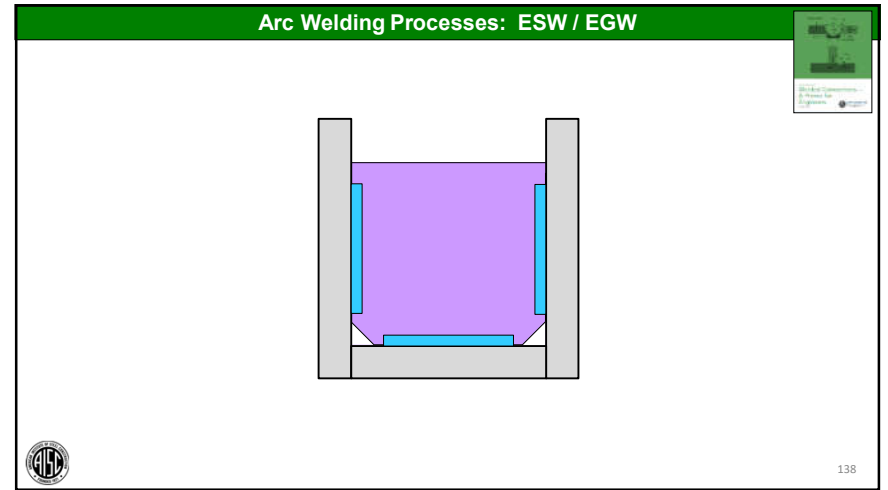
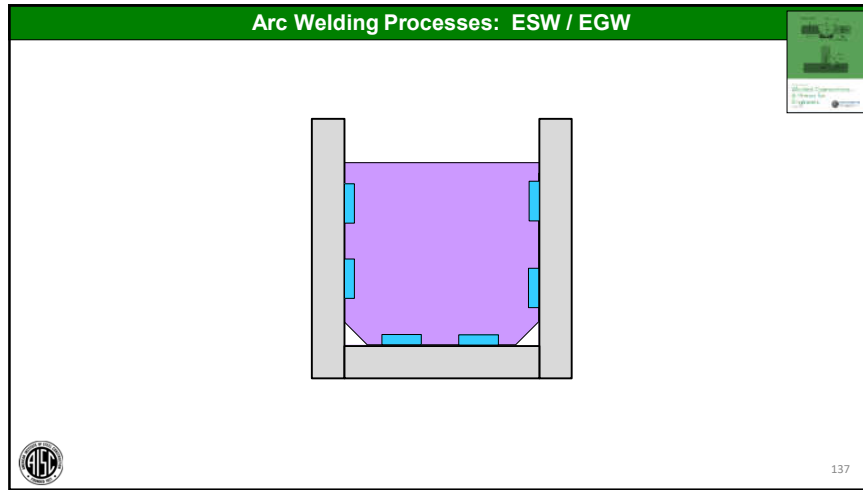

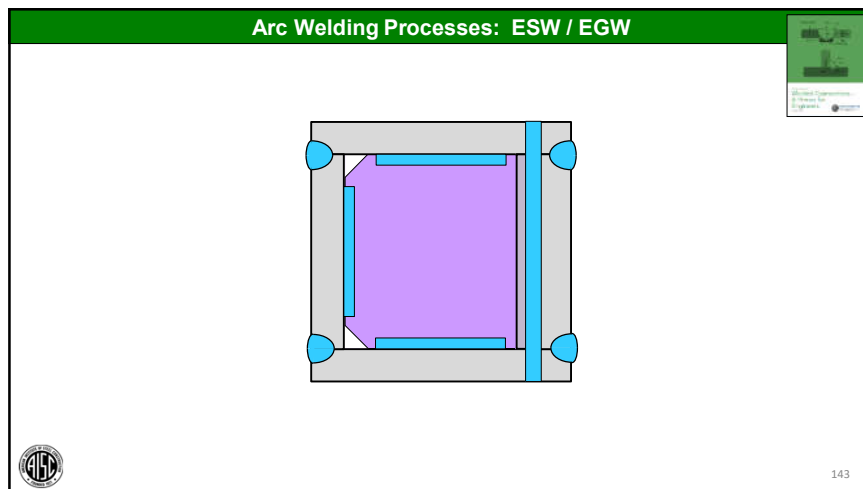
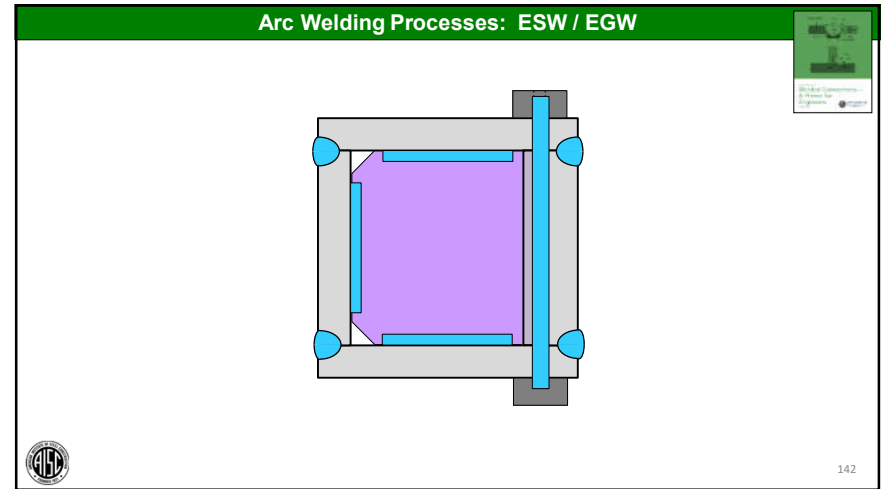
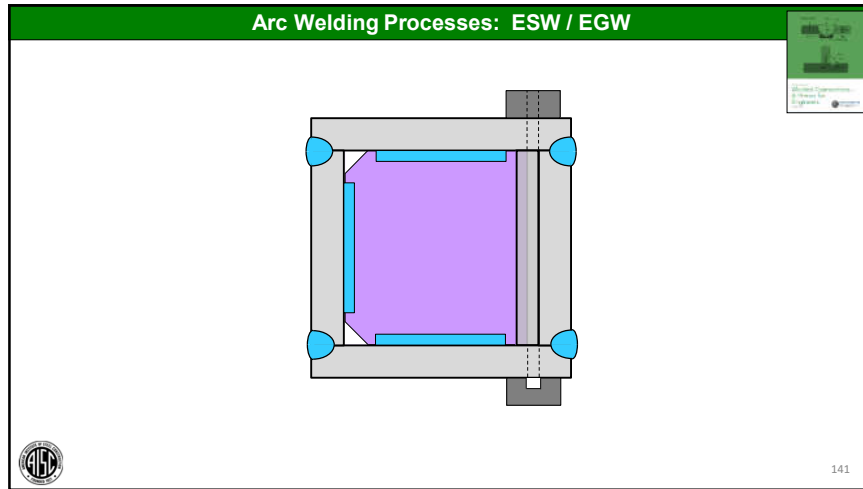

Arc Welding Processes: ESW / EGW

**Applications**

- "Blind welds" on box column stiffeners
- Flange splices for plate girders
- Miscellaneous applications (columns to base plates, flange plates to columns, continuity plates)



144

The slide contains a list of applications for ESW/EGW welding. The list includes: "Blind welds" on box column stiffeners, Flange splices for plate girders, and Miscellaneous applications (columns to base plates, flange plates to columns, continuity plates). The slide is labeled '144' in the bottom right corner.

**Arc Welding Processes: ESW / EGW**

**Advantages:**

- Very high deposition rates
- Normally, joint details involve square edges, eliminating beveling costs
- Material handling might be reduced because plates do not need to be flipped as is the case for double-sided welds made with SAW, for example
- Angular distortion can be reduced
- Advantageous for cyclically loaded structures
  - Center of the vertical weld is last to solidify, putting the face of the weld in compression, enabling better resistance to cyclic tensile stresses





145

**Arc Welding Processes: ESW / EGW**

**Advantages:**

- Ability to weld in blind joints (e.g., diaphragm plates in box columns)
  - Can weld through a hole in the box
- Ideal for welding on thicker materials (1 in. [25 mm] or greater)





146

**Arc Welding Processes: ESW / EGW**

**Limitations:**

- Not well-suited for thinner materials
- Equipment and fixturing are more expensive and less flexible
- Sensitive process with many variables
  - Specific operator training is required
  - AWS D1.1 requires all ESW and EGW welding procedure specifications be qualified by test
  - Different variables: fit of copper shoes to the work, temperature of the shoes, thickness of the slag layer
- Large heat affected zone and potentially low fracture toughness of welds





147

**AWS STANDARD WELDING TERMS & DEFINITIONS (A3.0:2010)**

**arc stud welding (SW).**

An arc welding process using an arc between a metal stud, or similar part, and the other workpiece. The process is used without filler metal, with or without shielding gas or flux, with or without partial shielding from a ceramic or graphite ferrule surrounding the stud, and with the application of pressure after the faying surfaces are sufficiently heated.



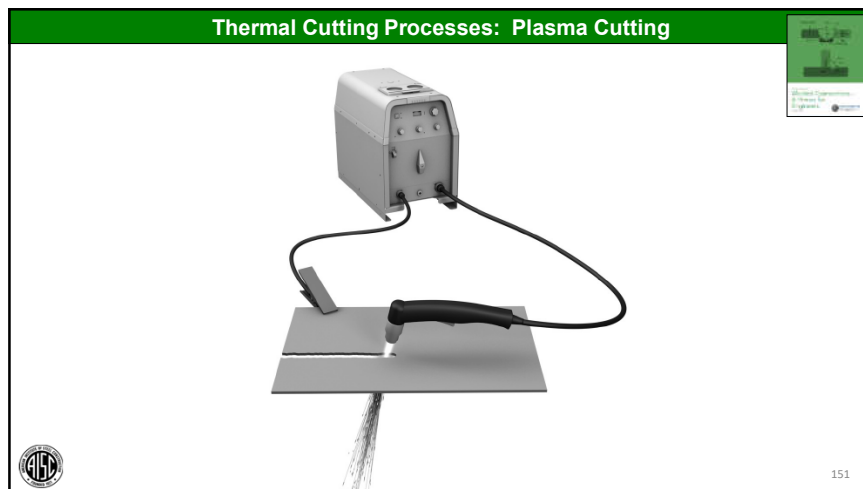
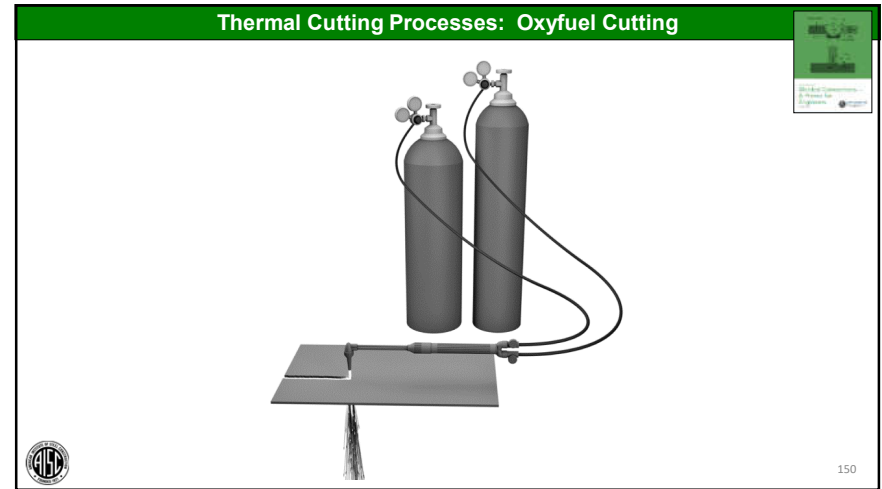
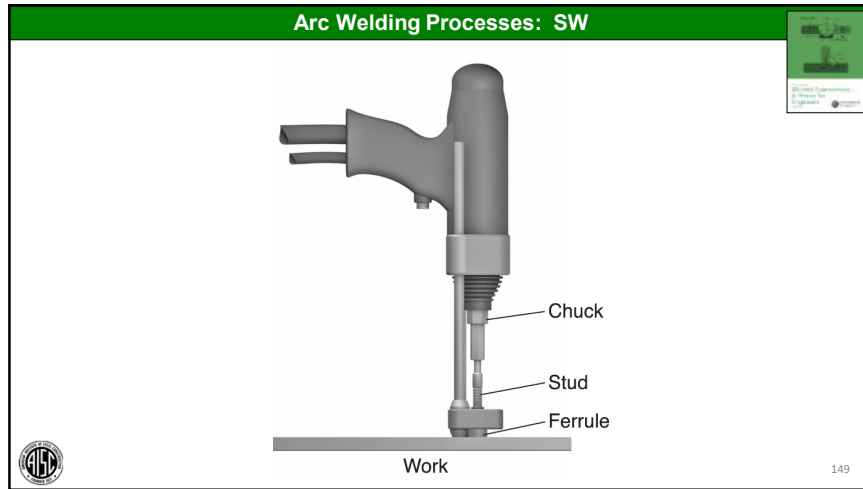

148



### Cutting Process: Water jet cutting

- Used pressurized stream of water to cut material
- Automated and accurate
- No oxidized surface and no heat affected zone (HAZ)
- More costly and not normally used in steel fabrication
- Permitted by AISC 360 (for cutting holes)





153

### Arc Welding Processes

**The selection of which process to use is typically best left up to those doing the welding.**

- Properly applied, all processes are capable of delivering quality welds
- Improperly applied, all processes may not deliver quality welds
- Mode of welding (manual, semiautomatic, automatic, robotic) will impact process selection
- Typically viewed as part of the Contractor's means and methods





154

### Arc Welding Processes

**Typical welding process applications:**

- **GMAW:** for shop welding on clean parts; often the choice for robotic applications
- **FCAW-G:** for shop welding on steel with mill scale, rust
- **FCAW-S:** for field welding
- **SAW:** for big, long welds that lend themselves to automation
- **GTAW:** for special alloys, high quality welds, critical repairs
- **SMAW:** maintenance welding, field welding, tack welding, repair welding, miscellaneous fabrication





155

### WELDED CONNECTION BASICS

**Outline**

- Applicable Codes
- Arc Welding Processes – Overview
- Welding and Thermal Cutting Processes
- ➔ Joints and Weld Types



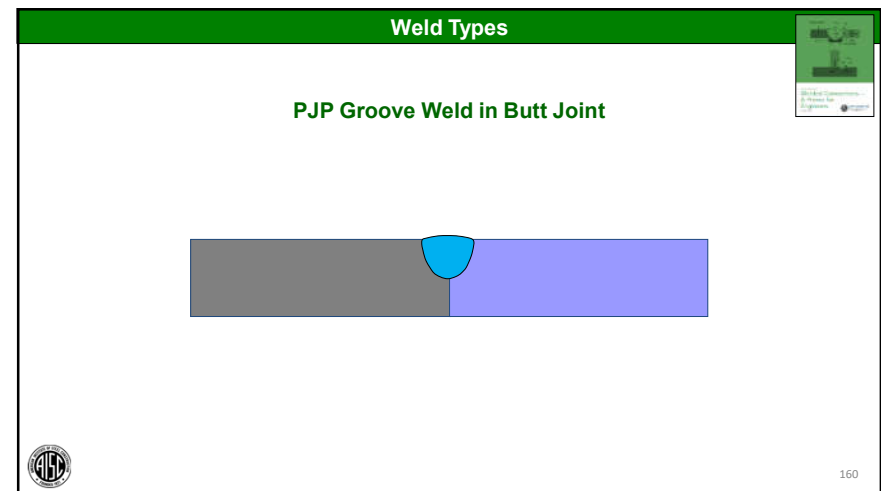
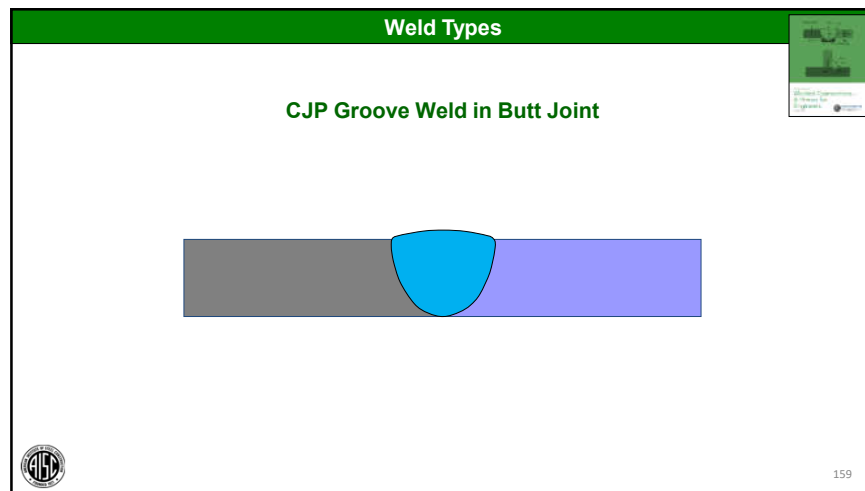
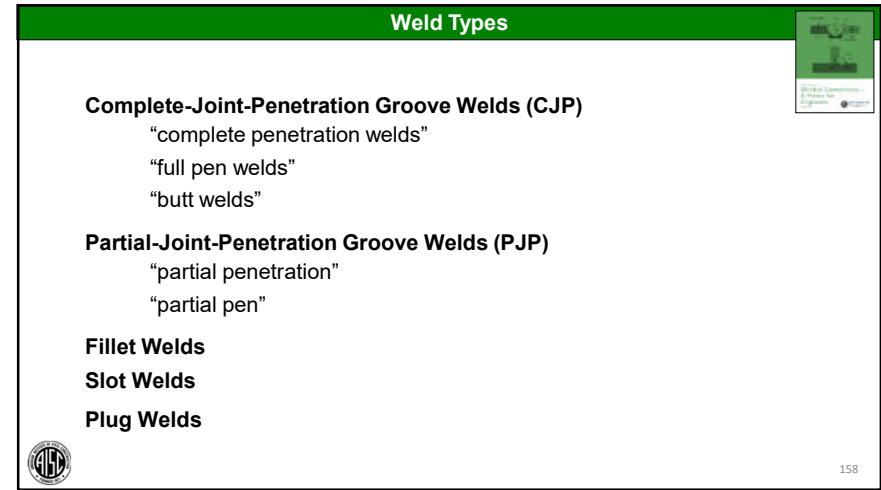
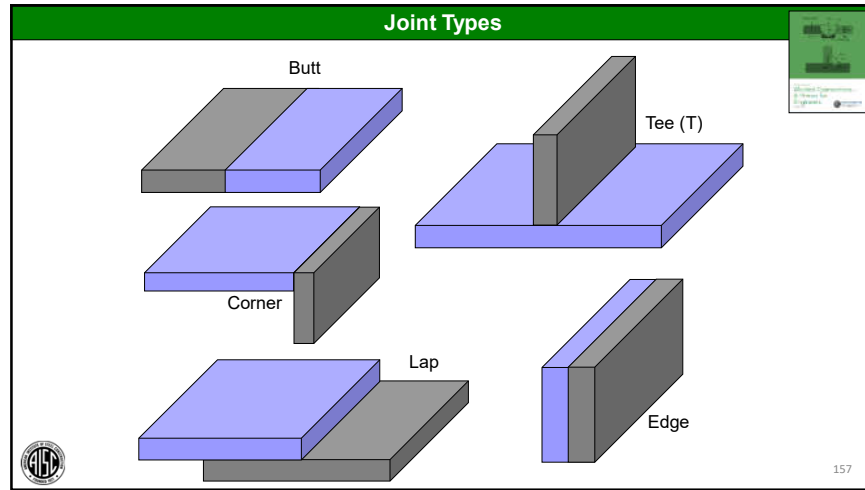

156

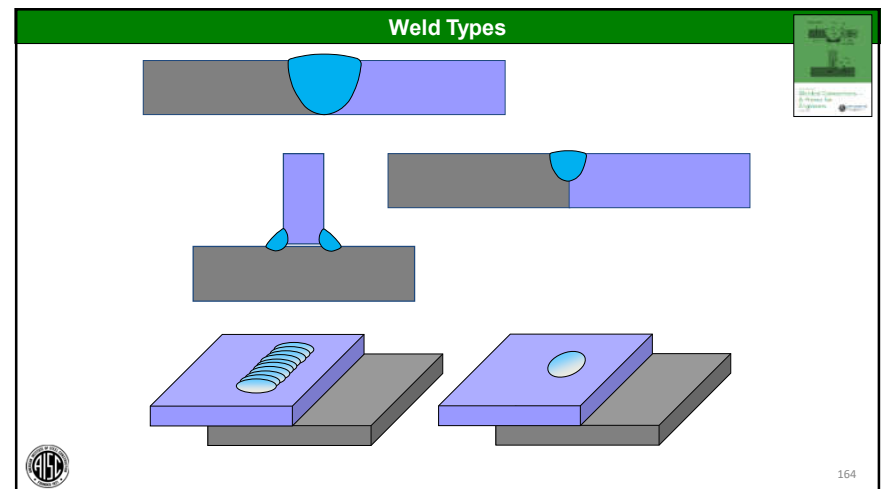
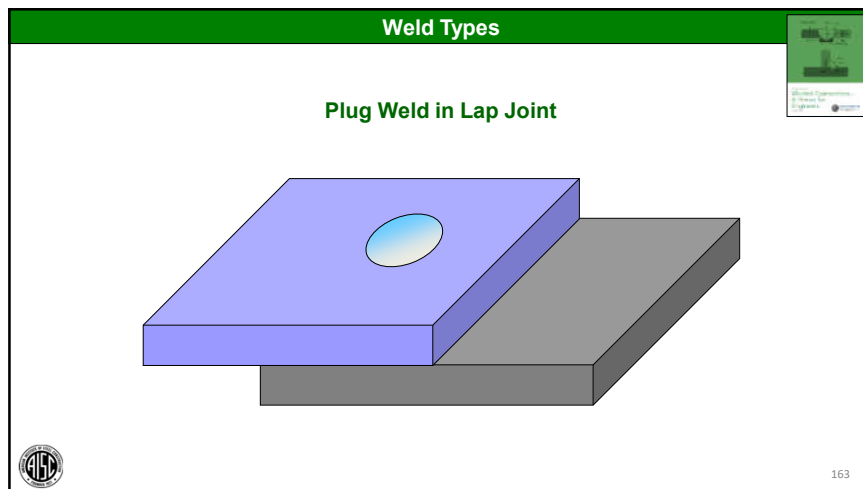
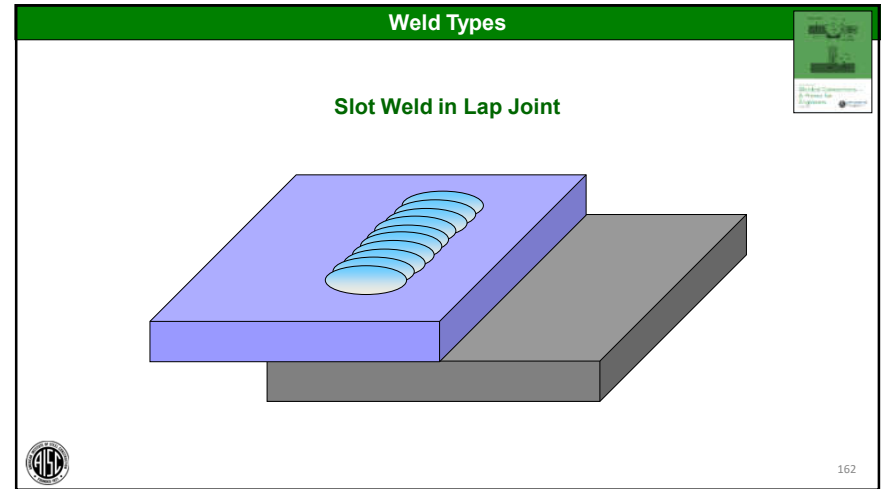
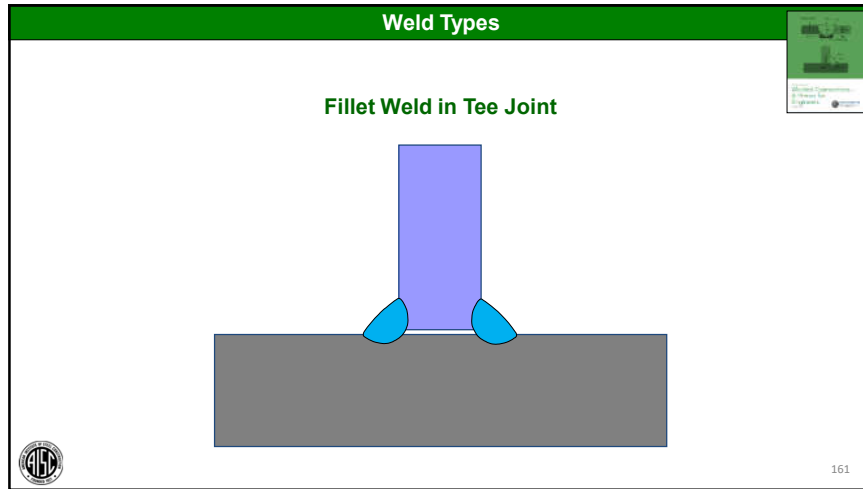



### Groove Welds

- Applied to butt, tee, corner joints
- CJP = full strength (for statically loaded connections)
- PJP = partial strength
- Tension vs. compression vs. shear



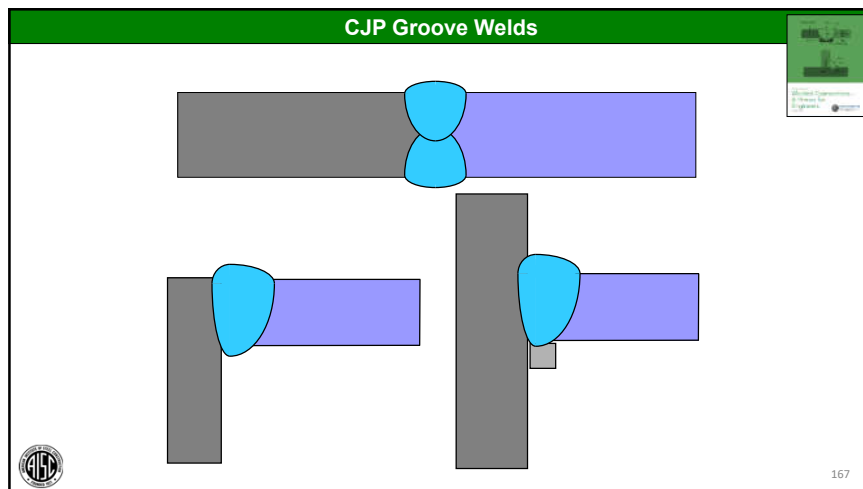
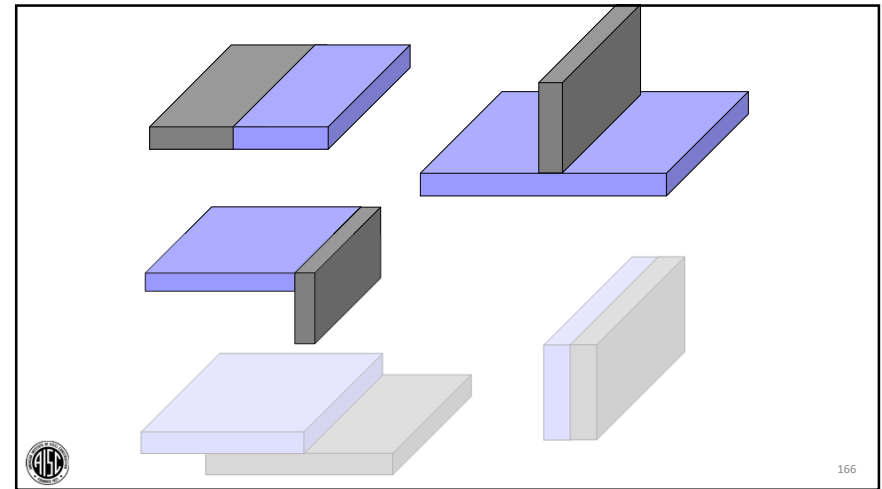

165



### CJP Groove Welds

- Throat = plate thickness



168

### CJP Groove Welds

**Weld Throat Dimension ( $t_w$ )**

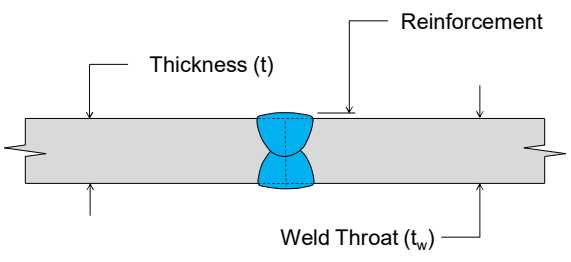

The diagram shows two steel plates joined by a groove weld. The thickness of the plates is labeled as  $t$ . The weld throat, which is the narrowest part of the joint, is labeled as  $t_w$ . The weld metal is shown in blue, and the reinforcement is indicated by arrows pointing to the weld metal.

Thickness ( $t$ )

Reinforcement

Weld Throat ( $t_w$ )

169

### CJP Groove Welds

- Throat = plate thickness
- No design calculations are required for statically loaded connections, when “matching” filler metal is used

170

### CJP Groove Welds

**Complete-Joint-Penetration Groove Weld (CJP)**

Single sided

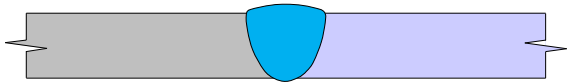

The diagram shows a single-sided groove weld between two steel plates. The weld metal is shown in blue, and the groove is filled with weld metal.

171

### CJP Groove Welds

**Complete-Joint-Penetration Groove Weld (CJP)**

Double sided

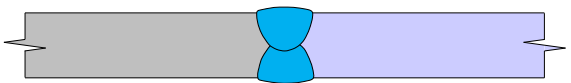

The diagram shows a double-sided groove weld between two steel plates. The weld metal is shown in blue, and the groove is filled with weld metal from both sides.

172

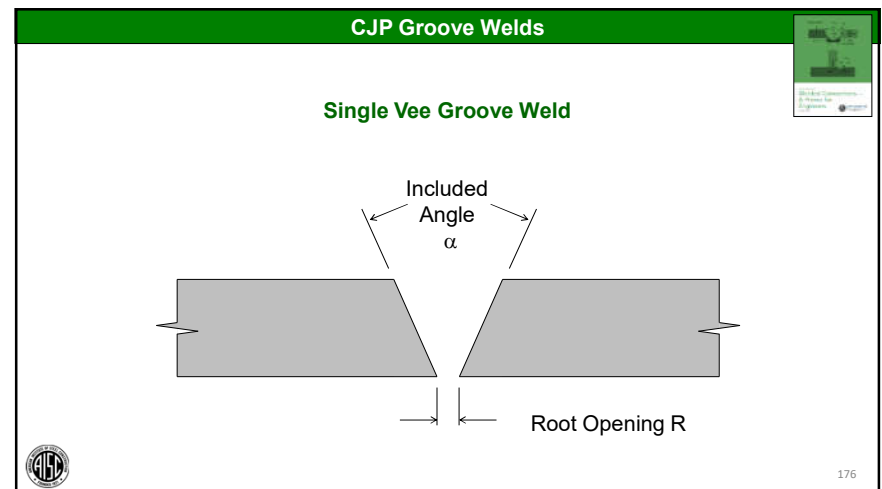
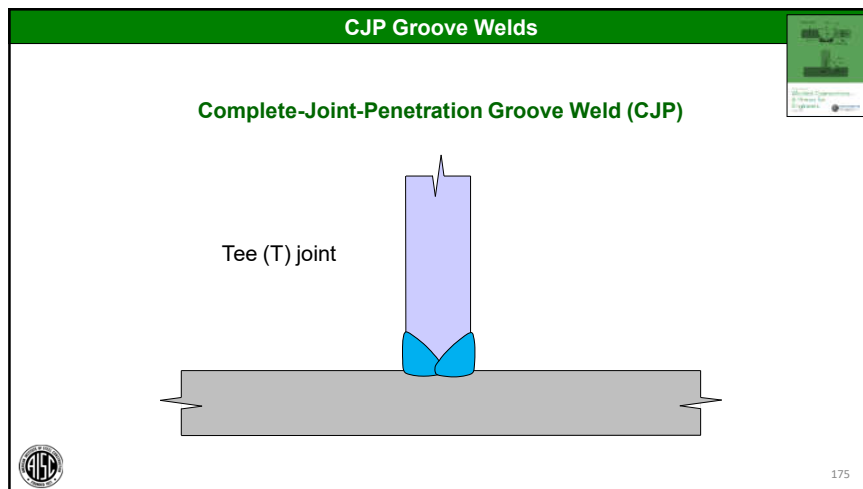
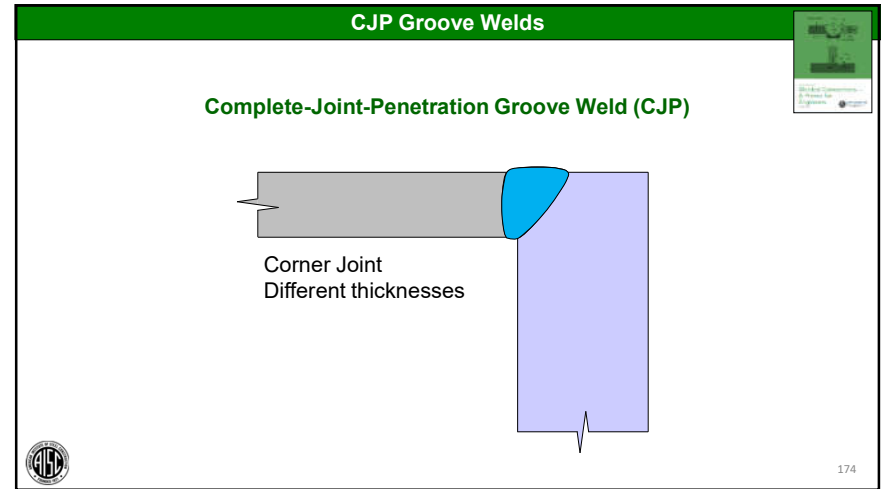
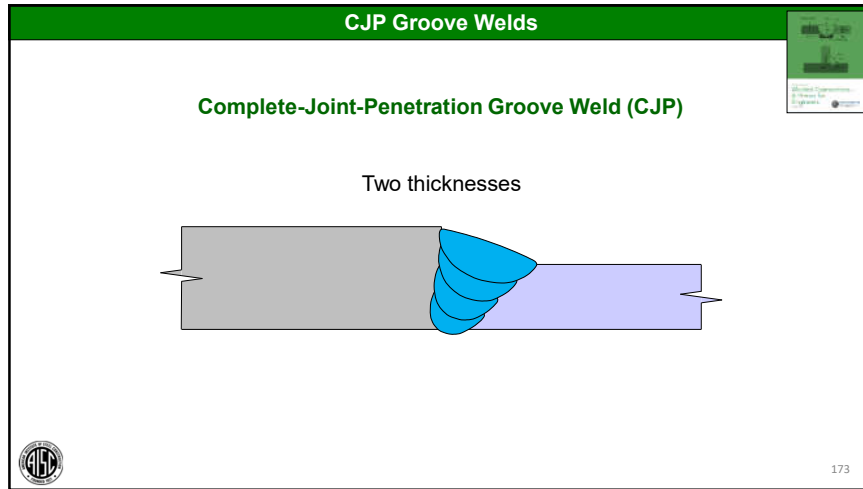

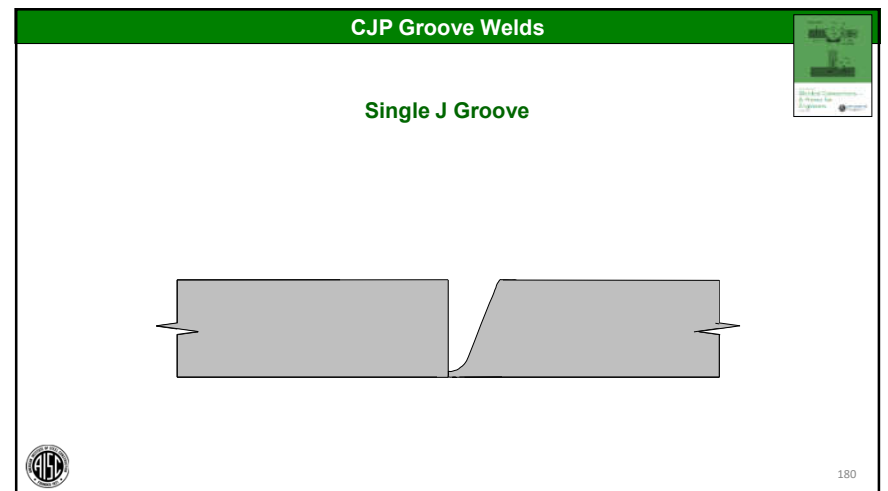
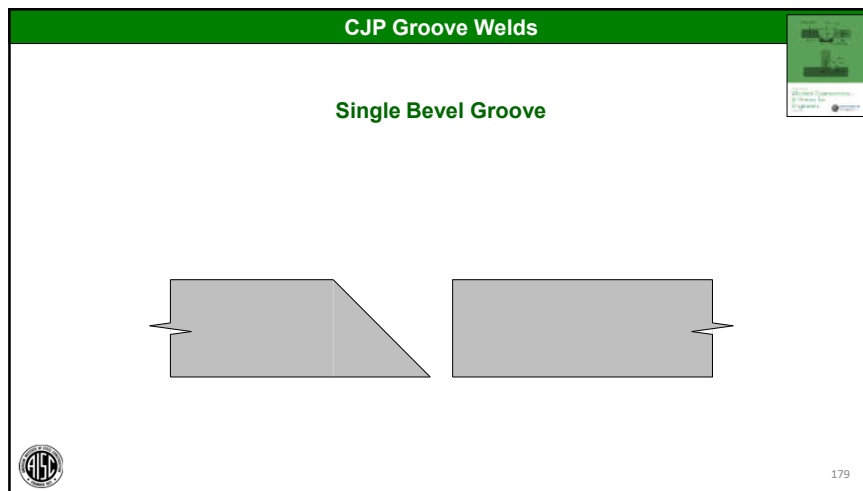
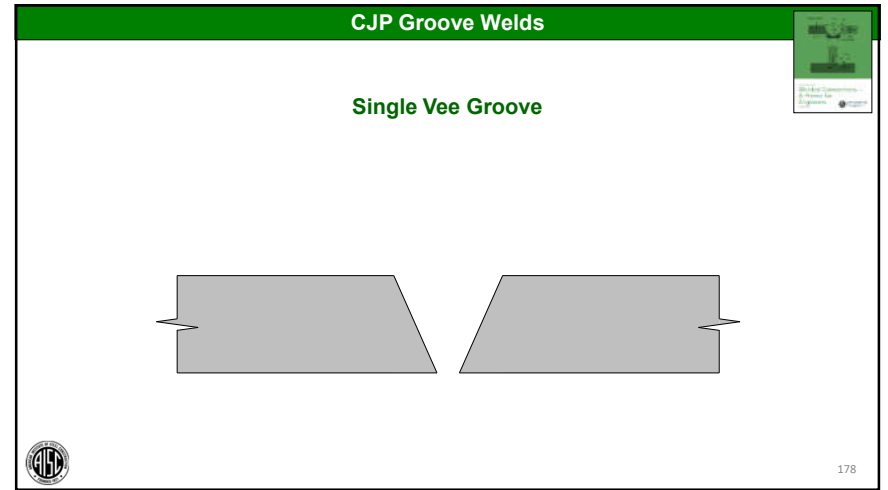
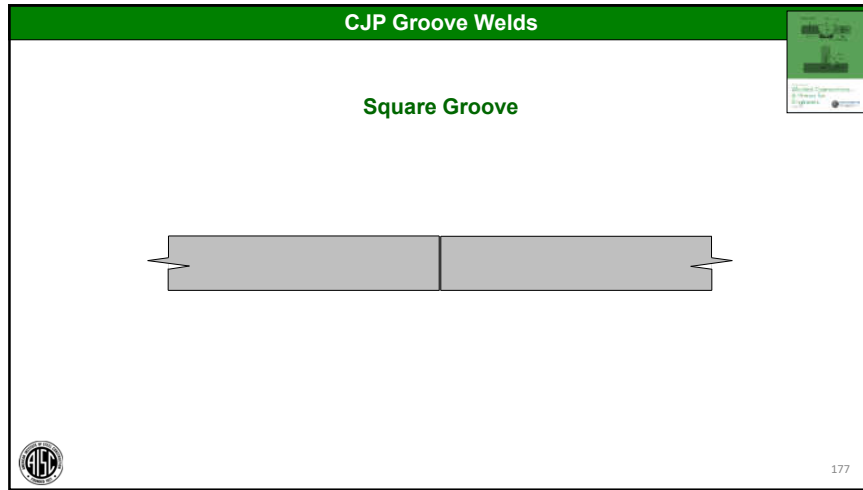

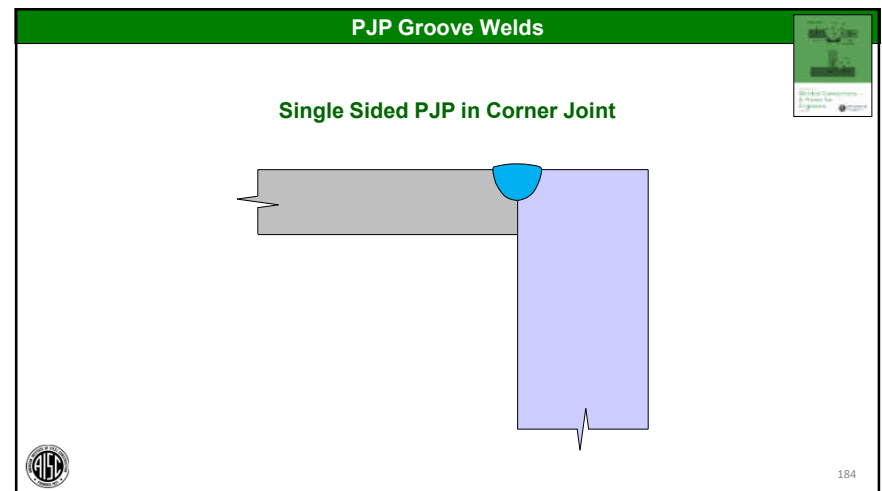
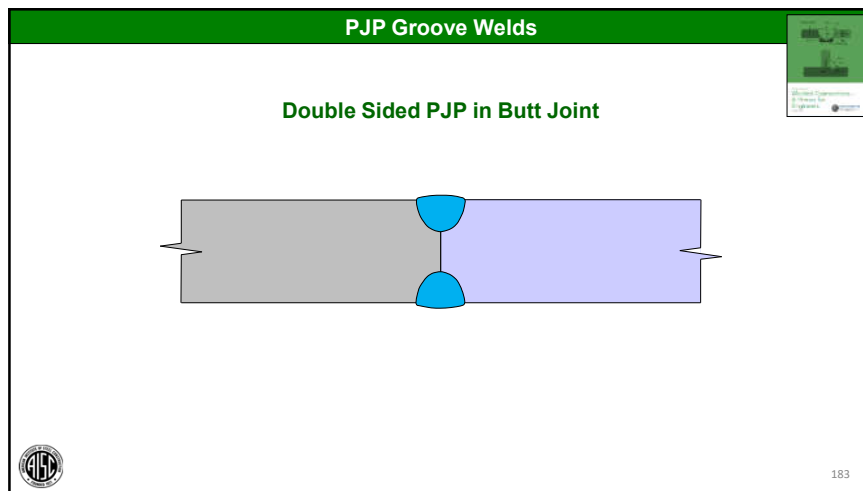
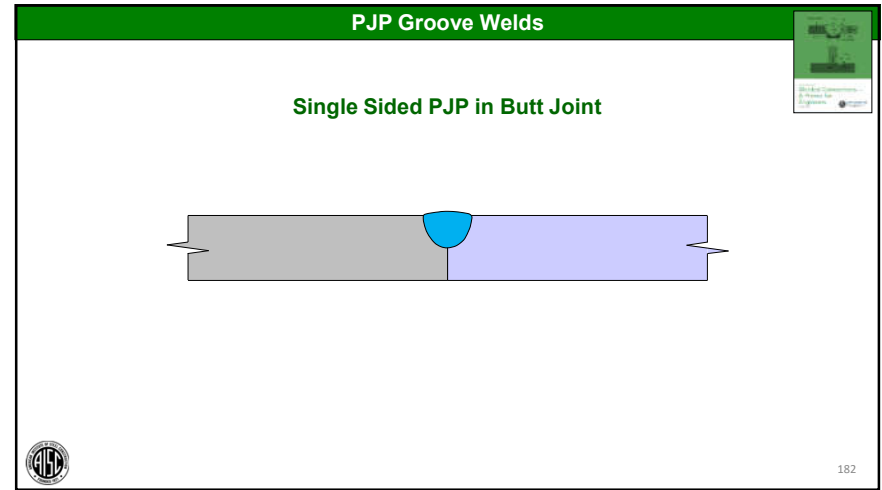
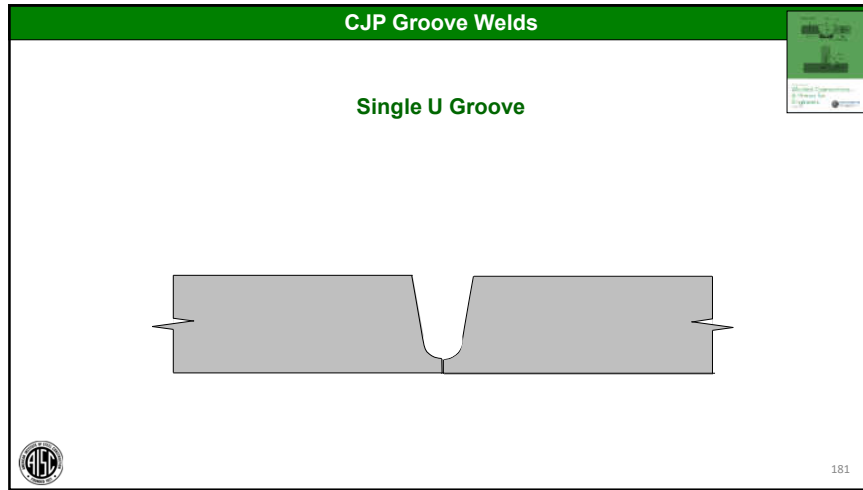

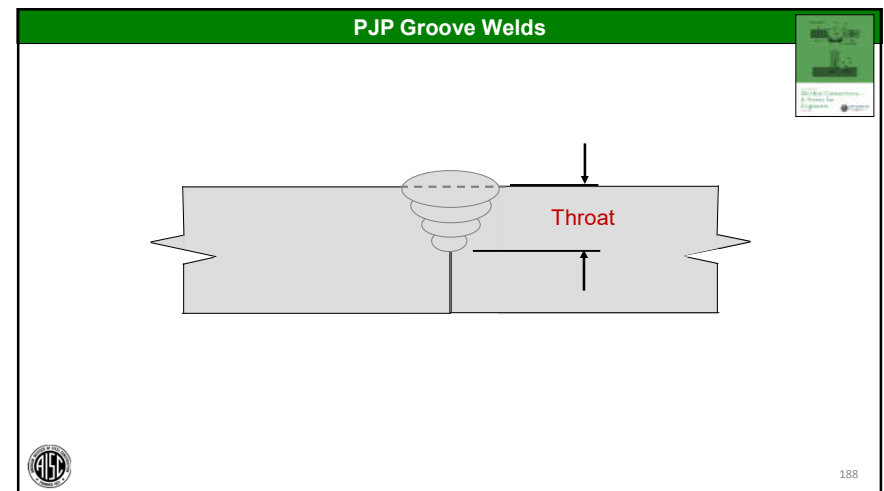
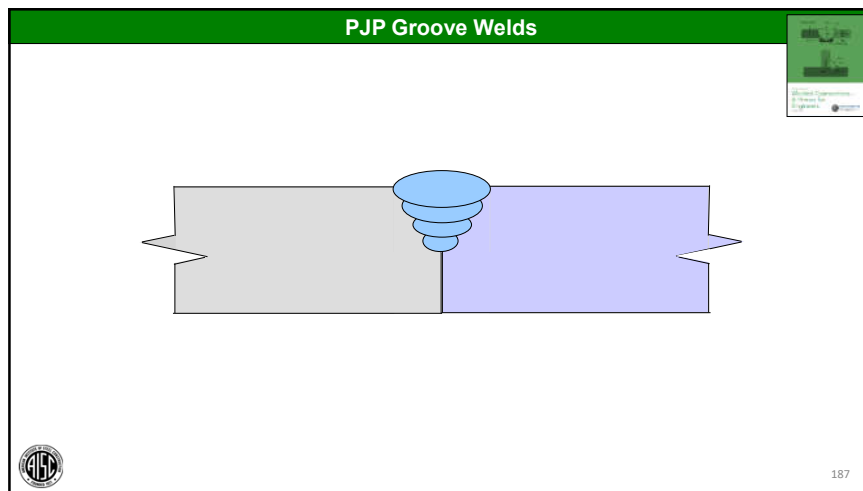
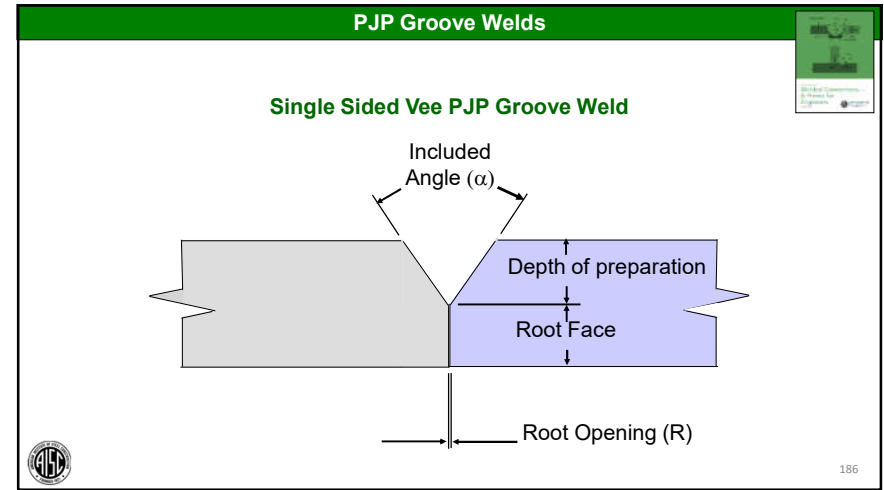
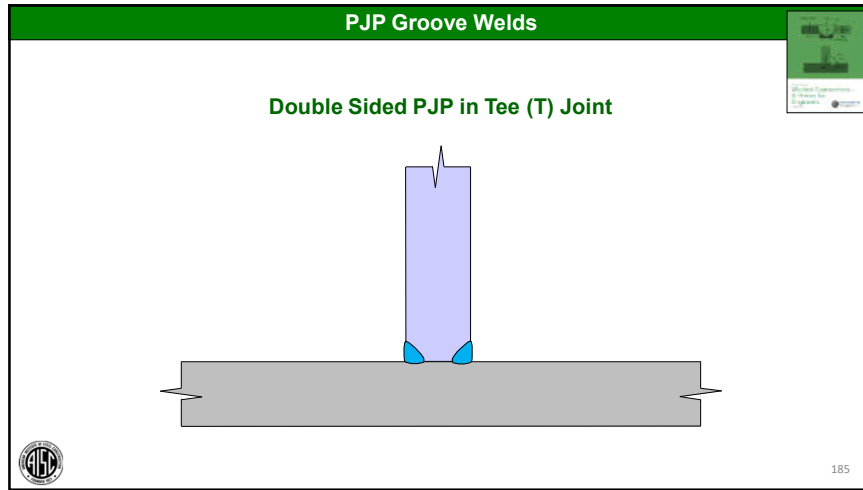





### PJP Groove Welds

- Throat < plate thickness
- Must determine throat



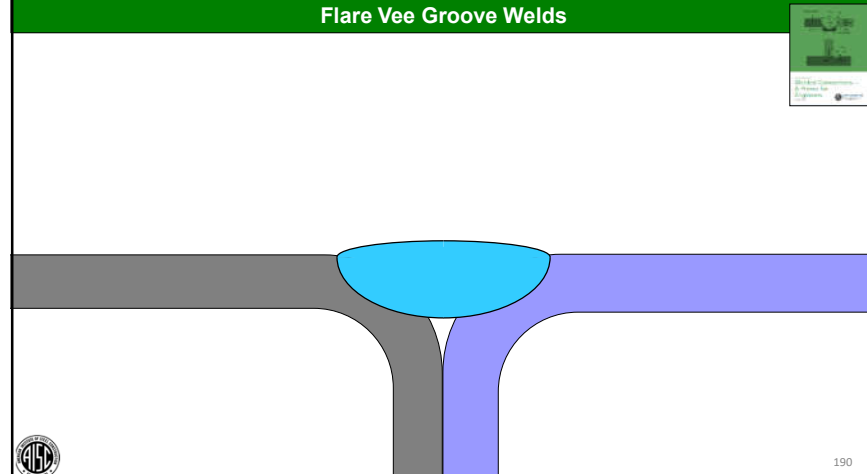

189

### Flare Vee Groove Welds



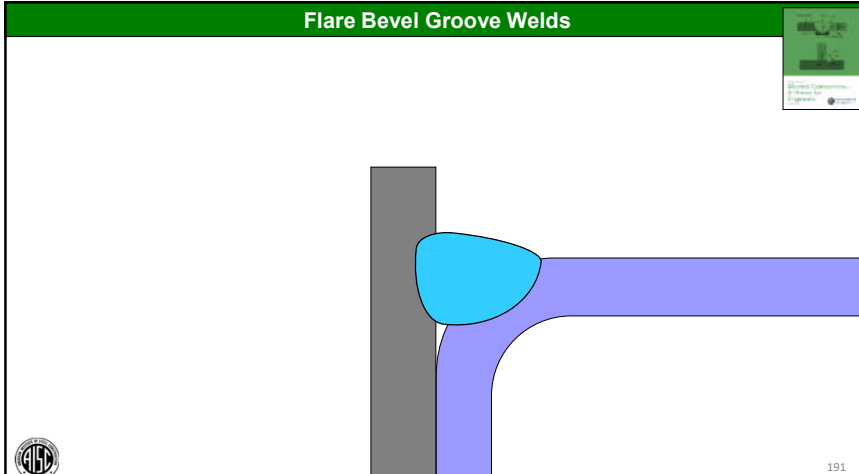

190

### Flare Bevel Groove Welds



191

### Fillet Welds

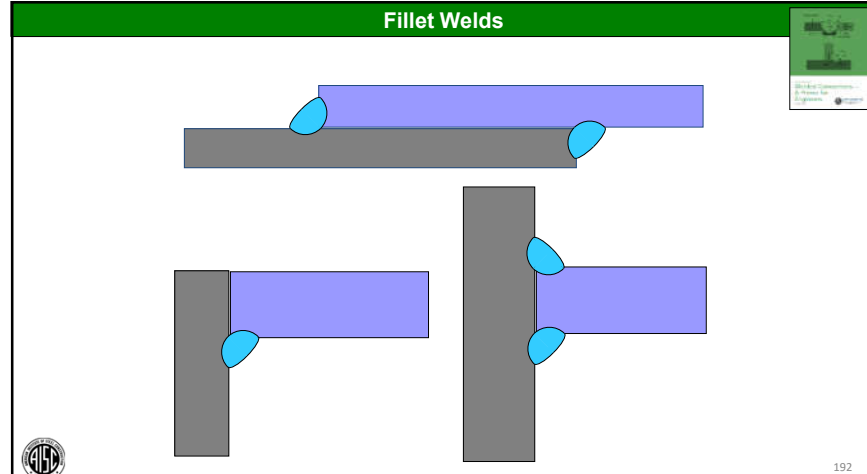

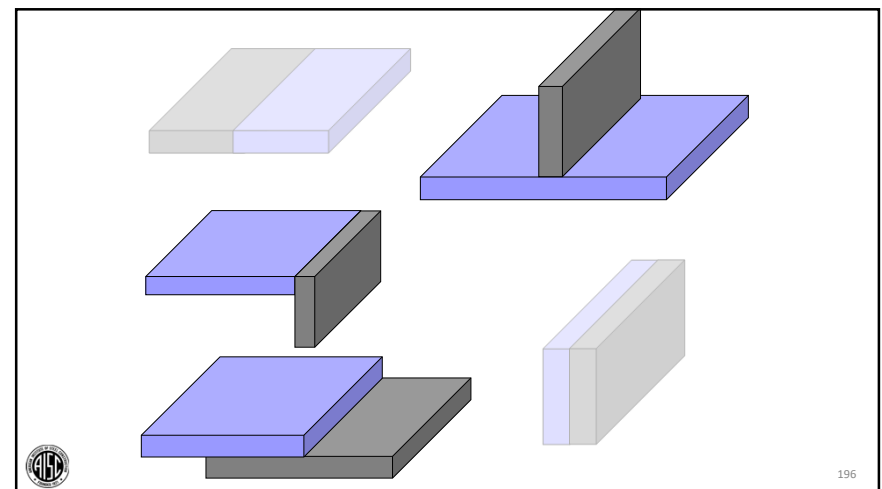
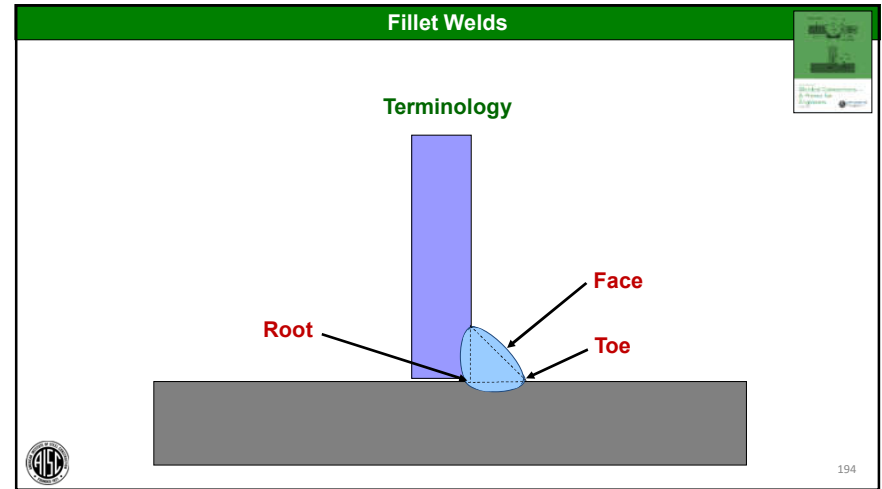
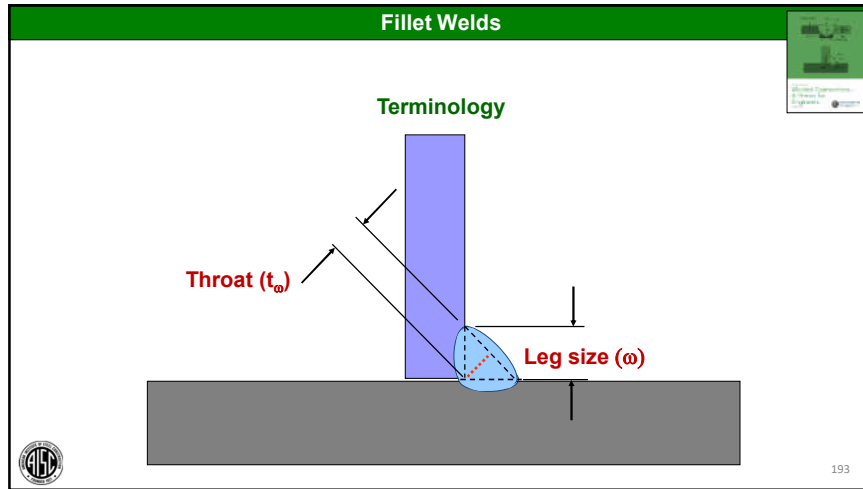

192





### Fillet Welds

- Applied to tee, corner, lap joints
- Specify leg (throat) dimension
- Specify length



197

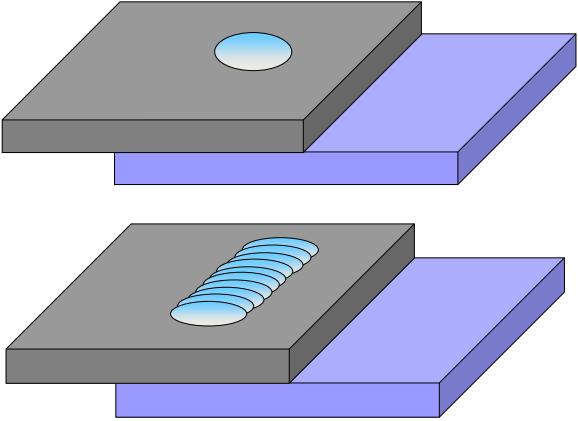

### Plug and Slot Welds





198

### Plug and Slot Welds

- Applied to lap joints



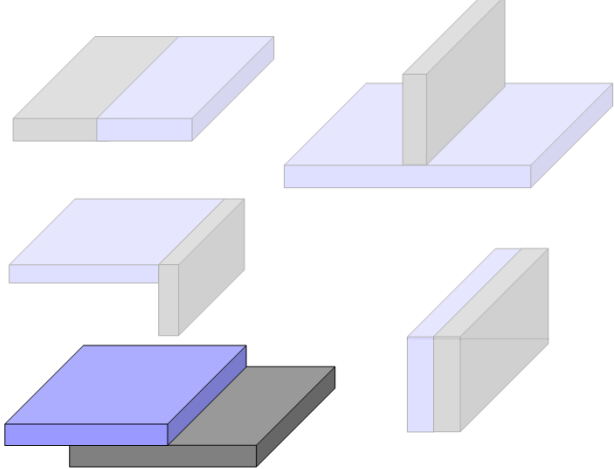

199



200

### Plug and Slot Welds

- Applied to lap joints
- Not often applied in structures
- Restricted capacity in cyclically loaded structures



201

### WELDED CONNECTION BASICS

#### Outline

- Applicable Codes
- Arc Welding Processes – Overview
- Welding and Thermal Cutting Processes
- Joints and Weld Types



202

# Thank you!

**AISC** | Questions



**Smarter.  
Stronger.  
Steel.**

## Individual Session Registrants

### PDH Certificates

- All WFH individuals associated with a group registration will be issued a certificate.
- All individuals attending at your connection: you will receive an email on how to report their attendance from: [registration@aisc.org](mailto:registration@aisc.org).
  - Be on the lookout: Check your spam filter! Check your junk folder!
  - Completely fill out online form. Don't forget to check the boxes next to each attendee's name!



## 8-Session Registrants

### PDH Certificates

One certificate will be issued at the conclusion of all 8 sessions.



## 8-Session Registrants

### Access to the quiz

Information for accessing the quiz will be emailed to you by Thursday. It will contain a link to access the quiz. EMAIL COMES FROM [NIGHTSCHOOL@AISC.ORG](mailto:NIGHTSCHOOL@AISC.ORG).

### Quiz and attendance records

Posted Thursday mornings. [www.aisc.org/nightschool](http://www.aisc.org/nightschool) -- Click on Current Course Details.

### Reasons for quiz

- EEU – You must take all quizzes and the final exam to receive EEU.
- PDHs – If you watch a recorded session, you must pass quiz for PDHs.
- REINFORCEMENT – Reinforce what you learn tonight. Get more out of the course.

*Note: If you attend the live presentation, you do not have to take the quizzes to receive PDHs*



## 8-Session Registrants

### Access to the recording

Information for accessing the recording will be emailed to you by Thursday. The recording will be available for four weeks. (For 8-session registrants only.) EMAIL COMES FROM [NIGHTSCHOOL@AISC.ORG](mailto:NIGHTSCHOOL@AISC.ORG).

### PDHs via recording

If you watch a recorded session, you must take *and pass* the quiz for PDHs.



## 8-Session Registrants

### Night School Resources

Find all your handouts, quizzes and quiz scores, recording access, and attendance information all in one place!



## 8-Session Registrants

### Night School Resources

Go to [www.aisc.org](http://www.aisc.org) and sign in.

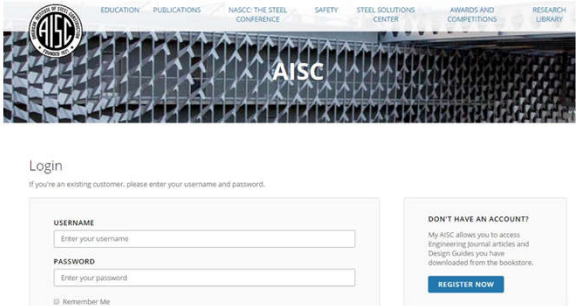

The screenshot shows the AISC website home page with navigation tabs for Education, Publications, NASCC: The Steel Conference, Safety, Steel Solutions Center, Awards and Competitions, and Research Library. Below the navigation is a large banner image of a steel structure with the AISC logo. Underneath the banner is a login section with fields for Username and Password, and a 'REGISTER NOW' button for new users.

## 8-Session Registrants

### Night School Resources

Go to [www.aisc.org](http://www.aisc.org) and sign in.

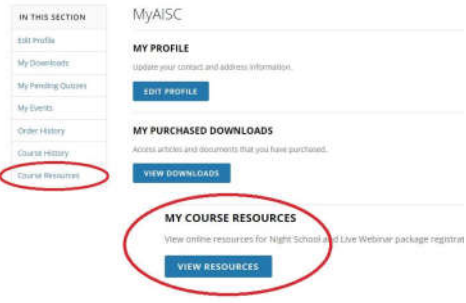

The screenshot shows the MyAISC user profile page. On the left is a sidebar menu with 'Course Resources' circled in red. The main content area has sections for 'MY PROFILE', 'MY PURCHASED DOWNLOADS', and 'MY COURSE RESOURCES'. The 'MY COURSE RESOURCES' section has a 'VIEW RESOURCES' button circled in red.

## 8-Session Registrants

### Night School Resources

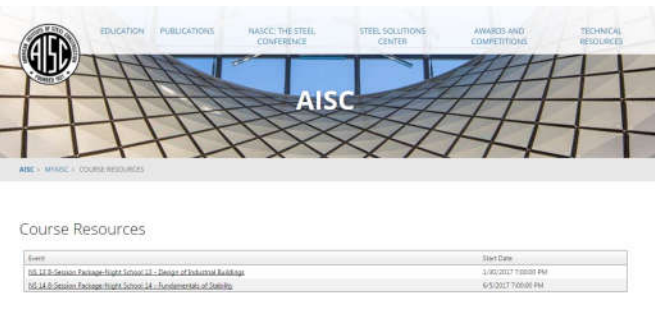

The screenshot shows the 'Course Resources' section of the AISC website. It features a navigation bar with tabs for Education, Publications, NASCC: The Steel Conference, Steel Solutions Center, Awards and Competitions, and Technical Resources. Below the navigation is a large banner image of a steel structure with the AISC logo. Underneath the banner is a table of course resources.

Event	Start Date
NS 13 8-Session Package Night School 13 - Design of Industrial Buildings	3/05/2017 7:00:00 PM
NS 14 8-Session Package Night School 14 - Fundamentals of Bolting	6/5/2017 7:00:00 PM

## 8-Session Registrants

### Night School Resources

#### Night School 13: Design of Industrial Buildings

##### 8-SESSION PACKAGE RESOURCES

Event	Date	Hours	Video	Quiz	Attendance
NS13 - Design Criteria	3/30/2017 7:00:00 PM	1.00	Yes	Pass	Pending
NS13 - Economic Considerations	2/6/2017 7:00:00 PM	1.00	Yes	Pass	Pending
NS13 - Lateral Load Systems and Details	3/13/2017 7:00:00 PM	1.00	Yes	Pass	Pending
NS13 - Preliminary Design Procedures	3/27/2017 7:00:00 PM	1.00	Yes	Pass	Pending
NS13 - Crane Order Design and Frame Analysis	3/6/2017 7:00:00 PM	1.00	Yes	Pass	Pending
NS13 - Frame Member and Connection Design	3/13/2017 7:00:00 PM	1.00	Yes	Pass	Pending
NS13 - Transfer Crane Girders to Composite Beams	3/27/2017 7:00:00 PM	1.00	Yes	Pass	Pending
NS13 - Building Envelope and Bracing Design	4/20/2017 7:00:00 PM	1.00	Yes	Pass	Pending

## 8-Session Registrants

### Night School Resources

- Weekly “quiz and recording” email.
- Weekly updates of the master quiz and attendance record, found at [www.aisc.org/nightschool26](http://www.aisc.org/nightschool26). Scroll down to Quiz and Attendance records.
  - Updated on Friday mornings.



## 8-Session Registrants

### Night School Resources

- Webinar connection information
  - Reminder email sent out Tuesday mornings
- Links to handouts also found here

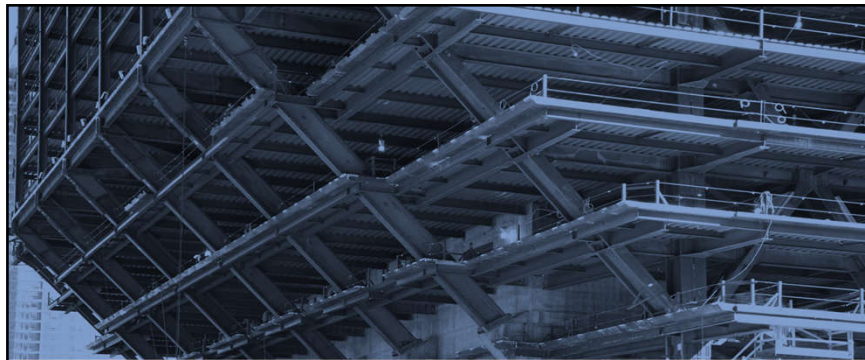

**AISC** | Thank you

