



**Night School 27:
Fundamentals of
Welding and Bolting**

Thank you for joining our live webinar. We will begin shortly. Please standby.

Session 2 – Principles of Welded Connections
October 4, 2021 | Curtis Decker



Smarter.
Stronger.
Steel.

AISC Live Webinars

Today's live webinar will begin shortly. Please stand by.

Today's audio will be broadcast through the internet. Please be sure to turn up the volume on your speakers.

Please type any questions or comments in the Q&A window.



AISC Live Webinars

AIA Credit

AISC is a Registered Provider with The American Institute of Architects Continuing Education Systems (AIA/CES). Credit(s) earned on completion of this program will be reported to AIA/CES for AIA members. Certificates of Completion for both AIA members and non-AIA members are available upon request.

This program has been submitted for AIA/CES for continuing professional education. As such, it does not include content that may be deemed or construed to be an approval or endorsement by the AIA of any material or product, or any method or manner of handling, using, distributing, or dealing in any material or product.

Questions related to specific materials, methods, and services will be addressed at the conclusion of this presentation.



AISC Live Webinars

Copyright Materials

This presentation is protected by US and International Copyright laws. Reproduction, distribution, display and use of the presentation without written permission of AISC is prohibited.

© The American Institute of Steel Construction 2021

The information presented herein is based on recognized engineering principles and is for general information only. While it is believed to be accurate, this information should not be applied to any specific application without competent professional examination and verification by a licensed professional engineer. Anyone making use of this information assumes all liability arising from such use.



AISC Live Webinars

Course Description

**NS27.2 – Welding Part 2
Principles of Welded Connections
October 4, 2021**

Following the right principles can lead to better welded connections and better projects. In this session, 14 principles of welded connection design will be presented. The principles are discussed and then illustrated with examples of connections that comply and do not comply with the concepts.



AISC Live Webinars

Learning Objectives

- Identify welded connection details that allow force to enter into the section that lies parallel.
- Identify when additional members are needed in a welded connection due to force changing direction.
- Identify situations where welds undergo bending.
- Identify preferred weld details to avoid material failures such as lamellar tearing.



Night School 27: Fundamentals of Welding and Bolting



Curtis L. Decker, PhD, PE, SE, The Lincoln Electric Company

Duane K. Miller, PE, ScD, The Lincoln Electric Company

Chad Larson, Leleune Bolt Company





Smarter. Stronger. Steel.

Night School 27: Fundamentals of Welding and Bolting

Welding Part 2: Principles of Welded Connections
October 4, 2021

Curtis L. Decker, PhD, PE, SE, The Lincoln Electric Company



Smarter. Stronger. Steel.

PRINCIPLES OF WELDED CONNECTIONS

14 Principles of Welded Connection Design

What makes a welded connection correct or proper?



PRINCIPLES OF WELDED CONNECTIONS

A correct and proper welded connection **1** is strong enough to transfer all the applied loads through the connection.

Correct and proper = strong enough (but not stronger than necessary)



PRINCIPLES OF WELDED CONNECTIONS

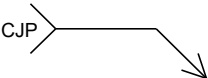

1

Official Definition:
A groove weld in which weld metal extends through the joint thickness.



PRINCIPLES OF WELDED CONNECTIONS

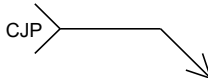

1

Unofficial Definitions:

- A weld specified J.I.C. (just in case)
- A weld specified when loads are unknown.
- A weld specified for really important connections.
- A weld specified when NDT is desired.
- A weld specified when no one wants to calculate weld size.



PRINCIPLES OF WELDED CONNECTIONS

A correct and proper welded connection is strong enough to transfer all the applied loads through the connection. **1**



13

PRINCIPLES OF WELDED CONNECTIONS

A correct and proper welded connection has a clear and direct load path. **2**

“Provide a path so a transverse force can enter that part of the member (section) that lies parallel to the force.”

Omer W. Blodgett



14

PRINCIPLES OF WELDED CONNECTIONS

A correct and proper welded connection has a clear and direct load path. **2**

“The force goes to the stiff part.”

William “Bill” A. Milek



15

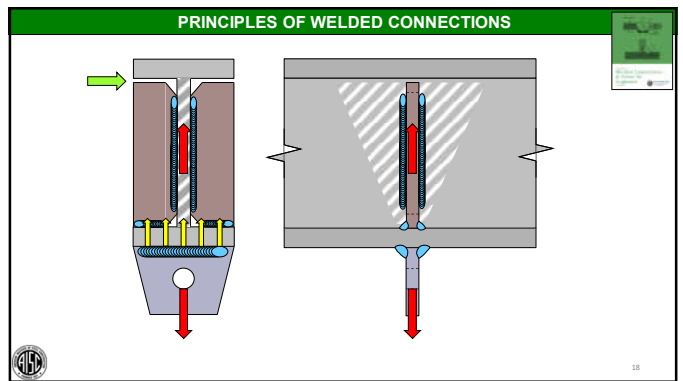
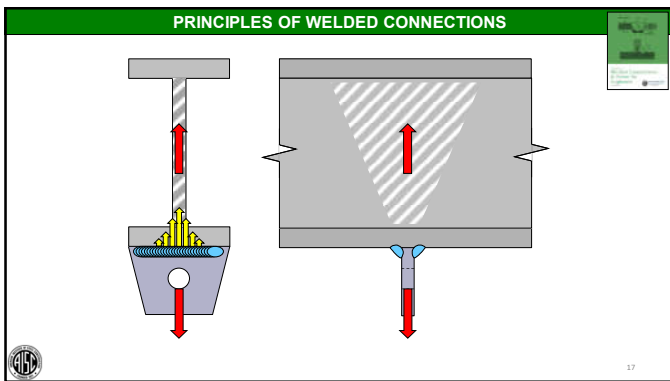
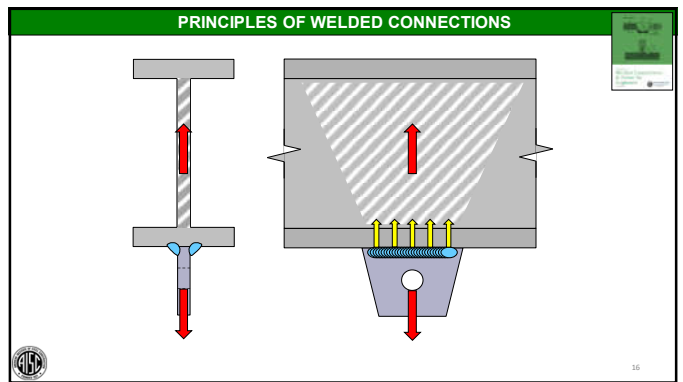

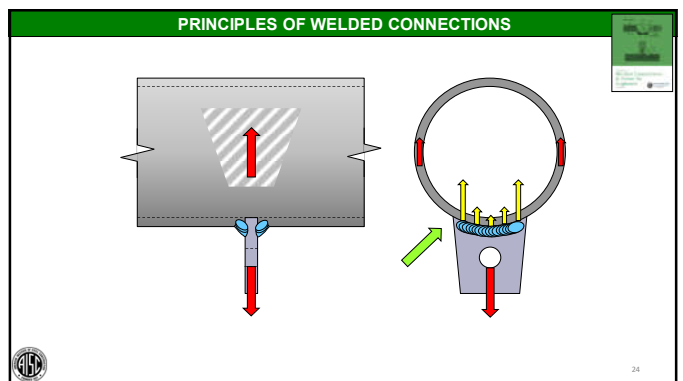
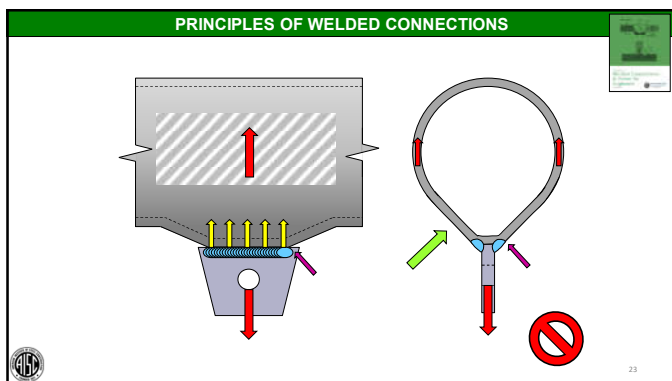
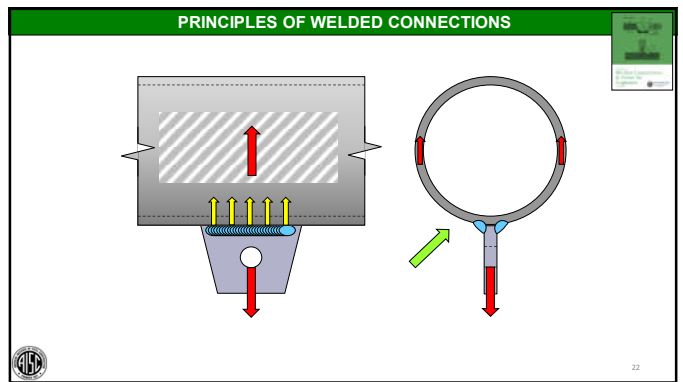
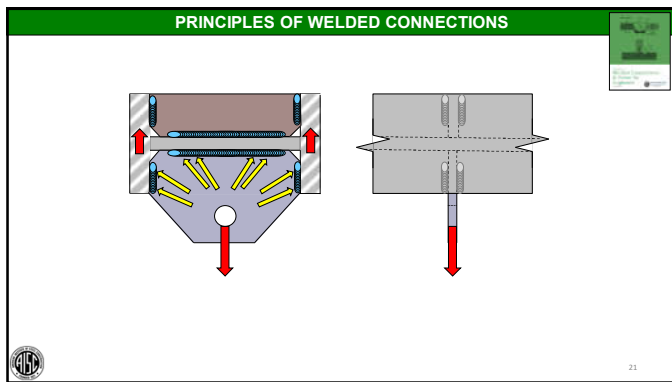
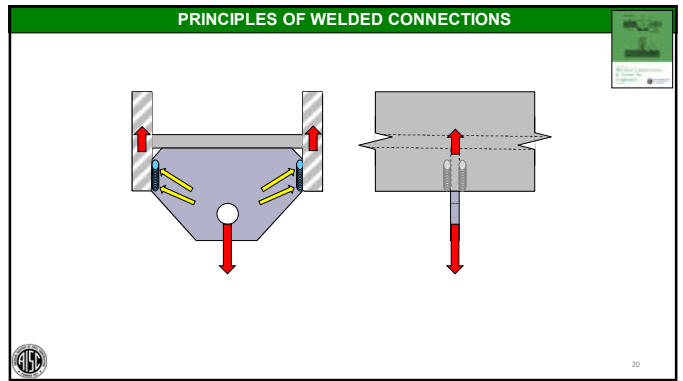
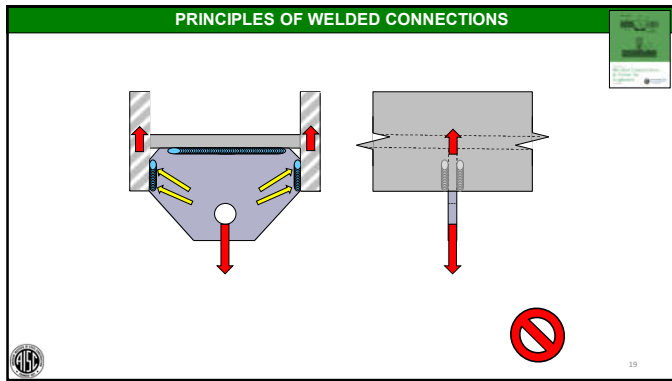

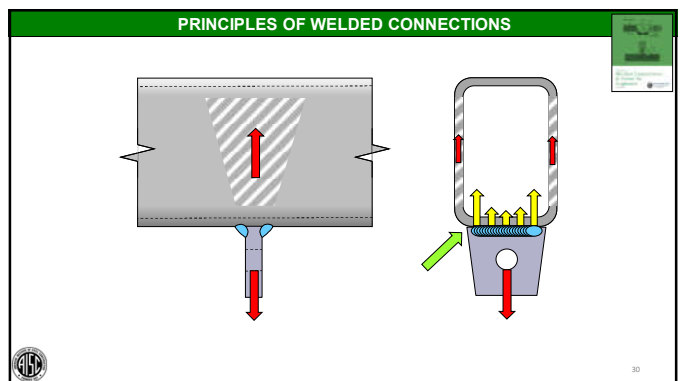
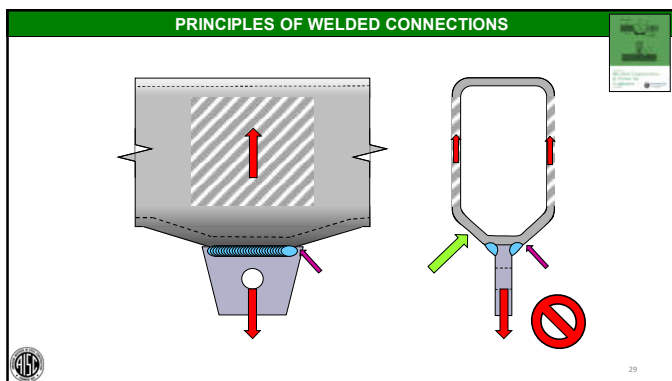
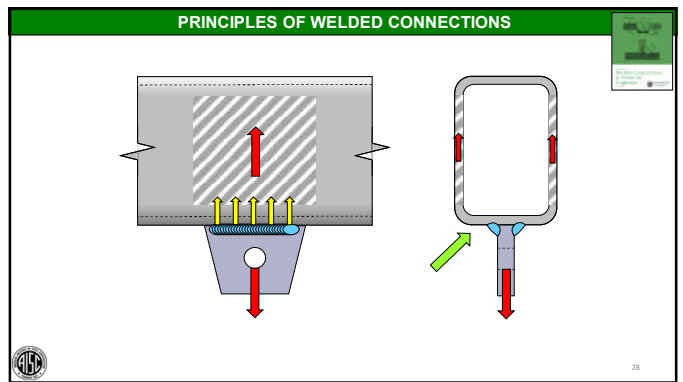
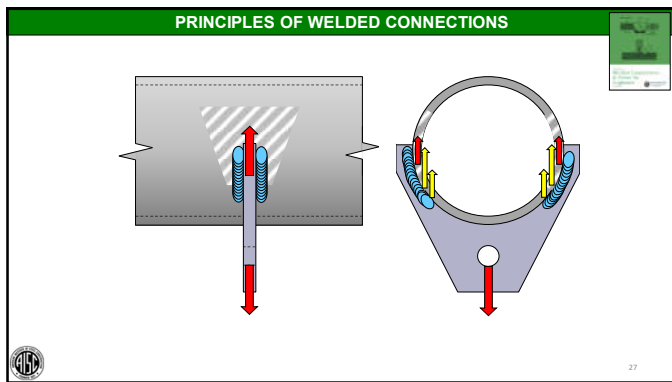
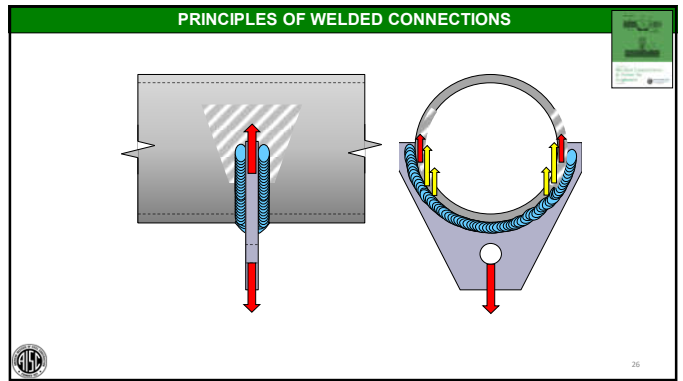
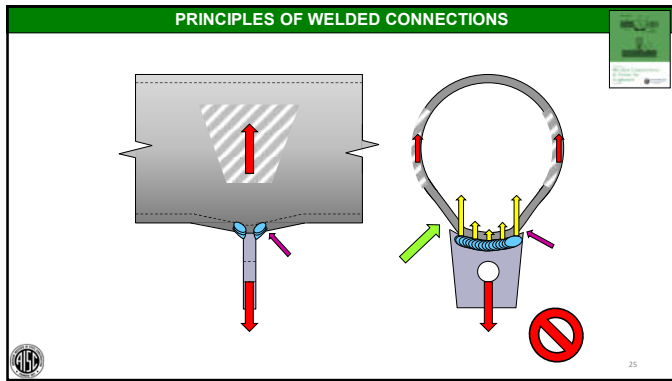

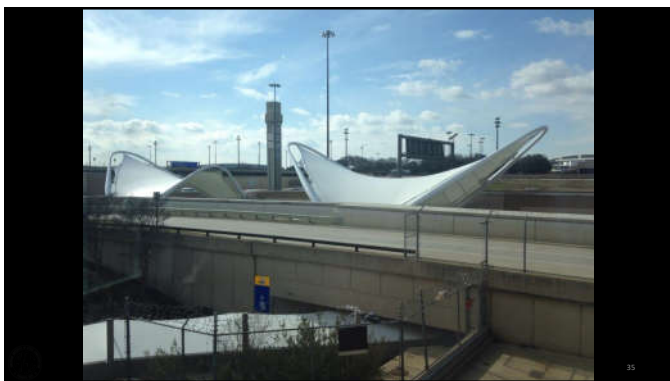
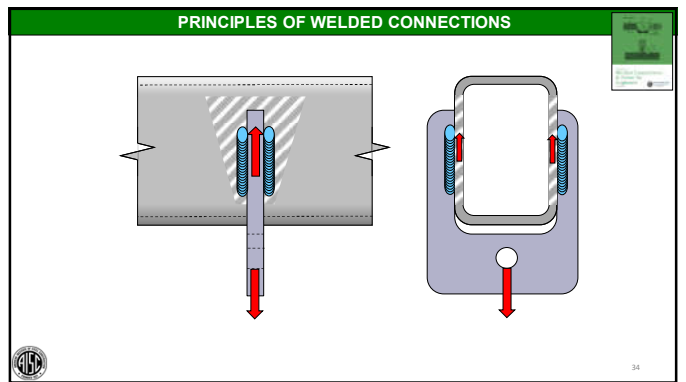
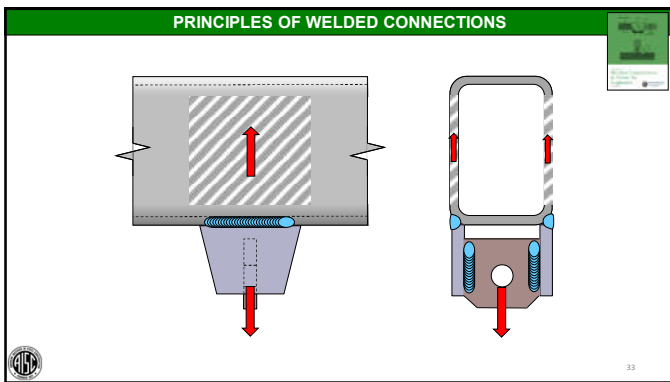
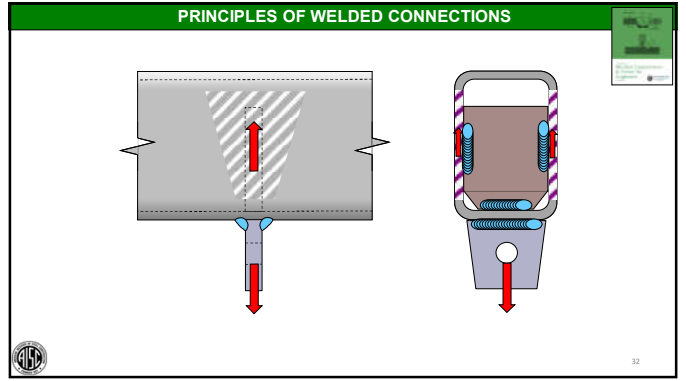
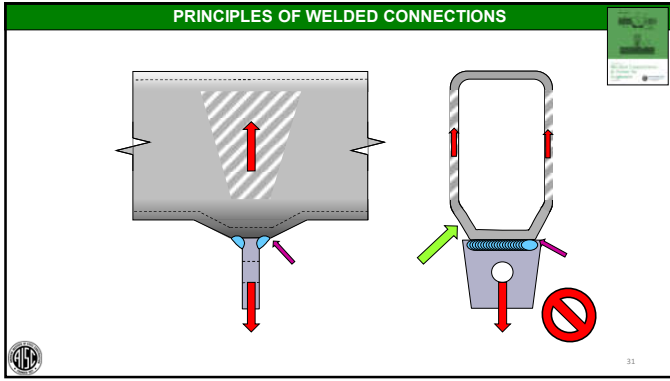





PRINCIPLES OF WELDED CONNECTIONS

A correct and proper welded connection has a clear and direct load path. 2



Note regarding HSS: the examples cited are to illustrate the load path concept. HSS connections can be successfully made in accordance with AISC 360 Chapter K through the use of design principles that consider the unique challenges of HSS.



PRINCIPLES OF WELDED CONNECTIONS

A correct and proper welded connection places welds in regions of low stress. 3

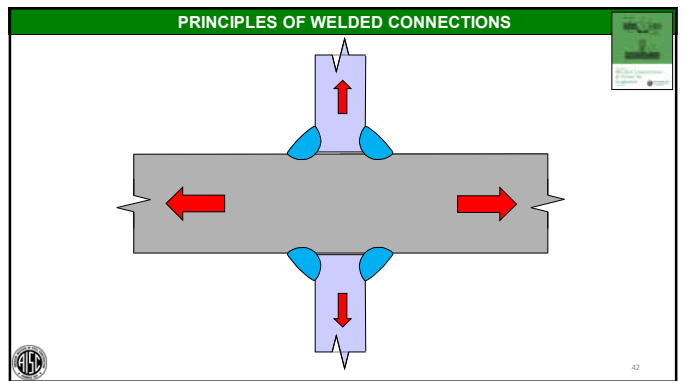
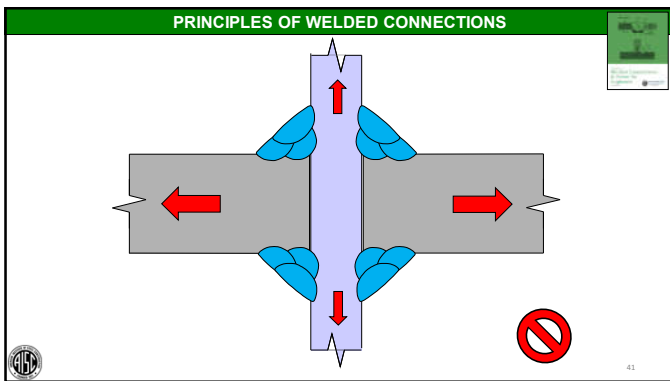
Corollary:
When possible, pass major loads through steel, not through welds



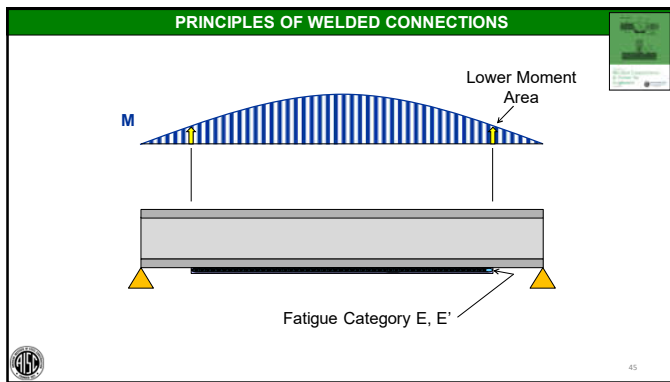
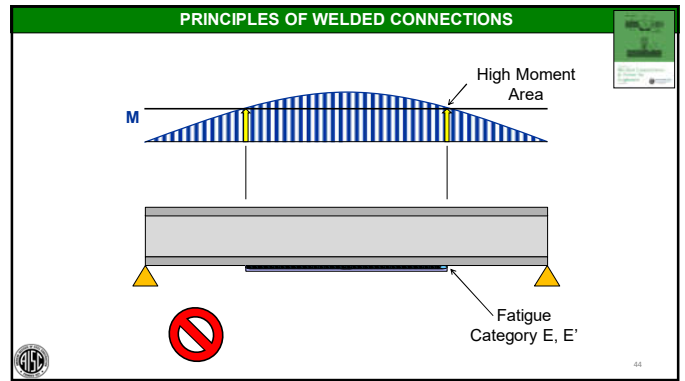
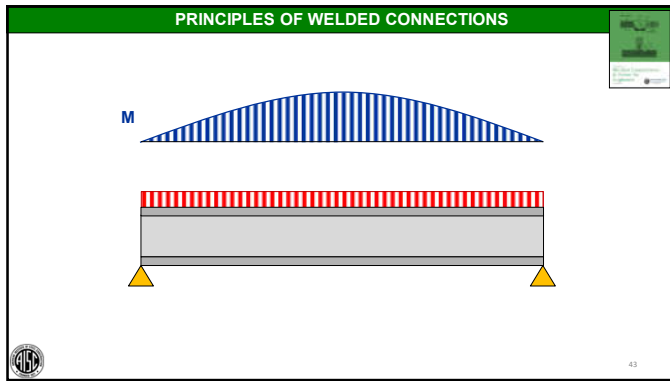

A correct and proper welded connection places welds in regions of low stress. 3

A correct and proper welded connection does not introduce stress raisers. 4

REMINDER:
Stress raisers are only stress raiser if there is a tensile stress component perpendicular to the stress raiser.

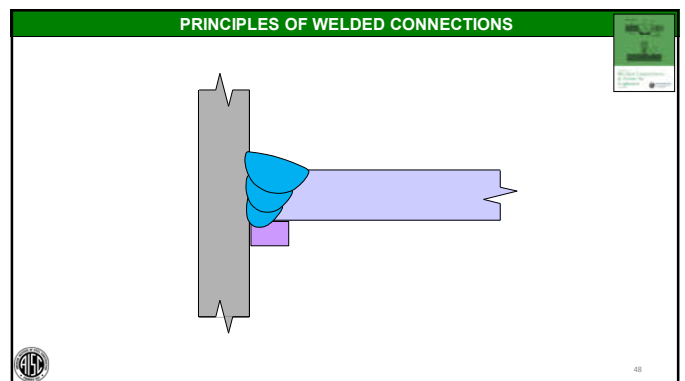

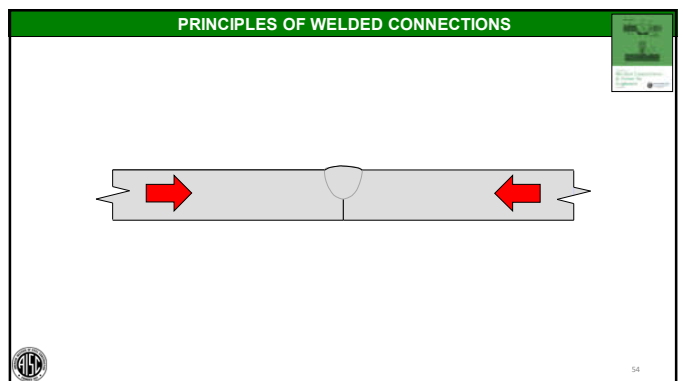
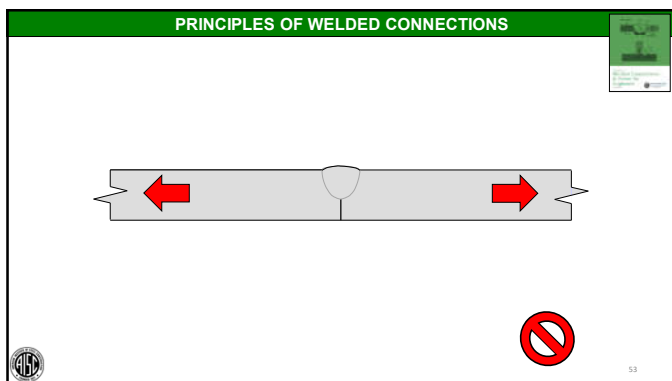
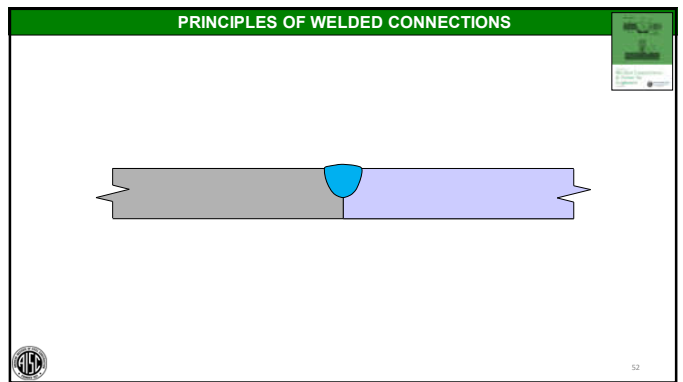
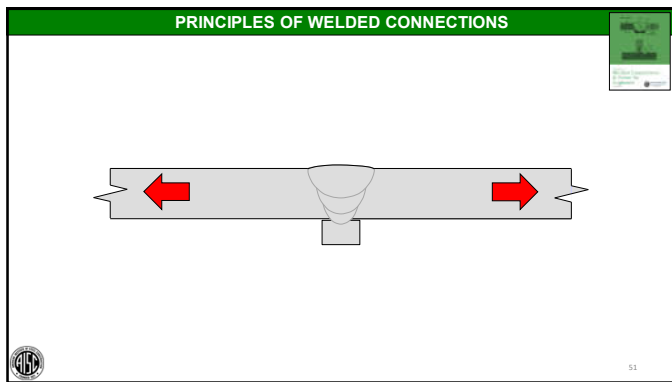
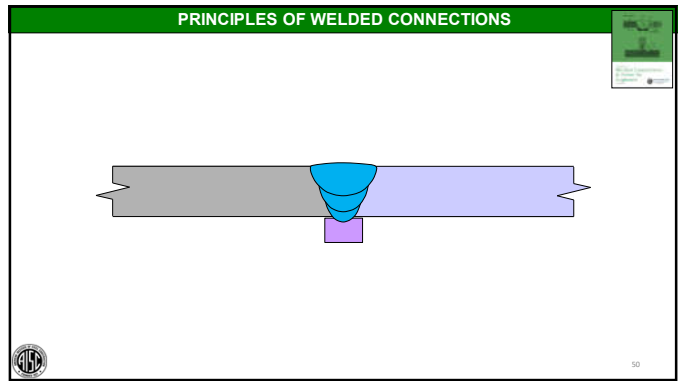
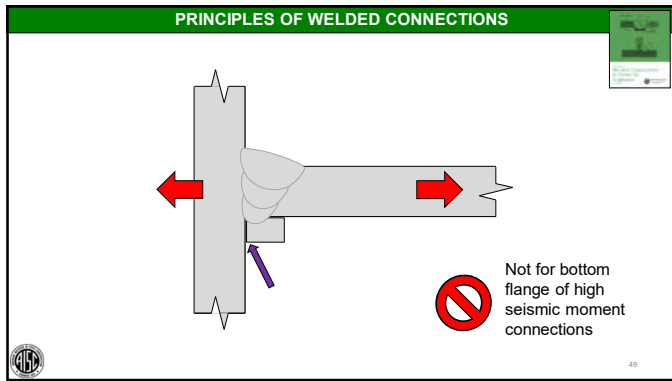

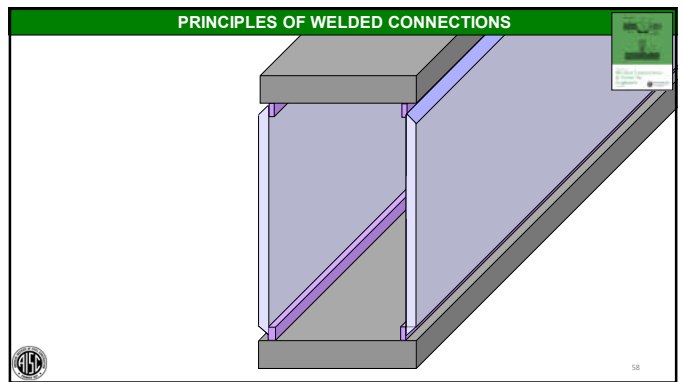
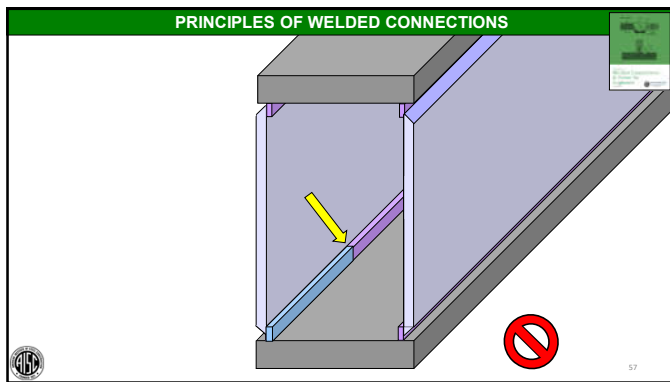
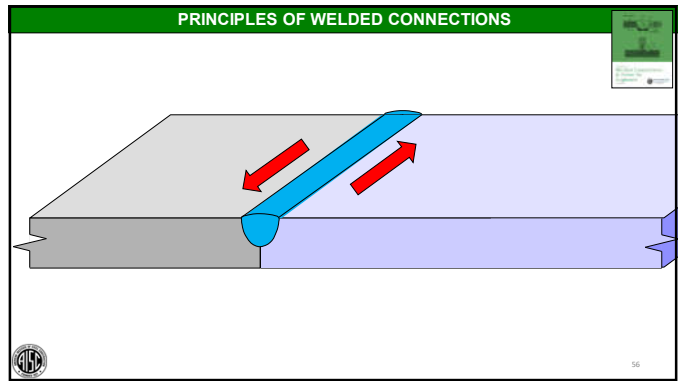
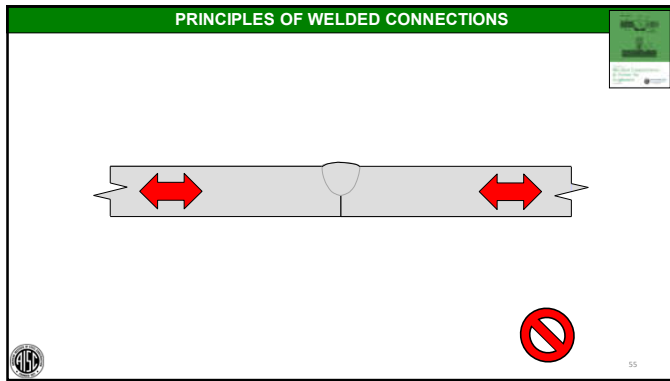

AWS D1.1: 2020 Structural Welding Code – Steel

7.9.1.2 Full-Length Backing.
Except as permitted below, steel backing shall be made continuous for the full length of the weld. All joints in the steel backing shall be CJP groove weld joints meeting all the requirements of Clause 7 of this code.

59

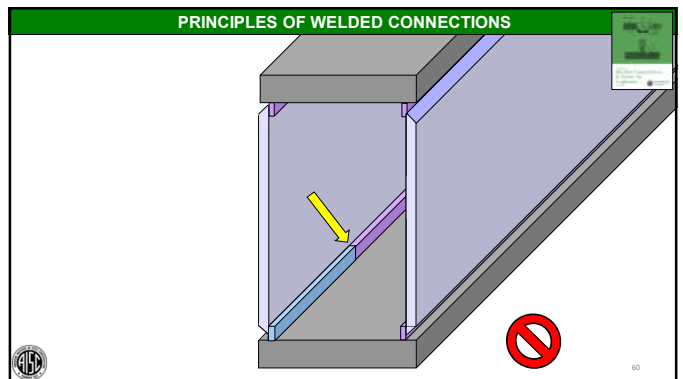

AWS D1.1: 2020 Structural Welding Code – Steel

7.9.1.2 Full-Length Backing.
Except as permitted below, steel backing shall be made continuous for the full length of the weld. All joints in the steel backing shall be CJP groove weld joints meeting all the requirements of Clause 5 of this code.



61

AWS D1.1: 2020 Structural Welding Code – Steel

7.9.1.2 Full-Length Backing.
For statically loaded applications, backing for welds to the ends of closed sections, such as hollow structural sections (HSS), are permitted to be made from one or two pieces with unspliced discontinuities where all of the following conditions are met:



62

PRINCIPLES OF WELDED CONNECTIONS

A correct and proper welded connection does not introduce stress raisers. **4**



63

PRINCIPLES OF WELDED CONNECTIONS

A correct and proper welded connection is not constrained. **5**



64



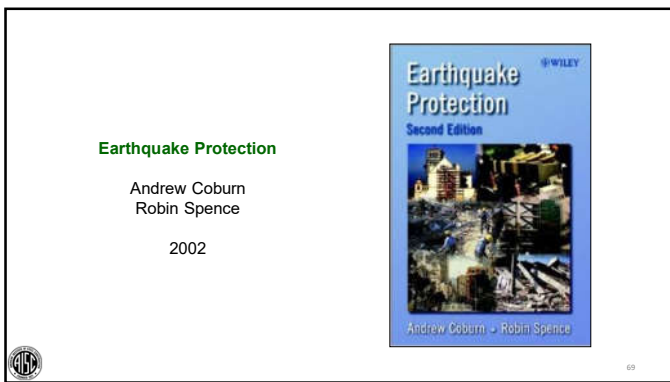
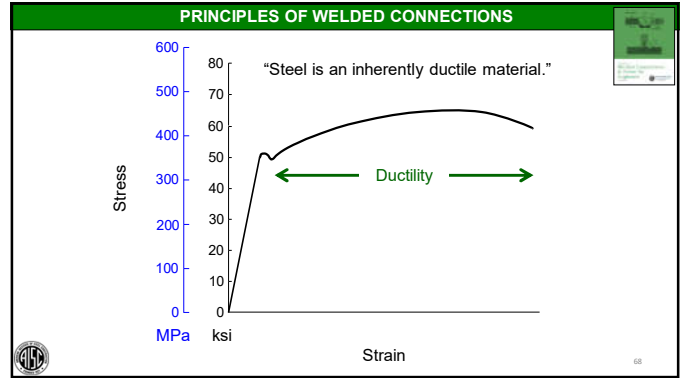

EARTHQUAKE PROTECTION

dictated by questions of availability and cost. The essential material requirements for earthquake-resistant structures are strength and ductility, and these properties are closely interrelated. *Ductility* refers to the ability of a material to deform after its maximum strength has been reached, without losing its ability to carry load. Structures made from materials which have this property can survive short-term accidental overloads because, rather than breaking, they can deform during the overload and absorb a large amount of energy without losing strength, instead of simply breaking. Steel is an inherently ductile material, and is thus very suitable for building in earthquake areas.¹⁶ California and Japan make extensive use of steel in large buildings of all types. Concrete and all types of masonry, without reinforcement, are brittle materials, but by means of embedment of steel

¹⁴ There are a wide variety of techniques which have been discussed by Key (1988) and Hanson and Seong (2001).

¹⁵ See and Spence (2009).

¹⁶ Although welded joints can be a source of weakness and have resulted in some failures in recent earthquakes.

Steel is an inherently ductile material, and is thus very suitable for building in earthquake areas.¹⁶

¹⁶Although welded joints can be a source of weakness and have resulted in some failures in recent earthquakes.

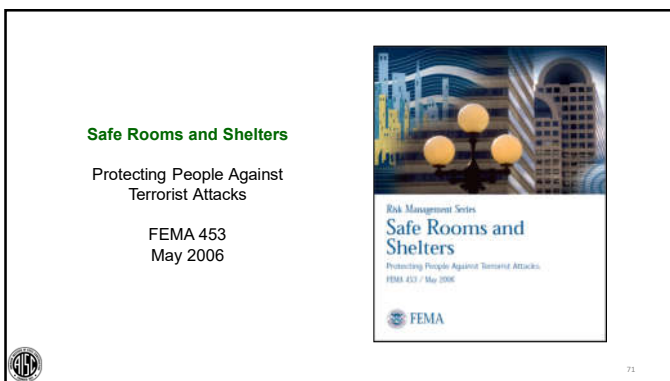

SAFE ROOMS AND SHELTERS

Steelwork is generally better suited to resist relatively low intensity, but long duration effects of large stand-off explosions. Steel is an inherently ductile material that is capable of sustaining large deformations; however, the very efficient thin-flanged sections make the conventional frame construction vulnerable to localized damage. Complex stress combinations and concentrations may occur that cause localized distress and prevent the section from developing its ultimate strength. Steel buildings may experience significant rebound and must therefore be designed to support significant rebound. Steel buildings may experience significant rebound and must therefore be designed to support significant rebound.

Steel is an inherently ductile material that is capable of sustaining large deformations; however, the very efficient thin-flanged sections make the conventional frame construction vulnerable to localized damage.

detailed to tie into the concrete slabs.

Ductile Design of Steel Structures

Preface

"Many practicing engineers have wrongly believed for years that the ductile nature of the structural steel material directly translates into inherently ductile structures."



73

Ductile Design of Steel Structures

Chapter 1 Introduction

"However, there are many situations in which an explicit approach to the design of ductile steel structures is necessary because the inherent material ductility alone is not sufficient to provide the desired ultimate performance."



74

Ductile Design of Steel Structures

Chapter 1 Introduction

"To achieve this ductile response, one must recognize and avoid conditions that may lead to brittle failures and adopt appropriate design strategies to allow for stable and reliable hysteretic energy-dissipation mechanisms. This sort of thinking is relatively new in structural engineering."



75

Fatigue and Fracture Control in Structures



Most structural materials exhibit considerable strain (deformation) before reaching the tensile or ultimate strength...However, under conditions of low temperature, rapid loading and/or high constraint (e.g., when the principle stresses σ_1 , σ_2 , and σ_3 are essentially equal), even ductile materials may not exhibit any deformation before fracture.



76

PRINCIPLES OF WELDED CONNECTIONS

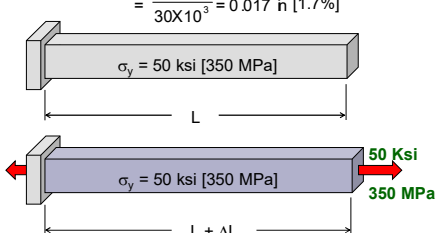
$$\Delta L = \frac{PL}{AE} = \frac{\sigma L}{E}$$



$$= \frac{50 \cdot 10}{30 \times 10^3} = 0.017 \text{ in [1.7\%]}$$



77

PRINCIPLES OF WELDED CONNECTIONS

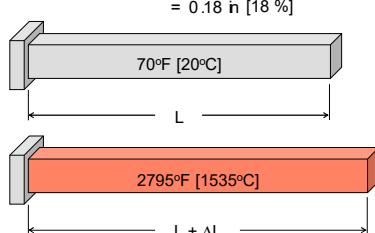
$$\Delta L = L (\Delta t)(C_{exp})$$

$$= 10 (2795 - 70)(6.6 \times 10^{-6})$$

$$= 0.18 \text{ in [18 \%]}$$

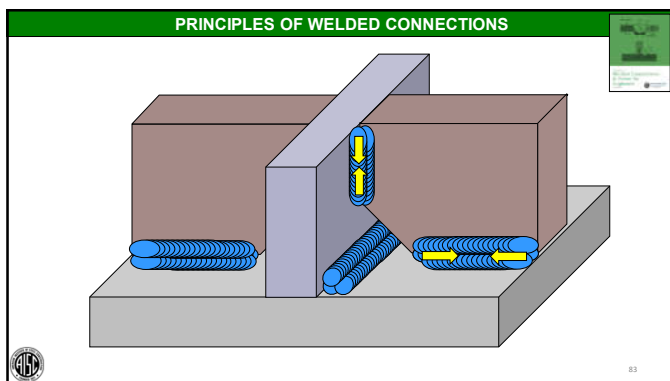
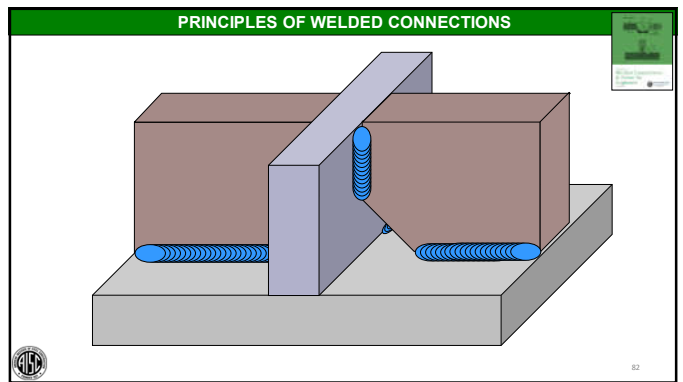
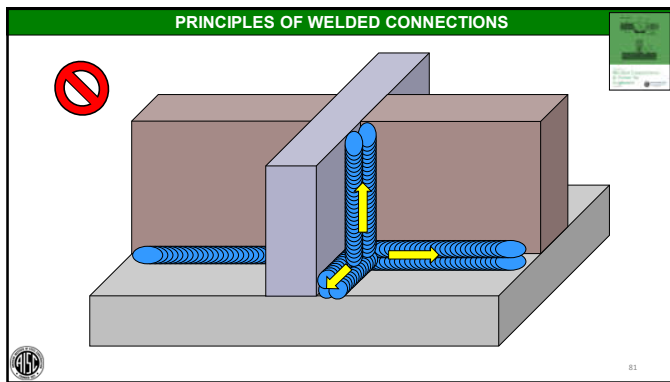
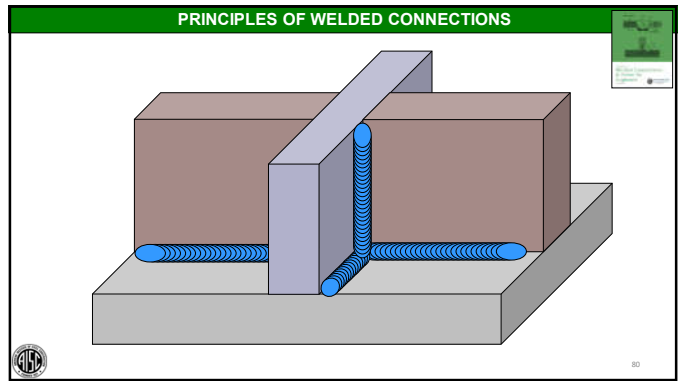
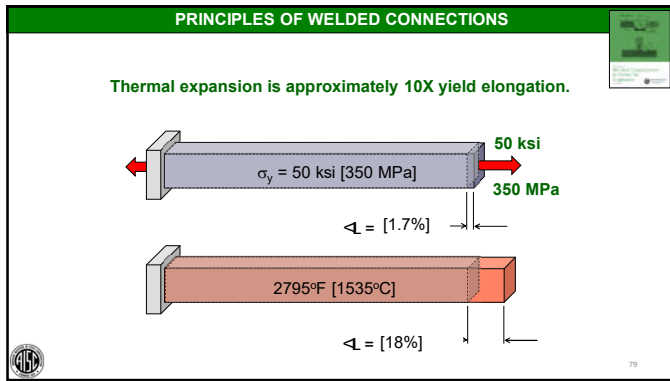

78





PRINCIPLES OF WELDED CONNECTIONS

A correct and proper welded connection is not constrained. 5



PRINCIPLES OF WELDED CONNECTIONS

A correct and proper welded connection does not subject the weld to bending about the root. **6**



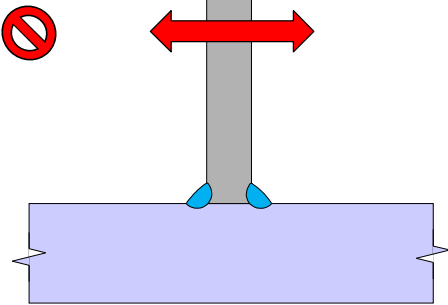

85

PRINCIPLES OF WELDED CONNECTIONS



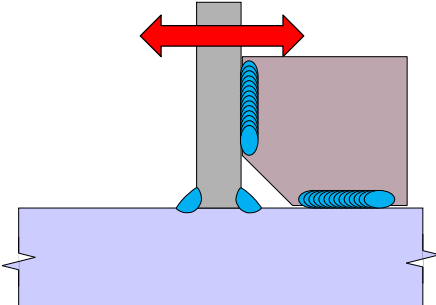

86

PRINCIPLES OF WELDED CONNECTIONS



87

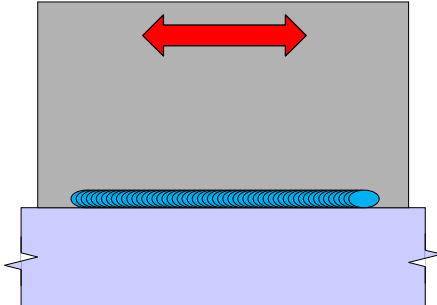

PRINCIPLES OF WELDED CONNECTIONS



88

PRINCIPLES OF WELDED CONNECTIONS

A correct and proper welded connection does not subject the weld to bending about the root. **6**





89

PRINCIPLES OF WELDED CONNECTIONS

A correct and proper welded connection protects the toes and roots of the welds. **7**

“Watch your toes
and
remember your roots.”



90

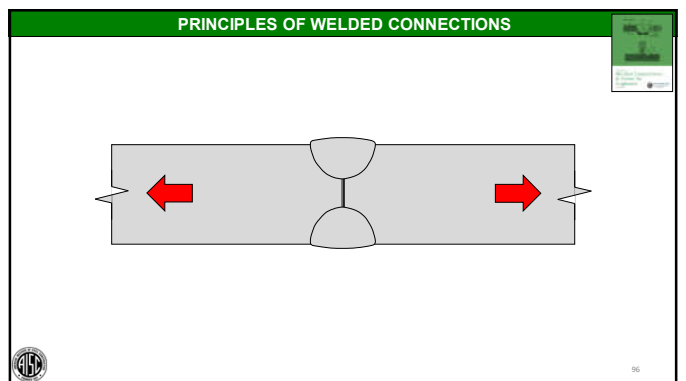
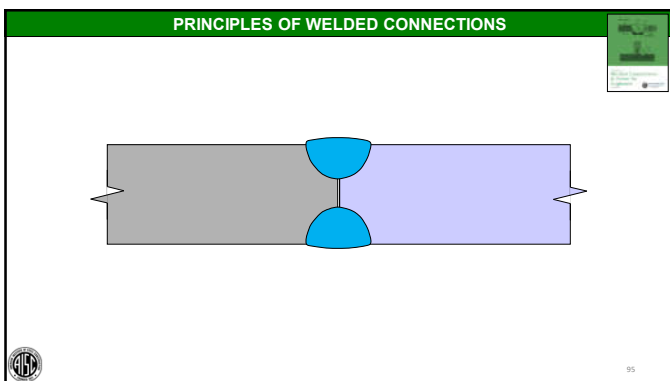
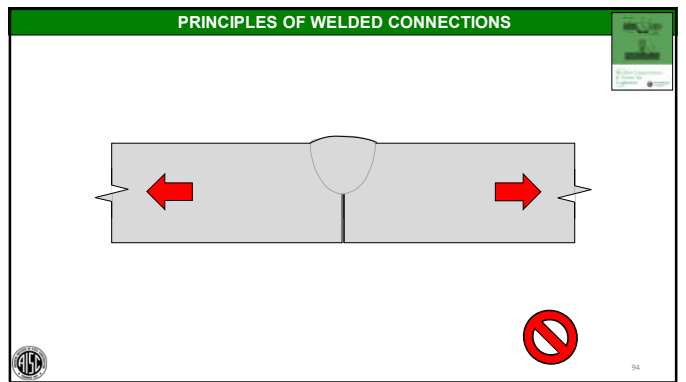
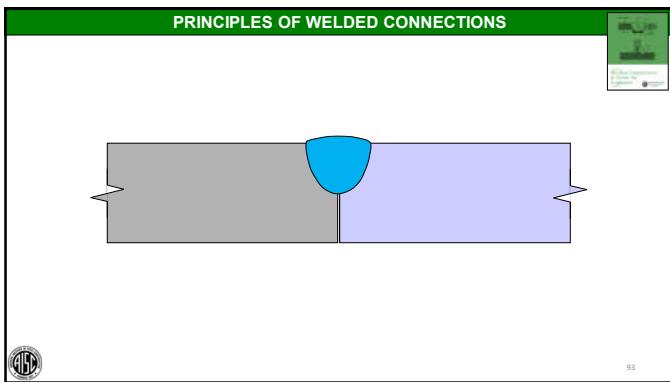
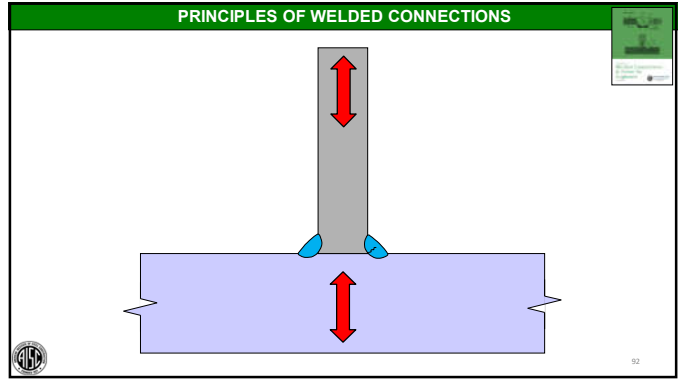
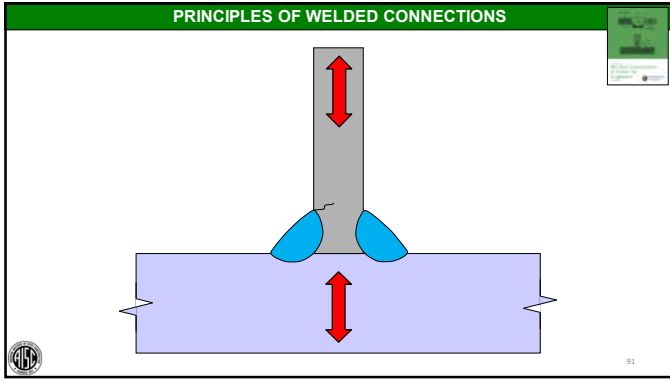

PRINCIPLES OF WELDED CONNECTIONS

A correct and proper welded connection protects the toes and roots of the welds. **7**



97

PRINCIPLES OF WELDED CONNECTIONS

A correct and proper welded connection has a clearly defined throat. **8**

“A nothin’ weld ain’t worth nothin’ ”



98

PRINCIPLES OF WELDED CONNECTIONS

nothin’ weld:
A weld that looks like what you wanted, but it ain’t.



99

PRINCIPLES OF WELDED CONNECTIONS

CJP

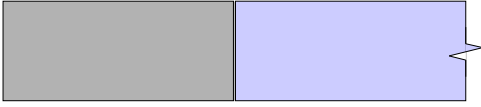

100

PRINCIPLES OF WELDED CONNECTIONS

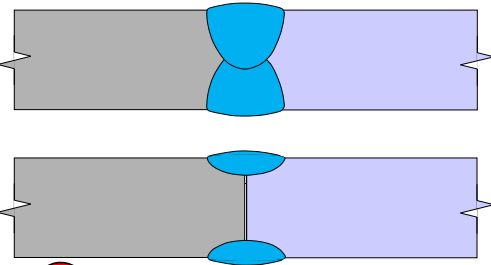

nothin’ weld:



101

PRINCIPLES OF WELDED CONNECTIONS

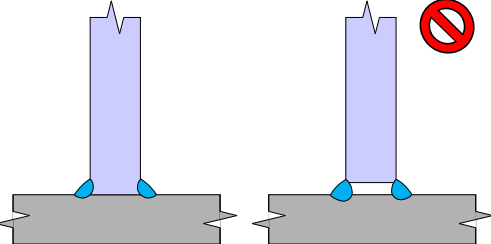

nothin’ weld:



102

PRINCIPLES OF WELDED CONNECTIONS

A correct and proper welded connection has a clearly defined throat. **8**



103

PRINCIPLES OF WELDED CONNECTIONS

A correct and proper welded connection recognizes material properties. **9**

“Respect material properties.”



104

PRINCIPLES OF WELDED CONNECTIONS

SAC Steel Project Report No. SAC/BD-97/01 Barsom and Korvink
 Through-Thickness Properties of Structural Steels



105

PRINCIPLES OF WELDED CONNECTIONS

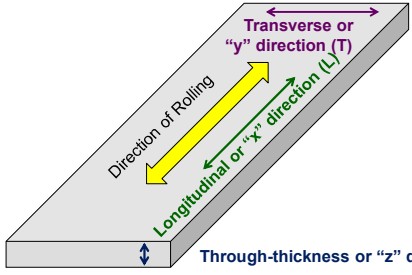

106

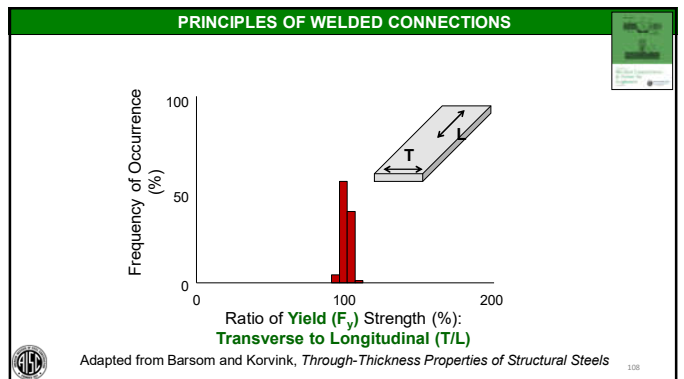
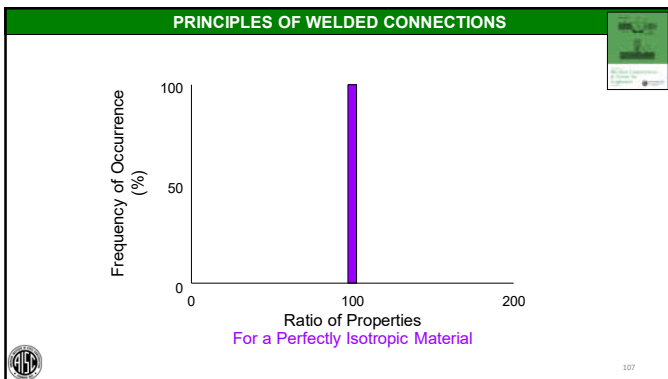

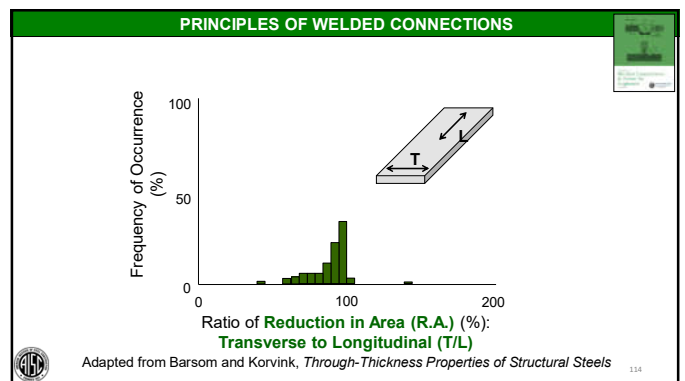
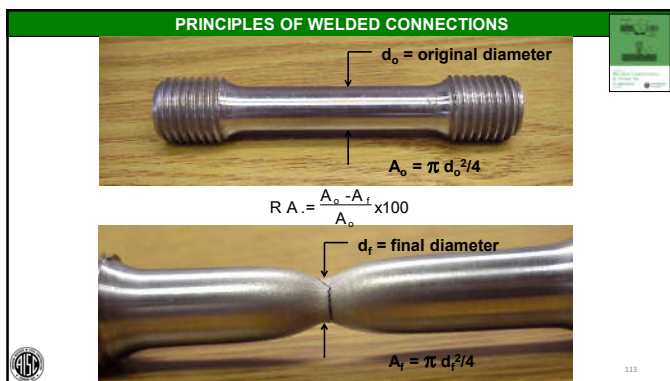
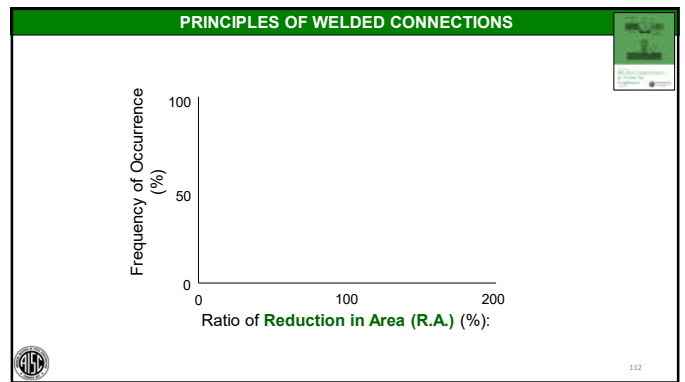
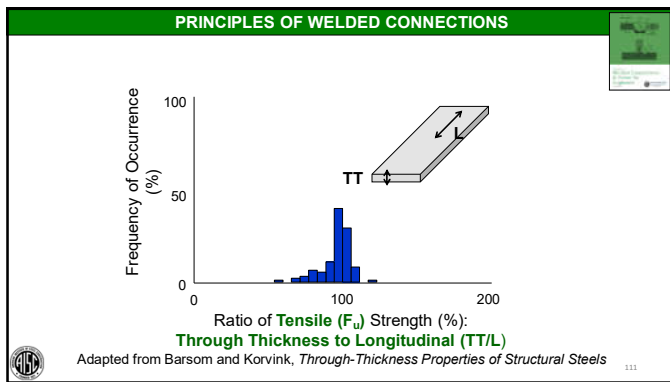
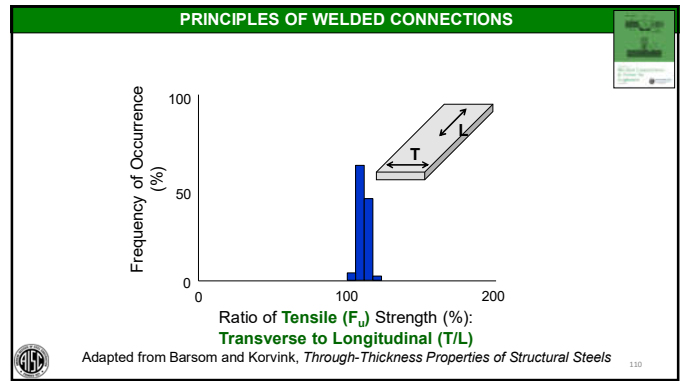
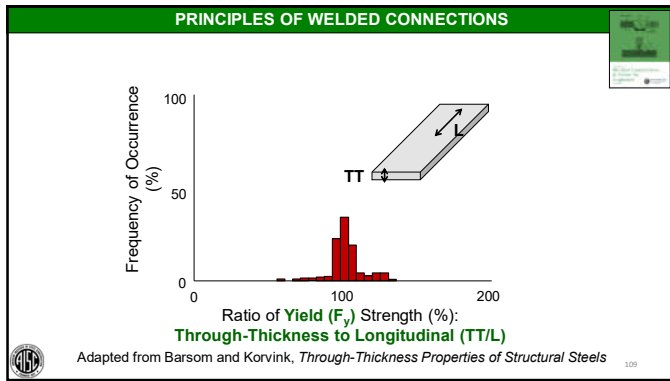

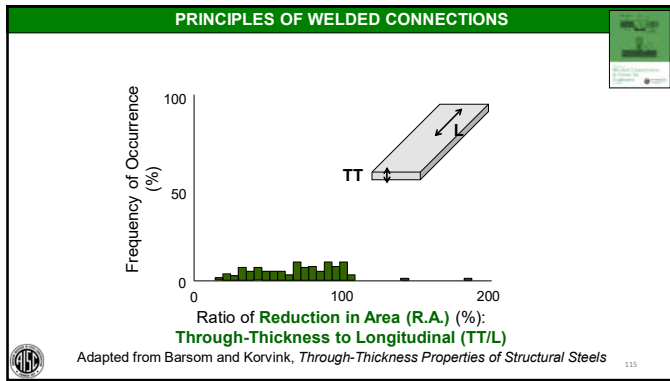

PRINCIPLES OF WELDED CONNECTIONS

SAC Report No. SAC/BD-97/01 Barsom and Korvink
 Steel Project

Through-Thickness Properties of Structural Steels

A conservative through-thickness ultimate strength value can be derived from the longitudinal values and is given by the relationship of $F_u(TT) = 0.8 F_u(L)$. Similarly, a conservative through thickness tensile yield strength value can be derived from the longitudinal values and is given by the relationship $F_y(TT) = 0.9 F_y(L)$.

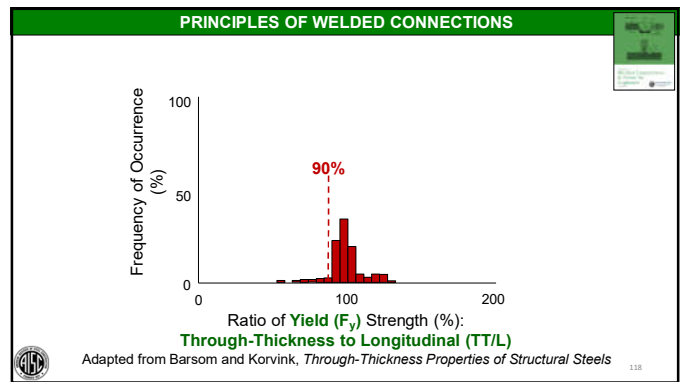
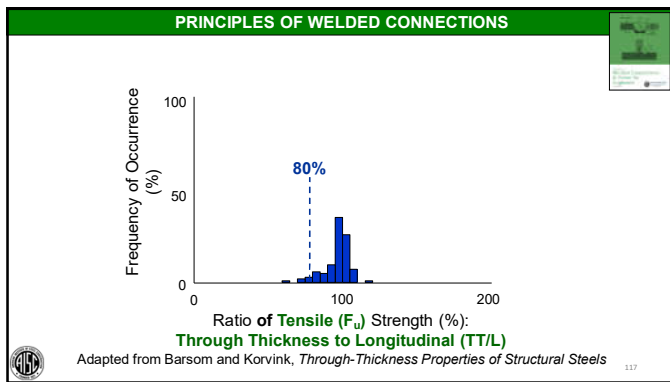

PRINCIPLES OF WELDED CONNECTIONS

SAC Report No. SAC/BD-97/01 Barsom and Korvink
 Steel Project

Through-Thickness Properties of Structural Steels

Generally, a minimum twenty percent (20%) reduction-of-area value has been used as a good measure of lamellar tearing resistance^{7,12}. However, lamellar tearing behavior of steel products is determined by a complex interaction among factors related to **material properties, detailing, welding procedure, fabrication and design.**



PRINCIPLES OF WELDED CONNECTIONS

A correct and proper welded connection recognizes material properties. 9

PRINCIPLES OF WELDED CONNECTIONS



A correct and proper welded connection is easy and economical to fabricate and erect.

10



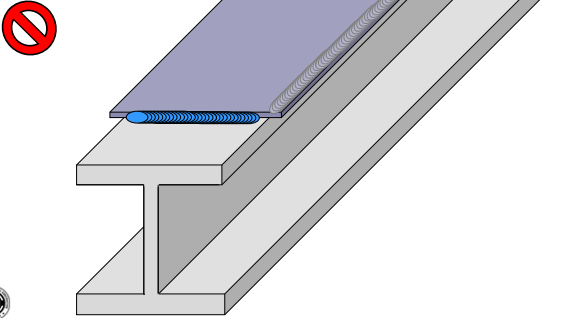

121

PRINCIPLES OF WELDED CONNECTIONS



122

PRINCIPLES OF WELDED CONNECTIONS

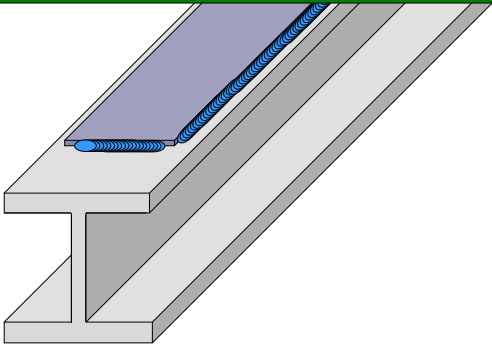



123

PRINCIPLES OF WELDED CONNECTIONS

A correct and proper welded connection is easy and economical to fabricate and erect.

10





124

PRINCIPLES OF WELDED CONNECTIONS

A correct and proper welded connection is easily inspected.



11



125

PRINCIPLES OF WELDED CONNECTIONS

The issue of inspection should be considered when details are specified. Inspection includes both visual inspection as well as nondestructive testing. On complex assemblies, subsequent welding operations may preclude inspection of previously deposited welds. For such assemblies, hold points may need to be established. Left-in-place steel backing can complicate the interpretation of NDT results.



126

PRINCIPLES OF WELDED CONNECTIONS

A correct and proper welded connection is easily inspected.

11



127

PRINCIPLES OF WELDED CONNECTIONS

A correct and proper welded connection recognizes commercial realities.

12



128

ASTM A6 Tolerances

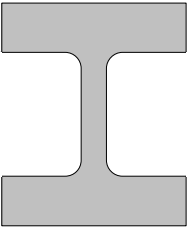

129

ASTM A6 Tolerances

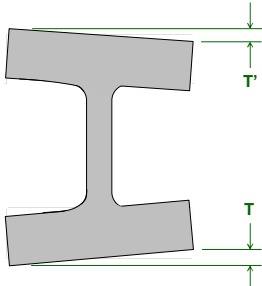

For W over 12 in, $T + T' \leq 5/16"$ [8 mm]



130

ASTM A6 Tolerances

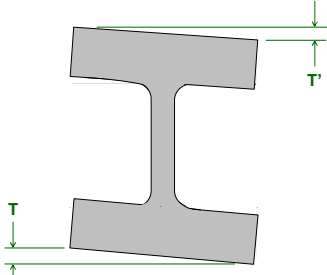

For W over 12 in, $T + T' \leq 5/16"$ [8 mm]



131

PRINCIPLES OF WELDED CONNECTIONS

Angular Distortion

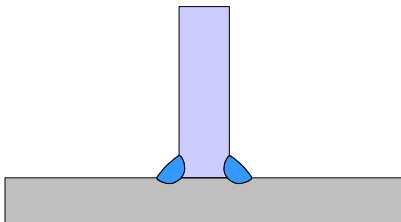

132

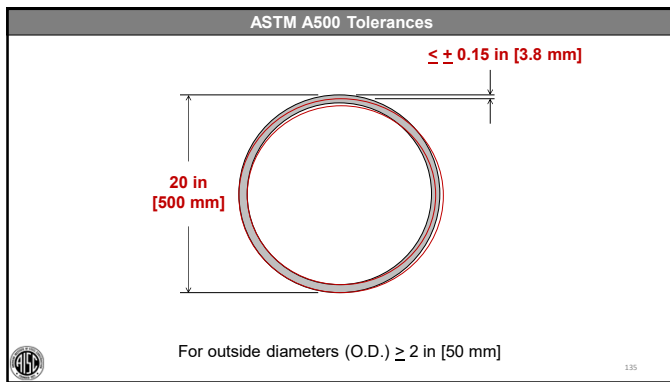
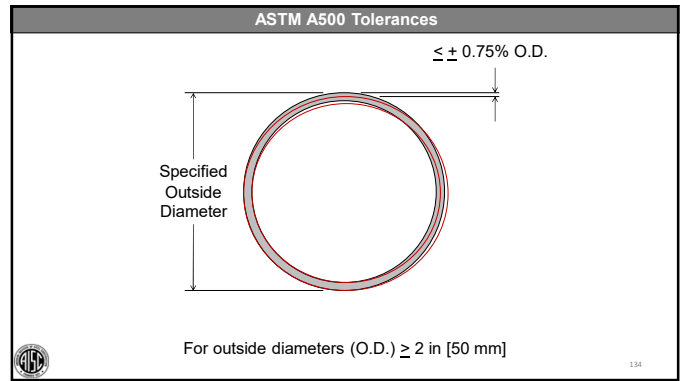
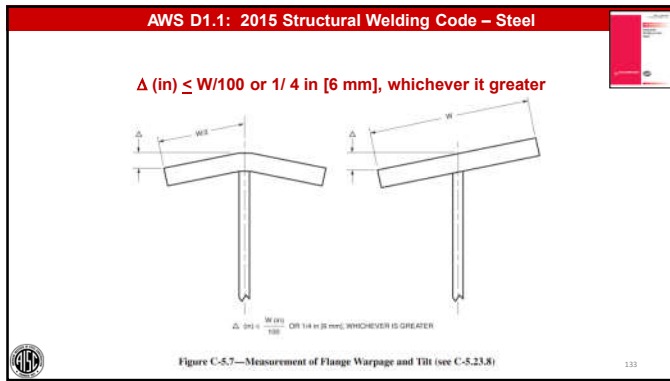

AWS D1.1: 2015 Structural Welding Code – Steel

9.24.1 Girth Weld Alignment (Tubular).
Radial offset of abutting edges of girth weld seams **shall not exceed 0.2t** (where t is the thickness of the thinner member) and the maximum allowable shall be $1/4$ in [6 mm], provided that any offset exceeding $1/8$ in [3 mm] is welded from both sides.....

Let $t = 1/2$ in [12 mm], then $0.2t = 0.10$ in [2.4 mm]

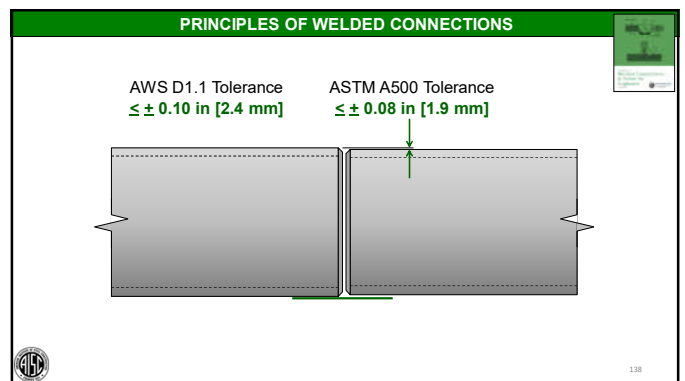
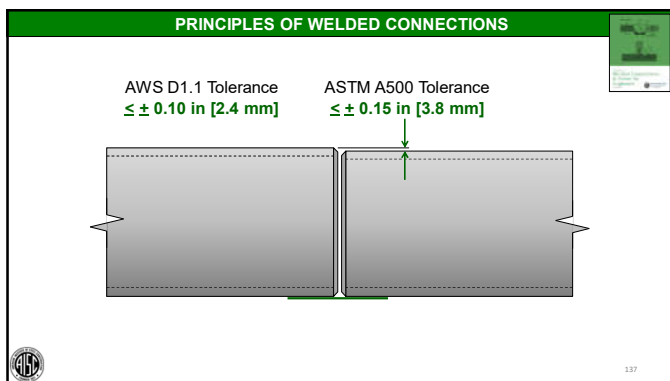

PRINCIPLES OF WELDED CONNECTIONS

A correct and proper welded connection recognizes commercial realities.

12



139

PRINCIPLES OF WELDED CONNECTIONS

A correct and proper welded connection is aesthetically pleasing.

13

Reminder:
"Beauty is in the eye of the beholder."

Reminder 2:
Sometimes, pretty doesn't really matter.



140

PRINCIPLES OF WELDED CONNECTIONS

A correct and proper welded connection is aesthetically pleasing.

"Form follows function."



141

PRINCIPLES OF WELDED CONNECTIONS

Architectural Philosophy

Form ever follows function.



Louis Henry Sullivan
Architect
1856-1924



142

PRINCIPLES OF WELDED CONNECTIONS

Louis Henry Sullivan



It is the pervading law of all things organic and inorganic,
Of all things physical and metaphysical,
Of all things human, and all things super-human,
Of all true manifestations of the head,
Of the heart, of the soul,
That the life is recognizable in its expression,
That form ever follows function. This is the law.



143

PRINCIPLES OF WELDED CONNECTIONS

Ideal



144

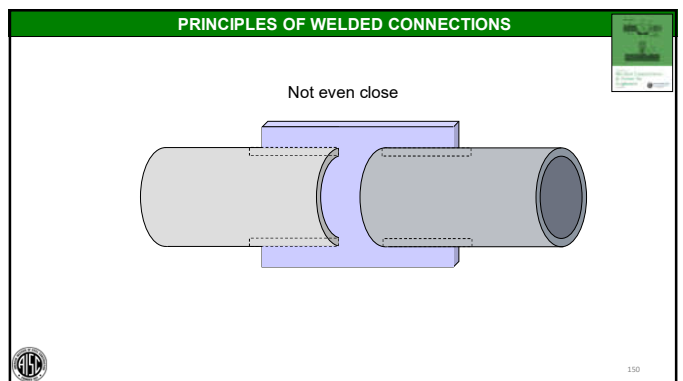
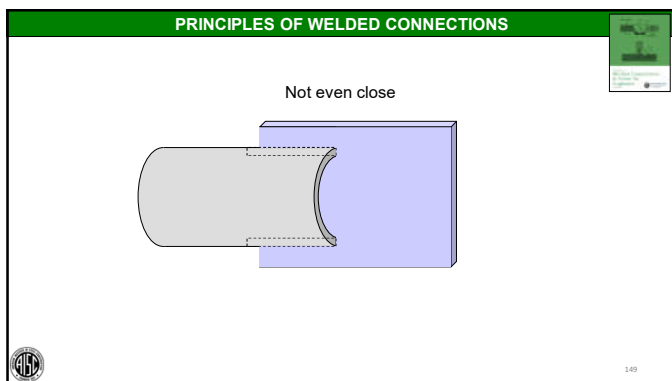
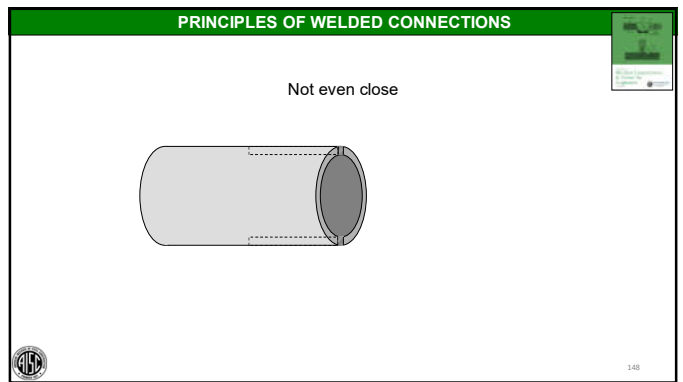
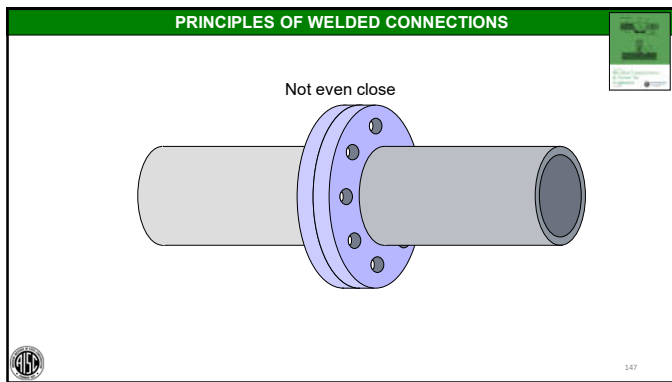
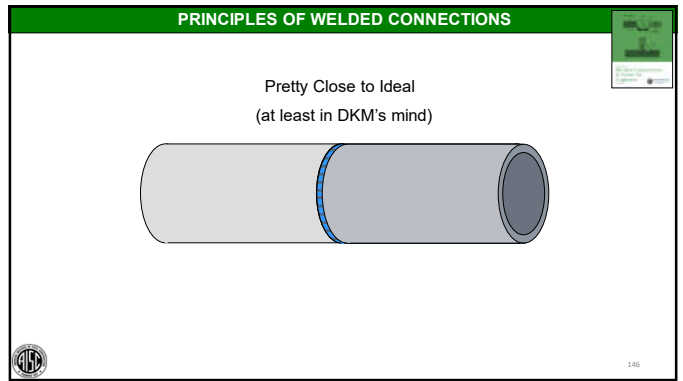
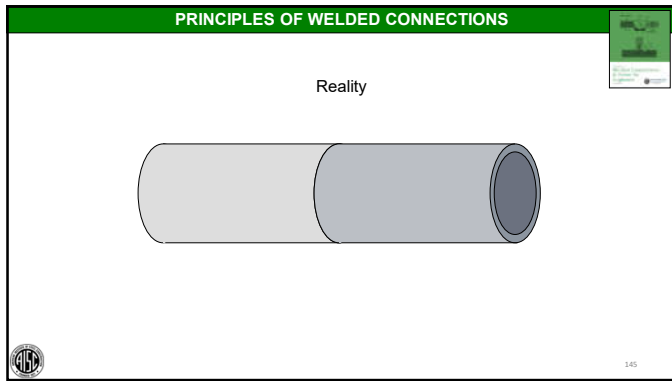

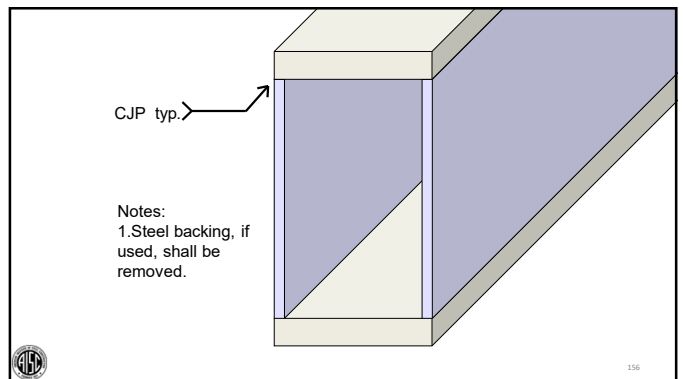
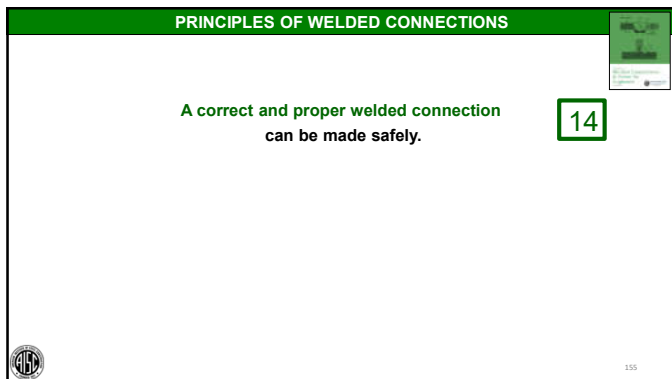
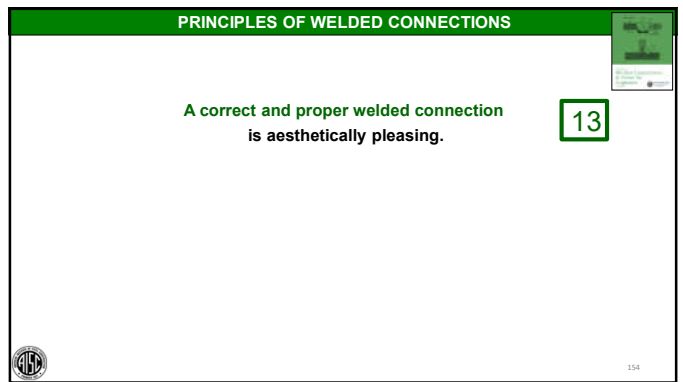
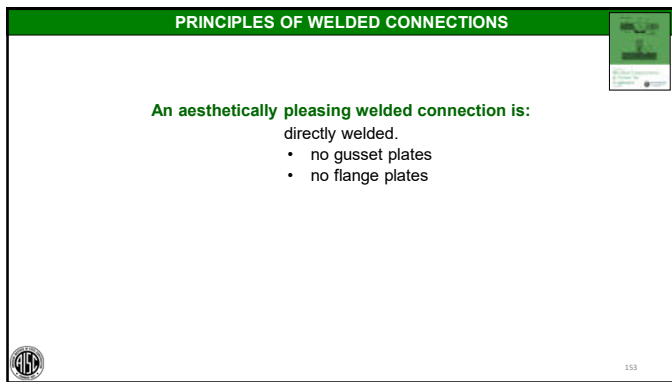
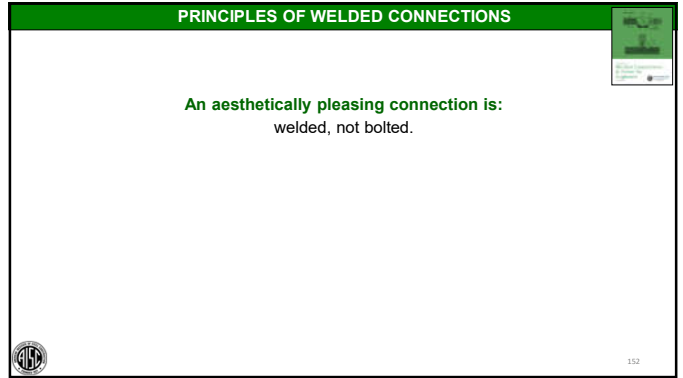
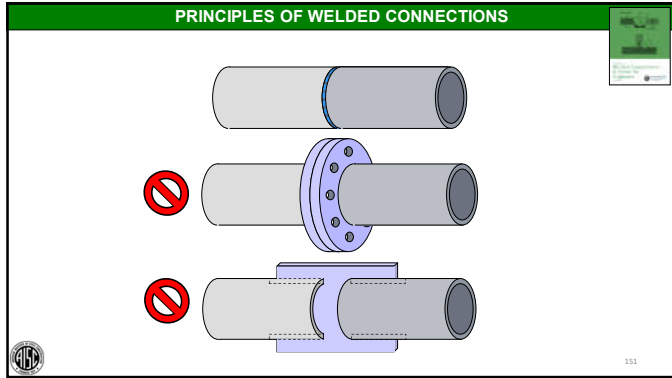

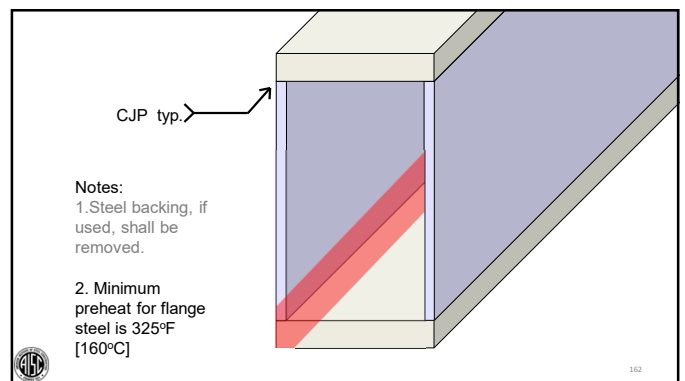
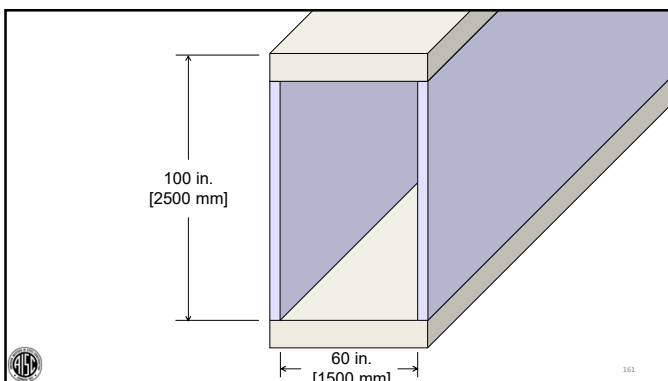
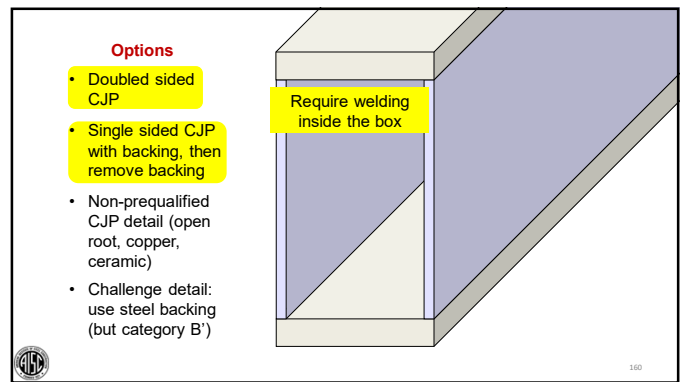
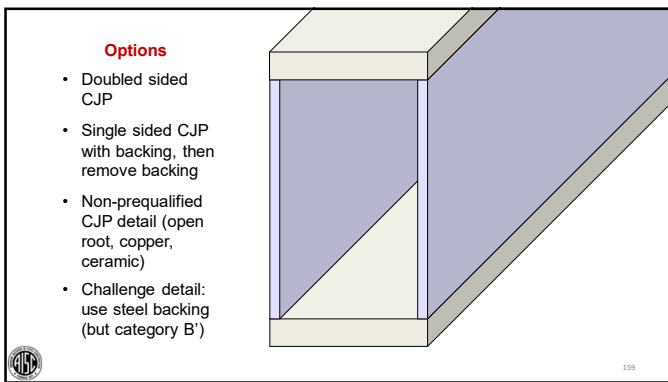
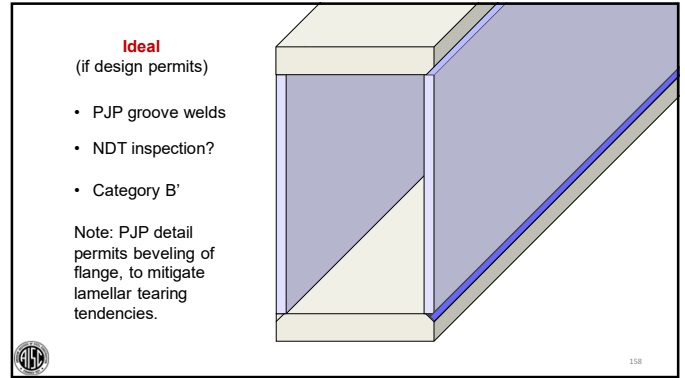
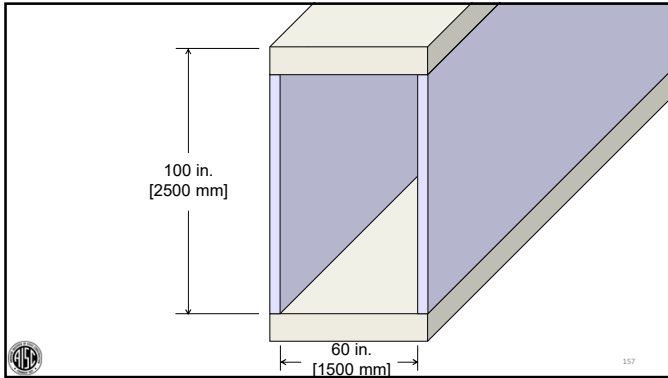

Options

- Doubled sided CJP
- Single sided CJP with backing, then remove backing
- Non-qualified CJP detail (open root, copper, ceramic)
- Challenge detail: use steel backing (but category B')

DENIED

163

Actual

- Doubled sided CJP
- Special safety precautions (heat, access, ventilation)
- Single bevel, gouge from outside
- No lamellar tearing, despite compromised detail

164

1. Bevel web plate
2. Assemble box

Note: root face permits accurate fitting

165

3. Preheat
4. Weld one side from inside box

Note: preheating done from outside box

166

5. Gouge from outside

167

6. Complete weld from outside

168

PRINCIPLES OF WELDED CONNECTIONS

A correct and proper welded connection can be made safely.

14



169

PRINCIPLES OF WELDED CONNECTIONS

14 Principles of Welded Connection Design

What makes a welded connection correct or proper?



170

Thank you!

AISC | Questions



Smarter.
Stronger.
Steel.

Individual Session Registrants

PDH Certificates

- All WFH individuals associated with a group registration will be issued a certificate.
- All individuals attending at your connection: you will receive an email on how to report their attendance from: registration@aisc.org.
 - Be on the lookout: Check your spam filter! Check your junk folder!
 - Completely fill out online form. Don't forget to check the boxes next to each attendee's name!



8-Session Registrants

PDH Certificates

One certificate will be issued at the conclusion of all 8 sessions.



8-Session Registrants

Access to the quiz

Information for accessing the quiz will be emailed to you by Wednesday. It will contain a link to access the quiz. EMAIL COMES FROM NIGHTSCHOOL@AISC.ORG.

Quiz and attendance records

Posted Friday mornings. www.aisc.org/nightschool -- Click on Current Course Details.

Reasons for quiz

- EEU – You must take all quizzes and the final exam to receive EEU.
- PDHs – If you watch a recorded session, you must pass quiz for PDHs.
- REINFORCEMENT – Reinforce what you learn tonight. Get more out of the course.

Note: If you attend the live presentation, you do not have to take the quizzes to receive PDHs



8-Session Registrants

Access to the recording

Information for accessing the recording will be emailed to you by Wednesday. The recording will be available for four weeks. (For 8-session registrants only.) EMAIL COMES FROM NIGHTSCHOOL@AISC.ORG.

PDHs via recording

If you watch a recorded session, you must take *and pass* the quiz for PDHs.



8-Session Registrants

Night School Resources

Find all your handouts, quizzes and quiz scores, recording access, and attendance information all in one place!



8-Session Registrants

Night School Resources

Go to www.aisc.org and sign in.

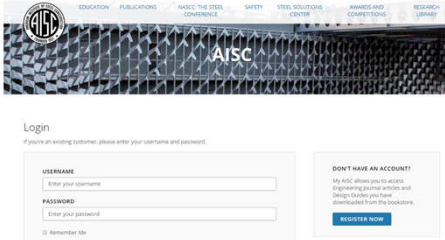

The screenshot shows the AISC website with navigation tabs for Education, Publications, NASSCO, The Steel Conference, Safety, Steel Solutions Center, Awards and Competitions, and Research Library. Below the navigation is a login form with fields for Username and Password, and a 'REGISTER NOW' button. A 'DON'T HAVE AN ACCOUNT?' link is also visible.

8-Session Registrants

Night School Resources

Go to www.aisc.org and sign in.

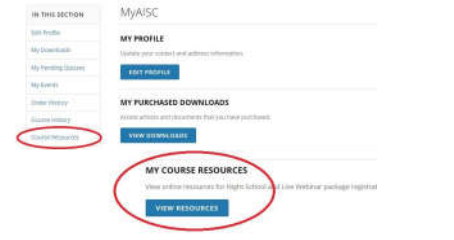

The screenshot shows the MyAISC user profile page. The 'MY PURCHASED DOWNLOADS' section has a 'VIEW PURCHASED' button circled in red. The 'MY COURSE RESOURCES' section has a 'VIEW RESOURCES' button circled in red.

8-Session Registrants

Night School Resources

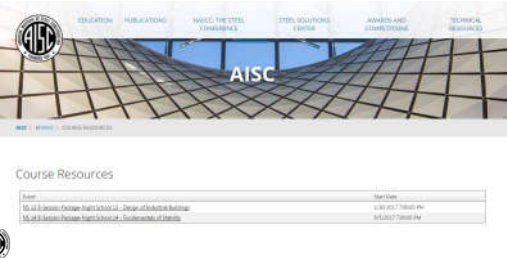

The screenshot shows the 'Course Resources' section of the AISC website. It features a table with columns for Name, Date, Method, View, and Attendance. The table lists various courses, including 'Design of Steel Structures' and 'Fundamentals of Welding'.

8-Session Registrants

Night School Resources

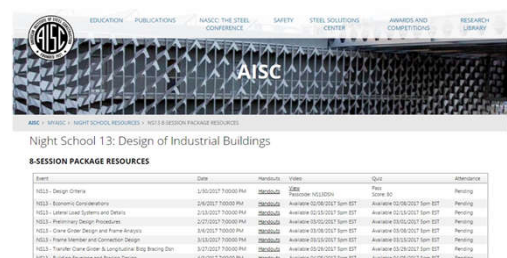

The screenshot shows the '8-SESSION PACKAGE RESOURCES' section of the AISC website. It features a table with columns for Event, Date, Method, View, and Attendance. The table lists various courses, including 'Design of Steel Structures' and 'Fundamentals of Welding'.

Event	Date	Method	View	Attendance
NEL-1 Design of Steel Structures	1/16/2021 7:00:00 AM	Webinar	View	None
NEL-2 Steel Design of Buildings and Bridges	2/16/2021 7:00:00 AM	Webinar	View	None
NEL-3 Fundamentals of Welding and Bolting	3/16/2021 7:00:00 AM	Webinar	View	None
NEL-4 Steel Deck Design and Frame Analysis	4/16/2021 7:00:00 AM	Webinar	View	None
NEL-5 Frame Member and Connection Design	5/16/2021 7:00:00 AM	Webinar	View	None
NEL-6 Steel Deck Design and Composite Floor Slab Design	6/16/2021 7:00:00 AM	Webinar	View	None
NEL-7 Steel Deck Design and Composite Floor Slab Design	7/16/2021 7:00:00 AM	Webinar	View	None
NEL-8 Steel Deck Design and Composite Floor Slab Design	8/16/2021 7:00:00 AM	Webinar	View	None

8-Session Registrants

Night School Resources

- Weekly “quiz and recording” email.
- Weekly updates of the master quiz and attendance record, found at www.aisc.org/nightschool27. Scroll down to Quiz and Attendance records.
 - Updated on Friday mornings.



8-Session Registrants

Night School Resources

- Webinar connection information
 - Reminder email sent out Monday mornings
- Links to handouts also found here



AISC | Thank you

