



Thank you for joining our live webinar. We will begin shortly. Please standby.

Vertical Bracing Connections, Session 1: Basic Principles
April 5, 2022 | William A Thornton



**Smarter.
Stronger.
Steel.**



Vertical Bracing Connections, Session 1: Basic Principles
April 5, 2022 | William A Thornton



Today's live webinar will begin shortly. Please stand by.

Today's audio will be broadcast through the internet. Please be sure to turn up the volume on your speakers.

Please type any questions or comments in the Q&A window.



AIA Credit

AISC is a Registered Provider with The American Institute of Architects Continuing Education Systems (AIA/CES). Credit(s) earned on completion of this program will be reported to AIA/CES for AIA members. Certificates of Completion for both AIA members and non-AIA members are available upon request.

This program has been submitted for AIA/CES for continuing professional education. As such, it does not include content that may be deemed or construed to be an approval or endorsement by the AIA of any material of construction or any method or manner of handling, using, distributing, or dealing in any material or product.

Questions related to specific materials, methods, and services will be addressed at the conclusion of this presentation.



Copyright Materials

This presentation is protected by US and International Copyright laws. Reproduction, distribution, display and use of the presentation without written permission of AISC is prohibited.

© The American Institute of Steel Construction 2022

The information presented herein is based on recognized engineering principles and is for general information only. While it is believed to be accurate, this information should not be applied to any specific application without competent professional examination and verification by a licensed professional engineer. Anyone making use of this information assumes all liability arising from such use.



Course Description

Vertical Bracing Connections

Basic Principles April 5, 2022

This session will introduce the course, discuss the limit states related to connection design as well as explore the methods of specifying connections as described in the AISC Code of Standard Practice. The session will then discuss that connection design is based on first principles, without the aid of complex computer models and with little codification. It will address the three basic principles of structural mechanics: equilibrium, constitutive equations (limit states), and compatibility. The presentation will then focus on the Lower Bound Theorem and look at it from a practical approach: satisfying equilibrium, not exceeding any limit states, and taking measures to ensure ductility. A simplified example demonstrating the concepts of the Lower Bound Theorem will be presented.



Learning Objectives

1. List the limit states of connection design and where they can be found in the AISC Specification.
2. List the three methods of specifying connections described in the AISC Code of Standard Practice.
3. Describe the basic principles of structural mechanics: equilibrium, constitutive equations and compatibility.
4. Explain the Lower Bound Theorem as it pertains to connection design.

Night School 28: Vertical Bracing Connections

Session 1: Introduction and Basic Principles April 5, 2022

William A. Thornton, corporate consultant to Cives Steel



Smarter.
Stronger.
Steel.

Vertical Bracing Connections

By: William Thornton, Rafael Sabelli, and Carol Drucker



Course Outline

1. Basic Principles
2. Uniform Force Method Part 1
3. Bracing Connection Details and Prying Action
4. Vertical Bracing Corner Connection – Wind and Low-seismic
5. Uniform Force Method Part 2
6. Vertical Bracing Corner Connection – Seismic
7. Chevron Gussets Connection
8. Other Connection Topics and Case Study



10

Course Outline

1. **Basic Principles**
2. Uniform Force Method Part 1
3. Bracing Connection Details and Prying Action
4. Vertical Bracing Corner Connection – Wind and Low-seismic
5. Uniform Force Method Part 2
6. Vertical Bracing Corner Connection – Seismic
7. Chevron Gussets Connection
8. Other Connection Topics and Case Study



11

Session Outline

1. Introduction
2. Limit States - the Specification, Manual, and Other Documents
3. Code of Standard Practice
4. Principles of structural mechanics
5. Lower Bound Theorem
6. Comparison of methods



12

Introduction to Course



13

Introduction to Course

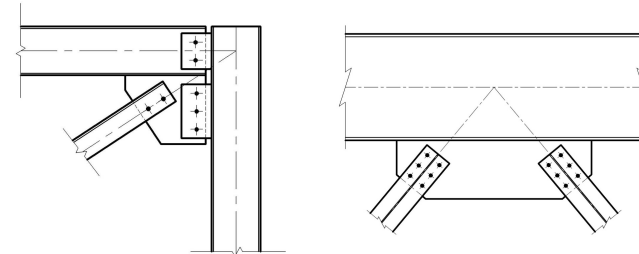

Corner

Chevron



14

Introduction to Course

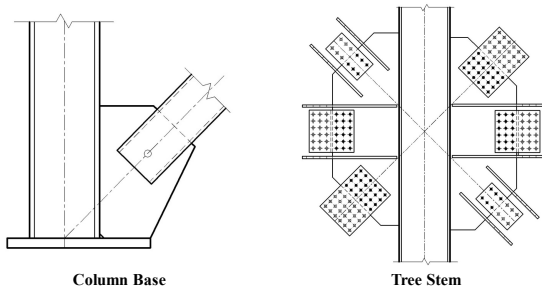

Column Base

Tree Stem



15

Session Outline

1. Introduction to connection design
2. Limit States - the Spec., Manual, and Other Documents
3. Lower Bound Theorem



16

Limit States - the *Specification*, *Manual*, and Other Documents



17

Connection Limit States

- In this section we will briefly discuss common connection limit states and where they can be found in the *AISC Specification*.
- The organization of the *Steel Construction Manual* as it relates to connection design will be reviewed.
- Finally, since not everything can be contained in these two documents, other useful resources are also presented.



18

Connection Limit States

The Limit States Governing Connection Design are found in:

1. Chapter B: Local Buckling
2. Chapter D: Net Tension/Shear Lag
3. Chapter J: Connections
4. Chapter K: HSS Members
5. Appendix 3: Fatigue
6. AISC Seismic Documents



19

Chapter D

D3 – Effective Net Area
Net Area
Effective Net Area (Table D3.1)

D4 – Built-up Members

D5 – Pin-Connected Members



20

Chapter J

- J1 – General Provisions**
- J2 – Welds**
- J3 – Bolts and Threaded Parts**
- J4 – Affected Elements of Members and Connecting Elements**
- J5 – Fillers**
- J6 – Splices



21

Chapter J (cont.)

- J7 – Bearing Strength
- J8 – Column Bases and Bearing on Concrete
- J9 – Anchor Rods and Embedments
- J10 – Flanges and Webs with Concentrated Forces**



22

AISC Seismic Documents

- Seismic Connections required when using $R > 3$
- Information regarding Seismic Connections can be found in:
 - Seismic Provisions for Structural Steel Buildings (ANSI/AISC 341-16)
 - Prequalified Connections for Special and Intermediate Steel Moment Frames for Seismic Applications (ANSI/AISC 358-16)



23

Connection Limit States Connectors

- Weld Rupture (Section J2.4)
- Bolt
 - Shear (Section J3.6)
 - Tension (Section J3.6)
 - Slip (Section J3.8)
 - Combined Tension and Shear, Bearing (Section J3.7)
 - Combined Tension and Shear, SC (Section J3.9)



24

Connection Limit States Local Effects

- Bolt Bearing and Tearout Strength at Bolt Holes (Section J3.10)
- Block Shear Strength (Section J4.3)
- Flange Local Bending (Section J10.1)
- Web Local Yielding (Section J10.2)
- Web Local Crippling (Section J10.3)
- Web Sidesway Buckling (Section J10.4)
- Web Compression Buckling (Section J10.5)
- Web Panel-Zone Shear (Section J10.6)



25

Connection Limit States Connecting Elements

- Yielding
 - Tension (Section J4.1)
 - Shear (Section J4.2)
- Fracture
 - Net Tension (Section J4.1)
 - Net Shear (Section J4.2)
- Buckling (Section J4.4)



26

Connection Limit States Beyond the Specification

- Prying Action
 - Part 9 of the Manual
- Yield Line Analysis
 - Anand and Bertz, *EJ*, 2nd Quarter, 1981
 - Akbar Tamboli, *Handbook of Steel Connection Design and Details*
- Whitmore Section
 - Part 9 of the Manual
 - Thornton and Lini, *Steel Wise, MSC, July 2011*



27

The AISC Manual

- Part 7 – Design Considerations for Bolts
- Part 8 – Design Considerations for Welds
- Part 9 – Design of Connection Elements
 - Prying Action
 - Rotational Ductility
 - Copes
- Part 10 – Design of Simple Shear Connections
 - Constructability
 - Shear Connection Tables
 - Extended Gages
 - Skewed, Sloped and Canted Connections



28

The AISC Manual

- Part 11 – Design of Partially Restrained Moment Connections
- Part 12 – Design of Fully Restrained Moment Connections
 - Moment Splices
- **Part 13 – Design of Bracing Connections and Truss Connections**
 - **Uniform Force Method and Variations**
- Part 14 – Design of Beam Bearing Plates, Column Base Plates, Anchor Rods, and Column Splices
- Part 15 – Design of Hanger Connections, Bracket Plates, and Crane-Rail Connections



29

Other Sources of Information

- **Chapter M of the Specification – Fabrication and Erection**
 - Thermal Cutting
 - Welded Construction
 - Bolted Construction
 - Thermally Cut Holes
 - Use of Shims $\leq 1/4"$
 - Compression Joints



30

Other Sources of Information

- **Research Council on Structural Connections (RCSC)**
 - Specification for Structural Joints Using High-Strength Bolts (The Bolt Spec.).
 - Guide to Design Criteria for Bolted and Riveted Joints (The Bolt Guide).
 - The Education section of the RSCS website also contains some valuable information.

All documents can be downloaded for free at
www.boltcouncil.org



31

Other Sources of Information

- **American Welding Society (AWS)**
 - AWS D1.1/D1.1M:2015 Structural Welding Code – Steel
 - AWS D1.8/D1.8M:2016 Structural Welding Code – Seismic Supplement



32

Other Sources of Information

- **AISC Design Guides**
 - Base Plate and Anchor Rod Design (**DG1**)
 - Extended End-Plate Moment Connections Seismic and Wind Applications (**DG4**)
 - Partially Restrained Composite Connections (**DG8**)
 - Modification of Existing Steel Welded Moment Frame Connections for Seismic Resistance (**DG12**)
 - Wide-Flange Column Stiffening at Moment Connections (**DG13**)



33

Other Sources of Information

- **AISC Design Guides (cont.)**
 - Flush and Extended Multiple Row Moment End-Plate Connections (**DG16**)
 - High Strength Bolts – A Primer for Structural Engineers (**DG17**)
 - Welded Connections – A Primer for Engineers (**DG21**)

**AISC Design Guides can be downloaded
at www.aisc.org (free to members)**



34

Other Sources of Information

- Resources for Steel Design (Modern Steel Construction December 2005) – by the ASCE/SEI Committee on Design of Steel Building Structures and AISC's Steel Solutions Center
- AISC's Engineering Frequently Asked Questions (www.aisc.org)
- AISC's Steel Solutions Center (www.aisc.org)
- OSHA 1926 Subpart R – Steel Erection



35

Connection Design and the Code of Standard Practice



36

Connection Design and the COSP

3) For Option 3 (Connections by Fabricator):

A. Fabricator can select connection best suited for their shop. Examples:

- a. Shear tabs to double-angles
- b. Welded bracing to bolted bracing

B. Connection engineer shall review shop and erection drawings.



41

Connection Design and the COSP

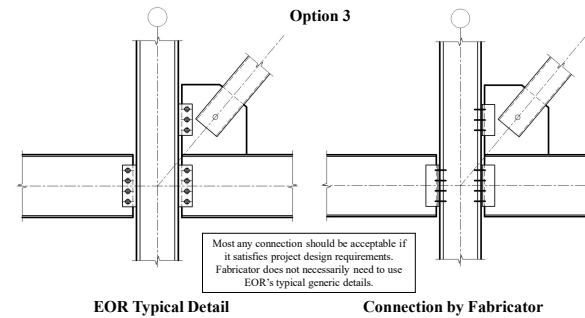

42

Basis of Connection Design



43

Basis of Connection Design

- Connection Design Tools and Methods
- Assumptions and Uncertainty
- Lower Bound Theorem
- Connection Design: Art and Science



44

Connection Design

Connection design has been called the

Last Bastion of Rational Design

Most connection design is accomplished

- based on first principles
- without the aid of complex computer models
- with little codification



45

Economy Through Connection Design

In no other important industry is the responsibility for design so far removed from the responsibility for production.

~Sir Harold Emerson
Minister of the Works
(1962)

It has been estimated that 50% of the cost of erected steel is related to the connection design.



46

Connection Design

Primary tools used by the connection designer

- Free body diagrams
- The Lower Bound Theorem
- Empirical Data (distilled into rational design procedures)
- Intuition based on experience



47

Analysis of Connections



48

We do not know the distribution of forces in the structures we design.



49

Assumptions routinely made during the analysis process:

- Isotropic
- Homogeneous
- Elastic
- Perfectly Plastic
- Pinned
- Fixed
- Laterally Supported
- Torsionally Restrained
- And Many, Many More



50



“Pinned” Truss Connections

51

A vertical brace connection is a highly indeterminate system

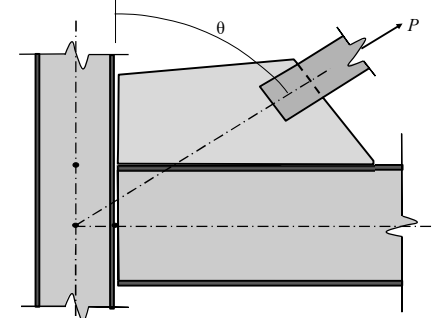

52

Uniform Force Method

$$r = \sqrt{(\alpha + e_c)^2 + (\beta + e_b)^2}$$

$$V_c = \frac{\beta}{r} P \quad H_c = \frac{e_c}{r} P$$

$$V_b = \frac{e_b}{r} P \quad H_b = \frac{\alpha}{r} P$$

These equations represent one of an infinite number of statically admissible force distributions.



In a specific connection the UFM produces the force distribution shown:

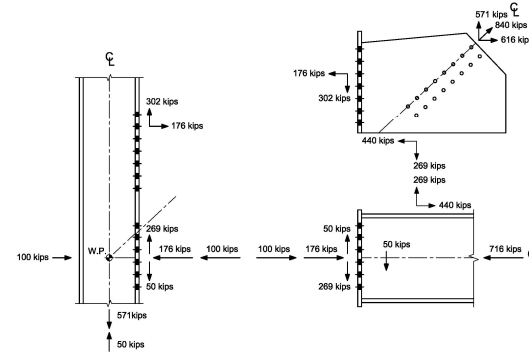

“Pinned” Truss Connections



In a specific connection the UFM produces the force distribution shown:

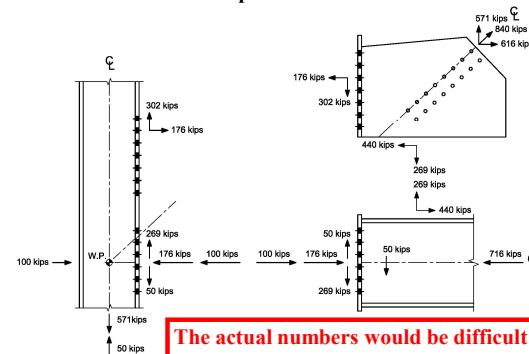

The actual numbers would be difficult to follow and are really immaterial at this point.



In a specific connection the UFM produces the force distribution shown:

However, there are several important items to note in the final force distribution.

Ref. AISC Design Guide 29: Vertical Bracing Connections
 Free Download for Members: aisc.org/dg

57

In a specific connection the UFM produces the force distribution shown:

No additional moments have been introduced to the column beyond the bounds of the connection.

Ref. AISC Design Guide 29: Vertical Bracing Connections
 Free Download for Members: aisc.org/dg

58

In a specific connection the UFM produces the force distribution shown:

No additional moments have been introduced to the beam beyond the bounds of the connection.

Ref. AISC Design Guide 29: Vertical Bracing Connections
 Free Download for Members: aisc.org/dg

59

In a specific connection the UFM produces the force distribution shown:

It is common practice to design the vertical bracing system as a pinned truss.

Ref. AISC Design Guide 29: Vertical Bracing Connections
 Free Download for Members: aisc.org/dg

60

In a specific connection the UFM produces the force distribution shown:

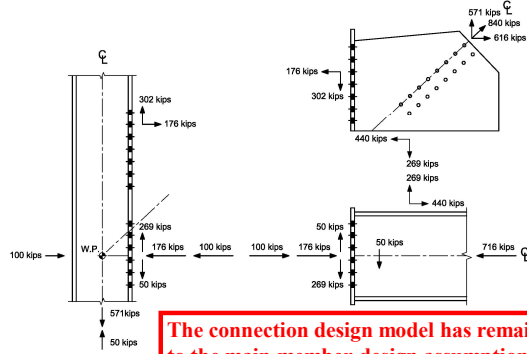

The connection design model has remained true to the main member design assumptions. This is a basic tenet of connection design.

Ref. AISC Design Guide 29: Vertical Bracing Connect. Free Download for Members: aisc.org/dg

Angle Gages

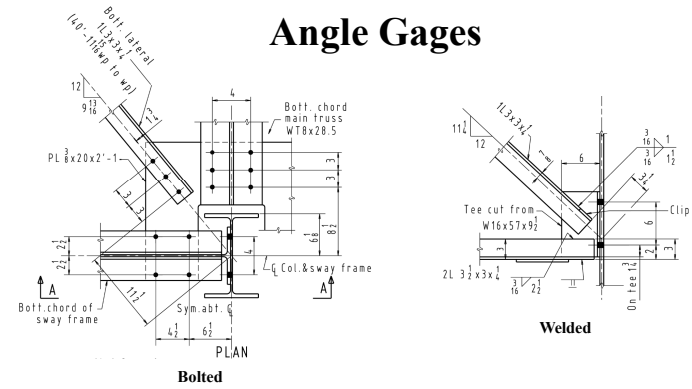

62

Angle Gages Bolted

Table 1-7A
 Workable Gages in Angle Legs, in.

Log	8	7	6	5	4	3 1/2	3	2 1/2	2	1 1/2	1 1/4	1 1/8	1
g ₁	4 1/2	4	3 1/2	3	2 1/2	2	1 3/4	1 1/2	1 1/4	1	7/8	3/4	5/8
g ₂	3	2 1/2	2 1/4	2	1 3/4	1 1/2	1 1/4	1 1/8	1	7/8	3/4	5/8	
g ₃	3	3	2 1/2	1 3/4									

Note: Other gages are permitted to suit specific requirements subject to clearances and edge distance limitations.

63

Question:
 But how do we know this is the force distribution in the connection?

64

**Answer:
We Don't**



65

**Answer:
We Don't
And it probably isn't.**



66

**Steel is smarter than the engineers who
design it.**

~~~~ **Jim Wooten**  
MSC 2<sup>nd</sup> Qtr 1971



67

## **Lower Bound Theorem**

The applied external forces in equilibrium with the internal force field are less than or, at most, equal to the applied external force that would cause failure, provided that all the limit states are satisfied and sufficient ductility exists to allow redistribution of the forces.

~~~~From Baker, Neal, etc.



68

Lower Bound Theorem A Practical Approach

1. Choose a force distribution that satisfies equilibrium.
2. Do not exceed any limit states.
3. Take reasonable measures to ensure ductility.



69

What Does This Mean?

- A designer has the freedom to choose any convenient force distribution if:
 - Equilibrium is satisfied
 - No limit states are exceeded
 - And loads can redistribute without fracture



70

Why?

- Force is attracted to stiffness.
- When a member yields it becomes less stiff and sheds loads to other elements.
- If there is somewhere for the load to go, it will go there.
- Steel is inherently ductile.



71

Change in Stiffness Related to Yielding

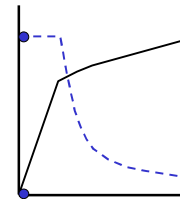

- The black line represents stress versus strain.
- The blue dashed line represents the modulus of elasticity, E , versus strain.
- As the material yields the effective E , and therefore the stiffness, decreases and the load redistributes.



72

Change in Stiffness Related to Yielding

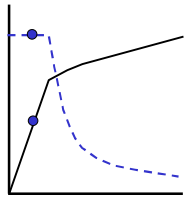

- The black line represents stress versus strain.
- The blue dashed line represents the modulus of elasticity, E , versus strain.
- As the material yields the effective E , and therefore the stiffness, decreases and the load redistributes.



73

Change in Stiffness Related to Yielding

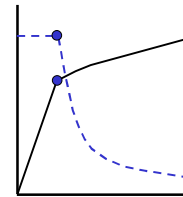

- The black line represents stress versus strain.
- The blue dashed line represents the modulus of elasticity, E , versus strain.
- As the material yields the effective E , and therefore the stiffness, decreases and the load redistributes.



74

Change in Stiffness Related to Yielding

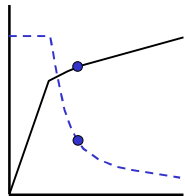

- The black line represents stress versus strain.
- The blue dashed line represents the modulus of elasticity, E , versus strain.
- As the material yields the effective E , and therefore the stiffness, decreases and the load redistributes.



75

Change in Stiffness Related to Yielding

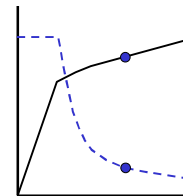

- The black line represents stress versus strain.
- The blue dashed line represents the modulus of elasticity, E , versus strain.
- As the material yields the effective E , and therefore the stiffness, decreases and the load redistributes.



76

Change in Stiffness Related to Yielding

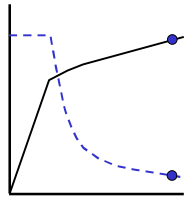

- The black line represents stress versus strain.
- The blue dashed line represents the modulus of elasticity, E , versus strain.
- As the material yields the effective E , and therefore the stiffness, decreases and the load redistributes.



77

Connections: Art and Science

- The ART of load paths - An intuitive knowledge of how a system will transmit loads.
- The SCIENCE of equilibrium and limit states - an understanding of structural mechanics.



78

**The art involves finding the load path
which maximizes the external load.**

~ ~ ~ **Bill Thornton**



79

Corollary to the Lower Bound Theorem

The admissible internal force field that maximizes the capacity is closest to the collapse solution.

Admissible is just another way of saying a system of forces that satisfies equilibrium.



80

An Example

As an example

- Assume a simple system of three identical tension members supporting a load.
- This is an indeterminate structure, though intuitively we know each bar supports an equal load.
- However if we assume the center bar supports a percentage of the load, x , and the results are plotted, we have a very simple example of the Lower Bound Theorem.

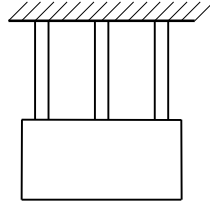

81

| X | P |
|------|-------|
| 0.00 | 66.67 |
| 0.10 | |
| 0.13 | |
| 0.25 | |
| 0.33 | |
| 0.50 | |
| 0.67 | |
| 0.75 | |
| 0.88 | |
| 1.00 | |

An Example

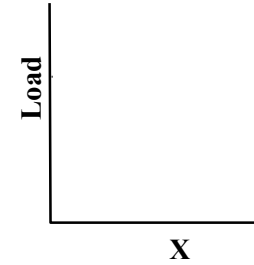

x = the % of total load supported by center member
 P = total load supported with assumed load distribution



82

| X | P |
|------|-------|
| 0.00 | 66.67 |
| 0.10 | 74.07 |
| 0.13 | 76.19 |
| 0.25 | |
| 0.33 | |
| 0.50 | |
| 0.67 | |
| 0.75 | |
| 0.88 | |
| 1.00 | |

An Example

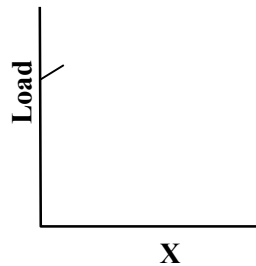

x = the % of total load supported by center member
 P = total load supported with assumed load distribution



83

| X | P |
|------|-------|
| 0.00 | 66.67 |
| 0.10 | 74.07 |
| 0.13 | 76.19 |
| 0.25 | 88.89 |
| 0.33 | |
| 0.50 | |
| 0.67 | |
| 0.75 | |
| 0.88 | |
| 1.00 | |

An Example

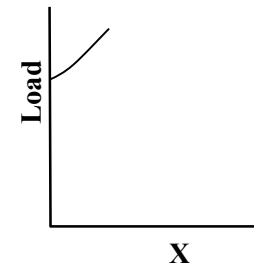

x = the % of total load supported by center member
 P = total load supported with assumed load distribution



84

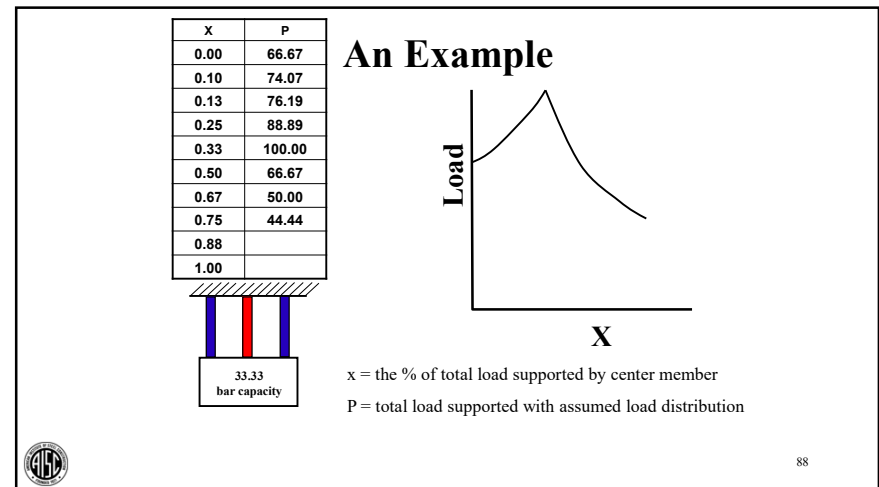
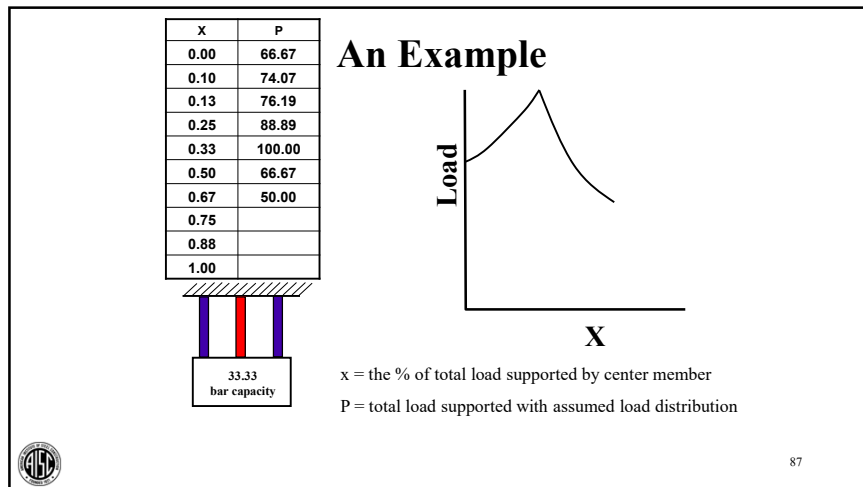
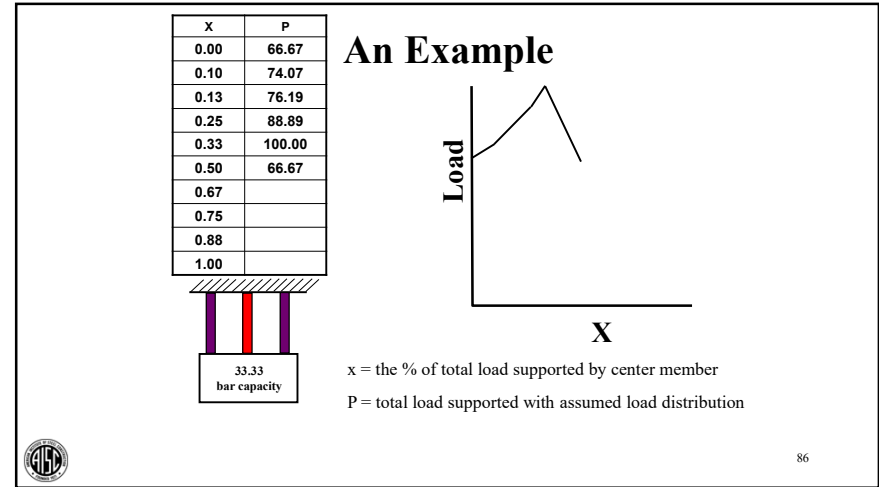
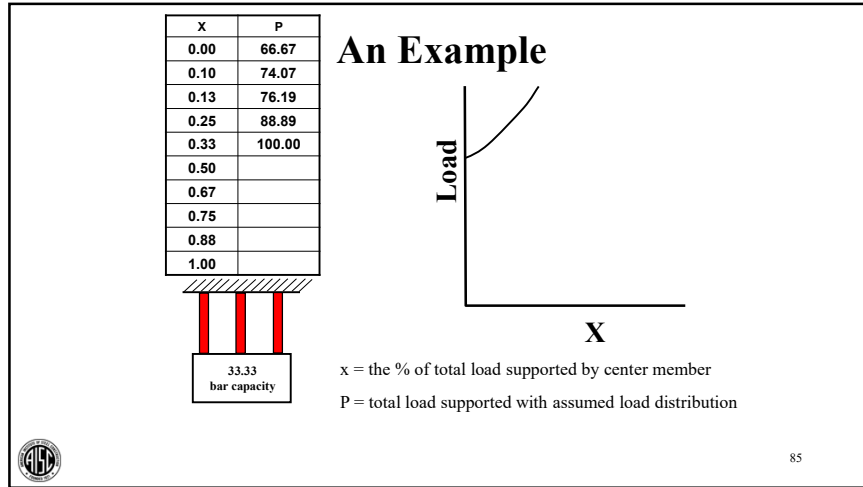

An Example

| X | P |
|------|--------|
| 0.00 | 66.67 |
| 0.10 | 74.07 |
| 0.13 | 76.19 |
| 0.25 | 88.89 |
| 0.33 | 100.00 |
| 0.50 | 66.67 |
| 0.67 | 50.00 |
| 0.75 | 44.44 |
| 0.88 | 38.10 |
| 1.00 | 33.33 |

x = the % of total load supported by center member
 P = total load supported with assumed load distribution

89

Lower Bound Solution Three Bar Structure

Equilibrium: $2F + xP - P = 0$
 Limit States: $F \leq 33.3$
 $xP \leq 33.3$
 $P \leq 100$

$x = \% \text{ of Total Load } P$

90

Lower Bound Solution Three Bar Structure

Example: Let $x = 0.5$

$0.5P \leq 33.3 \rightarrow P = 66.7 < 100$ OK
 $0.25P \leq 33.3 \rightarrow P = 133 > 100$ NG
Solution: $P = 66.7$

91

More Information on Ductility and Behavior of Steel

Basic Concepts in Ductile Detailing of Steel Structures
 by Michael D. Engelhardt – aisc.org/educationarchives

Ductility: Another View by Duane K. Miller – Upcoming AISC
 Webinar, April 12 – aisc.org/webinars

92

Comparison of Bracing Design Methods and Load Paths



93

Comparison of Methods

The next several slides will demonstrate the savings that can be obtained through a careful use of the topics discussed in this presentation.

A special emphasis is placed on load paths, but all the other considerations have also been accounted for in these optimal designs.



94

Load Paths Have Consequences

In Other Words...



95

Let's Look at the Bottom Line



96

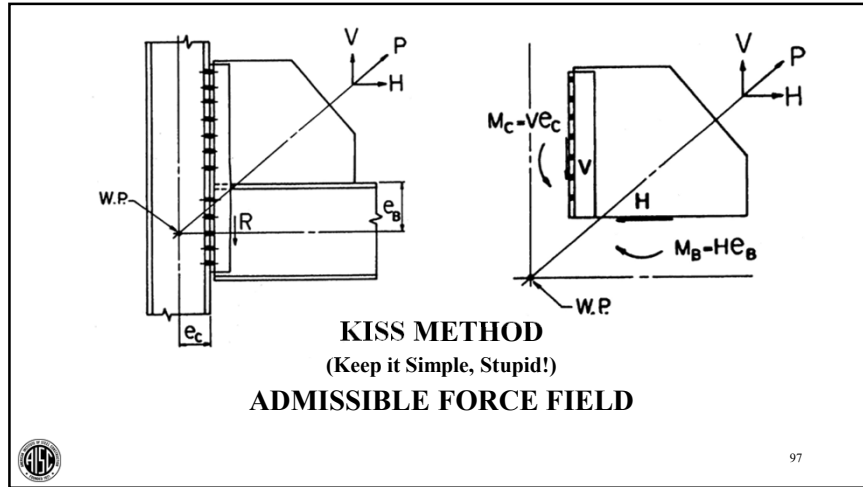

- ### The KISS method
- Was used with and without the couples M_B and M_C , but mostly without
 - Was used with the brace vertical component on the column connection and the brace horizontal component on the beam connection
 - Was used without regard to the Work Point position
 - INADMISSIBLE FORCE FIELDS

The KISS method

An inadmissible force field does not satisfy what William McGuire of Cornell, in another context, called “The niceties of Structural Mechanics”

McGuire, Steel Structures, Prentice- Hall, 1968, page 933

The KISS method

In particular, the
**LOWER BOUND THEOREM IS
 INVALID**
 If an inadmissible force field is
 used

Kiss Method VS Uniform Force Method

Is there an economic reason to use KISS?
 It **is** simpler, even with the couples



101

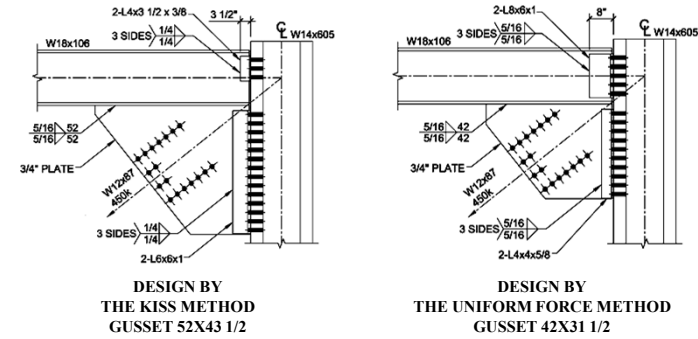

COMPARISON OF DESIGNS



102

| | |
|--------------|-----------------------------|
| KISS = | \$840 PER CONNECTION |
| UNIFORM = | <u>\$658</u> PER CONNECTION |
| DIFFERENCE = | \$182 PER CONNECTION |

40 STORY BUILDING WITH 32 CONNECTIONS PER FLOOR

EQUALS

\$240,000 SAVED

Taken From: Bill Thornton's "Last Bastion of Rational Design"



103

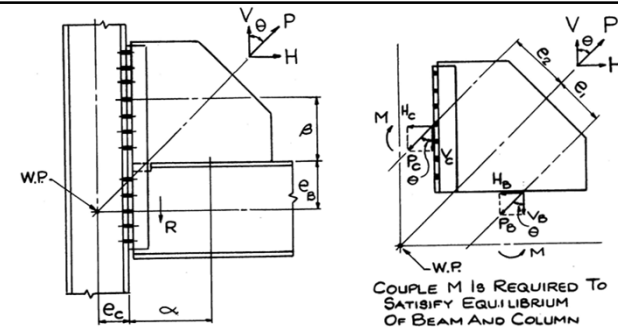

**PARALLEL FORCE METHOD (PFM)
 ADMISSIBLE FORCE FIELD**



104

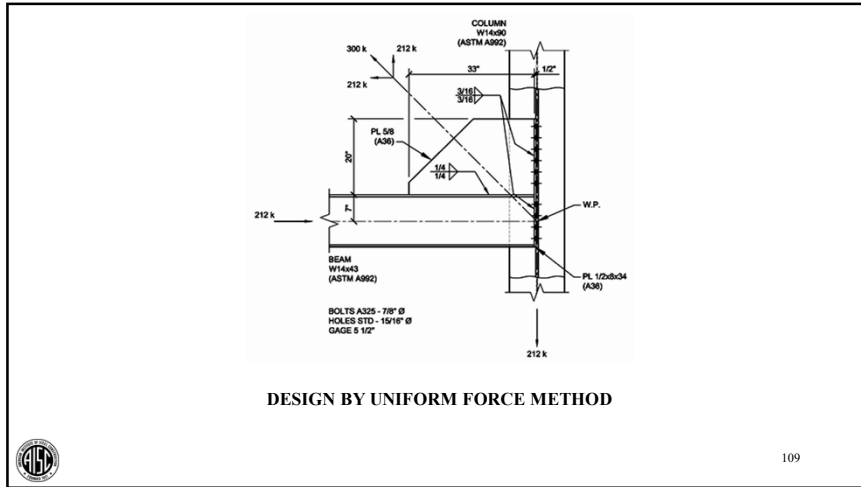

**LOAD PATHS HAVE
CONSEQUENCES**

**UFM Design with UFM admissible
force field**

Capacity is 320 kips

**LOAD PATHS HAVE
CONSEQUENCES**

**UFM Design with KISS admissible
force field**

Capacity is 236 kips

**LOAD PATHS HAVE
CONSEQUENCES**

**UFM Design with PFM admissible
force field**

Capacity is 86 kips

LOAD PATHS HAVE CONSEQUENCES

| METHOD | DESIGN | DESIGN STRENGTH |
|--------|--------|-----------------|
| UFM | UFM | 320 kips |
| KISS | UFM | 236 kips |
| PFM | UFM | 86 kips |

These results are for the design achieved by the UFM.



113



A \$2 Million dollar savings compared to the original estimate was attributed to the connection design on these two projects.



114



Conventional and Extended Tabs replaced the more traditional double clips at the jumbo columns reducing both fabrication and erection costs.

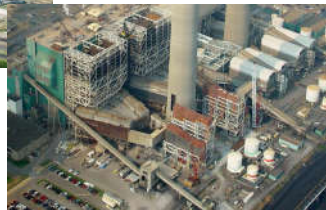

115



The Uniform Force Method was used extensively in novel ways to optimize the connections.



116

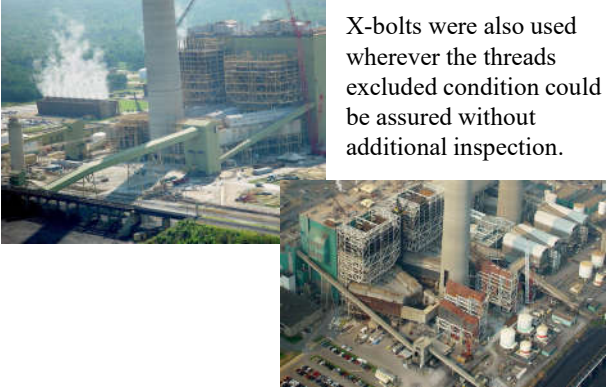

X-bolts were also used wherever the threads excluded condition could be assured without additional inspection.



117

Bolts: $\frac{3}{4}$ " ϕ A325 in std. holes

W16x26
R=20 kips

W14x145

2'-0"

HSS10x10x5/16
P=150 kips

35"

$\frac{1}{2}$ " Tab Pl.

$\frac{3}{4}$ " Stiff. Pl for strong axis moment conn.

Vertical Bracing w/ Ext. Tab Optimum Load Path --
 Special Case IV



118

Bolts: 1" ϕ A490 in std. holes

W16x26
R=20 kips

W14x145

2'-0"

HSS10x10x5/16
P=150 kips

35"

1" Tab Pl.

$\frac{3}{4}$ " Stiff. Pl for strong axis moment conn.

Vertical Bracing w/ Ext. Tab Standard Load Path --
 Ordinary Uniform Force Method (UFM)



119

$\frac{1}{2}$ " Tab Pl.

Special Case IV

1/2" PLATE (A36)

1" PLATE (Gr50)

1" Tab Pl.

Ordinary UFM



120

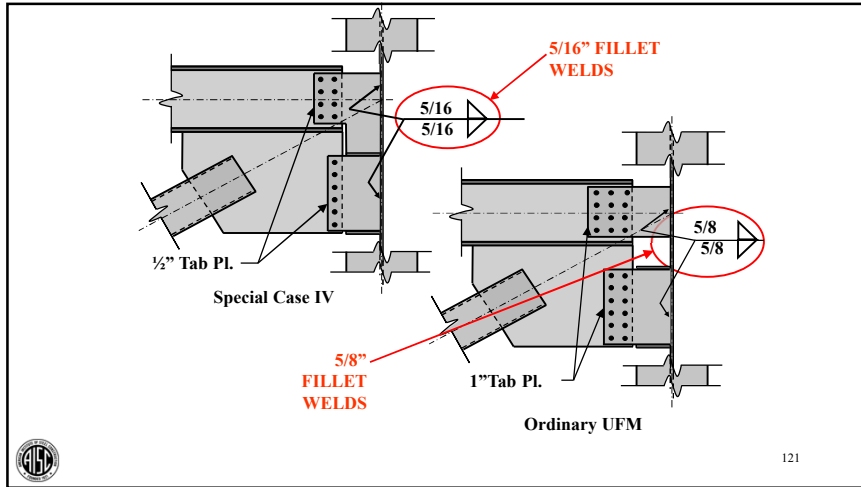

121

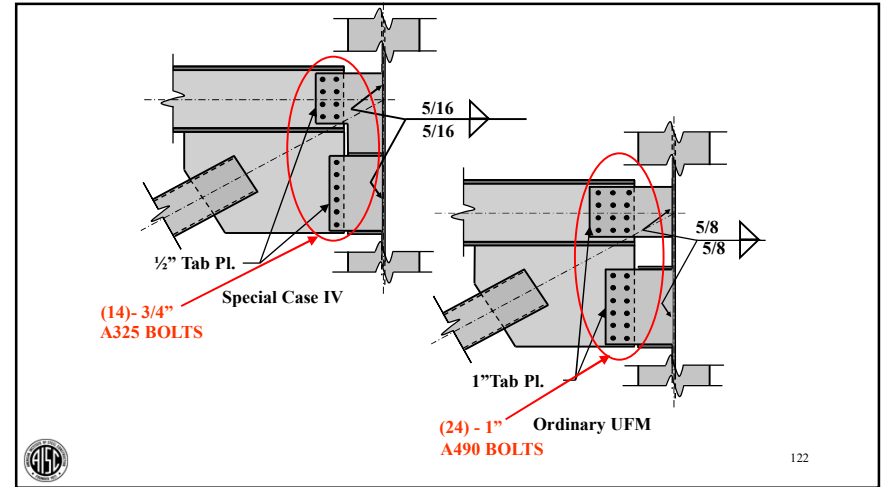

122

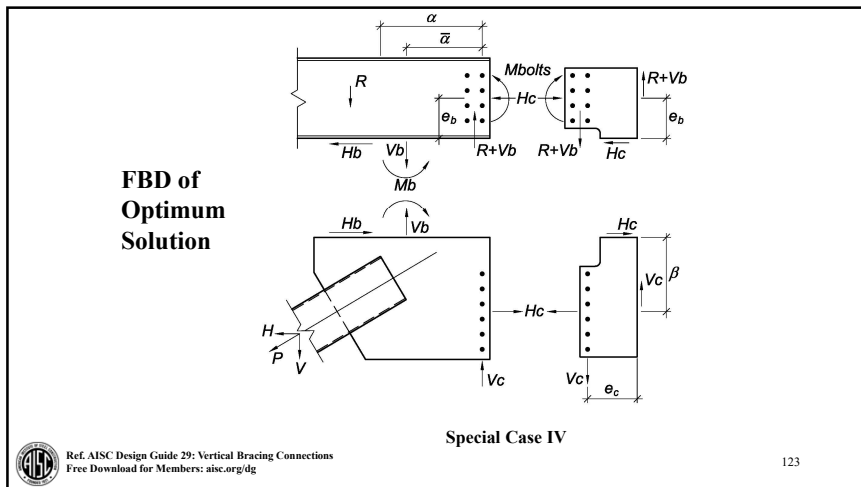

123

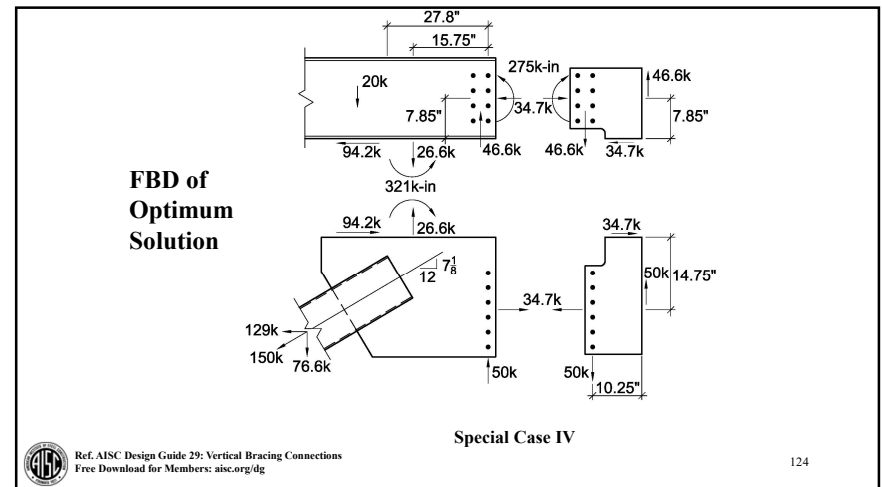

124

Comparison of Design Results

| | COMPARISON OF DESIGNS RESULTING FROM DIFFERENT LOAD PATHS | | | | | | | | | | | | | | |
|--------------------|---|--------------------|--------------------------------|-----------------------------------|-----------------|--------------|----------------------------|-------------------------------|----------------------------------|-------------------|---------------------------------|------------------------------------|---------------------|-----------------------------------|---------------------------------|
| | DRILLING | | | | WELDING | | | | MATERIAL | | | | | | |
| | # of Holes | Plate Thick. (in.) | Area Holes (in. ²) | Vol. of Holes (in. ³) | Weld Size (in.) | Length (in.) | Volume (in. ³) | Length Single Pass Weld (in.) | Area of Tabs (in. ²) | Thick. Tabs (in.) | Volume Tabs (in. ³) | Area of Gusset (in. ²) | Thick. Gusset (in.) | Volume Gusset (in. ³) | Weight Connection Plates (lbs.) |
| Standard Load Path | 24 | 1 | 0.6 | 14.4 | 5/8 | 30.0 | 5.86 | 180 | 3.25 | 0.083 | 0.27 | 5.41 | 0.417 | 0.226 | 243 |
| Optimum Load Path | 14 | 0.5 | 0.44 | 3.09 | 5/16 | 52.3 | 2.55 | 52.3 | 3.00 | 0.042 | 0.12 | 5.41 | 0.417 | 0.226 | 172 |
| Optimum Standard | | | | 21% | | | 44% | 29% | | | | | | | 71% |

Note:
 Standard Load Path = Ordinary UFM
 Optimum Load Path = Special Case IV



125

Comparison of Design Results

| | COMPARISON OF DESIGNS RESULTING FROM DIFFERENT LOAD PATHS | | | | | | | | | | | | | | |
|--------------------|---|--------------------|--------------------------------|-----------------------------------|-----------------|--------------|----------------------------|-------------------------------|----------------------------------|-------------------|---------------------------------|------------------------------------|---------------------|-----------------------------------|---------------------------------|
| | DRILLING | | | | WELDING | | | | MATERIAL | | | | | | |
| | # of Holes | Plate Thick. (in.) | Area Holes (in. ²) | Vol. of Holes (in. ³) | Weld Size (in.) | Length (in.) | Volume (in. ³) | Length Single Pass Weld (in.) | Area of Tabs (in. ²) | Thick. Tabs (in.) | Volume Tabs (in. ³) | Area of Gusset (in. ²) | Thick. Gusset (in.) | Volume Gusset (in. ³) | Weight Connection Plates (lbs.) |
| Standard Load Path | 24 | 1 | 0.6 | 14.4 | 5/8 | 30.0 | 5.86 | 180 | 3.25 | 0.083 | 0.27 | 5.41 | 0.417 | 0.226 | 243 |
| Optimum Load Path | 14 | 0.5 | 0.44 | 3.09 | 5/16 | 52.3 | 2.55 | 52.3 | 3.00 | 0.042 | 0.12 | 5.41 | 0.417 | 0.226 | 172 |
| Optimum Standard | | | | 21% | | | 44% | 29% | | | | | | | 71% |

Note:
 Standard Load Path = Ordinary UFM
 Optimum Load Path = Special Case IV

± 80% SAVINGS IN
 DRILLING TIME



126

Comparison of Design Results

| | COMPARISON OF DESIGNS RESULTING FROM DIFFERENT LOAD PATHS | | | | | | | | | | | | | | |
|--------------------|---|--------------------|--------------------------------|-----------------------------------|-----------------|--------------|----------------------------|-------------------------------|----------------------------------|-------------------|---------------------------------|------------------------------------|---------------------|-----------------------------------|---------------------------------|
| | DRILLING | | | | WELDING | | | | MATERIAL | | | | | | |
| | # of Holes | Plate Thick. (in.) | Area Holes (in. ²) | Vol. of Holes (in. ³) | Weld Size (in.) | Length (in.) | Volume (in. ³) | Length Single Pass Weld (in.) | Area of Tabs (in. ²) | Thick. Tabs (in.) | Volume Tabs (in. ³) | Area of Gusset (in. ²) | Thick. Gusset (in.) | Volume Gusset (in. ³) | Weight Connection Plates (lbs.) |
| Standard Load Path | 24 | 1 | 0.6 | 14.4 | 5/8 | 30.0 | 5.86 | 180 | 3.25 | 0.083 | 0.27 | 5.41 | 0.417 | 0.226 | 243 |
| Optimum Load Path | 14 | 0.5 | 0.44 | 3.09 | 5/16 | 52.3 | 2.55 | 52.3 | 3.00 | 0.042 | 0.12 | 5.41 | 0.417 | 0.226 | 172 |
| Optimum Standard | | | | 21% | | | 44% | 29% | | | | | | | 71% |

Note:
 Standard Load Path = Ordinary UFM
 Optimum Load Path = Special Case IV

± 50% SAVINGS IN
 WELD CONSUMABLES



127

Comparison of Design Results

| | COMPARISON OF DESIGNS RESULTING FROM DIFFERENT LOAD PATHS | | | | | | | | | | | | | | |
|--------------------|---|--------------------|--------------------------------|-----------------------------------|-----------------|--------------|----------------------------|-------------------------------|----------------------------------|-------------------|---------------------------------|------------------------------------|---------------------|-----------------------------------|---------------------------------|
| | DRILLING | | | | WELDING | | | | MATERIAL | | | | | | |
| | # of Holes | Plate Thick. (in.) | Area Holes (in. ²) | Vol. of Holes (in. ³) | Weld Size (in.) | Length (in.) | Volume (in. ³) | Length Single Pass Weld (in.) | Area of Tabs (in. ²) | Thick. Tabs (in.) | Volume Tabs (in. ³) | Area of Gusset (in. ²) | Thick. Gusset (in.) | Volume Gusset (in. ³) | Weight Connection Plates (lbs.) |
| Standard Load Path | 24 | 1 | 0.6 | 14.4 | 5/8 | 30.0 | 5.86 | 180 | 3.25 | 0.083 | 0.27 | 5.41 | 0.417 | 0.226 | 243 |
| Optimum Load Path | 14 | 0.5 | 0.44 | 3.09 | 5/16 | 52.3 | 2.55 | 52.3 | 3.00 | 0.042 | 0.12 | 5.41 | 0.417 | 0.226 | 172 |
| Optimum Standard | | | | 21% | | | 44% | 29% | | | | | | | 71% |

Note:
 Standard Load Path = Ordinary UFM
 Optimum Load Path = Special Case IV

± 60% SAVINGS IN
 WELDING LABOR



128

Comparison of Design Results

| | DRILLING | | | | WELDING | | | | MATERIAL | | | | | | |
|--------------------|------------|--------------------|--------------------------------|-----------------------------------|-----------------|--------------|----------------------------|-------------------------------|----------------------------------|-------------------|---------------------------------|------------------------------------|---------------------|-----------------------------------|---------------------------------|
| | # of Holes | Plate Thick. (in.) | Area Holes (in. ²) | Vol. of Holes (in. ³) | Weld Size (in.) | Length (in.) | Volume (in. ³) | Length Single Pass Weld (in.) | Area of Tabs (in. ²) | Thick. Tabs (in.) | Volume Tabs (in. ³) | Area of Gusset (in. ²) | Thick. Gusset (in.) | Volume Gusset (in. ³) | Weight Connection Plates (lbs.) |
| Standard Load Path | 24 | 1 | 0.6 | 14.4 | 5/8 | 30.0 | 5.86 | 180 | 3.25 | 0.083 | 0.27 | 5.41 | 0.417 | 0.226 | 243 |
| Optimum Load Path | 14 | 0.5 | 0.44 | 3.09 | 5/16 | 52.3 | 2.55 | 52.3 | 3.00 | 0.042 | 0.12 | 5.41 | 0.417 | 0.226 | 172 |
| Optimum Standard | | | 21% | | | 44% | 29% | | | | | | | | 71% |

Note:
Standard Load Path = Ordinary UFM
Optimum Load Path = Special Case IV

± 30% SAVINGS IN MATERIAL



Summary

In this presentation we have reviewed the basic principles of structural mechanics and bracing design.

We have shown the design achieved depends on the load path (admissible force field) assumed.

We have shown the importance of the Lower Bound Theorem for design

Next Week- UFM in Detail

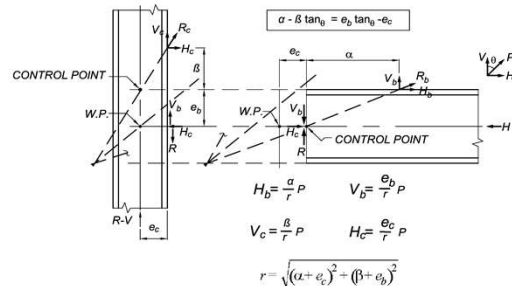

Vertical Bracing Connections, Session 1: Basic Principles
April 5, 2022 | William A Thornton



Thank you!

AISC | Questions



Individual Session Registrants

PDH Certificates

- All WFH individuals associated with a group registration will be issued a certificate.
- All individuals attending at your connection: you will receive an email on how to report their attendance from: registration@aisc.org.
 - Be on the lookout: Check your spam filter! Check your junk folder!
 - Completely fill out online form. Don't forget to check the boxes next to each attendee's name!



8-Session Registrants

PDH Certificates

One certificate will be issued at the conclusion of all 8 sessions.



8-Session Registrants

Access to the quiz

Information for accessing the quiz will be emailed to you by Wednesday. It will contain a link to access the quiz. EMAIL COMES FROM NIGHTSCHOOL@AISC.ORG.

Quiz and attendance records

Posted Friday mornings. www.aisc.org/nightschool – Click on Current Course Details.

Reasons for quiz

- EEU – You must take all quizzes and the final exam to receive EEU.
- PDHs – If you watch a recorded session, you must pass quiz for PDHs.
- REINFORCEMENT – Reinforce what you learn tonight. Get more out of the course.

Note: If you attend the live presentation, you do not have to take the quizzes to receive PDHs



8-Session Registrants

Access to the recording

Information for accessing the recording will be emailed to you by Wednesday. The recording will be available for four weeks. (For 8-session registrants only.) EMAIL COMES FROM NIGHTSCHOOL@AISC.ORG.

PDHs via recording

If you watch a recorded session, you must take *and pass* the quiz for PDHs.



8-Session Registrants

Night School Resources

Find all your handouts, quizzes and quiz scores, recording access, and attendance information all in one place!



8-Session Registrants

Night School Resources

Go to www.aisc.org and sign in.



Login

If you're an existing customer, please enter your username and password.

USERNAME

Enter your username

PASSWORD

Enter your password

Remember Me

DON'T HAVE AN ACCOUNT?

My AISC allows you to access Engineering Journal articles and Design Guides you have downloaded from the bookstore.

[REGISTER NOW](#)

8-Session Registrants

Night School Resources

Go to www.aisc.org and sign in.

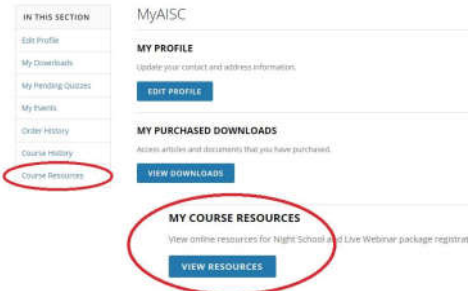

8-Session Registrants

Night School Resources



Course Resources

| Event | Start Date |
|--|----------------------|
| NS 13 8-Session Package Night School 13 - Design of Industrial Buildings | 8/19/2017 7:00:00 PM |
| NS 14 8-Session Package Night School 14 - Fundamentals of Seismic | 9/5/2017 7:00:00 PM |



8-Session Registrants

Night School Resources



Night School 13: Design of Industrial Buildings

8-SESSION PACKAGE RESOURCES

| Event | Date | Handouts | Notes | Quiz | Attendance |
|--|----------------------|--------------------------|------------------------------|------------------------------|------------|
| NS13 - Design Criteria | 1/30/2017 7:00:00 PM | Download | PDF
P13000-N1300N | Pass | Pending |
| NS13 - Economic Calculations | 2/6/2017 7:00:00 PM | Download | Available 02/06/2017 5pm EST | Available 02/06/2017 5pm EST | Pending |
| NS13 - Lateral Load Systems and Details | 2/13/2017 7:00:00 PM | Download | Available 02/13/2017 5pm EST | Available 02/13/2017 5pm EST | Pending |
| NS13 - Preliminary Design Procedures | 2/27/2017 7:00:00 PM | Download | Available 03/02/2017 5pm EST | Available 03/02/2017 5pm EST | Pending |
| NS13 - Crane Order Design and Frame Analysis | 3/6/2017 7:00:00 PM | Download | Available 03/06/2017 5pm EST | Available 03/06/2017 5pm EST | Pending |
| NS13 - Frame Member and Connection Design | 3/13/2017 7:00:00 PM | Download | Available 03/13/2017 5pm EST | Available 03/13/2017 5pm EST | Pending |
| NS13 - Transfer Crane Girder & Longitudinal Bracing Design | 3/27/2017 7:00:00 PM | Download | Available 03/29/2017 5pm EST | Available 03/29/2017 5pm EST | Pending |
| NS13 - Building Envelope and Bracing Design | 4/3/2017 7:00:00 PM | Download | Available 04/05/2017 5pm EST | Available 04/05/2017 5pm EST | Pending |



8-Session Registrants

Night School Resources

- Weekly “quiz and recording” email.
- Weekly updates of the master quiz and attendance record, found at www.aisc.org/nightschool28. Scroll down to Quiz and Attendance records.
 - Updated on Friday mornings.



8-Session Registrants

Night School Resources

- Webinar connection information
 - Reminder email sent out Monday mornings
- Links to handouts also found here

